

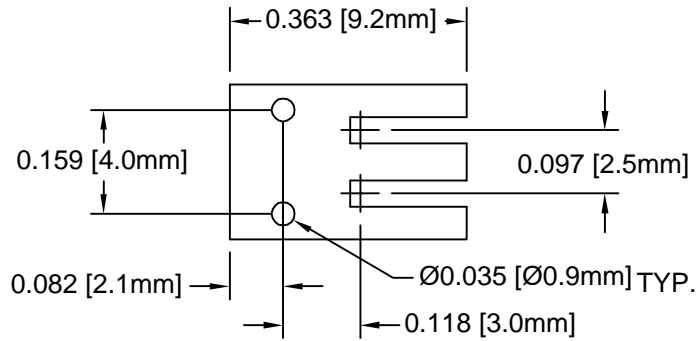

REV.	DESCRIPTION	DATE	APPROVED
A	Engineering Release	02/19/04	M. C.

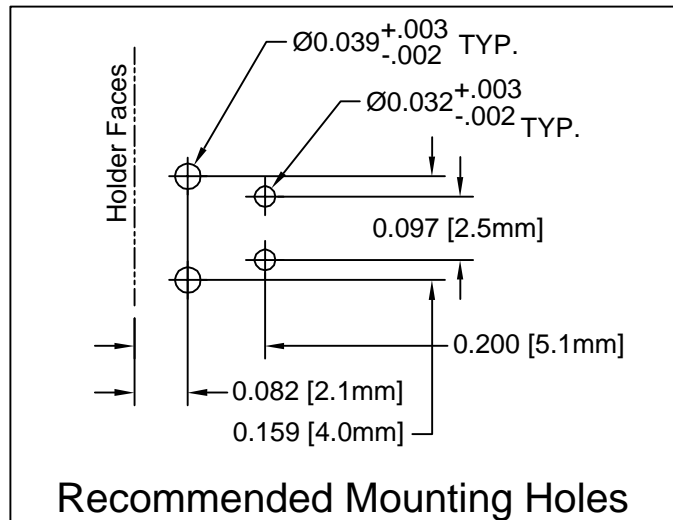
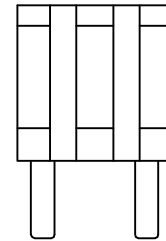
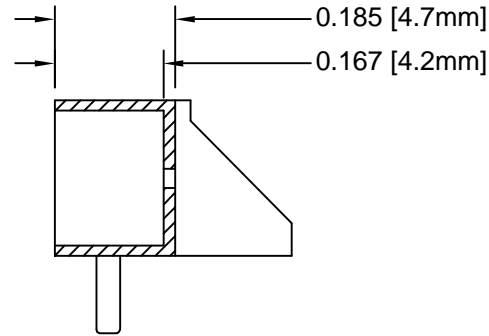
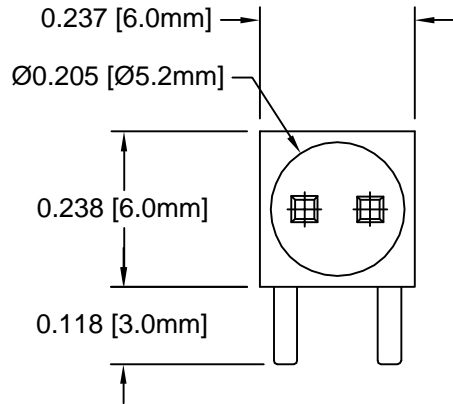
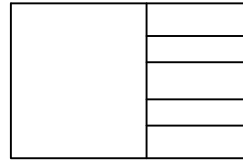

2. MATERIAL: NYLON 6/6, 94V-0, BLACK. BIVAR MATERIAL CODE 22-BK.
RTP POLYAMIDE NYLON 6/6, 0200 FR, BLACK OR MODIFIED PLASTICS MN6/6-SE BK.
1. GENERAL SPECIFICATIONS: BIVAR MOLDED COMPONENT SPECIFICATION BV00-E101.

STANDARD TOLERANCE (UNLESS OTHERWISE SPECIFIED)		 BIVAR [®] 4 THOMAS, IRVINE, CA. 92618 TEL: (949) 951-8808 FAX: (949) 951-3974	
DECIMALS	ANGULAR		
.X ± .1	X° ± 1°		
.XX ± .01			
.XXX ± .005		TITLE: T-1 (3mm) LED HOLDER	
DESIGNED: Shane Irving	DATE: 12/03/98	PART NO: H-178C-LP	REVISION: A
CHECKED: M. Chen	DATE: 02/19/04	CAGE CODE : 32559	SHEET # 1 OF 1
CAD GENERATED DOCUMENT, DO NOT MEASURE DRAWING.			