

XMC1100 CPU Card

For XMC1000 Family

CPU-11A-V1

XMC1100 CPU Card

Board User's Manual

Revision 1.0, 2013-03-08

Microcontroller

Edition 2013-03-08

**Published by
Infineon Technologies AG
81726 Munich, Germany**

**© 2013 Infineon Technologies AG
All Rights Reserved.**

Legal Disclaimer

The information given in this document shall in no event be regarded as a guarantee of conditions or characteristics. With respect to any examples or hints given herein, any typical values stated herein and/or any information regarding the application of the device, Infineon Technologies hereby disclaims any and all warranties and liabilities of any kind, including without limitation, warranties of non-infringement of intellectual property rights of any third party.

Information

For further information on technology, delivery terms and conditions and prices, please contact the nearest Infineon Technologies Office (www.infineon.com).

Warnings

Due to technical requirements, components may contain dangerous substances. For information on the types in question, please contact the nearest Infineon Technologies Office.

Infineon Technologies components may be used in life-support devices or systems only with the express written approval of Infineon Technologies, if a failure of such components can reasonably be expected to cause the failure of that life-support device or system or to affect the safety or effectiveness of that device or system. Life support devices or systems are intended to be implanted in the human body or to support and/or maintain and sustain and/or protect human life. If they fail, it is reasonable to assume that the health of the user or other persons may be endangered.

Revision History

Page or Item	Subjects (major changes since previous revision)
Revision 1.0, 2013-03-08	

Trademarks of Infineon Technologies AG

AURIX™, C166™, CanPAK™, CIPOS™, CIPURSET™, EconoPACK™, CoolMOS™, CoolSET™, CORECONTROL™, CROSSAVE™, DAVE™, DI-POL™, EasyPIM™, EconoBRIDGE™, EconoDUAL™, EconoPIM™, EconoPACK™, EiceDRIVER™, eupec™, FCOS™, HITFET™, HybridPACK™, I²RF™, ISOFACE™, IsoPACK™, MIPAQ™, ModSTACK™, my-d™, NovalithIC™, OptiMOS™, ORIGAT™, POWERCODE™, PRIMARION™, PrimePACK™, PrimeSTACK™, PRO-SIL™, PROFET™, RASIC™, ReverSave™, SatRIC™, SIEGET™, SINDRION™, SIPMOS™, SmartLEWIS™, SOLID FLASH™, TEMPFET™, thinQ!™, TRENCHSTOP™, TriCore™.

Other Trademarks

Advance Design System™ (ADS) of Agilent Technologies, AMBA™, ARM™, MULTI-ICE™, KEIL™, PRIMECELL™, REALVIEW™, THUMB™, μVision™ of ARM Limited, UK. AUTOSAR™ is licensed by AUTOSAR development partnership. Bluetooth™ of Bluetooth SIG Inc. CAT-iq™ of DECT Forum. COLOSSUS™, FirstGPS™ of Trimble Navigation Ltd. EMV™ of EMVCo, LLC (Visa Holdings Inc.). EPCOS™ of Epcos AG. FLEXGO™ of Microsoft Corporation. FlexRay™ is licensed by FlexRay Consortium. HYPERTERMINAL™ of Hilgraeve Incorporated. IEC™ of Commission Electrotechnique Internationale. IrDA™ of Infrared Data Association Corporation. ISO™ of INTERNATIONAL ORGANIZATION FOR STANDARDIZATION. MATLAB™ of MathWorks, Inc. MAXIM™ of Maxim Integrated Products, Inc. MICROTEC™, NUCLEUS™ of Mentor Graphics Corporation. MIPI™ of MIPI Alliance, Inc. MIPS™ of MIPS Technologies, Inc., USA. muRata™ of MURATA MANUFACTURING CO., MICROWAVE OFFICE™ (MWO) of Applied Wave Research Inc., OmniVision™ of OmniVision Technologies, Inc. Openwave™ Openwave Systems Inc. RED HAT™ Red Hat, Inc. RFMD™ RF Micro Devices, Inc. SIRIUS™ of Sirius Satellite Radio Inc. SOLARIS™ of Sun Microsystems, Inc. SPANSION™ of Spansion LLC Ltd. Symbian™ of Symbian Software Limited. TAIYO YUDEN™ of Taiyo Yuden Co. TEAKLITE™ of CEVA, Inc. TEKTRONIX™ of Tektronix Inc. TOKO™ of TOKO KABUSHIKI KAISHA TA. UNIX™ of X/Open Company Limited. VERILOG™, PALLADIUM™ of Cadence Design Systems, Inc. VLYNQ™ of Texas Instruments Incorporated. VXWORKS™, WIND RIVER™ of WIND RIVER SYSTEMS, INC. ZETEX™ of Diodes Zetex Limited.

Last Trademarks Update 2011-11-11

Table of Contents

1	Overview	7
1.1	Key Features	7
1.2	Block Diagram	7
2	Hardware Description	8
2.1	XMC1100 connector for ARDUINO™	8
2.1.1	Digital IO connector	8
2.1.2	Analog input	10
2.1.3	Power connector, POWER	10
2.1.4	ICSP (In-Circuit Serial Programming) Header	11
2.2	LEDs	11
2.3	Other connectors	12
3	Production Data	14
3.1	Schematics	14
3.2	Layout and Geometry	17
3.3	Bill of Material	17

List of Figures

Figure 1	Block Diagram of XMC1100 CPU Card for Arduino™	7
Figure 2	XMC1100 CPU Card for Arduino™	8
Figure 3	Digital IO connectors IOH, IOL	9
Figure 4	Analog input AD connector	10
Figure 5	POWER connector	11
Figure 6	ICSP connector	11
Figure 7	LEDs Circuit	12
Figure 8	AD_AUX and AUX connector	12
Figure 9	Schematic 1 of 2 XMC1100 CPU Card for Arduino™	15
Figure 10	Schematic 2 of 2 XMC1100 CPU Card for Arduino™	16
Figure 11	XMC1100 CPU Card for Arduino™ layout and geometry	17

List of Tables

Table 1	Digital IO of connector IOH	9
Table 2	Digital IO of connector IOL	9
Table 3	Pinout of the AD connector	10
Table 4	Pinout of the POWER connector	11
Table 5	Signals of ICSP connector	11
Table 6	LEDs Signal Description	12
Table 7	Signals of connector AD_AUX	13
Table 8	Signals of connector AUX	13
Table 9	XMC1100 CPU Card for Arduino TM	17

Introduction

This document describes the features and hardware details of the XMC1100 CPU Card for Arduino™. This board is mounted with ARM® Cortex™-M0 based XMC1100 Microcontroller from Infineon Technologies AG and part of Infineon's XMC1000 offering of Kits.

1 Overview

The XMC1100 CPU Card for Arduino™ has two rows of pin headers which fully compatible with Arduino™ shield. Hence, user can buy various Arduino shield boards off-the-shelf to test the capabilities of XMC1100 Microcontroller.

1.1 Key Features

The XMC1100 CPU Card for Arduino™ is equipped with the following features

- XMC1100 (ARM® Cortex™-M0 based) Microcontroller, TSSOP38
- Headers compatible with Arduino™ shield
- Detachable SEGGER J-Link debugger and UART virtual COM port, with micro USB connector
- Power supply concept compatible with Arduino™ Uno
- One LED as required from Arduino™ board specification and six additional LEDs

1.2 Block Diagram

Figure 1 shows the block diagram of the XMC1100 CPU Card for Arduino™. There are following blocks:

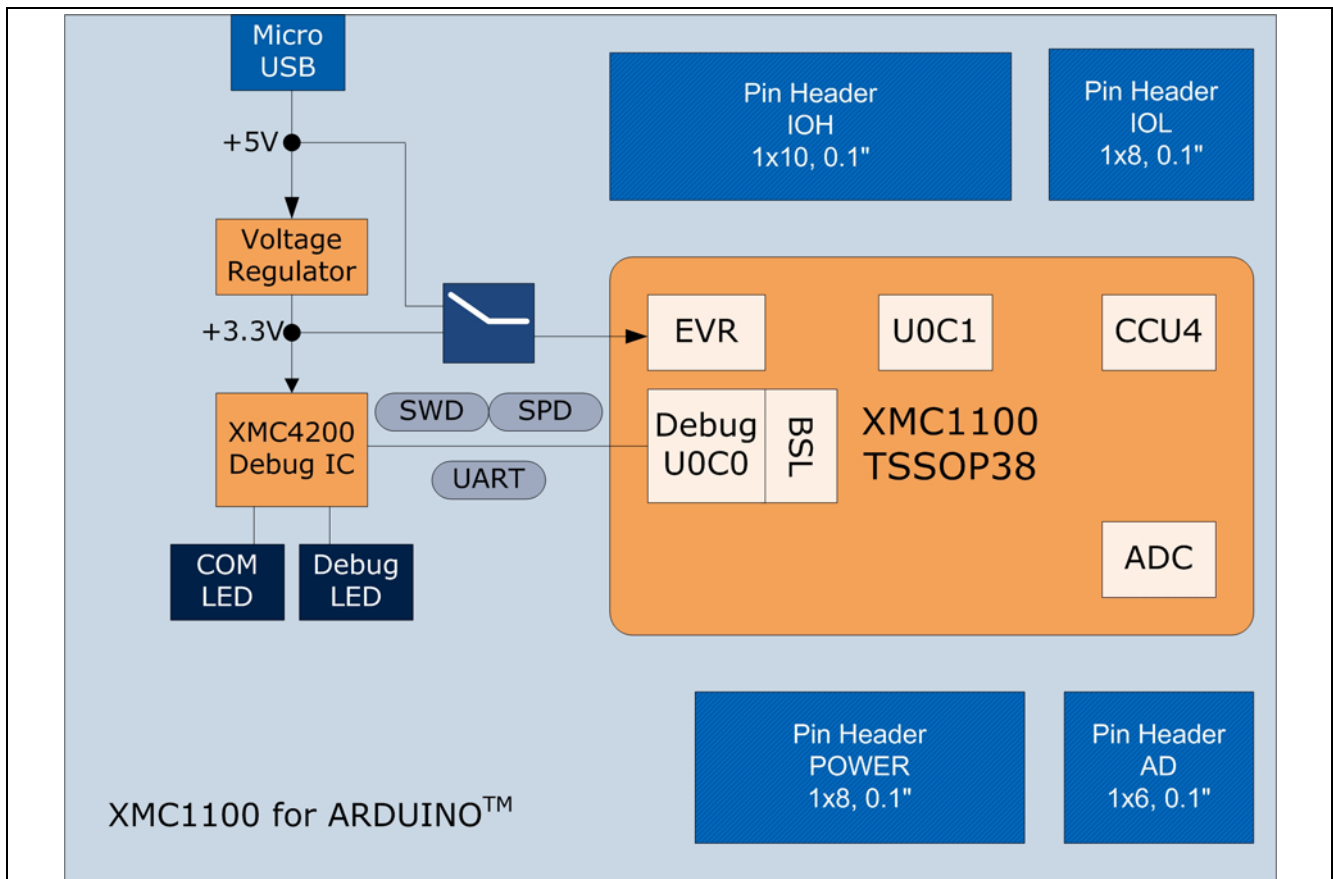

Figure 1 Block Diagram of XMC1100 CPU Card for Arduino™

2 Hardware Description

The following sections give a detailed description of the hardware and how it can be used.

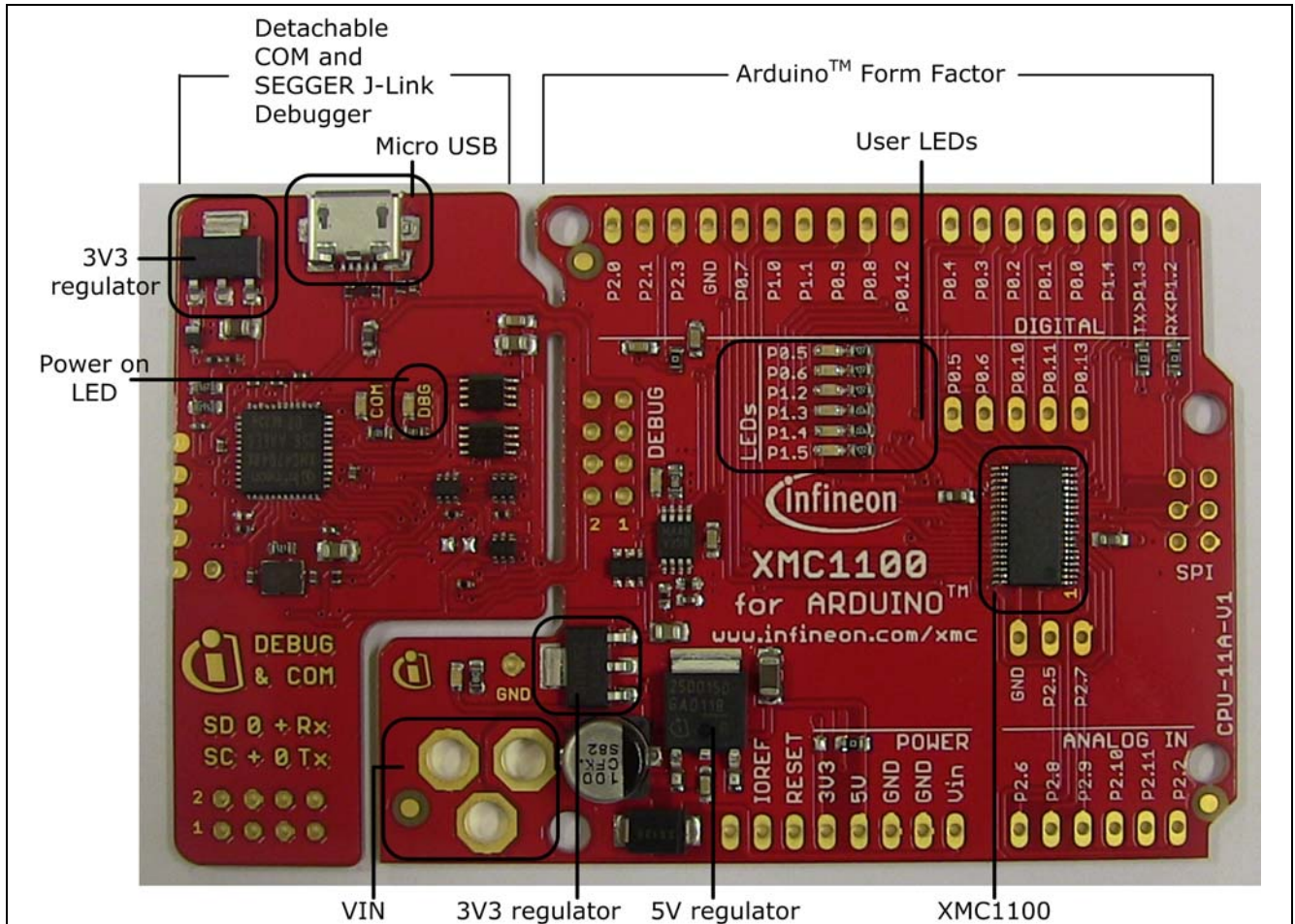

Figure 2 XMC1100 CPU Card for Arduino™

2.1 XMC1100 connector for ARDUINO™

2.1.1 Digital IO connector

XMC1100 CPU Card for Arduino™ have 10 pin connector mounting holes and 8 pin connector mounting holes at IOH and IOL respectively. Sixteen of those pins are digital input or output pins. The pinouts are listed in Table 1 and Table 2.

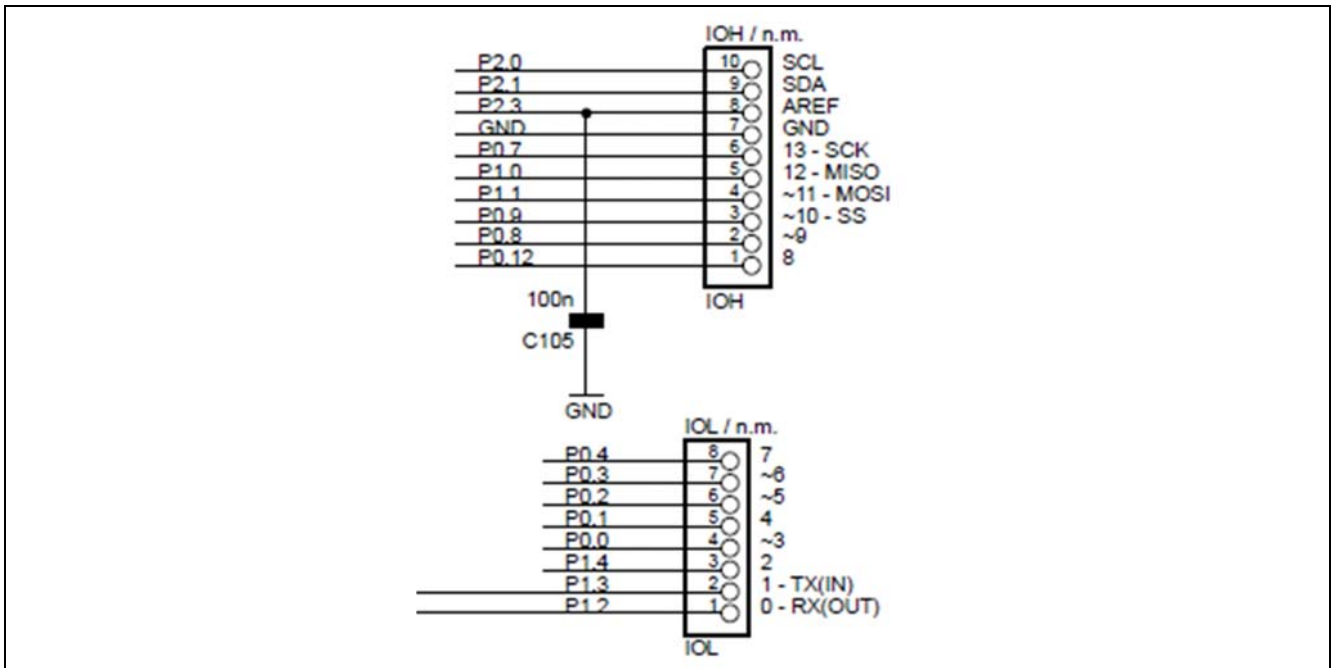

Figure 3 Digital IO connectors IOH, IOL

Table 1 Digital IO of connector IOH

Pin No.	Arduino™ Signal Name	XMC1100 Signal Name	Description
10	SCL	P2.0	I ² C Clock
9	SDA	P2.1	I ² C Data / Address
8	AREF	P2.3	Analog reference voltage
7	GND	GND	Ground
6	13 - SCK	P0.7	SPI-SCK / LED output
5	12 - MISO	P1.0	SPI-MISO
4	~11 - MOSI	P1.1	SPI-MOSI / PWM output
3	~10 - SS	P0.9	SPI-SS / PWM output
2	~9 -	P0.8	PWM output
1	8	P0.12	GPIO

Table 2 Digital IO of connector IOL

Pin No.	Arduino™ Signal Name	XMC1100 Signal Name	Description
8	7	P0.4	GPIO
7	~6	P0.3	PWM output
6	~5	P0.2	PWM output
5	4	P0.1	GPIO
4	~3	P0.0	External interrupt / PWM output
3	2	P1.4	External interrupt
2	1 - TX(IN)	P1.3	Device received UART signal
1	0 - RX(OUT)	P1.2	Device transmit UART signal

2.1.2 Analog input

XMC1100 CPU Card for Arduino™ has six analog inputs at connector AD.

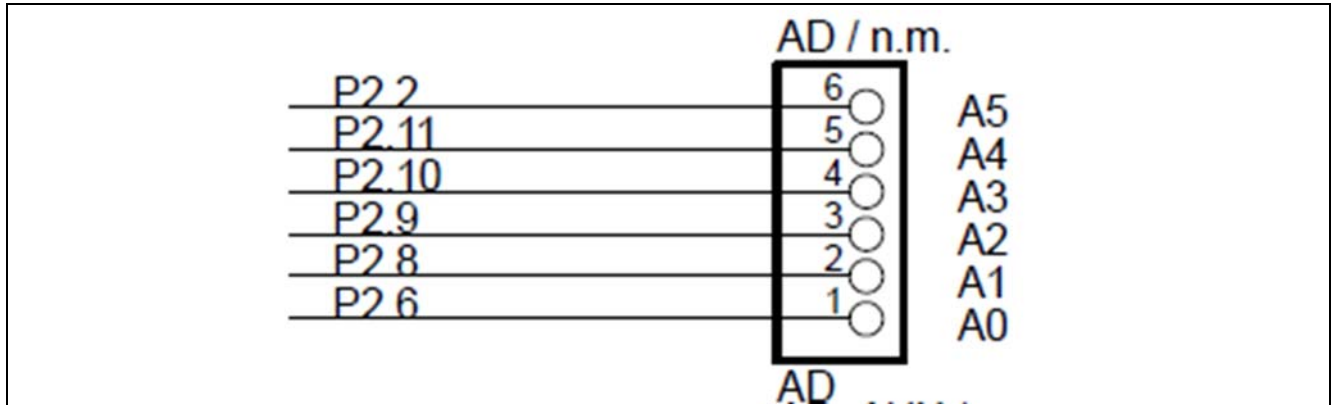

Figure 4 Analog input AD connector

Table 3 Pinout of the AD connector

Pin No.	Arduino™ Signal Name	XMC1100 Signal Name	Description
1	A0	P2.6	ADC Input
2	A1	P2.8	ADC Input
3	A2	P2.9	ADC Input
4	A3	P2.10	ADC Input
5	A4	P2.11	ADC Input
6	A5	P2.2	ADC Input

2.1.3 Power connector, POWER

XMC1100 CPU Card for Arduino™ can be powered from the micro USB connector or with an external power supply via the DC power jack. However, the DC power jack is not mounted.

The XMC1100 device can operate by power supply of 1.8V till 5.5Vdc. On this board, 5Vdc is used to power the XMC1100 device. However, if user wants to power the XMC1100 device with 3.3Vdc, then, please remove R102 and solder 0 ohm resistor R101.

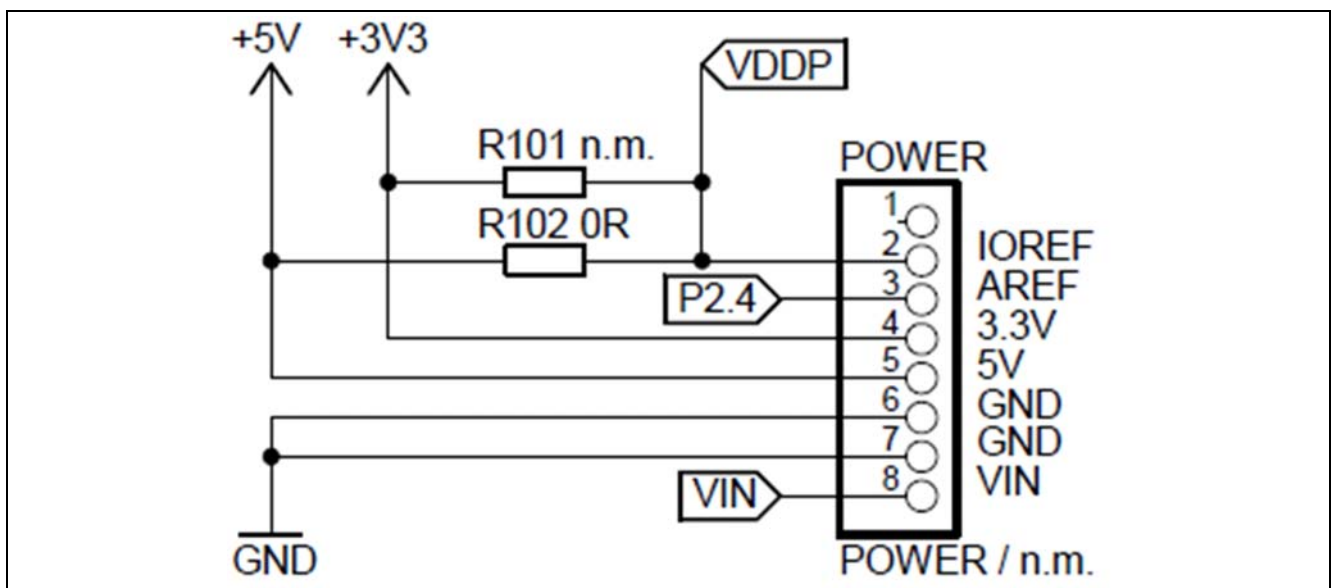

Figure 5 POWER connector

Table 4 Pinout of the POWER connector

Pin No.	Arduino™ Signal Name	XMC1100 Signal Name	Description
1	-	-	-
2	IOREF	VDDP	VDDP connect to 5V via R102
3	AREF	P2.4	ADC input to sense Analog reference voltage
4	3.3V	+3V3	3.3V is generated by a 3.3V regulator IC101 from +5V
5	5V	+5V	+5V is generated by the 5V regulator IC102 from VIN input. If VIN is not powered, +5V is supply by micro-USB connector.
6	GND	GND	Ground
7	GND	GND	Ground
8	VIN	VIN	DC jack (not mounted), 7-12V

2.1.4 ICSP (In-Circuit Serial Programming) Header

The SPI connector (not mounted) is used to program the XMC1100 microcontroller via the SPI interface.

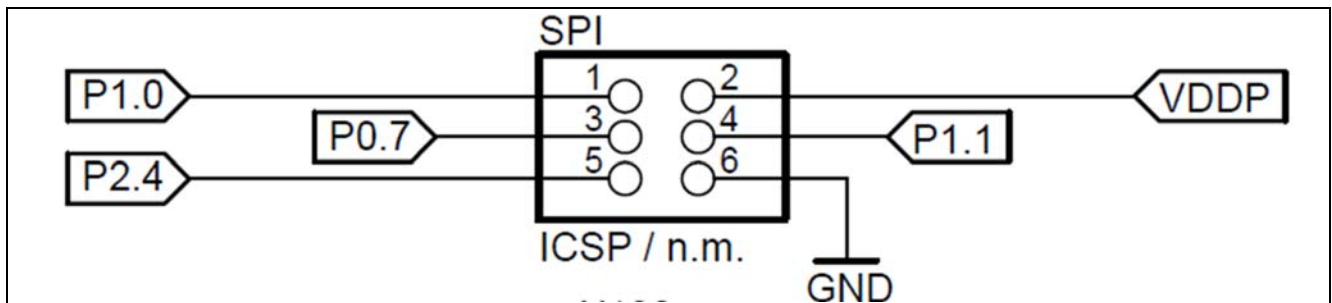

Figure 6 ICSP connector

Table 5 Signals of ICSP connector

Pin No.	Arduino™ Signal Name	XMC1100 Signal Name	Description
1	MISO	P1.0	Data transmit
2	+5V	VDDP	5Vdc
3	SCK	P0.7	Clock input
4	MOSI	P1.1	Data received
5	SS	P2.4	Chip select
6	GND	GND	ground

2.2 LEDs

Arduino™ pinout signal '13-SCK' is connected to yellow LED102 via a buffer. Furthermore, six surface mount LEDs are available for user signaling. Table 6 shows the LEDs driving signals.

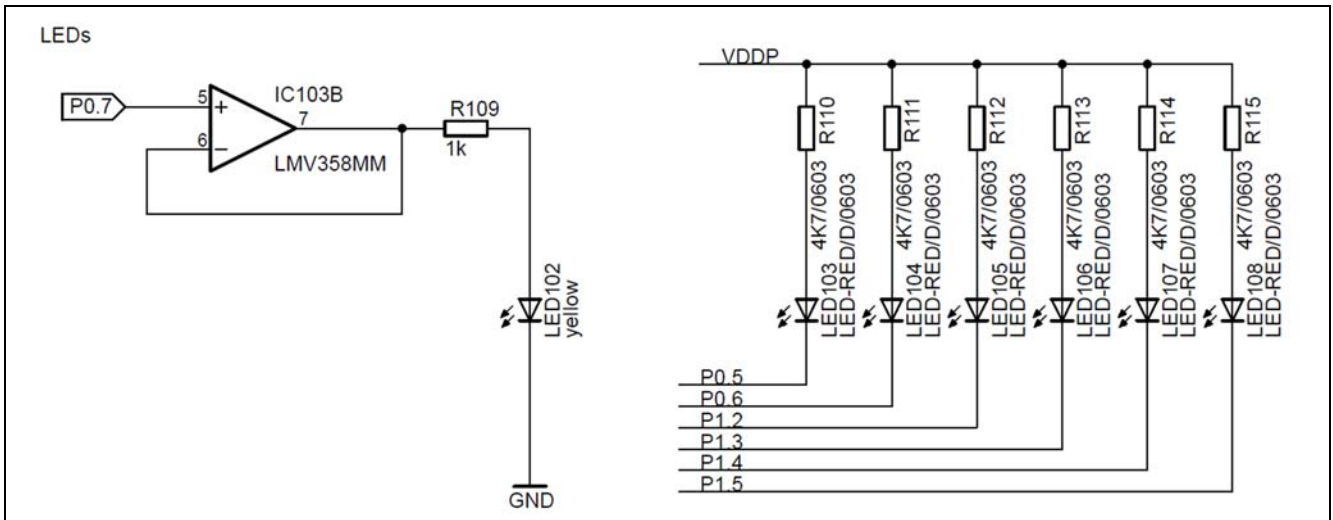

Figure 7 LEDs Circuit

Table 6 LEDs Signal Description

LED Designation	Signal Name	Description
LED102	P0.7	Output 'High' to on LED
LED103	P0.5	Output 'Low' to on LED
LED104	P0.6	Output 'Low' to on LED
LED105	P1.2	Output 'Low' to on LED
LED106	P1.3	Output 'Low' to on LED
LED107	P1.4	Output 'Low' to on LED
LED108	P1.5	Output 'Low' to on LED

2.3 Other connectors

XMC1100 microcontroller has more pins than is required Arduino™ board's pinouts, those extra pins are group into connector AD_AUX (not mount) and AUX (not mount).

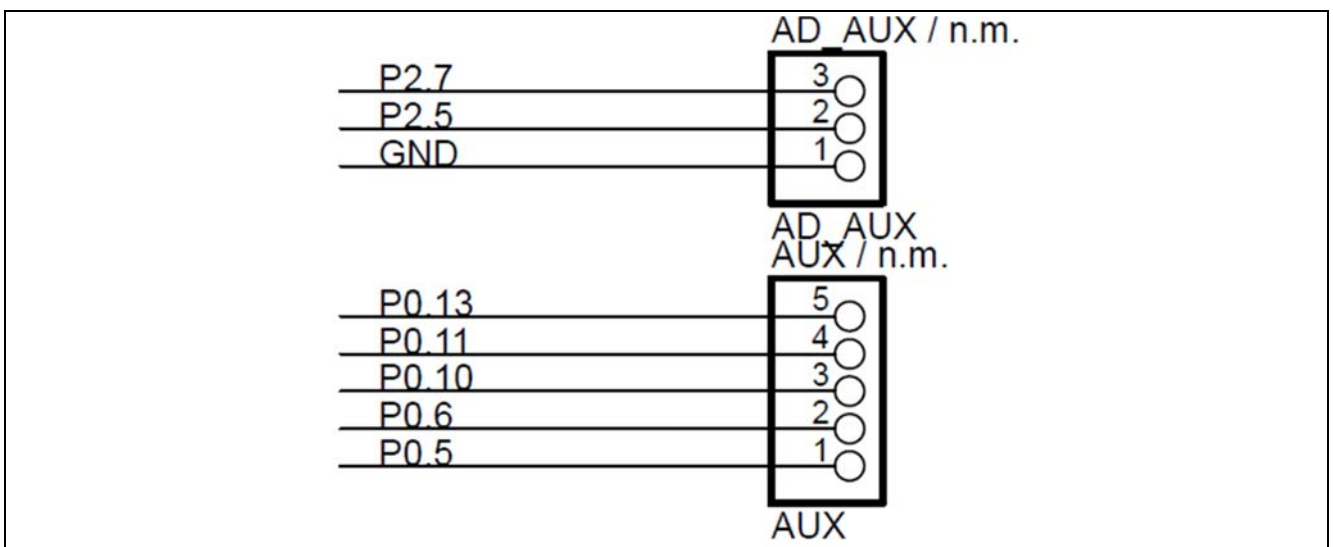

Figure 8 AD_AUX and AUX connector

Table 7 Signals of connector AD_AUX

Pin No.	Signal Name	Description
1	P2.7	ADC input
2	P2.5	ADC input
3	GND	ADC input

Table 8 Signals of connector AUX

Pin No.	Signal Name	Description
1	P0.5	GPIO
2	P0.6	GPIO
3	P0.10	GPIO
4	P0.11	GPIO
5	P0.13	GPIO

3 Production Data

3.1 Schematics

This chapter contains the schematics for the XMC1100 CPU Card for Arduino™:

- Figure 9: CPU, Pin Headers, LED, Power Supply
- Figure 10: On-board Debugger, Power

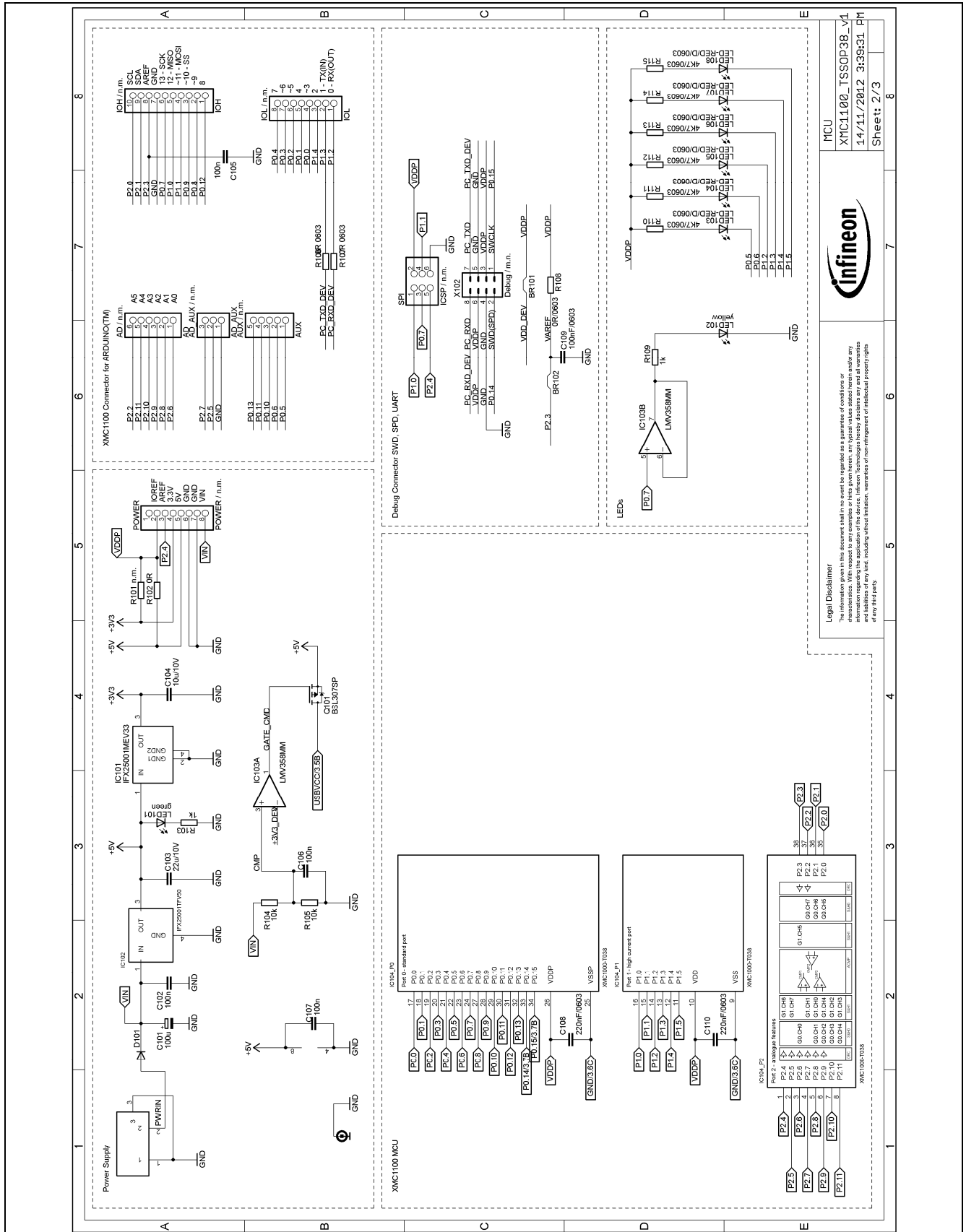

Figure 9 Schematic 1 of 2 XMC1100 CPU Card for Arduino™

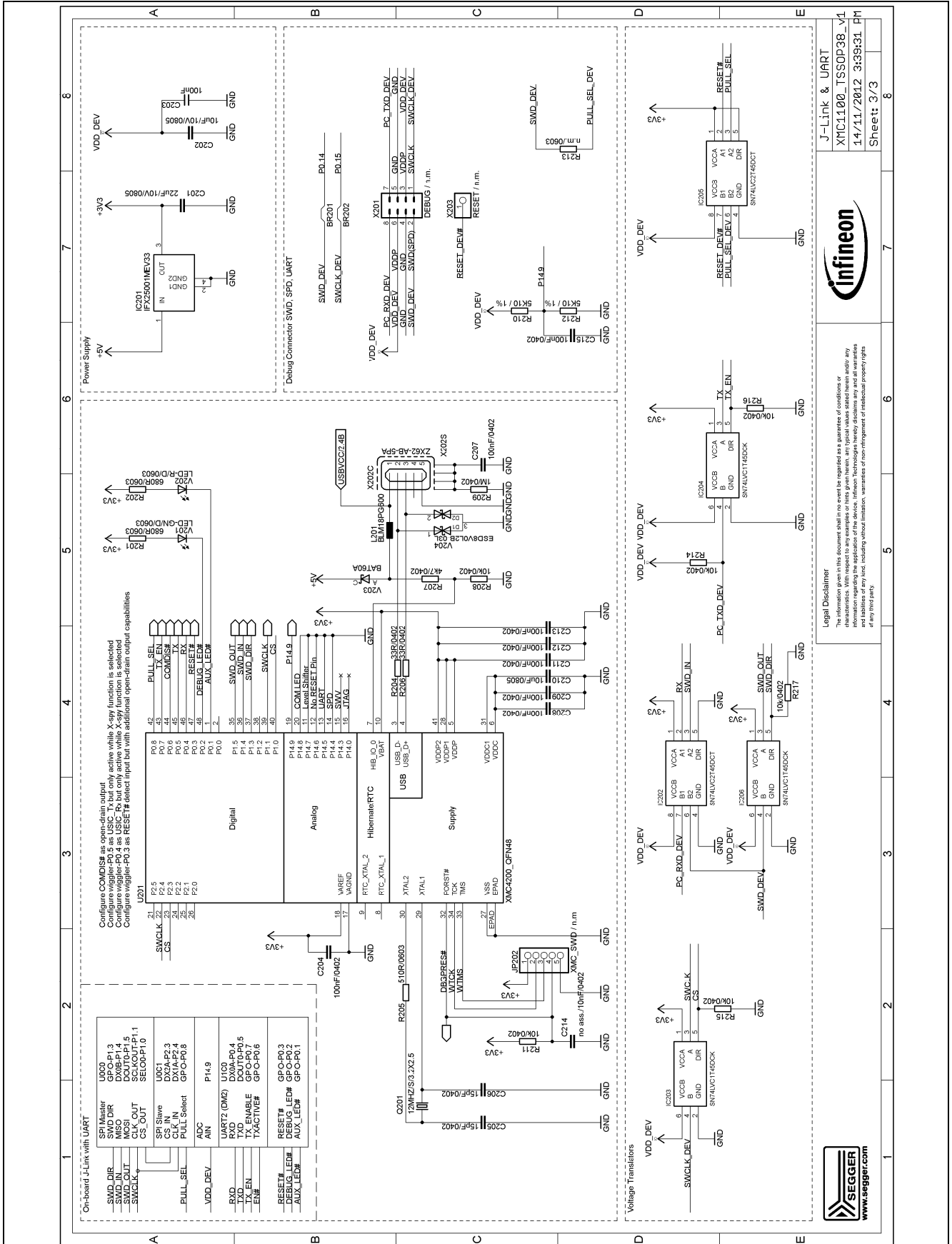

Figure 10 Schematic 2 of 2 XMC1100 CPU Card for Arduino™

3.2 Layout and Geometry

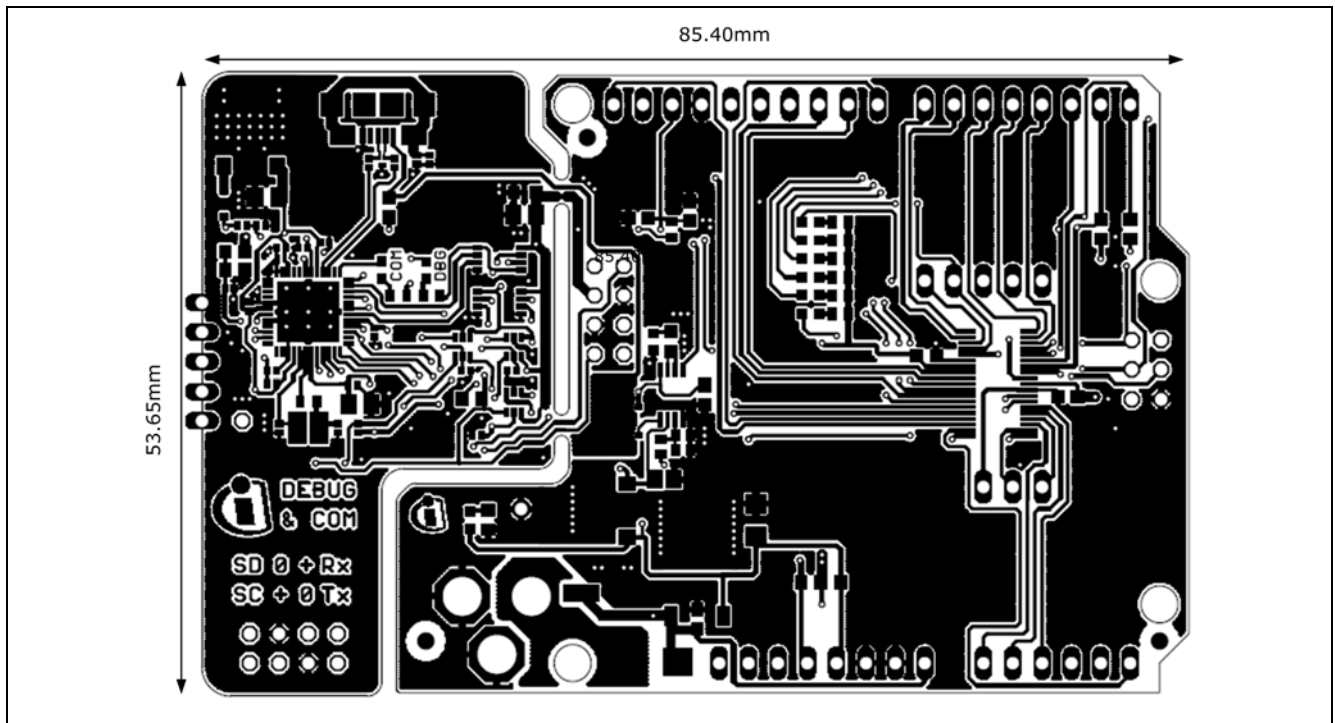

Figure 11 XMC1100 CPU Card for Arduino™ layout and geometry

3.3 Bill of Material

Table 9 XMC1100 CPU Card for Arduino™

No.	Qty	Value	Device	Reference Designator
1	1	100uF/16V/10%/SMC_D	Capacitor	C101
2	1	100n/16/10%/0603	Capacitor	C102
3	1	22u/10V/10%/1206	Capacitor	C103
4	1	10u/10V/10%/1206	Capacitor	C104
5	1	100n10V/10%/0603	Capacitor	C105
6	1	100n/10V/10%/0402	Capacitor	C106
7	1	100n/10V/10%/0603	Capacitor	C107
8	1	220nF/10V/10%/0603	Capacitor	C108
9	1	100nF/10V/10%/0603	Capacitor	C109
10	1	220nF/10V/10%/0603	Capacitor	C110
11	1	22uF/10V/10%/0805	Capacitor	C201
12	1	10uF/10V/10%/0805	Capacitor	C202
13	1	100nF/10V/10%/0603	Capacitor	C203
14	1	100nF/10V/10%/0402	Capacitor	C204
15	1	15pF/10V/10%/0402	Capacitor	C205
16	1	15pF/10V/10%/0402	Capacitor	C206
17	1	100nF/10V/10%/0402	Capacitor	C207
18	1	100nF/10V/10%/0402	Capacitor	C208

No.	Qty	Value	Device	Reference Designator
19	1	100nF/10V/10%/0402	Capacitor	C209
20	1	10uF/10V/10%/0805	Capacitor	C210
21	1	100nF/10V/10%/0402	Capacitor	C211
22	1	100nF/10V/10%/0402	Capacitor	C212
23	1	100nF/10V/10%/0402	Capacitor	C213
24	1	100nF/10V/10%/0402	Capacitor	C215
25	1	SS13B (Multicomp)	Diode	L101
26	1	LMV358MM	Op-Amp	IC103
27	1	SN74LVC2T45DCT	Resistor	IC202
28	1	SN74LVC1T45DCK	Resistor	IC203
29	1	SN74LVC1T45DCK	Resistor	IC204
30	1	SN74LVC2T45DCT	Resistor	IC205
31	1	SN74LVC1T45DCK	Resistor	IC206
32	1	BLM18PG600	Ferrite Bead	L201
33	1	Green LED/0603	ChipLED	LED101
34	1	Yellow LED/0603	ChipLED	LED102
35	1	LED-RED/D/0603	Red ChipLED	LED103
36	1	LED-RED/D/0603	R Red ChipLED	LED104
37	1	LED-RED/D/0603	Red ChipLED	LED105
38	1	LED-RED/D/0603	Red ChipLED	LED106
39	1	LED-RED/D/0603	Red ChipLED	LED107
40	1	LED-RED/D/0603	Red ChipLED	LED108
41	1	12MHZ/S/3.2X2.5	Quarz	Q201
42	1	0R/0603	Resistor	R102
43	1	1k/0603	Resistor	R103
44	1	10k/0402	Resistor	R104
45	1	10k0402	Resistor	R105
46	1	0R/0603	Resistor	R106
47	1	0R/0603	Resistor	R107
48	1	0R/0603	Resistor	R108
49	1	1k/0603	Resistor	R109
50	1	4K7/0603	Resistor	R110
51	1	4K7/0603	Resistor	R111
52	1	4K7/0603	Resistor	R112
53	1	4K7/0603	Resistor	R113
54	1	4K7/0603	Resistor	R114
55	1	4K7/0603	Resistor	R115
56	1	680R/0603	Resistor	R201
57	1	680R/0603	Resistor	R202
58	1	33R/0402	Resistor	R204
59	1	510R/0603	Resistor	R205
60	1	33R/0402	Resistor	R206
61	1	4k7/0402	Resistor	R207

No.	Qty	Value	Device	Reference Designator
62	1	10k/0402	Resistor	R208
63	1	1M/0402	Resistor	R209
64	1	5K10/1%/0603	Resistor	R210
65	1	10k/0402	Resistor	R211
66	1	5K10/1%/0603	Resistor	R212
67	1	10k/0402	Resistor	R214
68	1	10k/0402	Resistor	R215
69	1	10k/0402	Resistor	R216
70	1	10k/0402	Resistor	R217
71	1	LED-GN/D/0603	ChipLED	V201
72	1	LED-R/D/0603	ChipLED	V202
73	1	ESD8V0L2B-03L	ChipLED	V204
74	1	ZX62-AB-5PA	Micro-USB	X202
75	1	IFX25001MEV33	3V3 regulator, Infineon	IC101
76	1	IFX25001TFV50	5V regulator, Infineon	IC102
77	1	XMC1000-T038	Microcontroller, Infineon	IC104
78	1	IFX25001MEV33	3V3 regulator, Infineon	IC201
79	1	XMC4200_QFN48	Microcontroller, Infineon	U201
80	1	BAT60A	Diode	V203
81	1	BSL307SP	P Mosfet	Q101
82	1	n.m.	1x6 pin header	AD
83	1	n.m.	1x3 pin header	AD_AUX
84	1	n.m.	1x5 pin header	AUX
85	1	BRIDGE10X10	BRIDGE10	BR101
86	1	BRIDGE10X10	BRIDGE10	BR102
87	1	BRIDGE10X10	BRIDGE10	BR201
88	1	BRIDGE10X10	BRIDGE10	BR202
89	1	n.m.	1x10 pin header	IOH
90	1	n.m.	1x8 pin header	IOL
91	1	n.m.	1x5 pin header	JP202
92	1	POWER	1x8 pin header	POWER
93	1	ICSP	2x3 pin header	SPI
94	1	DC21MMX	DC Power Jack	X101
95	1	MA04-2 Debug	2x4 pin header	X102
96	1	MA04-2 DEBUG	2x4 pin header	X201
97	1	RESET	1x1 pin header	X203
98	1	no ass./10nF/0402	Capacitor	C214
99	1	n.m.	Resistor	R101
100	1	n.m./0603	Resistor	R213

www.infineon.com

Published by Infineon Technologies AG