

ROLLER LEVER MAY BE ADJUSTED FOR AN INFINITE NUMBER OF POSITIONS THRU 360°. ADJUSTMENT IS MADE BY LOOSENING THE LOCK NUT AND THEN THE SCREW AND TURNING GEAR UNTIL LEVER IS IN DESIRED POSITION. SCREW AND LOCK NUT ON SHAFT IS THEN TIGHTENED TO POSITIVELY LOCK LEVER IN POSITION.

LEVER ADJUSTMENT DETAIL  
SCALE 2:1

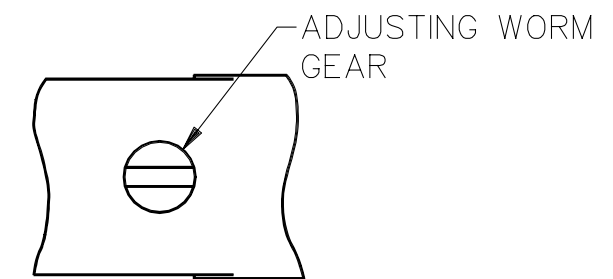
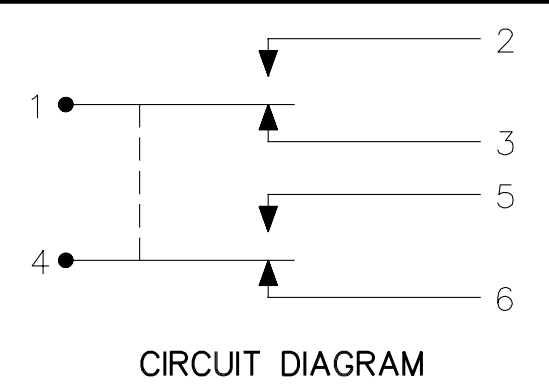

VIEW A-A  
SCALE 2:1

NOTES

- 1 - CORROSION RESISTANT STEEL ENCLOSURE
- 2 - SWITCH SEALED PER MIL-S-8805, SYMBOL 4
- 3 CORROSION RESISTANT STEEL SHAFT, BUSHING AND PINS
- 4 DO NOT APPLY MORE THAN 20-25 INCH-POUNDS OF TORQUE WHEN TIGHTENING LOCKING NUT
- 5 CIRCUIT DIAGRAM, CATALOG LISTING AND MILITARY STANDARD NO. MS 21320-4 ARE SHOWN ON NAMEPLATE
- 6 HARDWARE MAY BE PACKAGED UNASSEMBLED PER MIL-S-8805
- 7 .050 WIDE X .050 DEEP SLOT
- 8 Ø.037 HOLE FOR WIRE LOCKING
- 9 6X NO 18 LEAD WIRE IN ACCORDANCE WITH SPEC MIL-W-22759/7 PERMANENTLY MARKED AT 3" INTERVALS OR LESS WITH SWITCH CIRCUIT IDENTIFICATION NUMBER FOLLOWED BY WIRE GAUGE NO (1-18, 2-18 ETC)

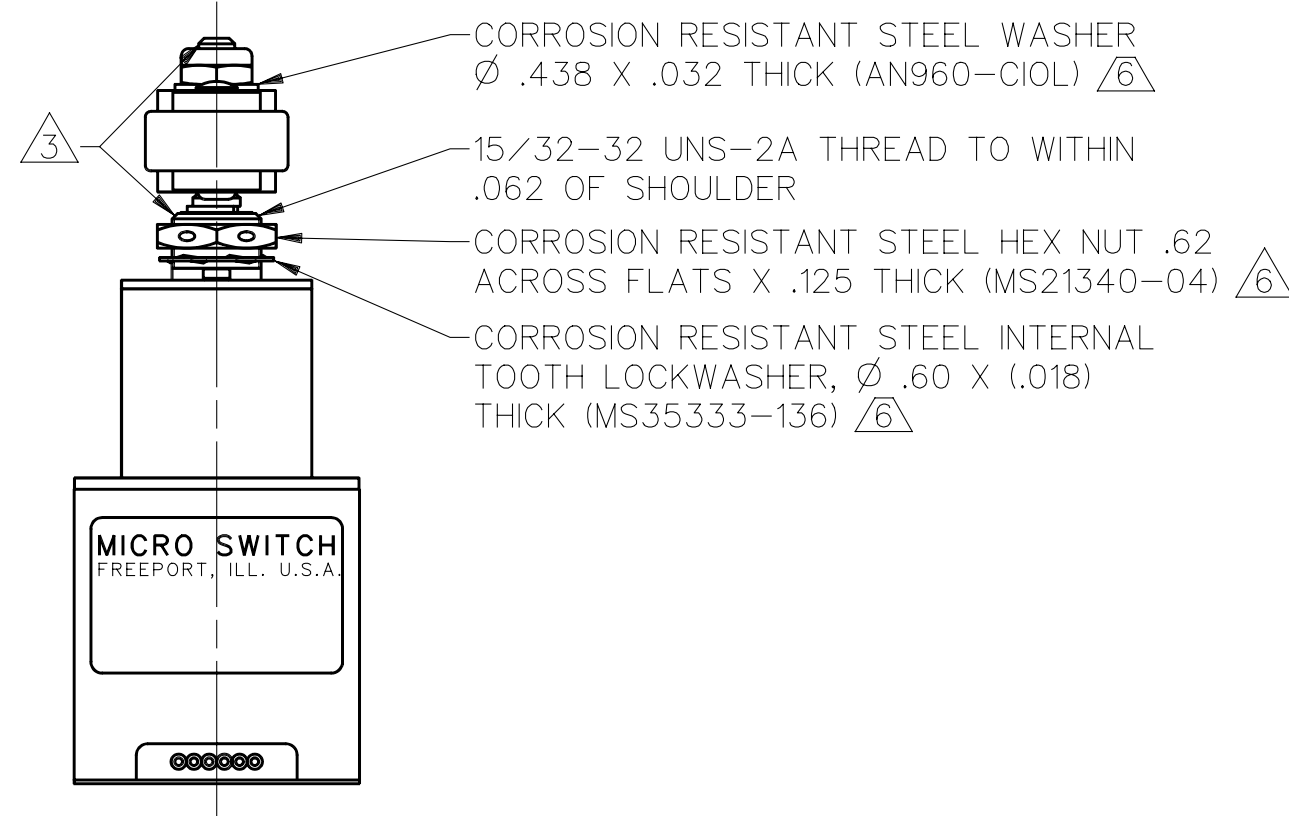
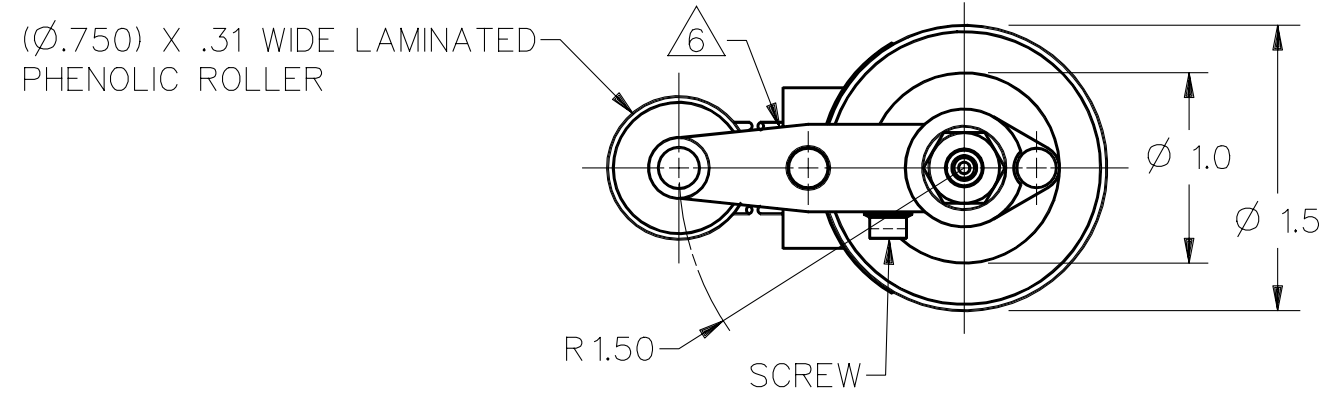

- CORROSION RESISTANT STEEL WASHER Ø .438 X .032 THICK (AN960-CIOL) 6
- 15/32-32 UNS-2A THREAD TO WITHIN .062 OF SHOULDER
- CORROSION RESISTANT STEEL HEX NUT .62 ACROSS FLATS X .125 THICK (MS21340-04) 6
- CORROSION RESISTANT STEEL INTERNAL TOOTH LOCKWASHER, Ø .60 X (.018) THICK (MS35333-136) 6

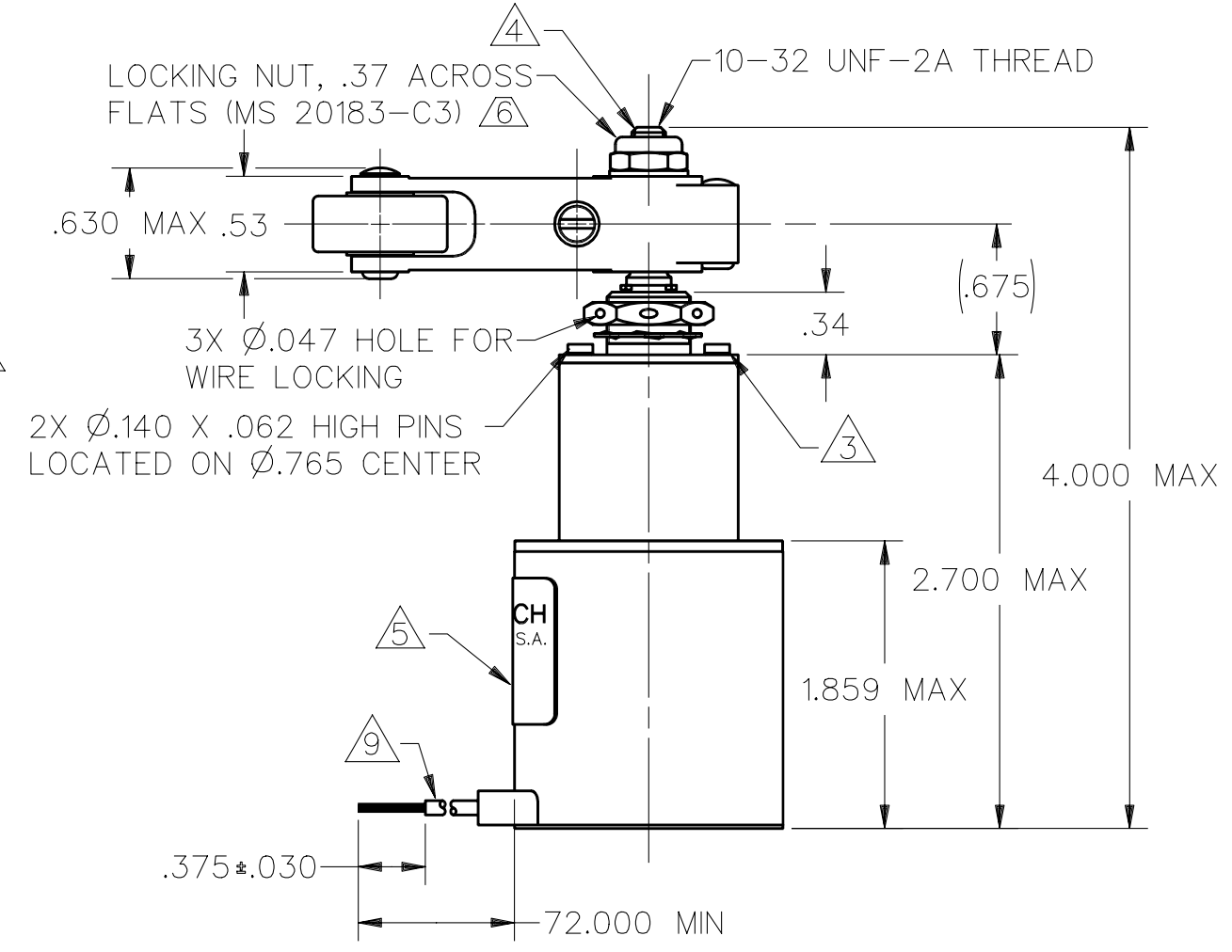

DDM/CAD DRAWN  
 GRT 17 DEC 93 CHECK  
 ISSUE 30  
 DRAWING NUMBER 32EN1-6  
 REPLACES SR5372  
 RELEASE NO. SR5372  
 REVISIONS  
 A CO 76965 G.R. 7 DEC 93  
 B CO 78255 MAM 31 AUG 94  
 C CO83019 J.A.K. 3 OCT 96

CHARACTERISTICS		ELECTRICAL DATA	
OPERATING TORQUE	12-25 IN LB	CONTACT ARRANGEMENT (SEE CIRCUIT DIAGRAM)	
RELEASE TORQUE	4 IN LB MIN	28 VDC	
PRETRAVEL	SEE DETAIL	LOAD	SEA LEVEL
DIFFERENTIAL TRAVEL		RES	50,000 FT
OVERTRAVEL		IND	10
FREE POSITION		MOTOR	6
FULL OVERTRAVEL TORQUE	40 IN-LB MAX		3

MASTER REDUCED  
ANSI Y14.5M-1982 APPLIES

THIS DRAWING COVERS A PROPRIETARY ITEM AND IS THE PROPERTY OF MICRO SWITCH, A DIVISION OF HONEYWELL. THIS DRAWING IS NOT TO BE COPIED OR USED WITHOUT THE APPROVAL OF MICRO SWITCH.

**MICRO SWITCH**  
a Honeywell Division

SWITCH-ENCLOSED

CATALOG LISTING  
**32EN1-6**  
MILITARY STD PART NUMBER  
MS21320-4

THIRD ANGLE PROJECTION

SCALE FULL

DO NOT SCALE PRINT

UNLESS OTHERWISE SPECIFIED TOLERANCES ARE

ONE PLACE	(.0)	±.030
TWO PLACES	(.00)	±.015
THREE PLACES	(.000)	±.005
ANGLES		±

WEIGHT 15.5 OZ