

## Bluetooth low energy board based on the BlueNRG-MS network processor

Data brief

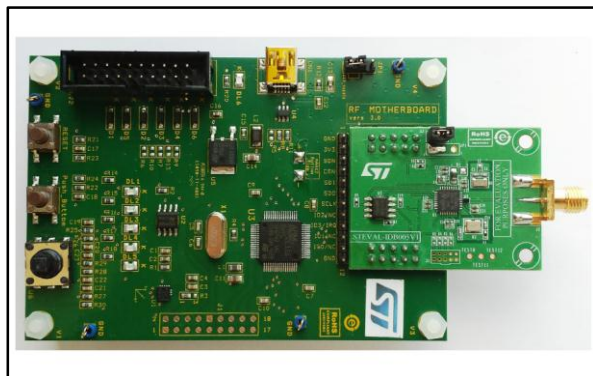

### Description

The STEVAL-IDB005V1 is an evaluation platform based on BlueNRG-MS, a low power Bluetooth® Smart IC, compliant with the Bluetooth® 4.1 specifications and supporting both master and slave roles. The STEVAL-IDB005V1 is composed of an RF daughterboard and a microcontroller motherboard. The RF daughterboard features the BlueNRG-MS device, an SMA connector for an antenna or measuring instruments and an SPI connector for an external microcontroller. The motherboard is based on the STM32L, acting as external microcontroller driving the BlueNRG-MS device. A JTAG connector allows microcontroller firmware development.

### Features

- Bluetooth® SMART board based on the BlueNRG-MS low energy network processor
- STM32L external microcontroller
- Associated BlueNRG-MS development kit, including documentation, firmware for STM32L and GUI
- Maximum transmission power +8 dBm
- Excellent receiver sensitivity (-88 dBm)
- Very low power consumption: 7.3 mA RX and 8.3 mA TX at +0 dBm
- Bluetooth® low energy 4.1 compliant, supports both master and slave roles
- iTunes app available (app name: BlueNRG)
- Google Play app available (app name: BlueNRG)
- JTAG debug connector
- USB Interface
- RoHS compliant

# 1 Schematic diagram

Figure 1: STEVAL-IDB005V1 daughterboard

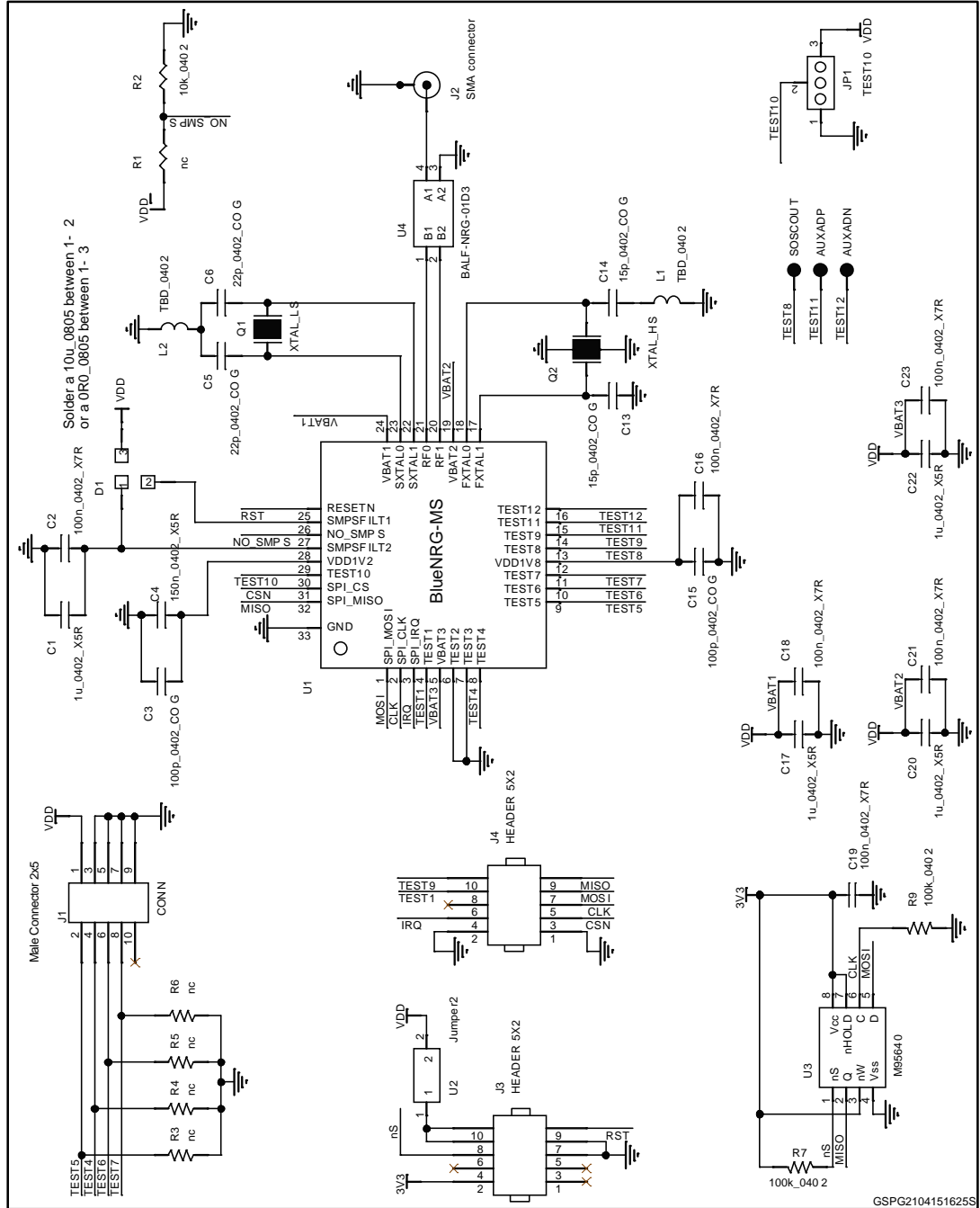

Figure 2: Temperature sensor

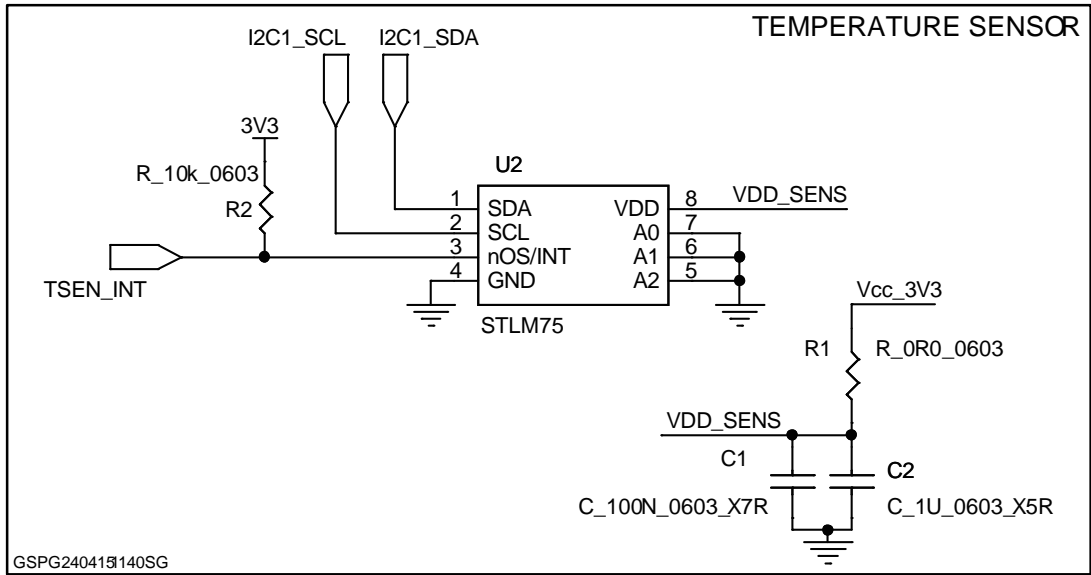

Figure 3: Accelerometer

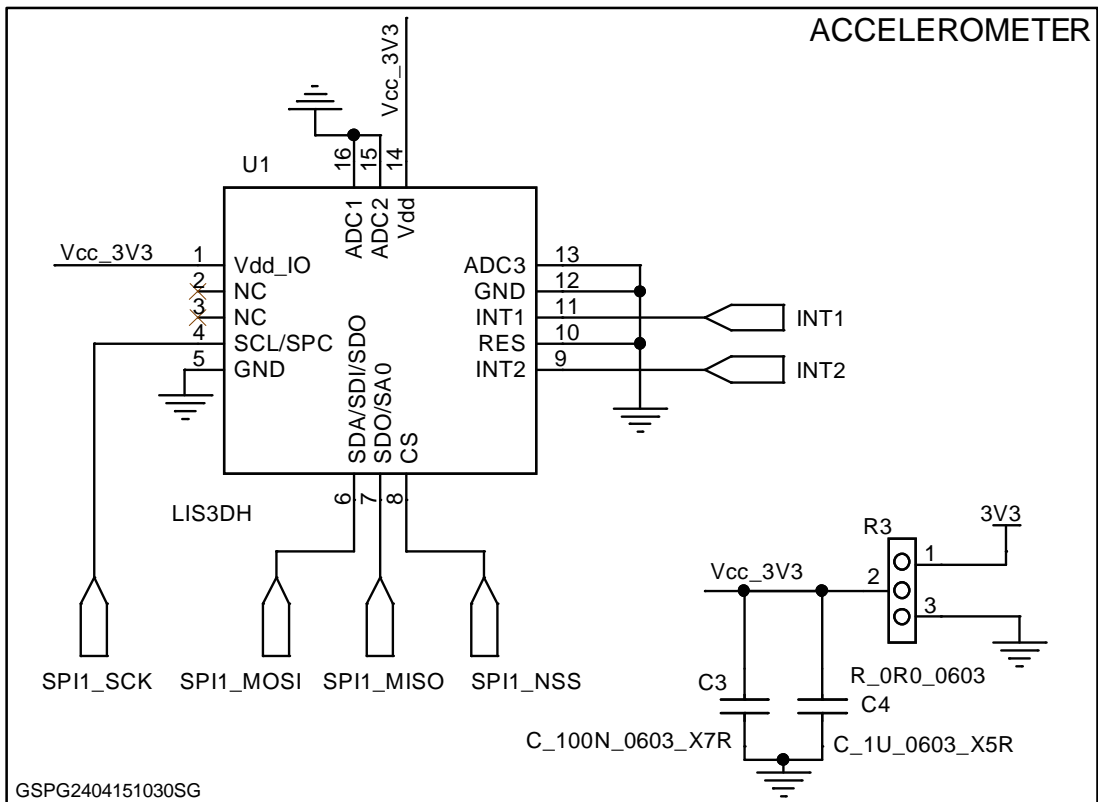

Figure 4: MCU

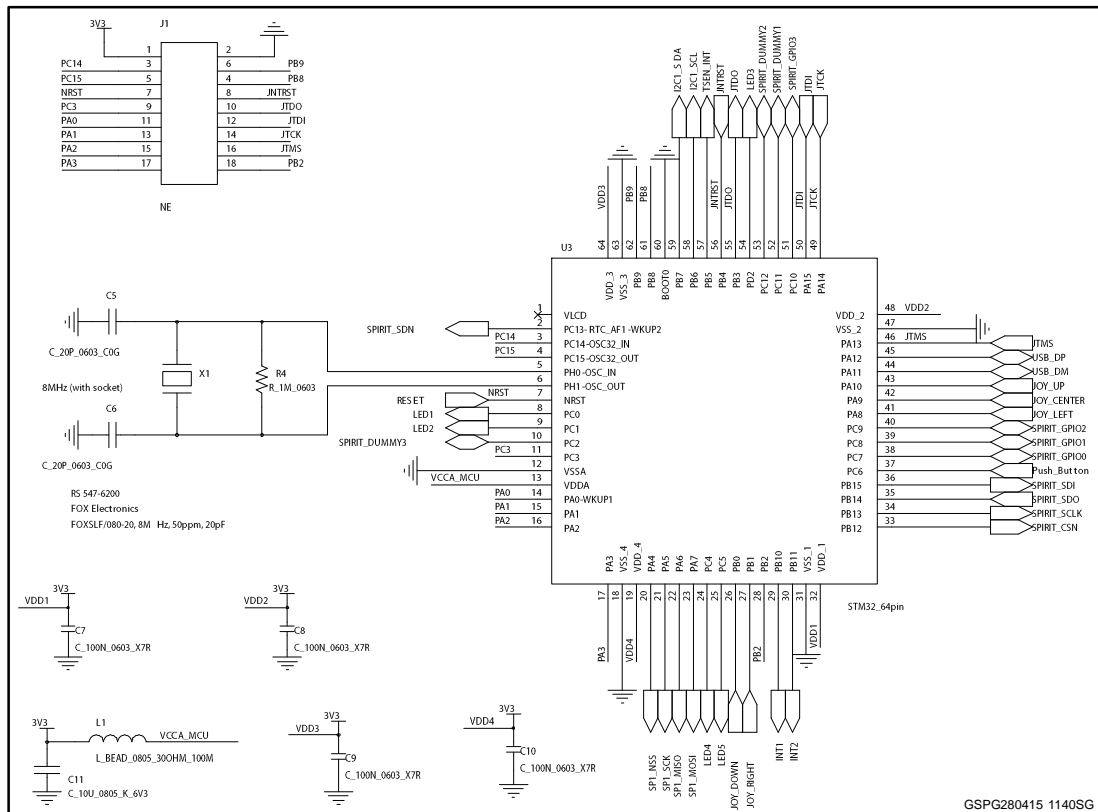

Figure 5: JTAG / SWD

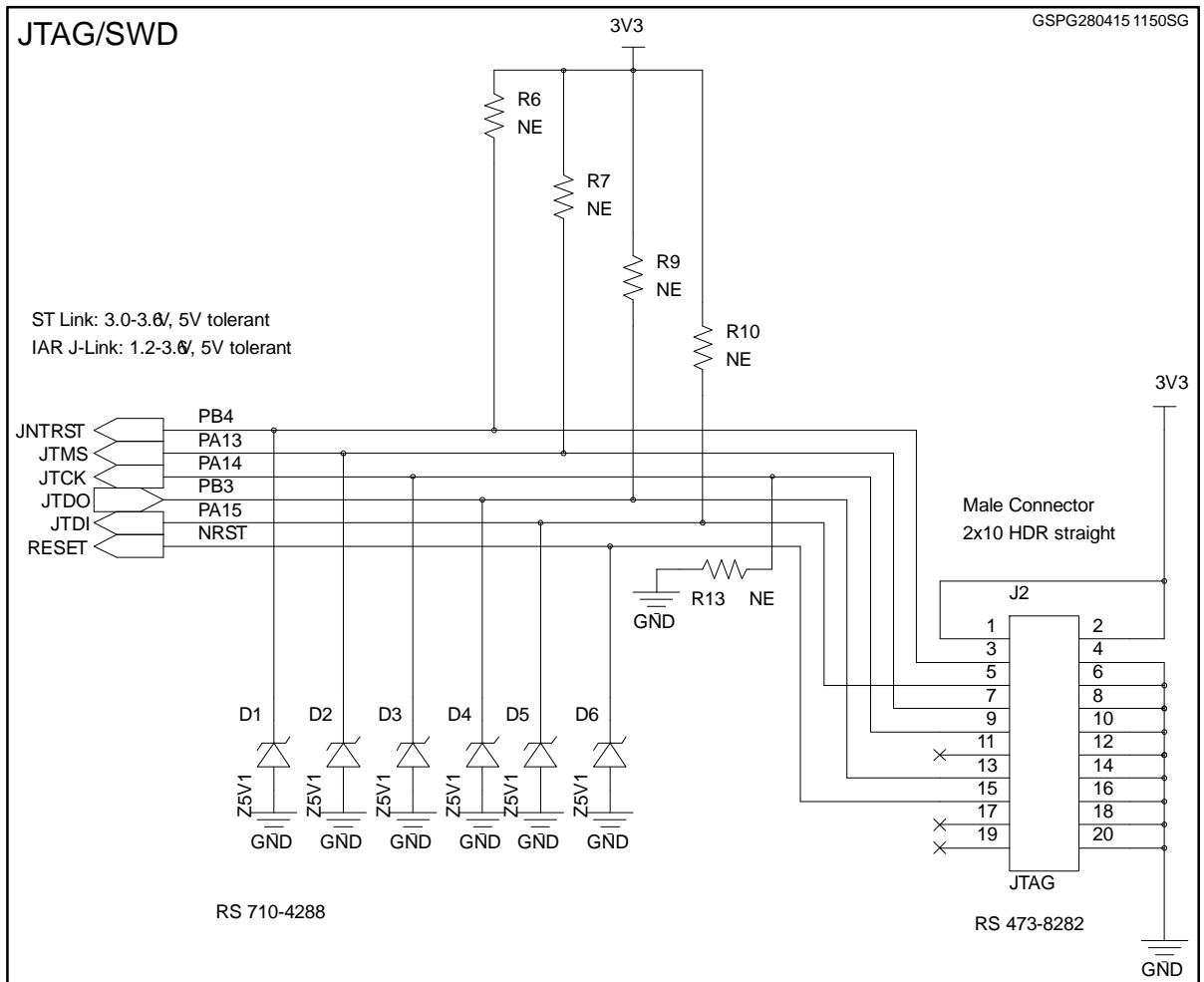

Figure 6: USB

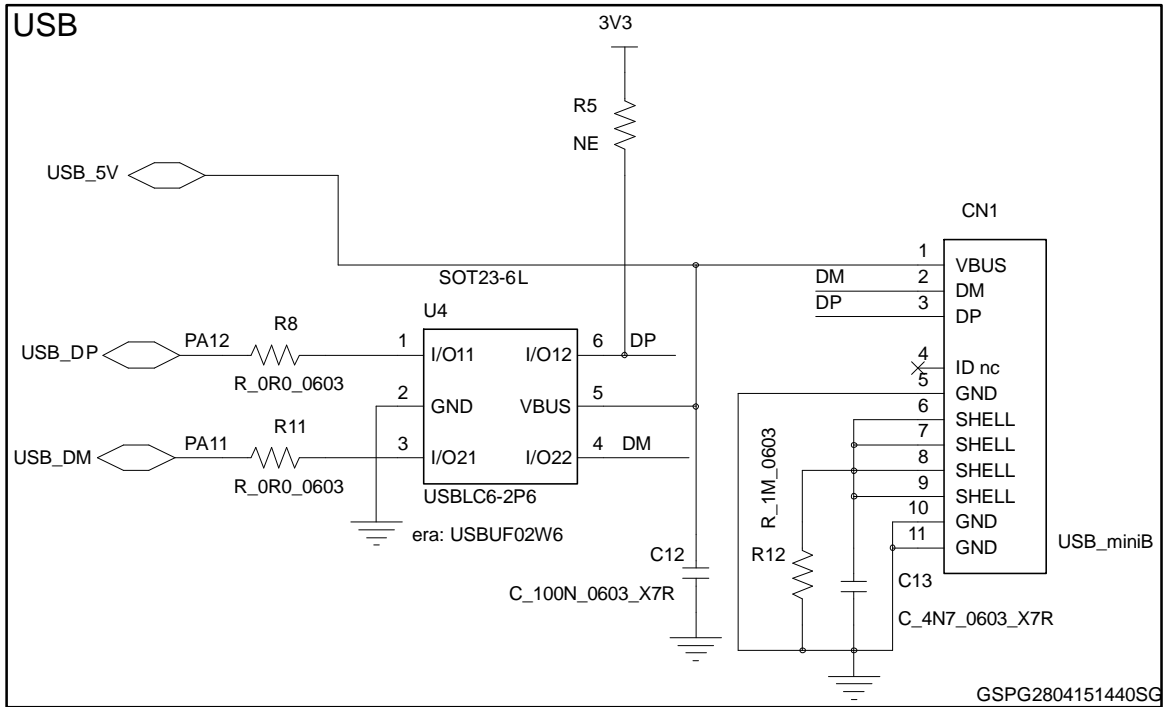

Figure 7: LED

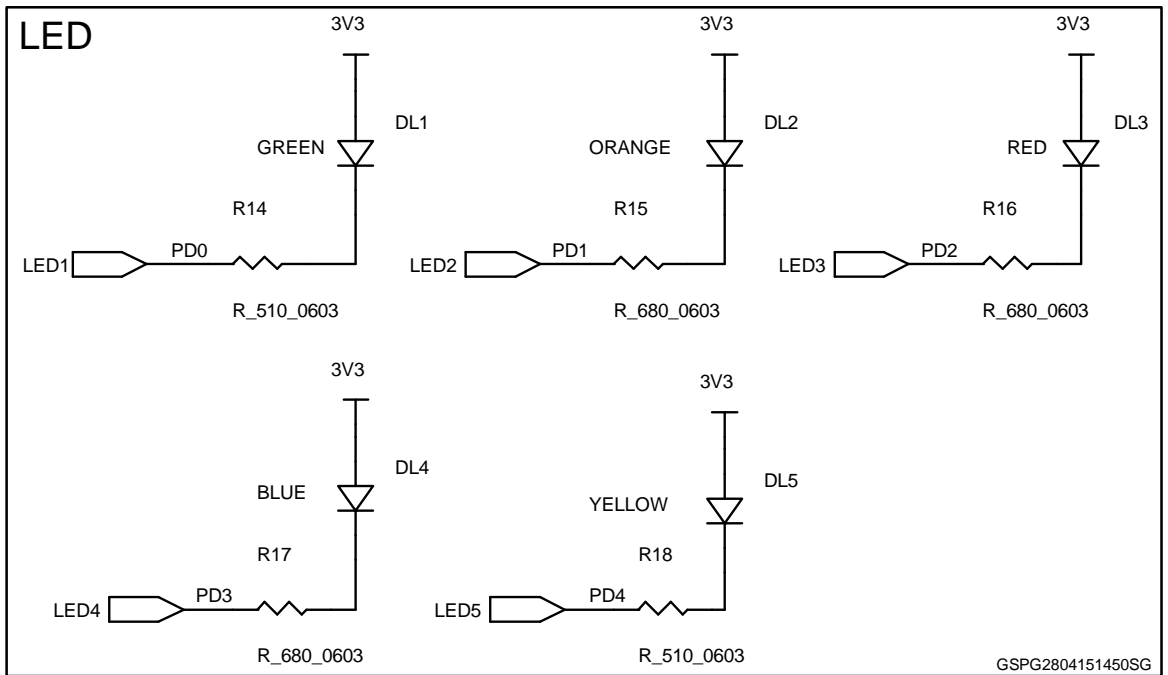

Figure 8: Power supply

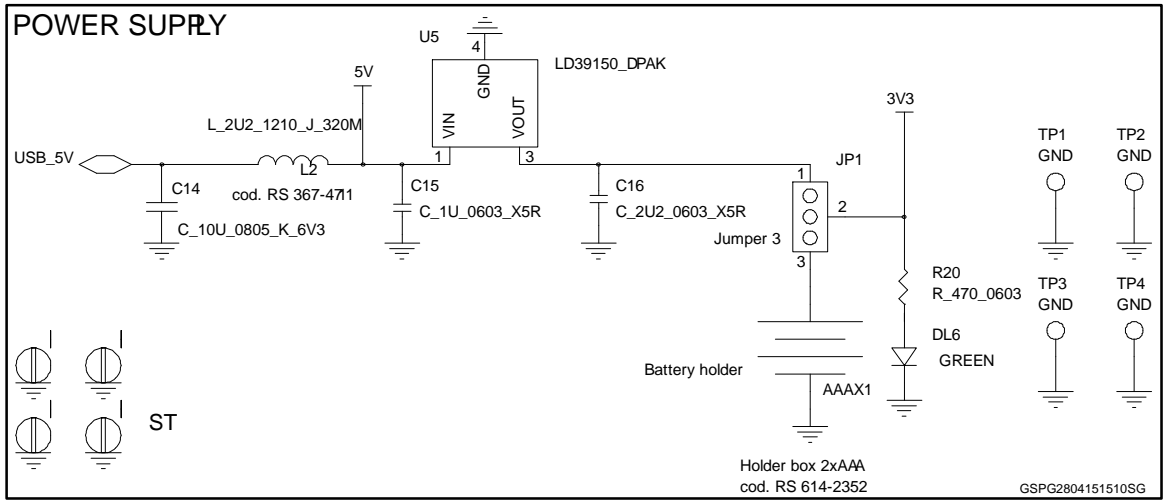

Figure 9: Button and joystick

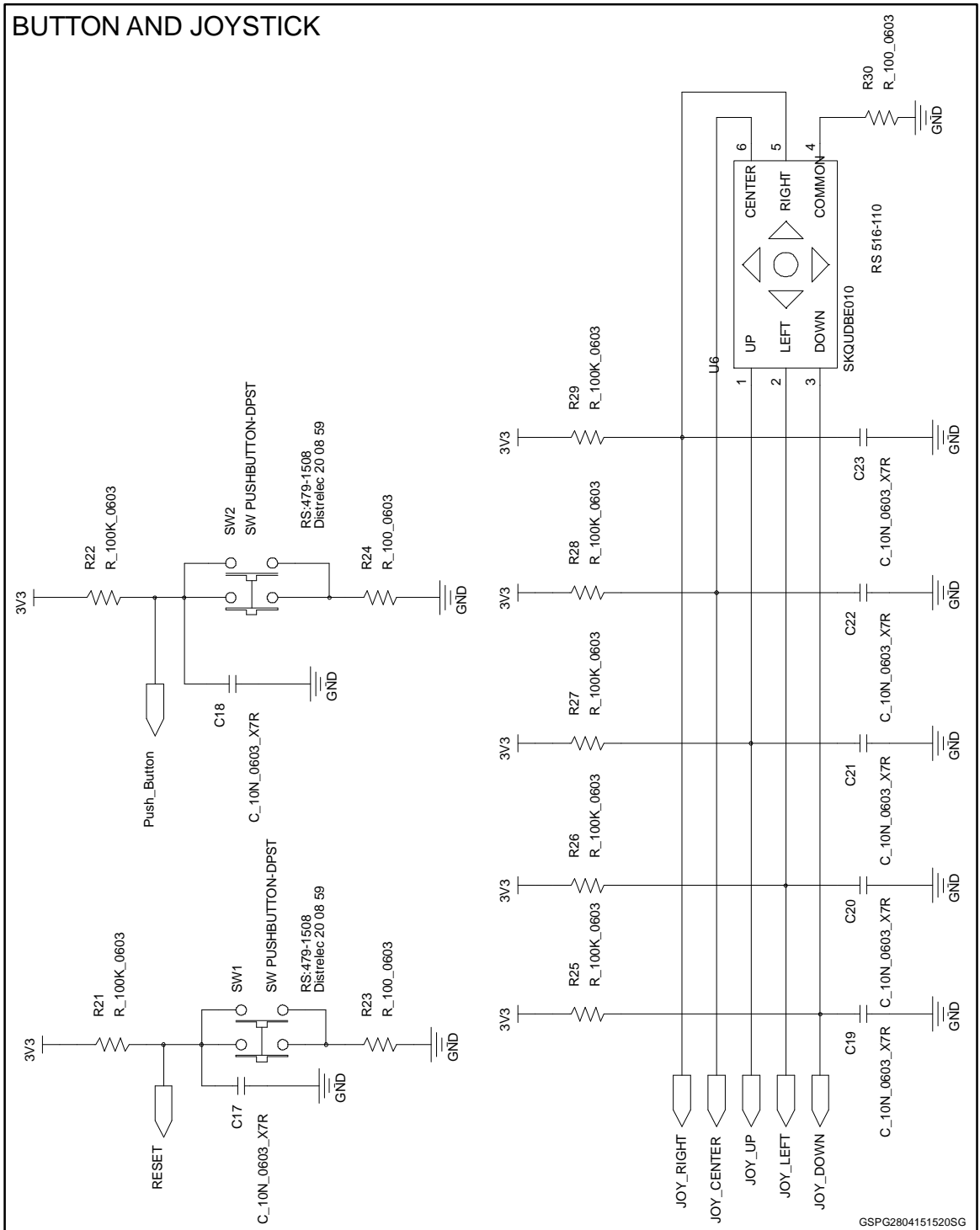
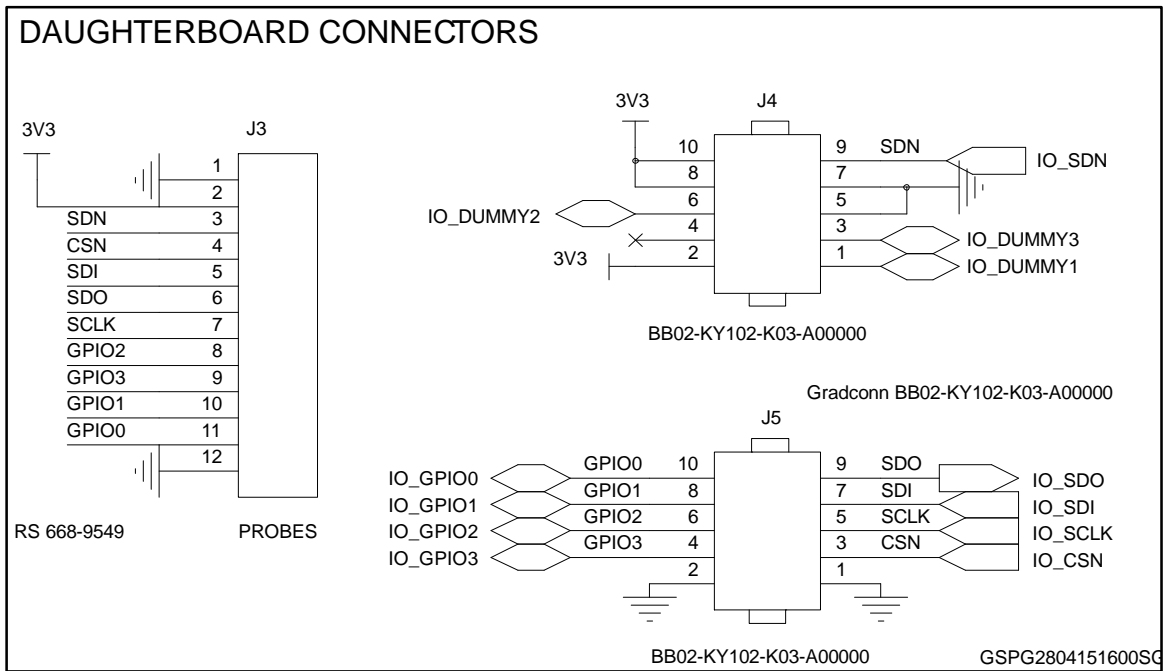



Figure 10: Daughterboard connectors



## 2 Revision history

Table 1: Document revision history

Date	Version	Changes
29-Apr-2015	1	Initial release.

**IMPORTANT NOTICE – PLEASE READ CAREFULLY**

STMicroelectronics NV and its subsidiaries ("ST") reserve the right to make changes, corrections, enhancements, modifications, and improvements to ST products and/or to this document at any time without notice. Purchasers should obtain the latest relevant information on ST products before placing orders. ST products are sold pursuant to ST's terms and conditions of sale in place at the time of order acknowledgement.

Purchasers are solely responsible for the choice, selection, and use of ST products and ST assumes no liability for application assistance or the design of Purchasers' products.

No license, express or implied, to any intellectual property right is granted by ST herein.

Resale of ST products with provisions different from the information set forth herein shall void any warranty granted by ST for such product.

ST and the ST logo are trademarks of ST. All other product or service names are the property of their respective owners.

Information in this document supersedes and replaces information previously supplied in any prior versions of this document.

© 2015 STMicroelectronics – All rights reserved