



S10040140P1

CATV Push Pull Hybrid 1000MHz 14dB

Product Description

The S10040140P1 is a Hybrid Push Pull amplifier module. The part employs GaAs/GaN die and is operated from 40 MHz to 1000 MHz. It provides excellent linearity and superior return loss performance with low noise and optimal reliability.



Package: SOT-115J

Functional Block Diagram

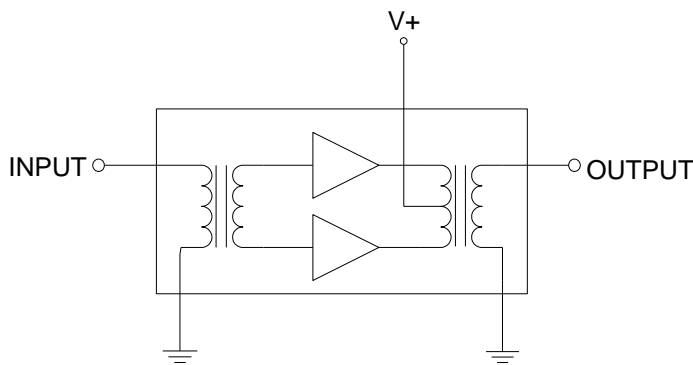

Product Features

- Excellent Linearity
- Superior Return Loss Performance
- Extremely Low Distortion
- Optimal Reliability
- Extremely Low Noise
- Unconditionally Stable Under all Terminations
- 14.0 dB Min Gain at 1000 MHz
- 260 mA Max. at 24 VDC

Applications

- 40 – 1000 MHz CATV Amplifier Systems

Ordering Information

Part No.	Description
S10040140P1	Box with 50 pcs

S10040140P1 Absolute Maximum

Parameter	Value / Range
RF Input Voltage (single tone)	65 dBmV
DC Supply over-voltage (5 minutes)	+30 V
Storage Temperature	-40 to 100 °C
Operating Mounting Base Temperature	-30 to 100 °C

Operation of this device outside the parameter ranges given above may cause permanent damage.

Electrical Specifications

Parameter	Test Conditions: $V_+ = 24V$, $T_{MB} = 30^\circ C$, $Z_S = Z_L = 75\Omega$	Min	Typ	Max	Unit
Operational Frequency Range	–	40	–	1000	MHz
Gain	$f_o = 50$ MHz		14.0		dB
Gain	$f_o = 1000$ MHz	14.0		15.5	
Gain Slope	40 to 1000 MHz ^[1]	0.5		1.5	
Gain Flatness	40 to 1000 MHz (Peak to Valley)			0.8	
Input Return Loss	$f_o = 40$ to 160 MHz	20.0		–	dB
	$f_o = 160$ to 1000 MHz	18.0		–	
Output Return Loss	$f_o = 40$ to 160 MHz	20.0		–	dB
	$f_o = 160$ to 870 MHz	18.0		–	
	$f_o = 870$ to 1000 MHz	15.0			
Noise Figure	$f_o = 50$ to 1000 MHz	–	4.5	5.5	dB
IDC			250	260	mA
CTB			-64	-60	dBc
XMOD	112 analog channels, NTSC frequency raster: 55.25 MHz to 745.25 MHz, +46dBmV flat output level. ^[2]		-55	-51	dBc
CSO			-64	-60	dBc

1. The slope is defined as the difference between the gain at the start frequency and the gain at the stop frequency.
2. Composite Triple Beat (CTB) - The CTB parameter is defined by ANSI/SCTE 6.
Composite Second Order (CSO) - The CSO parameter (both sum and difference products) is defined by ANSI/SCTE 6.
Cross Modulation (XMOD) - Cross modulation (XMOD) is defined by ANSI/SCTE 58, measured at baseband (selective voltmeter method), referenced to 100% modulation of the carrier being tested.

Package Drawing (Dimensions in millimeters)

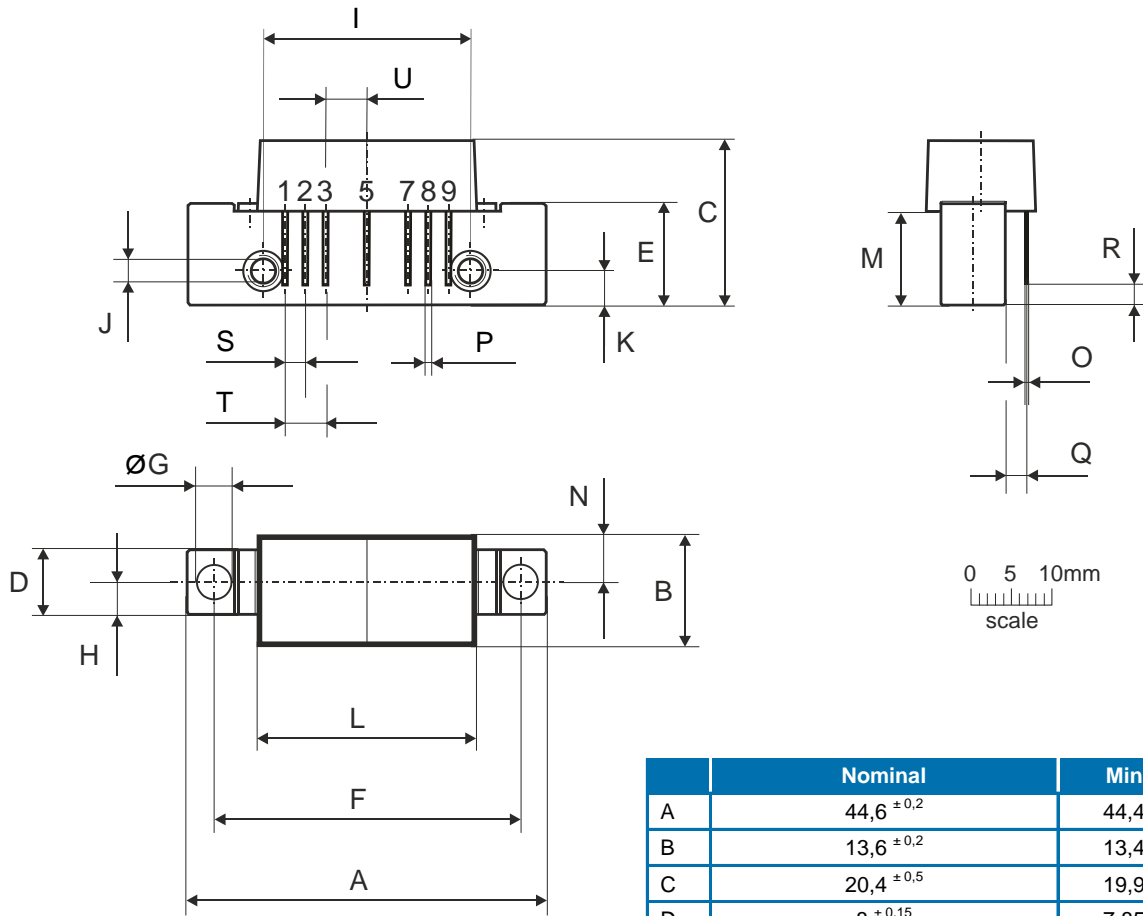

Notes:

European Projection

Pinning:

Pin	Name
1	Input
2-3	GND
4	
5	V+
6	
7-8	GND
9	Output

	Nominal	Min	Max
A	44,6 ^{±0,2}	44,4	44,8
B	13,6 ^{±0,2}	13,4	13,8
C	20,4 ^{±0,5}	19,9	20,9
D	8 ^{±0,15}	7,85	8,15
E	12,6 ^{±0,15}	12,45	12,75
F	38,1 ^{±0,2}	37,9	38,3
G	4 ^{+0,2 / -0,05}	3,95	4,2
H	4 ^{±0,2}	3,8	4,2
I	25,4 ^{±0,2}	25,2	25,6
J	UNC 6-32	-	-
K	4,2 ^{±0,2}	4,0	4,4
L	27,2 ^{±0,2}	27,0	27,4
M	11,6 ^{±0,5}	11,1	12,1
N	5,8 ^{±0,4}	5,4	6,2
O	0,25 ^{±0,02}	0,23	0,27
P	0,45 ^{±0,03}	0,42	0,48
Q	2,54 ^{±0,3}	2,24	2,84
R	2,54 ^{±0,5}	2,04	3,04
S	2,54 ^{±0,25}	2,29	2,79
T	5,08 ^{±0,25}	4,83	5,33
U	5,08 ^{±0,25}	4,83	5,33

Handling Precautions

Parameter	Rating	Standard
ESD – Human Body Model (HBM)	2	JEDEC JS-001
ESD – Charged Device Model (CDM)	C3	JEDEC JS-002



Caution!
ESD-Sensitive Device

RoHS Compliance

This part is compliant with 2011/65/EU RoHS directive (Restrictions on the Use of Certain Hazardous Substances in Electrical and Electronic Equipment) as amended by Directive 2015/863/EU.

Contact Information

For the latest specifications, additional product information, worldwide sales and distribution locations:

Web: www.qorvo.com

Tel: 1-844-890-8163

Email: customer.support@qorvo.com

Important Notice

The information contained herein is believed to be reliable; however, Qorvo makes no warranties regarding the information contained herein and assumes no responsibility or liability whatsoever for the use of the information contained herein. All information contained herein is subject to change without notice. Customers should obtain and verify the latest relevant information before placing orders for Qorvo products. The information contained herein or any use of such information does not grant, explicitly or implicitly, to any party any patent rights, licenses, or any other intellectual property rights, whether with regard to such information itself or anything described by such information. **THIS INFORMATION DOES NOT CONSTITUTE A WARRANTY WITH RESPECT TO THE PRODUCTS DESCRIBED HEREIN, AND QORVO HEREBY DISCLAIMS ANY AND ALL WARRANTIES WITH RESPECT TO SUCH PRODUCTS WHETHER EXPRESS OR IMPLIED BY LAW, COURSE OF DEALING, COURSE OF PERFORMANCE, USAGE OF TRADE OR OTHERWISE, INCLUDING THE IMPLIED WARRANTIES OF MERCHANTABILITY AND FITNESS FOR A PARTICULAR PURPOSE.**

Without limiting the generality of the foregoing, Qorvo products are not warranted or authorized for use as critical components in medical, life-saving, or life-sustaining applications, or other applications where a failure would reasonably be expected to cause severe personal injury or death.

Copyright 2016 © Qorvo, Inc. | Qorvo is a registered trademark of Qorvo, Inc.