

## PMU for Bluetooth Headsets

Check for Samples: [TPS65720](#) [TPS65721](#)

### FEATURES

- Battery Charger With Power Path Management
- 28 V Rated Power Path With:
  - 100 mA Input Current Limit
  - 500 mA input Current Limit
- 300 mA Charge Current
- 200 mA Step-Down Converter for TPS65720
- 400 mA Step-Down Converter for TPS65721
- Up to 92% Efficiency
- $V_{IN}$  Range for DCDC Converter From 2.3V to 5.6V
- 2.25 MHz Fixed Frequency Operation
- Power Save Mode at Light Load Current
- Output Voltage Accuracy in PWM Mode  $\pm 2\%$
- 100% Duty Cycle for Lowest Dropout
- 1 General Purpose 200mA LDO
- $V_{IN}$  Range for LDO From 1.8V to 5.6V
- I2C Compatible Interface
- 4GPIOs
- Available in a 25 Ball WCSP With 0,4mm Pitch and in 4mm x 4mm 32-Pin QFN Package

### APPLICATIONS

- Bluetooth Headsets
- Handheld Equipment

### DESCRIPTION

The TPS65720 is a small power management unit targeted for Bluetooth headsets or other portable low power consumer end equipments. It contains an USB friendly Lithium-Ion battery charger, a high efficient step down converter, a low dropout linear regulator and additional supporting functions. The device is controlled by an I2C interface. Several settings can be customized by the use of non volatile memory which is factory programmed. The 2.25MHz step-down converter enters a low power mode at light load for maximum efficiency across the widest possible range of load currents. For low noise applications the devices can be forced into fixed frequency PWM mode using the I2C compatible interface. The device allows the use of small inductors and capacitors to achieve a small solution size. TPS65720 provides an output current of up to 200mA on the DCDC converter. The TPS65720 also integrates one 200mA LDO. The LDO operates with an input voltage range between 1.8V and 5.6V allowing it to be supplied from the output of the step-down converter or directly from the system voltage.

The TPS65720 comes in a small 25-ball wafer chip scale package (WCSP) with 0,4mm ball pitch or a 4mm x 4mm QFN package with a 0,4mm pitch (TPS65721).

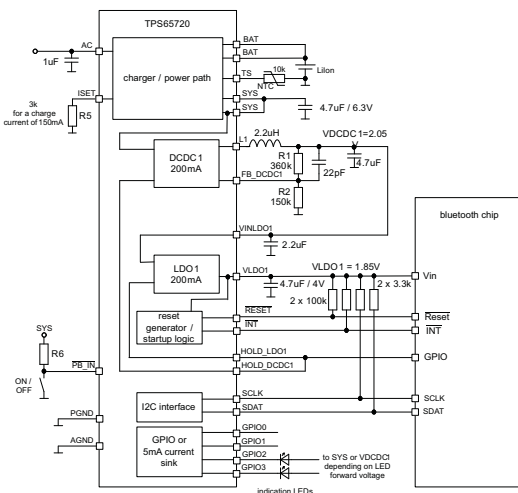

Please be aware that an important notice concerning availability, standard warranty, and use in critical applications of Texas Instruments semiconductor products and disclaimers thereto appears at the end of this data sheet.

PowerPAD is a trademark of Texas Instruments.

PRODUCTION DATA information is current as of publication date. Products conform to specifications per the terms of the Texas Instruments standard warranty. Production processing does not necessarily include testing of all parameters.

Copyright © 2009, Texas Instruments Incorporated



This integrated circuit can be damaged by ESD. Texas Instruments recommends that all integrated circuits be handled with appropriate precautions. Failure to observe proper handling and installation procedures can cause damage.

ESD damage can range from subtle performance degradation to complete device failure. Precision integrated circuits may be more susceptible to damage because very small parametric changes could cause the device not to meet its published specifications.

### ORDERING INFORMATION

T <sub>A</sub>	PART NUMBER <sup>(1)</sup>	SIZE FOR WCSP VERSION	PACKAGE CODE	PACKAGE	PACKAGE MARKING
-40°C TO 85°C	TPS65720	D = 2105 μm ±25 μm E = 2105 μm ±25 μm	YFF	WCSP	TPS65720
-40°C TO 85°C	TPS65721		RSN	QFN <sup>(1)</sup>	65720

(1) The RSN and YFF package is available in tape and reel. Add R suffix (TPS65720YFFR; TPS65721RSNR) to order quantities of 3000 parts per reel. Add T suffix (TPS65720YFFT; TPS65721RSNT) to order quantities of 250 parts per reel.

### ABSOLUTE MAXIMUM RATINGS

over operating free-air temperature range (unless otherwise noted)

	VALUE / UNIT
Input voltage range on all pins except A/PGND, AC, GPIOx pins with respect to AGND	-0.3 to 7 V
Input voltage range on GPIOx pins with respect to AGND	-0.3 to V <sub>SYS</sub>
Input voltage range on AC pin with respect to AGND	-0.3 to 28 V
Voltage range on pin VLDO1, FB_LDO1, TS_OUT, TS with respect to AGND	-0.3 to 3.6 V
Current at AC, BAT, SYS, L1, VLDO1, VINLDO1, PGND	600 mA
Current at GPIOx, AGND	20 mA
Current at all other pins	3 mA
Continuous total power dissipation	See dissipation rating table
Operating free-air temperature, T <sub>A</sub>	-40°C to 85°C
Maximum junction temperature, T <sub>J</sub>	125°C
Storage temperature, T <sub>ST</sub>	-65°C to 150°C

### DISSIPATION RATINGS<sup>(1)</sup>

PACKAGE	R <sub>θJA</sub>	T <sub>A</sub> ≤ 25°C POWER RATING	DERATING FACTOR ABOVE T <sub>A</sub> = 25°C	T <sub>A</sub> = 70°C POWER RATING	T <sub>A</sub> = 85°C POWER RATING
YFF	55 K/W	1.8 W	18 mW/K	1 W	0.7 W
RSN	38 K/W	2.6 W	26 mW/K	1.4 W	1 W

(1) The thermal resistance was measured on a high K board.

### RECOMMENDED OPERATING CONDITIONS

		MIN	NOM	MAX	UNIT
V <sub>AC</sub>	Input voltage range at AC pin	4.35		28	V
V <sub>SYS</sub>	Voltage range at SYS pin	2.2		5.6	V
I <sub>INUSB</sub>	Input current at AC			500	mA
I <sub>OUTSYS</sub>	Output current at SYS			400	mA
I <sub>BAT</sub>	Average current into / out of BAT pin			300	mA
V <sub>INDCDC1</sub>	Input voltage range for step-down converter DCDC1	2.3		5.6	V
V <sub>DCDC1</sub>	Output voltage range for DCDC1 step-down converter; externally adjustable	0.6		V <sub>INDCDC1</sub>	V
I <sub>OUTDCDC1</sub>	Output current at L			400	mA
L	Inductor at L <sup>(1)</sup>	2.2	3.3	4.7	μH
V <sub>INLDO1</sub>	Input voltage range for LDO1	1.8		V <sub>SYS</sub>	V
V <sub>LDO1</sub>	Output voltage range for LDO1	0.8		3.3	V
I <sub>LDO1</sub>	Output current at LDO1			200	mA

(1) See application section for more details

**RECOMMENDED OPERATING CONDITIONS (continued)**

		MIN	NOM	MAX	UNIT
C <sub>INAC</sub>	Input capacitor at AC <sup>(1)</sup>	0.1		1	μF
C <sub>BAT</sub>	Capacitor at BAT <sup>(1)</sup>	0.1		4.7	μF
C <sub>SYS</sub>	Capacitor at SYS <sup>(1)</sup>	4.7		10	μF
C <sub>INDCDC1</sub>	Input capacitor at V <sub>INDCDC1</sub> <sup>(1)</sup> ; if connected to SYS, only one 4.7μF cap required for SYS and C <sub>INDCDC1</sub>	4.7			μF
C <sub>OUTDCDC1</sub>	Output capacitor at V <sub>DCDC1</sub> <sup>(1)</sup>	4.7	10	22	μF
C <sub>INLDO1</sub>	Input capacitor at VINLDO1 <sup>(1)</sup>	2.2			μF
C <sub>OUTLDO1</sub>	Output capacitor at LDO1 <sup>(1)</sup>	2.2			μF
R <sub>ISET</sub>	Minimum R <sub>ISET</sub> value for proper operation; lower values may trigger the short circuit protection on ISET	700			Ω
T <sub>A</sub>	Operating ambient temperature	-40		85	°C
T <sub>J</sub>	Operating junction temperature	-40		125	°C

**ELECTRICAL CHARACTERISTICS**

V<sub>SYS</sub> = 3.6V, V<sub>DCDC1</sub> = 2.05V, PFM mode, L = 3.3μH, C<sub>OUTDCDC1</sub> = 4.7μF, V<sub>INLDO1</sub> = 2.05V, V<sub>LDO1</sub> = 1.85V, T<sub>A</sub> = -40°C to 85°C  
 typical values apply in a temperature range of 10°C to 35°C (unless otherwise noted)

PARAMETER		TEST CONDITIONS	MIN	TYP	MAX	UNIT
<b>SUPPLY CURRENT</b>						
I <sub>Q</sub>	Operating quiescent current when only DCDC1 converter is enabled	DCDC1 enabled, I <sub>OUT</sub> = 0mA. PFM mode enabled; device not switching		36	45	μA
		DCDC1 enabled, I <sub>OUT</sub> = 0mA. PWM mode		2.8		mA
I <sub>Q</sub>	Operating quiescent current when LDO1 and DCDC1 are enabled	Current into BAT pin (PFM mode)		33	50	μA
		Current into VINLDO1		13	18	μA
I <sub>SD</sub>	Shutdown current after voltage was applied to BAT but device never enabled before (shipping mode)	For VINLDO1=0V (LDO1 supplied by DCDC1); powered by VBAT=3.6V		4	13	μA
	Shutdown current after first power-up	For VINLDO1=0V (LDO1 supplied by DCDC1); powered by VBAT=3.6V		12	17	μA
	Shutdown current after first power-up	For VINLDO1≠0V (LDO1 supplied by SYS); powered by VBAT=3.6V		12	18	μA

## ELECTRICAL CHARACTERISTICS (continued)

$V_{SYS} = 3.6V$ ,  $V_{DCDC1} = 2.05V$ , PFM mode,  $L = 3.3\mu H$ ,  $C_{OUTDCDC1} = 4.7\mu F$ ,  $V_{INLDO1} = 2.05V$ ,  $V_{LDO1} = 1.85V$ ,  $T_A = -40^\circ C$  to  $85^\circ C$   
typical values apply in a temperature range of  $10^\circ C$  to  $35^\circ C$  (unless otherwise noted)

PARAMETER		TEST CONDITIONS	MIN	TYP	MAX	UNIT
<b>SDAT, SCLK, PB_IN, HOLD, GPIO0 TO GPIO3, INT, RESET, THRESHOLD</b>						
$V_{IH}$	High level input voltage for SCLK, SDAT, GPIOx, HOLD_DCDC1, HOLD_LDO1, PB_IN	GPIOs configured as input	1.2		$V_{SYS}$	V
$V_{IL}$	Low level input voltage for SCLK, SDAT, GPIOx, HOLD_DCDC1, HOLD_LDO1, PB_IN	GPIOs configured as input	0		0.4	V
$V_{OL}$	Low level output voltage for SDAT, GPIOx, INT, RESET	GPIOs configured as output; $I_o = 1mA$ ; no internal pull-up	0		0.4	V
$I_{OL}$	Sink current for GPIO2, GPIO3	GPIO2, GPIO3 configured as current sink; $V_{OL} = 0.4V$ ; for $T_J = 0^\circ C$ to $85^\circ C$	-20%	5	20%	mA
	Sink current for GPIOx	GPIOx configured as open drain output; output = LOW			3	mA
$V_{OL}$	Minimum voltage for proper current regulation from GPIO2 or GPIO3 to GND if programmed as a current sink	$I_o = 5mA$ ; current sink turned on	0.4			V
$V_{RESET-falling}$	LDO1 out of regulation reset voltage	Falling edge; $\overline{RESET}$ is asserted LOW for TPS65720	$V_{LDO1}$ , nom-13%		$V_{LDO1}$ , nom-7%	V
$V_{RESET-rising}$		Rising edge; $\overline{RESET}$ is released HIGH for TPS65720 after $T_{RESET}$		$V_{LDO1}$ , nom-4%		V
$T_{RESET}$	Reset delay time on pin $\overline{RESET}$	Low to high transition of $\overline{RESET}$ pin, depending on setting of Bit RESET_DELAY	9 70	11 90	13 110	ms
		HIGH to LOW transition of $\overline{RESET}$ pin $\overline{RESET}$ will go low by HOLD pin going LOW AND HOLD Bit set to 0 OR voltage at $V_{reset}$ falling below the threshold		10		$\mu s$
$V_{THRESHOLD\_down}$	Threshold voltage for reset input	Falling voltage; QFN package only	-3%	570	3%	mV
$V_{THRESHOLD\_hys}$	Hysteresis on THRESHOLD	Rising voltage; QFN package only		30		mV
$T_{debounce}$	Debounce time at $\overline{PB\_IN}$	Rising and falling voltage	39	50	60	ms
$I_{LKG}$	Input leakage current	$\overline{PB\_IN}$ , SDAT, SCLK, GPIOx configured as output, INT, $\overline{RESET}$ , output high impedance			0.2	$\mu A$
<b>STEP-DOWN CONVERTER</b>						
$V_{SYS}$	Input voltage for DCDC1		2.3		5.6	V
UVLO	Internal undervoltage lockout threshold hysteresis	$V_{SYS}$ falling	2.15	2.2	2.25	V
		$V_{SYS}$ rising		120		mV
<b>POWER SWITCH</b>						
$R_{DS(ON)}$	High side MOSFET on-resistance	$V_{SYS} = V_{INDCDC1} = 3.6V$ , YFF package		350	600	m $\Omega$
		$V_{SYS} = V_{INDCDC1} = 3.6V$ , RSN package		400	650	
$I_{LK\_HS}$	High side MOSFET leakage current	$V_{DS} = 5.6V$			1	$\mu A$
$R_{DS(ON)}$	Low side MOSFET on-resistance	$V_{INDCDC1/2} = 3.6V$ , YFF package		300	500	m $\Omega$
		$V_{INDCDC1/2} = 3.6V$ , RSN package		350	550	
$I_{LK\_LS}$	Low side MOSFET leakage current	$V_{DS} = 5.6V$			1	$\mu A$
$I_{LIMF}$	Forward current limit high-side and low side MOSFET	$2.3V \leq V_{IN} \leq 5.6V$ , TPS65720	425	600	775	mA
		$2.3V \leq V_{IN} \leq 5.6V$ , TPS65721	625	850	1150	
$I_o$	DC output current	$V_{SYS} > 2.7V$ ; TPS65720			200	mA
		$V_{SYS} > 2.7V$ ; TPS65721			400	
<b>OSCILLATOR</b>						
$f_{SW}$	Oscillator Frequency		2.03	2.25	2.48	MHz
<b>OUTPUT</b>						
$V_{OUT}$	Output Voltage Range		0.6		$V_{in}$	V
$V_{FB}$	Feedback voltage			0.6		V
$I_{FB}$	FB pin input current				0.1	$\mu A$
$V_{OUT}$	DC Output voltage accuracy <sup>(1)</sup>	$V_{IN} = 2.3V$ to $5.6V$ ; PFM operation, $0mA < I_{OUT} < I_{OUTMAX}$		1%	3%	
		$V_{IN} = 2.3V$ to $5.6V$ , PWM operation, $0mA < I_{OUT} < I_{OUTMAX}$	-2%		2%	
	DC output voltage load regulation	PWM operation		0.5		%/A
$V_{PGOOD-falling}$	PGOOD threshold at falling output voltage	<PGOODZ_DCDC1> is set to 1	$V_{DCDC1}$ , nom-14%		$V_{DCDC1}$ , nom-7%	V
$V_{PGOOD-rising}$	PGOOD threshold at rising output voltage	<PGOODZ_DCDC1> is set to 0		$V_{DCDC1}$ , nom-5%		V
$t_{Start}$	Start-up time	Time from active EN to Start switching		170		$\mu s$
$t_{Ramp}$	$V_{OUT}$ ramp time	Time to ramp from 5% to 95% of $V_{OUT}$		250		$\mu s$

(1) Output voltage specification does not include tolerance of external voltage programming resistors

## ELECTRICAL CHARACTERISTICS (continued)

$V_{SYS} = 3.6V$ ,  $V_{DCDC1} = 2.05V$ , PFM mode,  $L = 3.3\mu H$ ,  $C_{OUTDCDC1} = 4.7\mu F$ ,  $V_{INLDO1} = 2.05V$ ,  $V_{LDO1} = 1.85V$ ,  $T_A = -40^\circ C$  to  $85^\circ C$   
 typical values apply in a temperature range of  $10^\circ C$  to  $35^\circ C$  (unless otherwise noted)

PARAMETER	TEST CONDITIONS	MIN	TYP	MAX	UNIT
$R_{DIS}$	Internal discharge resistor at L DCDC1 disabled; the discharge function can be disabled as an EEPROM option	300	400		$\Omega$
<b>THERMAL PROTECTION FOR DCDC1 AND LDO1</b>					
$T_{SD}$	Thermal shutdown	Increasing junction temperature		150	$^\circ C$
	Thermal shutdown hysteresis	Decreasing junction temperature		30	$^\circ C$
<b>VLDO1 LOW DROPOUT REGULATOR</b>					
$V_{INLDO}$	Input voltage range for LDO1	1.8		5.6	V
$V_{LDO1}$	LDO1 output voltage range	0.8		3.3	V
$V_{LDO1}$	LDO1 output voltage	Default output voltage for TPS65720 only		1.85	V
$V_{FB\_LDO1}$	Feedback voltage	Externally adjustable version only: TPS65721		0.8	V
$I_{FB\_LDO1}$	FB pin input current			0.1	$\mu A$
$I_O$	Output current for LDO1			200	mA
$I_{SC}$	LDO1 short circuit current limit	$VLDO1 = GND$ ; $V_{INLDO1} = 2.05V$		350	500
	Dropout voltage at LDO1, YFF package	$I_O = 200$ mA, $V_{INLDO} = 2.05$ V		180	mV
	Dropout voltage at LDO1, RSN package	$I_O = 200$ mA, $V_{INLDO} = 2.05$ V		120	mV
	Output voltage accuracy for LDO1	$I_O = 200$ mA		-1.5%	2.5%
	Line regulation for LDO1	$V_{INLDO1} = V_{LDO1} + 0.5V$ (min. 1.8V) to 5.6 V (V <sub>SYS</sub> ), $I_O = 50$ mA		-1%	1%
	Load regulation for LDO1	$I_O = 0$ mA to 200 mA for LDO1		-1%	2%
	PGOOD debounce time	Internal PGOOD comparator at VOUTLDO1 is debounced by		80	$\mu s$
$t_{Ramp}$	$V_{OUT}$ Ramp time	Internal soft-start when LDO is enabled; Time to ramp from 5% to 95% of $V_{OUT}$		250	$\mu s$
$R_{DIS}$	Internal discharge resistor at VLDO1	250	400		$\Omega$
<b>BATTERY VOLTAGE COMPARATOR</b>					
	Battery voltage comparator threshold voltage	Depending on Bits <VBAT0>, <VBAT1>; falling voltage		-3%	3%
	Battery voltage comparator threshold voltage hysteresis	Rising voltage		200	mV
<b>POWER PATH</b>					
$V_{UVLO}$	Undervoltage lockout	$V_{AC}$ : 0V $\rightarrow$ 4V		3.2	3.3
$V_{HYS-UVLO}$	Hysteresis on UVLO	$V_{AC}$ : 4V $\rightarrow$ 0V		200	300
$V_{IN-DT}$	Input power detection threshold	(Input power detected if $V_{IN} > V_{BAT} + V_{IN-DT}$ ) $V_{BAT} = 3.6V$ , $V_{IN}$ : 3.5V $\rightarrow$ 4V		40	80
$V_{HYS-INDT}$	Hysteresis on VIN-DT	$V_{BAT} = 3.6$ V, $V_{IN}$ : 4V $\rightarrow$ 3.5V		20	
$t_{DGL(PGOOD)}$	Deglintch time, input power detected status	Time measured from $V_{IN}$ : 0V $\rightarrow$ 5V 1 $\mu s$ rise-time to PGOOD = LO		2	
$V_{OVP}$	Input over-voltage protection threshold	$V_{AC}$ : 5 V $\rightarrow$ 7 V		6.4	6.6
$V_{HYS-OVP}$	Hysteresis on OVP	$V_{AC}$ : 11V $\rightarrow$ 5V		105	
$t_{BLK(OVP)}$	Input over-voltage blanking time			50	$\mu s$
$t_{REC(OVP)}$	Input over-voltage recovery time	Time measured from $V_{AC}$ : 11V $\rightarrow$ 5V 1 $\mu s$ fall-time to <CH_PGOOD>=0		2	
$V_{DO(AC-SYS)}$	AC pin to SYS pin dropout voltage $V_{AC} - V_{SYS}$	$I_{SYS} = 0.3A$ , $V_{AC} = 4.35V$ , $V_{BAT} = 4.2V$ ; YFF package		170	285
		$I_{SYS} = 0.3A$ , $V_{AC} = 4.35V$ , $V_{BAT} = 4.2V$ ; RSN package		210	325
$V_{DO(BAT-SYS)}$	Battery to SYS pin dropout voltage $V_{BAT} - V_{SYS}$	$I_{SYS} = 0.2A$ , $V_{AC} = 0V$ , $V_{BAT} > 3V$ ; YFF package			80
		$I_{SYS} = 0.2A$ , $V_{AC} = 0V$ , $V_{BAT} > 3V$ ; RSN package			120
$V_{SYS(REG)}$	SYS pin voltage regulation selectable register <CHGCONFIG> Bits <VSYS1>; <VSYS0>	00: $V_{AC} > V_{SYS} + V_{DO(AC-SYS)}$ , $V_{BAT} < 3.3V$	-5%	3.4	5%
		00: $V_{AC} > V_{SYS} + V_{DO(AC-SYS)}$ , $V_{BAT} \geq 3.3V$	-5%	$V_{BAT} + 200mV$	5%
		01: $V_{AC} > V_{SYS} + V_{DO(AC-SYS)}$	-5%	4.4	5%
		10: $V_{AC} > V_{SYS} + V_{DO(AC-SYS)}$	-5%	5.0	5%
		11: $V_{AC} > V_{SYS} + V_{DO(AC-SYS)}$	-5%	5.5	5%
$I_{AC-MAX}$	Maximum Input Current Register <CHCONFIG0>	Bit <AC input current1, AC input current0> = 00	90	95	100
		Bit <AC input current1, AC input current0> = 01 or 10	450	475	500
$V_{AC-LOW}$	Input voltage threshold when input current is reduced	Input current is reduced if voltage at AC falls below VAC-LOW to keep the AC voltage above 4.5V		4.35	4.5
$V_{DPM}$	Output voltage threshold when charging current is reduced	Bit <V_DPPM> = 1			$V_{O(REG)} - 100mV$
	Register <CHCONFIG2>	Bit <V_DPPM> = 0		4.3	V

**ELECTRICAL CHARACTERISTICS (continued)**

V<sub>SYS</sub> = 3.6V, V<sub>DCDC1</sub> = 2.05V, PFM mode, L = 3.3μH, C<sub>OUTDCDC1</sub> = 4.7μF, V<sub>INLDO1</sub>=2.05V, V<sub>LDO1</sub>=1.85V, T<sub>A</sub> = -40°C to 85°C  
typical values apply in a temperature range of 10°C to 35°C (unless otherwise noted)

PARAMETER		TEST CONDITIONS	MIN	TYP	MAX	UNIT
V <sub>BSUP1</sub>	Enter battery supplement mode			$V_{OUT} \leq V_{BAT} - 40mV$		V
V <sub>BSUP2</sub>	Exit battery supplement mode			$V_{OUT} \geq V_{BAT} - 20mV$		V
V <sub>O(SC1)</sub>	Output short-circuit detection threshold, power-on		0.8	0.9	1	V
V <sub>O(SC2)</sub>	Output short-circuit detection threshold, supplement mode $V_{BAT} - V_{OUT} > V_{O(SC2)}$ indicates short-circuit		200	250	300	mV
t <sub>DGL(SC2)</sub>	Deglintch time, supplement mode short circuit			250		μs
t <sub>REC(SC2)</sub>	Recovery time, supplement mode short circuit			60		ms
<b>BATTERY CHARGER</b>						
<b>QUIESCENT CURRENT</b>						
I <sub>IACSTDBY</sub>	Standby current into AC pin	V <sub>IN</sub> = 5V; ACinputcurrent[1,0]=11		60	80	μA
		V <sub>IN</sub> = 28V; ACinputcurrent[1,0]=11			530	μA
I <sub>CC</sub>	Active supply current, AC pin	V <sub>IN</sub> = 5V, no load on DCDC1, LDO1, SYS pin, VSYS[1,0]=11; ACinputcurrent[1,0]=10; CH_EN=0			2	mA
IBAT(SC)	Source current for BAT pin short-circuit detection		4	7.5	11	mA
VBAT(SC)	BAT pin short-circuit detection threshold		1.6	1.8	2.0	V
V <sub>O(BATREG)</sub>	Battery charger voltage	Depending on setting in CHGCONFIG3 And internal EEPROM Default = 4.2V	-1%	4.15	1%	V
			-1%	4.175	1%	
			-1%	4.20	1%	
			-1%	4.225	1%	
			-1%	4.25	1%	
			-1%	4.275	1%	
			-1%	4.30	1%	
V <sub>LOWV</sub>	Pre-charge to fast-charge transition threshold		2.9	3.0	3.1	V
t <sub>DGL1(LOWV)</sub>	Deglintch time on pre-charge to fast-charge transition			25		ms
t <sub>DGL2(LOWV)</sub>	Deglintch time on fast-charge to pre-charge transition			25		ms
I <sub>CHG</sub>	Maximum battery fast charge current	$V_{BAT(REG)} > V_{BAT} > V_{LOWV}$ ; V <sub>IN</sub> = V <sub>AC</sub> or V <sub>USB</sub> = 5V	300			mA
	Minimum battery fast charge current			10	mA	
	Battery fast charge current set factor		$V_{BAT} > V_{LOWV}$ ; V <sub>IN</sub> = 5V, I <sub>IN-MAX</sub> > I <sub>CHG</sub> , No load on SYS pin, thermal loop not active, DPPM loop not active	K <sub>ISET</sub> / R <sub>ISET</sub>		A
K <sub>ISET</sub>	Fast charge current factor	at 300mA for ICH_SCL[1,0]=11 (charge current scaling is 100% of ISET value)	-15%	450	15%	AΩ
		at 40mA for ICH_SCL[1,0]=11 (charge current scaling is 100% of ISET value)	-20%	450	20%	
		at 225mA range for ICH_SCL[1,0]=10 (charge current scaling is 75% of ISET value)	-15%	338	15%	
		at 30mA for ICH_SCL[1,0]=10 (charge current scaling is 75% of ISET value)	-20%	338	20%	
		at 150mA for ICH_SCL[1,0]=01 (charge current scaling is 50% of ISET value)	-10%	225	10%	
		at 20mA for ICH_SCL[1,0]=01 (charge current scaling is 50% of ISET value)	-15%	225	15%	
		at 75mA for ICH_SCL[1,0]=00 (charge current scaling is 25% of ISET value)	-10%	112	10%	
		at 10mA for ICH_SCL[1,0]=00 (charge current scaling is 25% of ISET value)	-20%	112	20%	
I <sub>PRECHG</sub>	Pre-charge current	for I_PRE[1,0]=11 (pre-charge current scaling is 20% of charge current)	0.15xI <sub>CHG</sub>	0.2xI <sub>CHG</sub>	0.25xI <sub>CHG</sub>	
		for I_PRE[1,0]=10 (pre-charge current scaling is 15% of charge current)	0.11xI <sub>CHG</sub>	0.15xI <sub>CHG</sub>	0.19xI <sub>CHG</sub>	
		for I_PRE[1,0]=01 (pre-charge current scaling is 10% of charge current)	0.07xI <sub>CHG</sub>	0.1xI <sub>CHG</sub>	0.13xI <sub>CHG</sub>	
		for I_PRE[1,0]=00 (pre-charge current scaling is 5% of charge current)	0.03xI <sub>CHG</sub>	0.05xI <sub>CHG</sub>	0.08xI <sub>CHG</sub>	

## ELECTRICAL CHARACTERISTICS (continued)

$V_{SYS} = 3.6V$ ,  $V_{DCDC1} = 2.05V$ , PFM mode,  $L = 3.3\mu H$ ,  $C_{OUTDCDC1} = 4.7\mu F$ ,  $V_{INLDO1} = 2.05V$ ,  $V_{LDO1} = 1.85V$ ,  $T_A = -40^{\circ}C$  to  $85^{\circ}C$   
 typical values apply in a temperature range of  $10^{\circ}C$  to  $35^{\circ}C$  (unless otherwise noted)

PARAMETER	TEST CONDITIONS	MIN	TYP	MAX	UNIT
$I_{TERM}$ Charge current value for termination detection threshold (internally set)	for $I\_TERM[1,0]=11$ (termination current is 20% of charge current)	$0.15 \times I_{CHG}$	$0.2 \times I_{CHG}$	$0.27 \times I_{CHG}$	
	for $I\_TERM[1,0]=10$ (termination current is 15% of charge current)	$0.11 \times I_{CHG}$	$0.15 \times I_{CHG}$	$0.21 \times I_{CHG}$	
	for $I\_TERM[1,0]=01$ (termination current is 10% of charge current)	$0.07 \times I_{CHG}$	$0.1 \times I_{CHG}$	$0.15 \times I_{CHG}$	
	for $I\_TERM[1,0]=00$ (termination current is 5% of charge current)	$0.03 \times I_{CHG}$	$0.05 \times I_{CHG}$	$0.08 \times I_{CHG}$	
$t_{DGL(TERM)}$ Deglitch time, termination detected			25		ms
$V_{RCH}$ Recharge detection threshold	Voltage below nominal charger voltage	165	100	60	mV
$t_{DGL(RCH)}$ Deglitch time, recharge threshold detected			62.5		ms
$t_{DGL(NO-IN)}$ Delay time, input power loss to charger turn-off	$V_{BAT} = 3.6V$ . Time measured from $V_{IN}$ : $5V \rightarrow 3.3V$ 1 $\mu s$ fall-time		20		ms
$I_{BAT(DET)}$ Sink current for battery detection		5	7.5	10	mA
$t_{DET}$ Battery detection timer			250		ms
$T_{CHG}$ Charge safety timer	Safety timer range selectable by I2C; default setting without DPPM or thermal loop active	-35%	5	35%	h
$T_{PRECHG}$ Precharge timer	Pre charge timer range; default setting	-35%	30	35%	min

**ELECTRICAL CHARACTERISTICS (continued)**

$V_{SYS} = 3.6V$ ,  $V_{DCDC1} = 2.05V$ , PFM mode,  $L = 3.3\mu H$ ,  $C_{OUTDCDC1} = 4.7\mu F$ ,  $V_{INLDO1} = 2.05V$ ,  $V_{LDO1} = 1.85V$ ,  $T_A = -40^{\circ}C$  to  $85^{\circ}C$   
typical values apply in a temperature range of  $10^{\circ}C$  to  $35^{\circ}C$  (unless otherwise noted)

PARAMETER		TEST CONDITIONS	MIN	TYP	MAX	UNIT
<b>BATTERY-PACK NTC MONITOR</b>						
RNTC <sub>HOT</sub>	Thermistor high temperature detection resistance (equals 45°C for 10k NTC; B=3380)	Hot temperature detected and charging suspended when the resistance of the battery-NTC is lower than RNTC <sub>HOT</sub>	4.3	5	5.7	kΩ
	Thermistor high temperature detection resistance (equals 50°C for 10k NTC; B=3380)		3.5	4.1	4.8	kΩ
	Thermistor high temperature detection resistance (equals 55°C for 10k NTC; B=3380)		2.9	3.5	4.2	kΩ
	Thermistor high temperature detection resistance (equals 60°C for 10k NTC; B=3380)		2.4	3	3.5	kΩ
	Thermistor high temperature detection resistance (equals 45°C for 100k NTC)		43	50	57	kΩ
	Thermistor high temperature detection resistance (equals 50°C for 100k NTC)		35	41	48	kΩ
	Thermistor high temperature detection resistance (equals 55°C for 100k NTC)		29	35	42	kΩ
	Thermistor high temperature detection resistance (equals 60°C for 100k NTC)		24	30	35	kΩ
RNTC <sub>COLD</sub>	Thermistor low temperature detection resistance (equals 0°C for 10k NTC; B=3380)	Cold temperature detected and charging suspended when the resistance of the battery-NTC is higher than RNTC <sub>COLD</sub>	25	27	30	kΩ
	Thermistor low temperature detection resistance (equals 5°C for 10k NTC; B=3380)		20	22	24	kΩ
	Thermistor low temperature detection resistance (equals 10°C for 10k NTC; B=3380)		16	18	20	kΩ
	Thermistor low temperature detection resistance (equals 15°C for 10k NTC; B=3380)		13	15	16	kΩ
	Thermistor low temperature detection resistance (equals 0°C for 100k NTC)		250	270	300	kΩ
	Thermistor low temperature detection resistance (equals 5°C for 100k NTC)		200	220	240	kΩ
	Thermistor low temperature detection resistance (equals 10°C for 100k NTC)		160	180	200	kΩ
	Thermistor low temperature detection resistance (equals 15°C for 100k NTC)		130	150	160	kΩ
V <sub>HYS(COLD)</sub>	Low temperature trip point hysteresis	For 10k NTC; B=3380		5		°C
R <sub>NOSENSOR</sub>	Thermistor not detected for 10k NTC	Hot temperature detected and charging suspended when the resistance of the battery-NTC is higher than R <sub>NOSENSOR</sub>	260	340	620	kΩ
	Thermistor not detected for 100k NTC		2500	3400	6200	kΩ
t <sub>DGL(TS)</sub>	Deglitch time, pack temperature fault detection			50		ms
<b>THERMAL REGULATION</b>						
T <sub>J(REG)</sub>	Lower Temperature regulation limit			115		°C
T <sub>J(REG)</sub>	Upper Temperature regulation limit			135		°C
T <sub>J(OFF)</sub>	Thermal shutdown temperature			155		°C
T <sub>J(OFF-HYS)</sub>	Thermal shutdown hysteresis			20		°C



DEVICE INFORMATION

Chip scale version (YFF package): PIN ASSIGNMENT (bottom view)

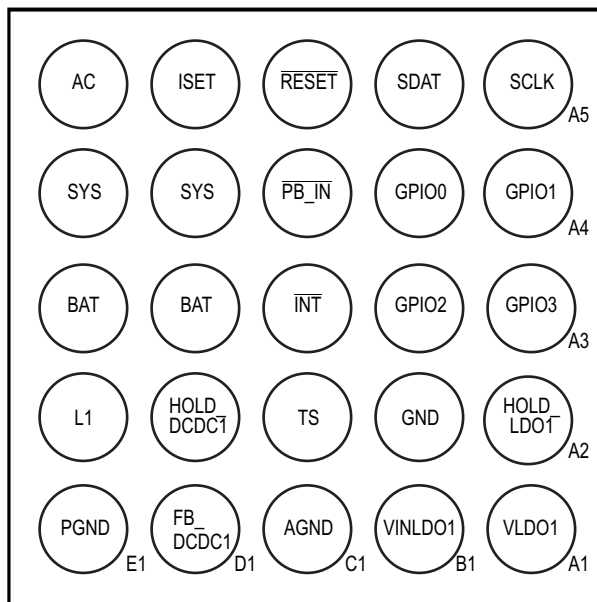

FUNCTIONAL BLOCK DIAGRAM

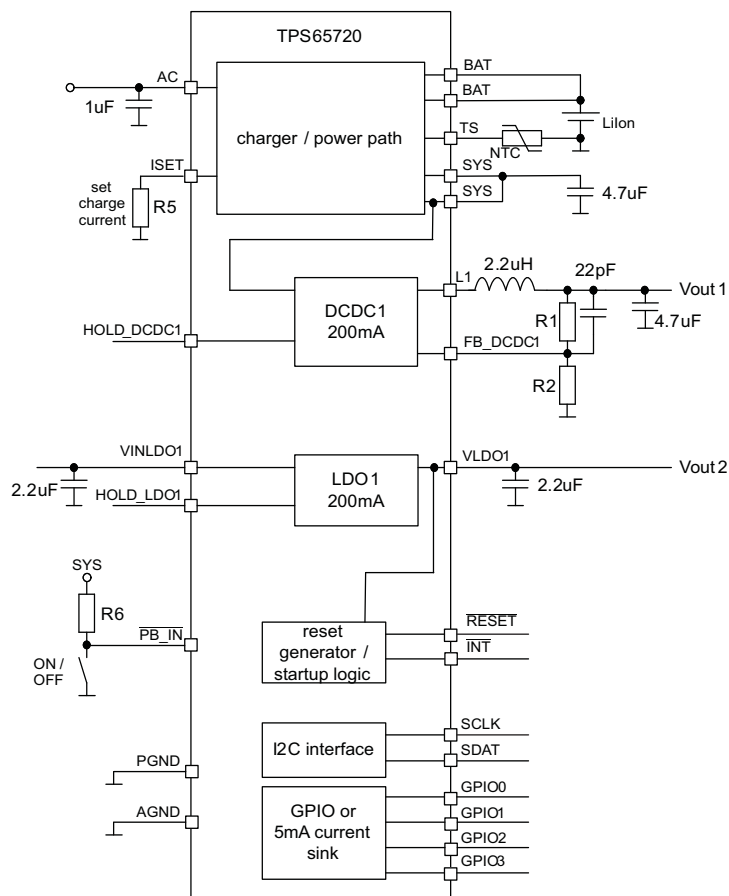

**PIN FUNCTIONS for CHIP SCALE VERSION (YFF package)**

PIN		I/O	DESCRIPTION
NAME	NO.		
AC	E5	I	Input power for power manager, connect to external DC supply.
SYS	E4, D4	O	System voltage; output of the power path manager. Power input for step-down converter DCDC1
BAT	E3, D3	I/O	Connect to battery + terminal
ISET	D5	I	Connect a resistor from this pin to GND to set fast charge current
TS	C2	I	Connect a thermistor from this pin to GND for battery temperature
AGND	C1		Analog ground
PGND	E1		Power ground
GND	B2		Connect to AGND and PGND
L1	E2	O	Switch output of step-down converter
FB_DCDC1	D1	I	Feedback input of step-down converter
HOLD_DCDC1	D2	I	Power-On input for DCDC1 converter. When pulled HIGH, the DCDC converter is kept enabled after $\overline{\text{PB\_IN}}$ was released HIGH.
VINLDO1	B1	I	Input voltage for LDO1
VLDO1	A1	O	Output voltage of LDO1
HOLD_LDO1	A2	I	Power-On input for LDO1. When pulled HIGH, LDO1 is kept enabled after $\overline{\text{PB\_IN}}$ was released HIGH.
SDAT	B5	I/O	Data line for the I2C interface
SCLK	A5	I	Clock input for the I2C interface
$\overline{\text{PB\_IN}}$	C4	I	Push button input; Turns on DCDC1 and LDO1 if pulled to GND.
$\overline{\text{INT}}$	C3	O	Open drain interrupt output
$\overline{\text{RESET}}$	C5	O	Open drain output of the reset generator; This output goes active LOW when the output voltage of LDO1 falls 8% below its target voltage.
GPIO0	B4	I/O	General purpose I/O
GPIO1	A4	I/O	General purpose I/O
GPIO2	B3	I/O	General purpose I/O or 5mA current sink
GPIO3	A3	I/O	General purpose I/O or 5mA current sink

**QFN version (RSN package): PIN ASSIGNMENT (top view)**

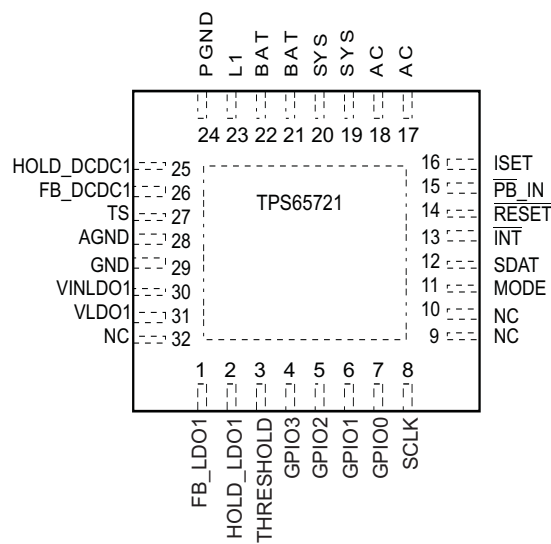

FUNCTIONAL BLOCK DIAGRAM

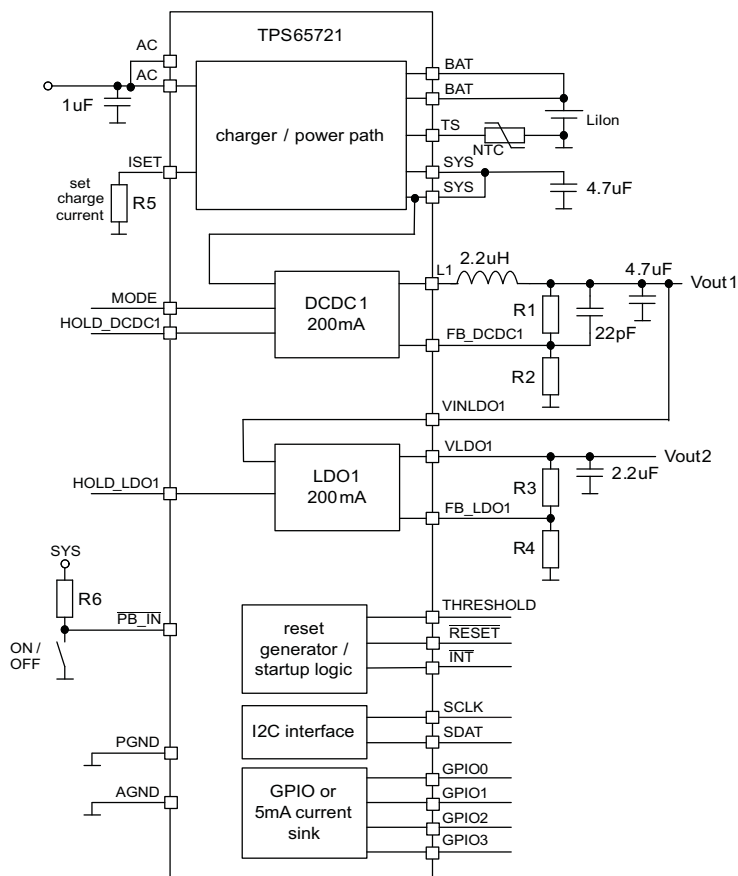

PIN FUNCTIONS for QFN VERSION (RSN package)

PIN		I/O	DESCRIPTION
NAME	NO.		
AC	17, 18	I	Input power for power manager, connect to external DC supply.
SYS	19, 20	O	System voltage; output of the power path manager. Power input for step-down converter DCDC1
BAT	21, 22	I/O	Connect to battery + terminal
ISET	16	I	Connect a resistor from this pin to GND to set fast charge current
TS	27	I	Connect a thermistor from this pin to GND for battery temperature
AGND	28		Analog ground
PGND	24		Power ground
L1	23	O	Switch output of step-down converter
FB_DCDC1	26	I	Feedback input of step-down converter
HOLD_DCDC1	25	I	Power-On input for DCDC1 converter. When pulled HIGH, the DCDC converter is kept enabled after $\overline{\text{PB\_IN}}$ was released HIGH.
VINLDO1	30	I	Input voltage for LDO1
VLDO1	31	O	Output voltage from LDO1
FB_LDO1	1	I	Feedback input for LDO1
HOLD_LDO1	2	I	Power-On input for LDO1. When pulled HIGH, LDO1 is kept enabled after $\overline{\text{PB\_IN}}$ was released HIGH.
SDAT	12	I/O	Data line for the I2C interface
SCLK	8	I	Clock input for the I2C interface
$\overline{\text{PB\_IN}}$	15	I	Push button input; Turns on DCDC1 and LDO1 if pulled to GND.
$\overline{\text{INT}}$	13	O	Open drain interrupt output

**PIN FUNCTIONS for QFN VERSION (RSN package) (continued)**

PIN		I/O	DESCRIPTION
NAME	NO.		
RESET	14	O	Open drain output of the reset generator; This output goes active LOW when the input voltage at pin THRESHOLD falls below the threshold voltage.
THRESHOLD	3	I	Input voltage to the reset comparator. When the input voltage falls below the threshold, the RESET output is actively pulled LOW.
GPIO0	7	I/O	General purpose I/O
GPIO1	6	I/O	General purpose I/O
GPIO2	5	I/O	General purpose I/O or 5mA current source
GPIO3	4	I/O	General purpose I/O or 5mA current source
MODE	11	I	Pull HIGH to force the DCDC1 converter to PWM mode.
GND	29	–	Connect to AGND and PGND
PowerPad	–		Connect to GND

**PARAMETER MEASUREMENT INFORMATION**

**Setup**

The graphs have been generated on the TPS65720YFF EVM with the inductors as mentioned in the graphs. See the TPS65720 EVM users guide (SLVU324) for details on the layout.

**TYPICAL CHARACTERISTICS**

**TABLE OF GRAPHS**

			FIGURE
	TPS65720: Efficiency DCDC1 vs Load current / PWM mode 200mA; L= Murata LQM21P 3.3 $\mu$ H	Vo = 2.05V; Vi = 3.0V, 3.6V, 4.2V, 5.0V	<a href="#">Figure 1</a>
	TPS65720: Efficiency DCDC1 vs Load current / PFM mode 200mA; L= Murata LQM21P 3.3 $\mu$ H	Vo = 2.05V; Vi = 3.0V, 3.6V, 4.2V, 5.0V	<a href="#">Figure 2</a>
	TPS65720: Efficiency DCDC1 vs Load current / PWM mode 200mA; L= FDK MIPS2520 2.2 $\mu$ H	Vo = 2.05V; Vi = 3.0V, 3.6V, 4.2V, 5.0V	<a href="#">Figure 3</a>
	TPS65720: Efficiency DCDC1 vs Load current / PFM mode 200mA; L= FDK MIPS2520 2.2 $\mu$ H	Vo = 2.05V; Vi = 3.0V, 3.6V, 4.2V, 5.0V	<a href="#">Figure 4</a>
	TPS65721: Efficiency DCDC1 vs Load current / PWM mode; L= FDK MIPS2520 2.2 $\mu$ H	Vo = 3.3V; Vi = 3.0V, 3.6V, 4.2V, 5.0V	<a href="#">Figure 5</a>
	TPS65721: Efficiency DCDC1 vs Load current / PFM mode 500mA; L= FDK MIPS2520 2.2 $\mu$ H	Vo = 3.3V; Vi = 3.0V, 3.6V, 4.2V, 5.0V	<a href="#">Figure 6</a>
	TPS65721: Efficiency DCDC1 vs Load current / PWM mode; L= FDK MIPS2520 2.2 $\mu$ H	Vo = 1.8V; Vi = 3.0V, 3.6V, 4.2V, 5.0V	<a href="#">Figure 7</a>
	TPS65721: Efficiency DCDC1 vs Load current / PFM mode 500mA; L= FDK MIPS2520 2.2 $\mu$ H	Vo = 1.8V; Vi = 3.0V, 3.6V, 4.2V, 5.0V	<a href="#">Figure 8</a>
	Load transient response DCDC1; L= FDK MIPS2520 2.2 $\mu$ H, PFM mode	Scope plot Io = 20mA to 180mA; Vo = 2.05V; Vi = 3.6V	<a href="#">Figure 9</a>
	Load transient response DCDC1; L =FDK MIPS2520 2.2 $\mu$ H, PWM mode	Scope plot Io = 50 $\mu$ A to 60mA; Vo = 2.05V; Vi = 3.6V	<a href="#">Figure 10</a>
	Load transient response DCDC1; L= FDK MIPS2520 2.2 $\mu$ H, PWM mode	Scope plot Io = 40mA to 360mA; Vo = 3.3V; Vi = 3.6V	<a href="#">Figure 11</a>
	Line transient response DCDC1; L= FDK MIPS2520 2.2 $\mu$ H, PWM mode	Scope plot; Vo = 2.05V Vi = 3.6V to 5V to 3.6V; Io = 60mA	<a href="#">Figure 12</a>
	Output voltage ripple in PFM mode; DCDC1	Scope plot: Vi = 3.6V Vo = 2.05V; Io = 50 $\mu$ A (PFM); Io = 60mA (PWM)	<a href="#">Figure 13</a>

TYPICAL CHARACTERISTICS (continued)

		FIGURE
Output voltage ripple in PWM mode; DCDC1	Scope plot: $V_i = 3.6V$ $V_o = 2.05V$ ; $I_o = 60mA$ (PWM)	Figure 14
Startup DCDC1 and LDO1	Scope plot using TPS65720 (battery powered) for /PB_IN; $V_o_{DCDC1}$ ; $V_o_{LDO1}$	Figure 15
Load transient response LDO1	Scope plot; $V = 1.85V$ ; $V_i = 2.05V$ $I = 50 \mu A$ to $60mA$ to $50 \mu A$	Figure 16
Line transient response LDO1	Scope plot; $V_o = 1.85V$ ; $V_i = 5V$ to $3.6V$ to $5V$	Figure 17
Kset vs Riset		Figure 18–Figure 21
Efficiency vs $I_{out}$ for DCDC1=2.05V, LDO1=1.85V, $V_{inLDO}=V_{DCDC1}$		Figure 22

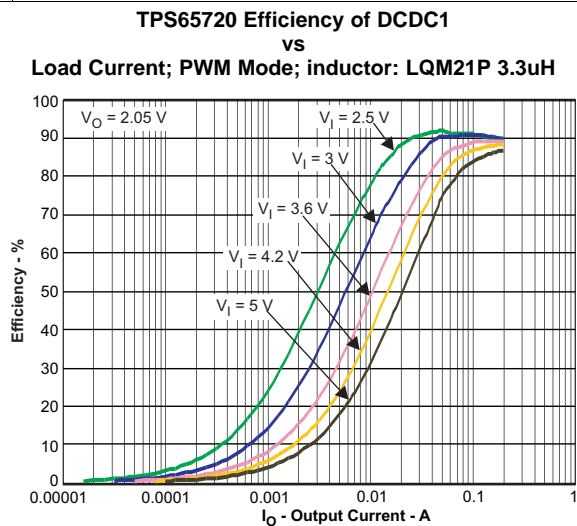

Figure 1.

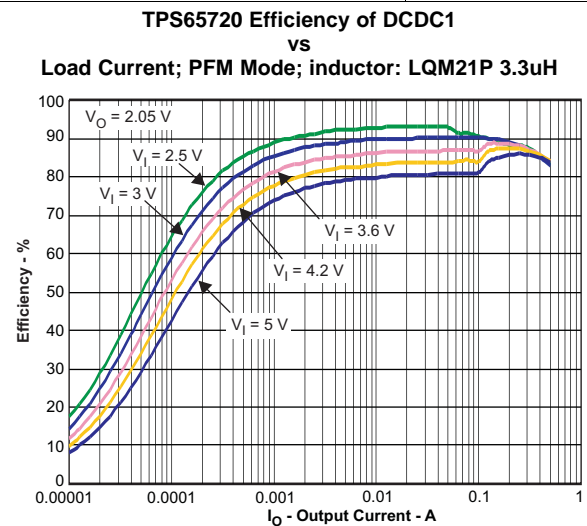

Figure 2.

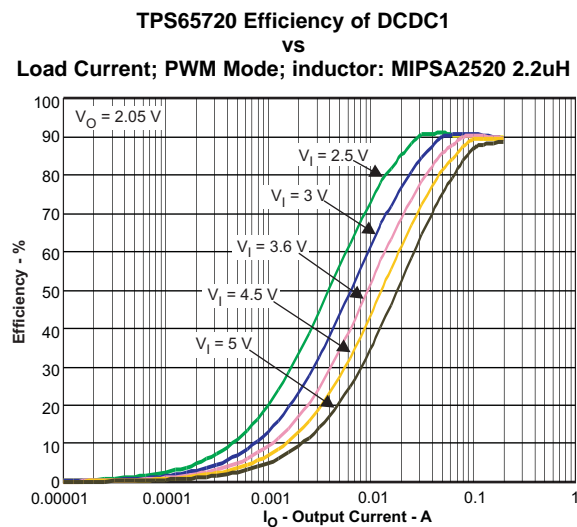

Figure 3.

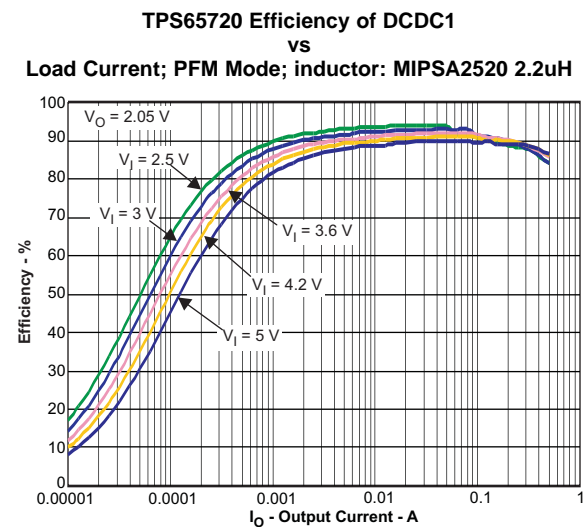

Figure 4.

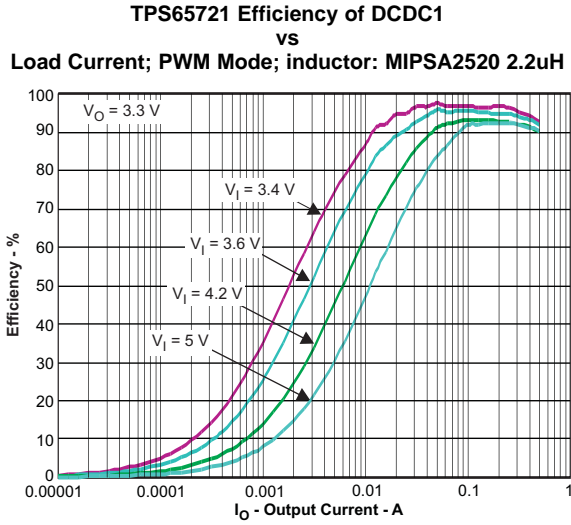

Figure 5.

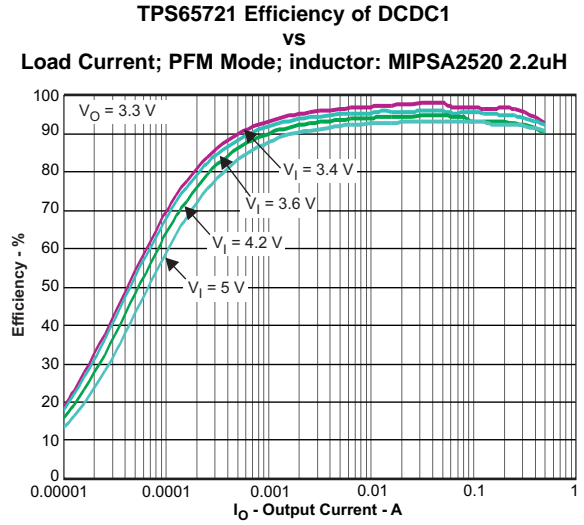

Figure 6.

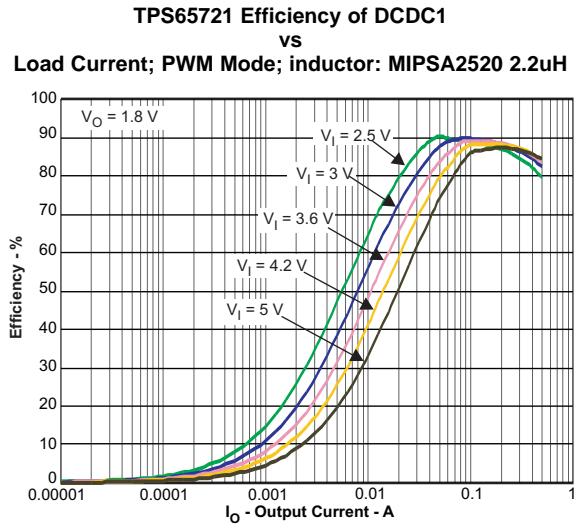

Figure 7.

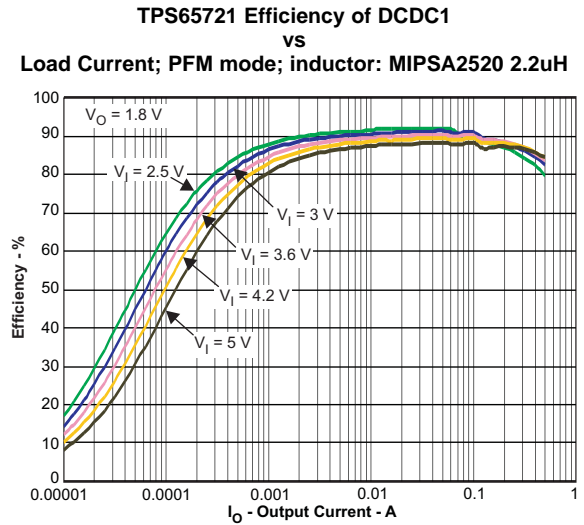

Figure 8.

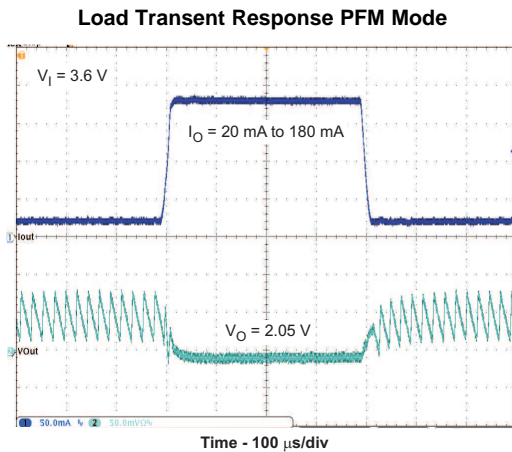

Figure 9.

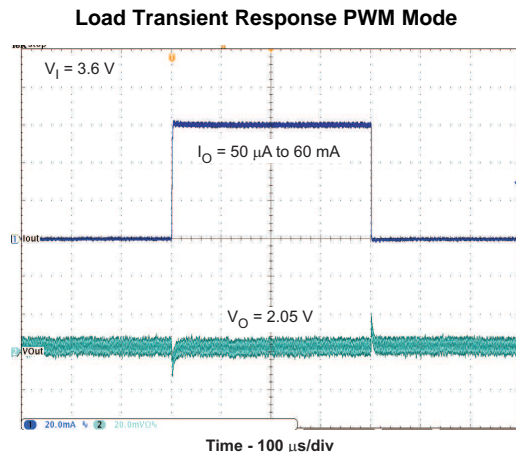

Figure 10.

Load Transient Response PWM Mode

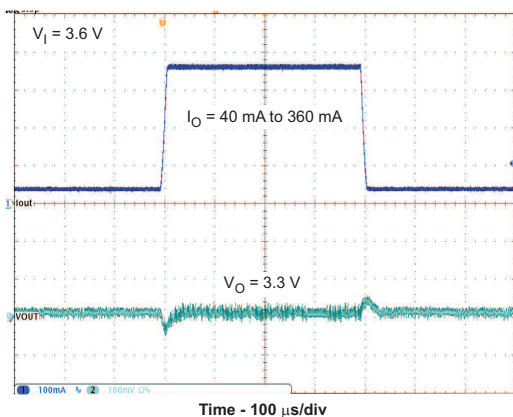

Figure 11.

Line Transient Response PWM Mode

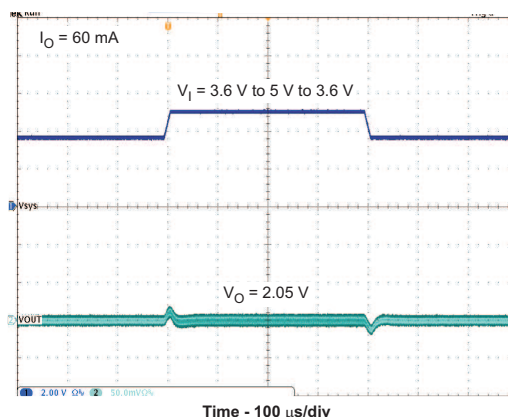

Figure 12.

Output Voltage Ripple on DCDC1  
PFM Mode

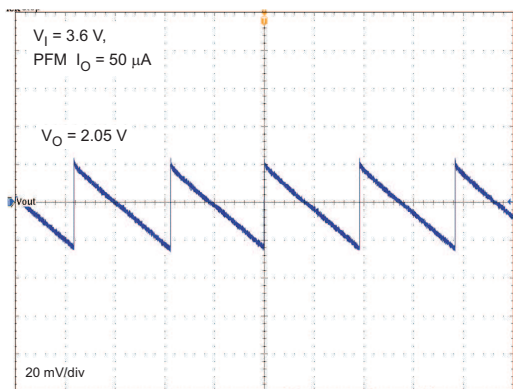

Figure 13.

Output Voltage Ripple on DCDC1  
PWM Mode

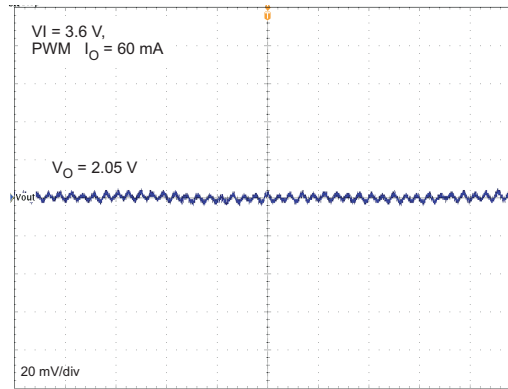

Figure 14.

Startup DCDC1 and LDO1

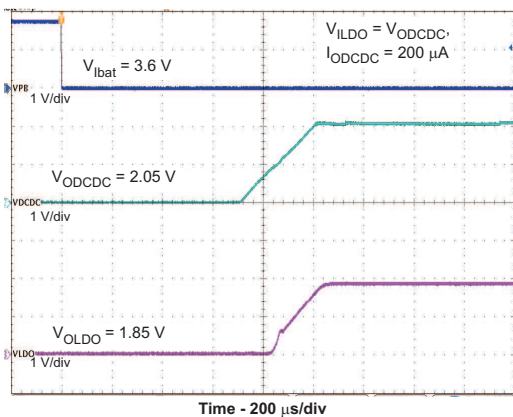

Figure 15.

Load Transient Response LDO1

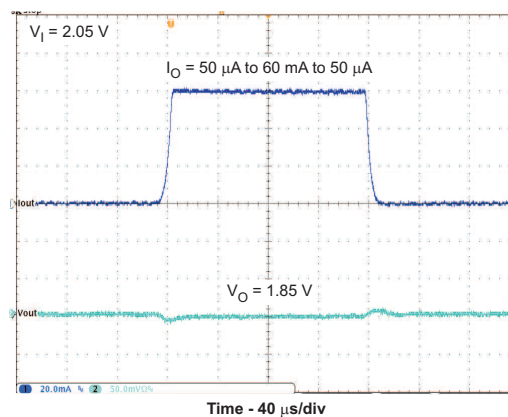

Figure 16.

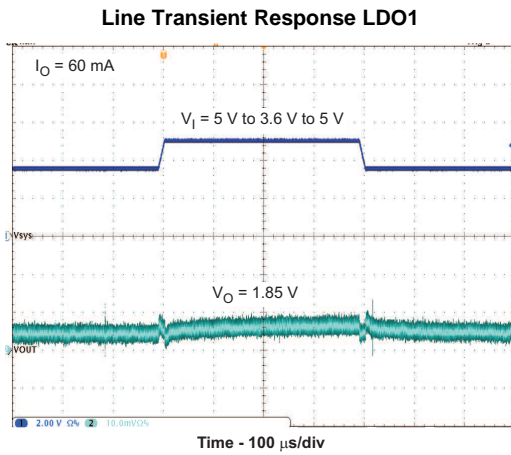

Figure 17.

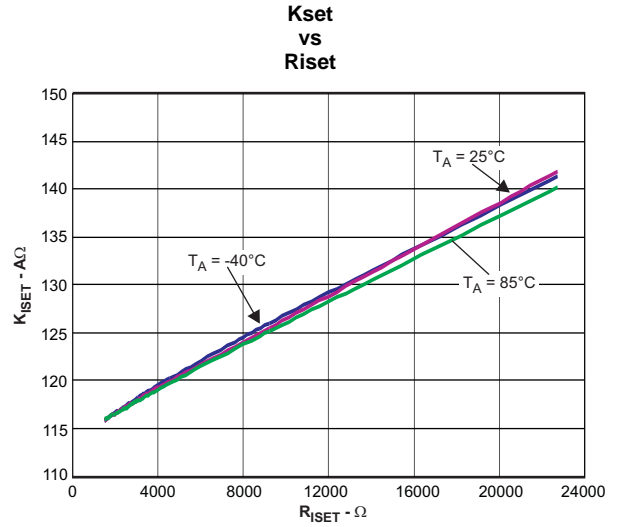

Figure 18. ICH\_SCL[1,0]=00

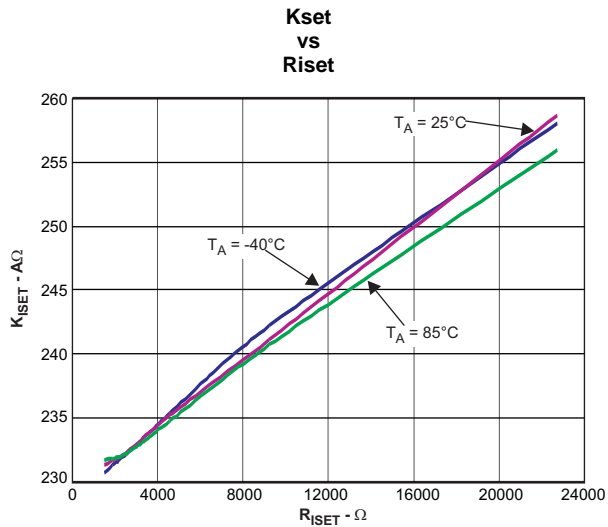

Figure 19. ICH\_SCL[1,0]=01

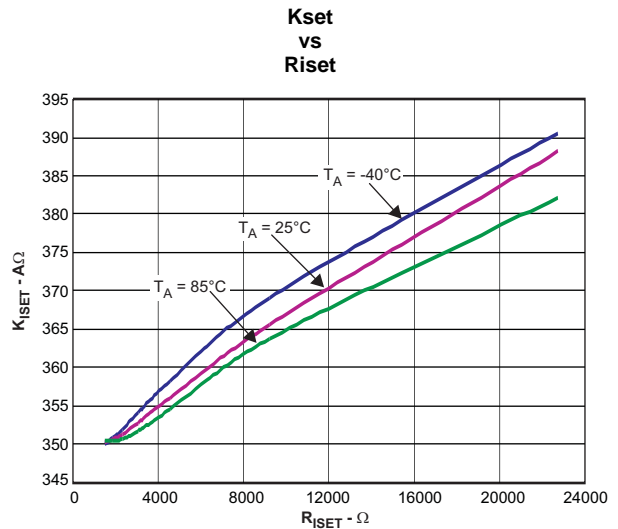

Figure 20. ICH\_SCL[1,0]=10



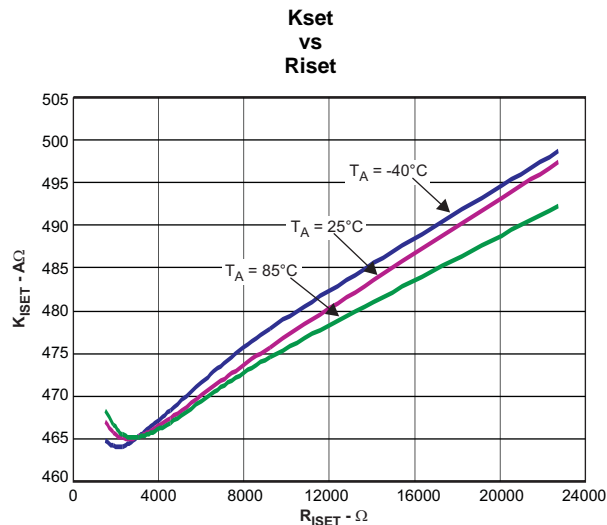

Figure 21. ICH\_SCL[1,0]=11

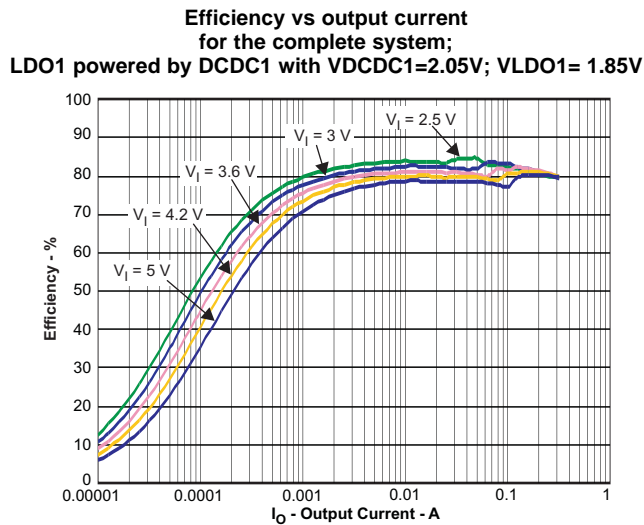

Figure 22.

## DETAILED DESCRIPTION

### BATTERY CHARGER AND POWER PATH

The TPS65720 integrates a Li-Ion linear charger and system power path management targeted at space-limited portable applications. The TPS65720 powers the system while simultaneously and independently charging the battery. This feature reduces the number of charge and discharge cycles on the battery, allows for proper charge termination and enables the system to run with a defective or absent battery pack. It also allows instant system turn-on even with a totally discharged battery. The input power source for charging the battery and running the system can be an AC adapter or an USB port. The power-path management feature automatically reduces the charging current if the system load increases. The power-path architecture also permits the battery to supplement the system current requirements when the adapter cannot deliver the peak system currents.

### POWER DOWN

The charger remains in power-down mode when the input voltage at the AC pin is below the under-voltage lockout threshold (UVLO). During the power-down mode, the host commands through the I<sup>2</sup>C interface are ignored. The Q1 FET connected between AC and SYS pins is off. The Q2 FET that connects BAT to SYS is ON.

(If <SYSOFF>=1, Q2 is off). During power-down mode, the V<sub>OUT(SC2)</sub> circuitry is active and monitors for overload conditions on SYS.

### SLEEP MODE

The charger enters sleep mode when V<sub>AC</sub> is greater than UVLO, but below V<sub>BAT</sub> + V<sub>IN(DT)</sub>. In sleep mode, the host commands are ignored. The Q1 FET connected between AC and SYS pins is off. The Q2 FET that connects BAT to SYS is ON. (If <SYSOFF>=1, Q2 is off). During sleep mode, the V<sub>OUT(SC2)</sub> circuitry is active and monitors for overload conditions on SYS.

### STANDBY MODE

When V<sub>AC</sub> is greater than UVLO and V<sub>IN</sub> is greater than V<sub>BAT</sub> + V<sub>IN(DT)</sub>, the device is in standby mode. <CH\_PGOOD> =1 to indicate the valid power status and the host commands are read. The device enters standby mode whenever <AC input current1, AC input current0> = (0,0) or if an input overvoltage condition occurs. In standby mode, Q1 is OFF and Q2 is ON. (If <SYSOFF>=1, Q2 is off). During standby mode, the V<sub>OUT(SC2)</sub> circuitry is active and monitors for overload conditions on SYS.

## POWER-ON RESET MODE

The charger enters power-on reset mode when the input voltage at AC is within the valid range:  $V_{AC} > UVLO$  and  $V_{AC} > V_{BAT} + V_{IN(DT)}$  and  $V_{AC} < VOVP$ , and the Bits <AC input current1, AC input current0> indicate that the USB suspend mode is not enabled [ $\langle AC \text{ input current1, AC input current0} \rangle \neq (0,0)$ ]. During power-on reset mode, all internal timers and other circuit blocks are activated. The device checks for short-circuits at the ISET pin. If no short conditions exists, the device switches on the input FET Q1 with a 100-mA current limit to check for a short circuit at SYS. If VOUT rises above VSC, the FET Q1 switches to the current-limit threshold set by  $\langle AC \text{ input current1, AC input current0} \rangle$ , and the device enters into the Idle mode.

## IDLE MODE

In the Idle mode, the system is powered by the input source (Q1 is on), and the device continuously monitors the status of the host commands. It also continuously monitors the input voltage conditions. Q2 is turned on whenever the input source cannot deliver the required load current (supplement mode). The device also enters Idle mode whenever  $\langle CH\_EN \rangle = 0$  while the input voltage is in the valid range of operation.

## POWER-PATH MANAGEMENT

The current at the input pin AC of the power path manager is shared between charging the battery and powering the system load on the SYS pin. Priority is given to the system load. The input current is monitored continuously. If the sum of the charging and system load currents exceeds the preset maximum input current (programmed internally by I2C), the charging current is reduced automatically. The default value for the current limit is 500mA for the AC pin.

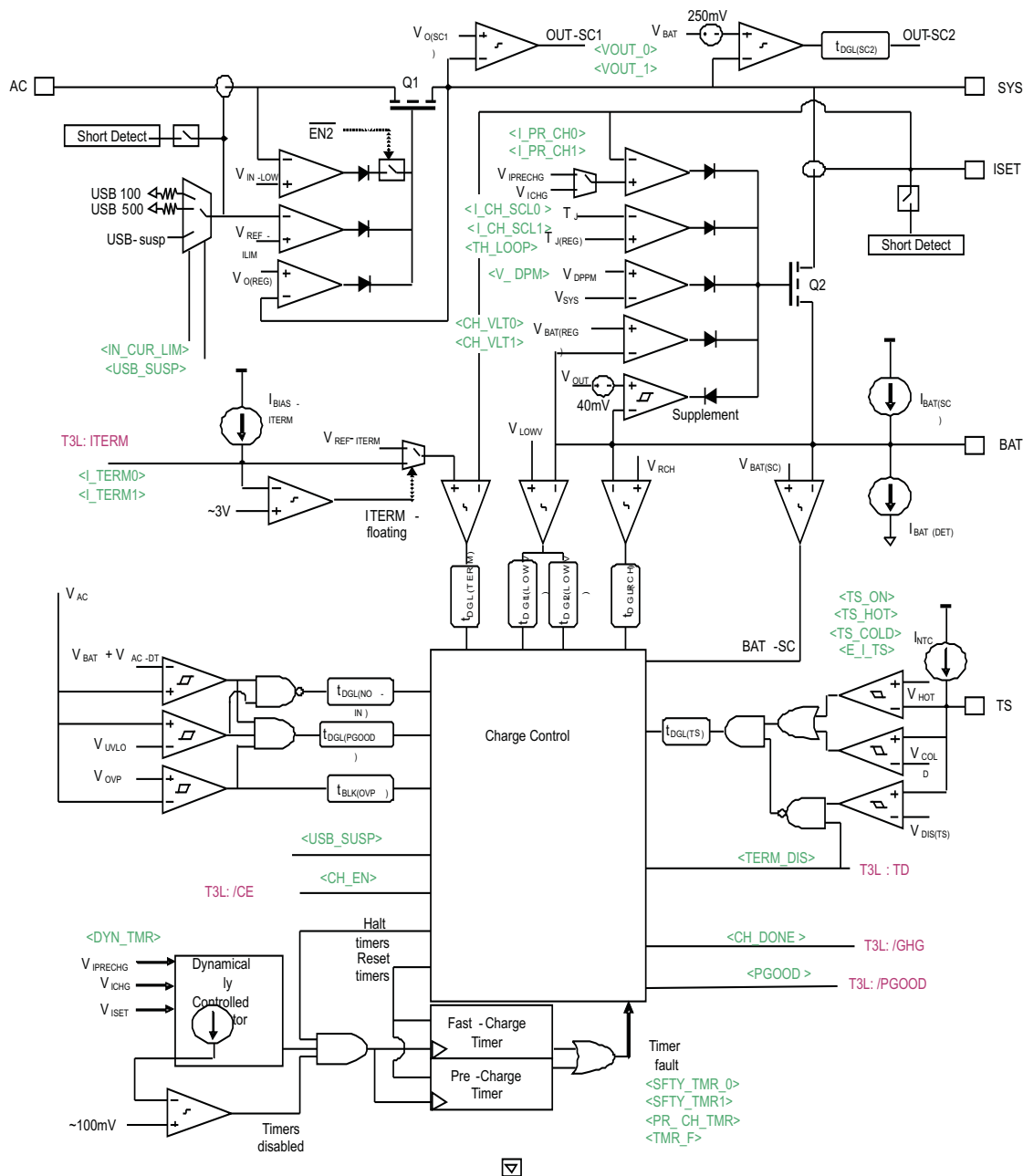

Figure 23. Charger Block Diagram

### BATTERY CHARGING

When  $\langle CH\_EN \rangle = 1$ , battery charging begins. First, the device checks for a short circuit on the BAT pin by sourcing  $I_{BAT(SC)}$  to the battery and monitoring the voltage. When the BAT voltage exceeds  $V_{BAT(SC)}$ , the battery charging continues. The battery is charged in three phases: conditioning precharge, constant-current fast charge (current regulation) and a constant-voltage tapering (voltage regulation). In all charge phases, an internal control loop monitors the IC junction temperature and reduces the charge current if an internal temperature threshold is exceeded.

Figure 24 shows what happens in each of the three phases:

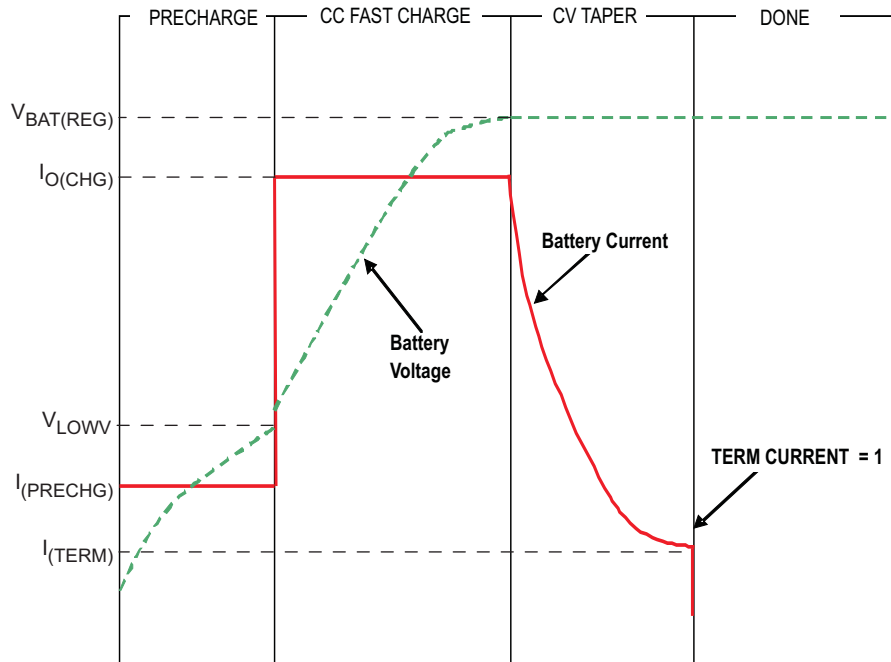

Figure 24. Battery Charge

In the precharge phase, the battery is charged with the precharge current ( $I_{PRECHG}$ ). Once the battery voltage crosses the  $V_{LOWV}$  threshold, the battery is charged with the fast-charge current ( $I_{CHG}$ ). As the battery voltage reaches  $V_{BAT(REG)}$ , the battery is held at a constant voltage of  $V_{BAT(REG)}$  and the charge current tapers off as the battery approaches full charge. When the battery current reaches  $I_{TERM}$ , the CHG pin indicates *charging done* by going high impedance. Note that termination detection is disabled whenever the charge rate is reduced from the set point because of the actions of the thermal loop, the DPM loop, or the  $V_{IN}(LOW)$  loop. The value of the fast-charge current is set by the resistor connected from the ISET pin to GND, and is given by the equation:

$$I_{CHG} = K_{ISET}/R_{ISET}$$

The charge current limit is adjustable up to 300mA. The valid resistor range is 1500 $\Omega$  to 11.25k $\Omega$ . Note that if  $I_{CHG}$  is programmed as greater than the input current limit, the battery does not charge at the rate of  $I_{CHG}$ , but at the slower rate of  $I_{ACmax}$  (minus the load current on the OUT pin, if any). In this case, the charger timers are proportionately slowed down.

### I-PRECHARGE

The value for the pre-charge current is defined with Bits  $\langle I\_PRE1, I\_PRE0 \rangle$  based on the charge current defined with pin ISET and Bits  $\langle CH\_SCL1, ICH\_SCL0 \rangle$  in register CHCONFIG1. Pre-charge current is scaled to lower currents in DPPM mode or when the charger is in thermal regulation.

### I\_TERM

The value for the termination current threshold can be set in register CHGCONFIG1 using Bits  $\langle I\_TERM1, I\_TERM0 \rangle$  based on the charge current defined with pin ISET and Bits  $\langle CH\_SCL1, ICH\_SCL0 \rangle$ . Termination current is not scaled in DPPM mode or when the charger is in thermal regulation.

### BATTERY DETECTION AND RECHARGE

The charger automatically detects if a battery is connected or removed. Once a charge cycle is complete, the battery voltage is monitored. When the battery voltage falls below  $V_{RCH}$ , the device determines if the battery has been removed. A current,  $I_{BAT(DET)}$ , is pulled from the battery for a duration  $t_{DET}$ . If the voltage on the BAT pin remains above  $V_{LOWV}$ , it indicates that the battery is still connected, but has discharged. If  $\langle CH\_EN \rangle = 1$ , the charger is turned on again to top off the battery. During this recharge cycle, the CHG output remains high-impedance. Recharge cycles are not indicated by the  $\langle CH\_ACTIVE \rangle$  Bit.

If the BAT voltage falls below  $V_{LOWV}$  during the battery detection test, it indicates that the battery has been removed. The device then checks for battery insertion. The FET Q2 is turned on and sources  $I_{PRECHG}$  out of BAT for the duration of  $t_{DET}$ . If the battery voltage does not rise above  $V_{RCH}$ , it indicates that a battery has been inserted, and a new charge cycle begins. If the voltage rises above  $V_{RCH}$ , it is possible that a fully charged battery has been inserted. To check for this,  $I_{BAT(DET)}$  is pulled from the battery for  $t_{DET}$ . If the voltage falls below  $V_{LOWV}$ , a battery is not present. The device continuously checks for the presence of a battery.

### CHARGE TERMINATION ON/OFF

Charge termination can be disabled by setting the Bit  $\langle TERM\_EN \rangle = 0$ . When termination is disabled, the device goes through the pre-charge, fast-charge, and CV phases, then remains in the CV phase. During the CV phase, the charger behaves like an LDO with an output voltage equal to  $V_{BAT(REG)}$  and is able to source currents up to  $I_{CHG}$  or  $I_{INmax}$ , whichever is less. Battery detection is not performed. The Bit  $\langle CH\_ACTIVE \rangle = 0$  once the current falls below  $I_{TERM}$  and does not go to 1 until the input power is toggled. When termination is disabled, the pre-charge and fast-charge safety timers are also disabled. Battery pack temperature sensing (TS pin functionality) is also disabled if Bit  $\langle TERM\_EN \rangle = 0$  and the TS pin is unconnected.

### TIMERS

The charger in TPS65720 has internal safety timers for the pre-charge and fast-charge phases to prevent potential damage to either the battery or the system. The default values for the timers can be changed in register CHGCONFIG2.

The pre-charge timer and fast charge timer will run with their nominal speed defined in register CHCONFIG2 if  $ICH\_SCL[1,0] = 01$ , which equals a charge current of 50% defined with the ISET resistor. If  $ICH\_SCL[1,0]$  are set to higher or lower fast-charge current, the fast charge timers and pre-charge timers are scaled automatically. For instance, with  $ICH\_SCL[1,0] = 11$ , which equals 100% of fast charge current, the safety timers will time out in half the time defined in register CHCONFIG2. Changing the pre-charge current with  $I\_PRE[1,0]$  will not change the pre-charge or fast-charge timers.

### DYNAMIC TIMER FUNCTION

During the fast-charge phase, several events increase the timer durations.

1. The system load current activates the DPM loop which reduces the available charging current
2. The input current is reduced because the input voltage has fallen to  $V_{IN(LOW)}$
3. The device has entered thermal regulation because the IC junction temperature has exceeded  $T_{J(REG)}$

During each of these events, the internal timers are slowed down proportionately to the reduction in charging current. For example, if the charging current is reduced by half, the fast-charge timer is twice as long as programmed.

A modified charge cycle with the thermal loop active is shown in [Figure 25](#)

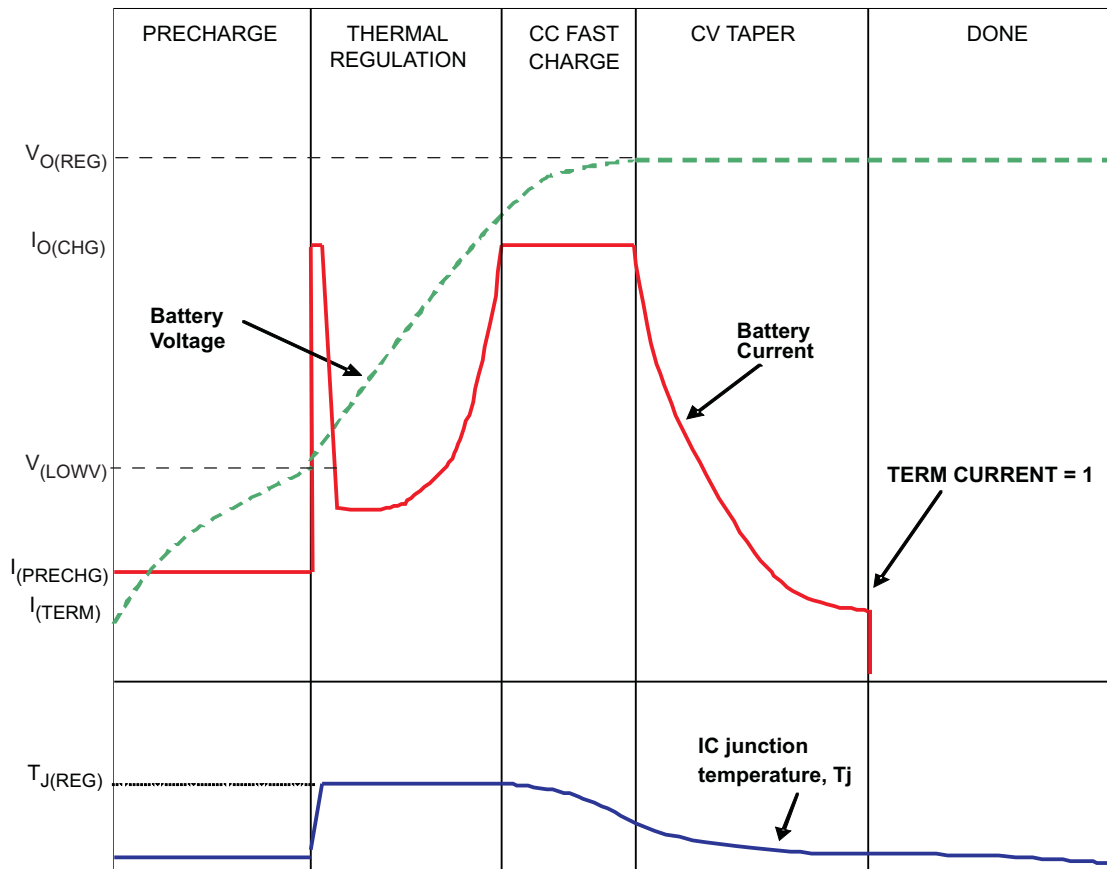

Figure 25. Thermal Loop

## TIMER FAULT

If the pre-charge timer expires before the battery voltage reaches  $V_{LOWV}$ , the charger indicates a fault condition. Additionally, if the battery current does not fall to  $I_{TERM}$  before the fast-charge timer expires, a fault is indicated by setting Bit  $\langle \text{TIMER\_FAULT} \rangle = 1$ .

## THERMAL REGULATION AND THERMAL SHUTDOWN

The charger contains a thermal regulation loop that monitors the die temperature. If the temperature exceeds  $T_{J(REG)}$ , the device automatically reduces the charging current to prevent the die temperature from increasing further. In some cases, the die temperature continues to rise despite the operation of the thermal loop, particularly under high VAC and heavy system load conditions. Under these conditions, if the die temperature increases to  $T_{J(OFF)}$ , the input FET Q1 is turned OFF. FET Q2 is turned ON to ensure that the battery still powers the load on SYS. Once the device die temperature cools by  $T_{J(OFF-HYS)}$ , the input FET Q1 is turned on and the device returns to thermal regulation. Continuous over-temperature conditions result in the pulsing of the Q1 FET. Note that this feature monitors the die temperature of the charger. This is not synonymous with ambient temperature. Self-heating exists due to the power dissipated in the IC because of the linear nature of the battery charging algorithm and the LDO mode for SYS.

## BATTERY PACK TEMPERATURE MONITORING

The TPS65720 features an external battery pack temperature monitoring input. The TS input connects to the NTC resistor in the battery pack to monitor battery temperature and prevent dangerous over-temperature conditions. During charging,  $I_{NTC}$  is sourced to TS and the voltage at TS is continuously monitored. If, at any time, the voltage at TS is outside of the operating range ( $V_{COLD}$  to  $V_{HOT}$ ), charging is suspended. The timers maintain their values but suspend counting. When the voltage measured at TS returns to within the operation

window, charging is resumed and the timers continue counting. When charging is suspended due to a battery pack temperature fault, the CH\_ACTIVE Bit remains 1 and continues to indicate *charging*. Battery pack temperature sensing is disabled when termination is disabled (<TERM\_EN=0>) and the voltage at TS is greater than  $V_{DIS(TS)}$ . The battery pack temperature monitoring is disabled by connecting a 10-k $\Omega$  resistor from TS to GND.

TPS65720 contains a feature to shift the termination temperature to higher levels by setting Bits <TMP\_SHIFT1, TMP\_SHIFT0>.

## DCDC1 CONVERTER

The TPS65720 step down converter operates with typically 2.25 MHz fixed frequency pulse width modulation (PWM) at moderate to heavy load currents. At light load currents the converter can automatically enter Power Save Mode and operates then in PFM mode.

During PWM operation the converter use a unique fast response voltage mode control scheme with input voltage feed-forward to achieve good line and load regulation allowing the use of small ceramic input and output capacitors. At the beginning of each clock cycle initiated by the clock signal, the High Side MOSFET switch is turned on. The current flows now from the input capacitor via the High Side MOSFET switch through the inductor to the output capacitor and load. During this phase, the current ramps up until the PWM comparator trips and the control logic will turn off the switch. The current limit comparator will also turn off the switch in case the current limit of the High Side MOSFET switch is exceeded. After a dead time preventing shoot through current, the Low Side MOSFET rectifier is turned on and the inductor current will ramp down. The current flows now from the inductor to the output capacitor and to the load. It returns back to the inductor through the Low Side MOSFET rectifier.

The next cycle will be initiated by the clock signal again turning off the Low Side MOSFET rectifier and turning on the on the High Side MOSFET switch.

The DCDC1 converters output voltage is externally adjustable using a resistor divider at FB\_DCDC1.

## POWER SAVE MODE

The Power Save Mode is enabled automatically with <F\_PWM>=0 which is the default setting. If the load current decreases, the converter will enter Power Save Mode operation automatically. During Power Save Mode the converter skips switching and operates with reduced frequency in PFM mode with a minimum quiescent current to maintain high efficiency. The converter will position the output voltage typically +1% above the nominal output voltage. This voltage positioning feature minimizes voltage drops caused by a sudden load step. The transition from PWM mode to PFM mode occurs once the inductor current in the Low Side MOSFET switch becomes zero, which indicates discontinuous conduction mode. During the Power Save Mode the output voltage is monitored with a PFM comparator. As the output voltage falls below the PFM comparator threshold of VOUT nominal +1%, the device starts a PFM current pulse. The High Side MOSFET switch will turn on, and the inductor current ramps up. After the On-time expires, the switch is turned off and the Low Side MOSFET switch is turned on until the inductor current becomes zero. The converter effectively delivers a current to the output capacitor and the load. If the load is below the delivered current, the output voltage will rise. If the output voltage is equal or higher than the PFM comparator threshold, the device stops switching and enters a sleep mode with typical 15 $\mu$ A current consumption.

If the output voltage is still below the PFM comparator threshold, a sequence of further PFM current pulses are generated until the PFM comparator threshold is reached. The converter starts switching again once the output voltage drops below the PFM comparator threshold. With a fast single threshold comparator, the output voltage ripple during PFM mode operation can be kept small. The PFM Pulse is time controlled, which allows to modify the charge transferred to the output capacitor by the value of the inductor. The resulting PFM output voltage ripple and PFM frequency depend in first order on the size of the output capacitor and the inductor value. Increasing output capacitor values and inductor values will minimize the output ripple. The PFM frequency decreases with smaller inductor values and increases with larger values. The PFM mode is left and PWM mode is entered in case the output current can not longer be supported in PFM mode. The Power Save Mode can be disabled by setting <F\_PWM>=1. The converter will then operate in fixed frequency PWM mode.

## Dynamic Voltage Positioning

This feature reduces the voltage under/overshoots at load steps from light to heavy load and vice versa. It is active in Power Save Mode and regulates the output voltage 1% higher than the nominal value. This provides more headroom for both the voltage drop at a load step, and the voltage increase at a load throw-off.

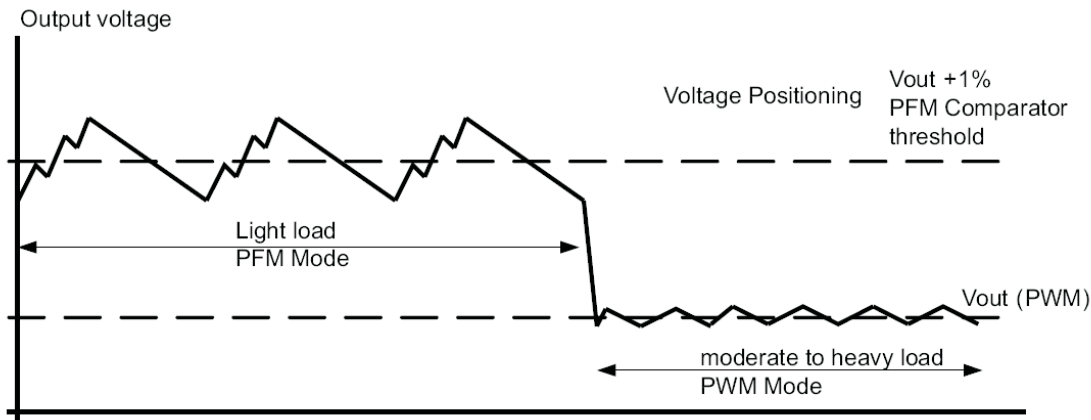

## Soft Start

The step-down converter in TPS65720 has an internal soft start circuit that controls the ramp up of the output voltage. The output voltage ramps up from 5% to 95% of its nominal value within typical 250µs. This limits the inrush current in the converter during ramp up and prevents possible input voltage drops when a battery or high impedance power source is used.

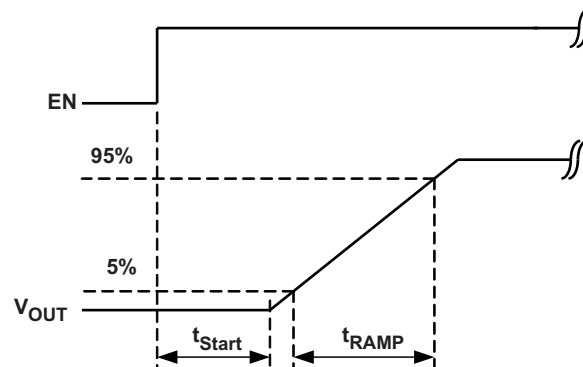

Figure 26. Soft Start

## 100% Duty Cycle Low Dropout Operation

The device starts to enter 100% duty cycle mode once the input voltage comes close to the nominal output voltage. In order to maintain the output voltage, the High Side MOSFET switch is turned on 100% for one or more cycles. With further decreasing  $V_{IN}$  the High Side MOSFET switch is turned on completely. In this case the converter offers a low input-to-output voltage difference. This is particularly useful in battery-powered applications to achieve longest operation time by taking full advantage of the whole battery voltage range. The minimum input voltage to maintain regulation depends on the load current and output voltage, and can be calculated as:

$$V_{INmin} = V_{Omax} + I_{Omax} \times (R_{DS(on)max} + R_L)$$

With:

$I_{Omax}$  = maximum output current plus inductor ripple current

$R_{DS(on)max}$  = maximum high side switch  $R_{DS(on)}$ .

$R_L$  = DC resistance of the inductor

$V_{Omax}$  = nominal output voltage plus maximum output voltage tolerance



## Under-Voltage Lockout

The under voltage lockout circuit prevents the device from malfunctioning at low input voltages and from excessive discharge of the battery and disables the converters and LDOs. The under-voltage lockout threshold is typically 2.2V.

## SHORT-CIRCUIT PROTECTION

All outputs are short circuit protected with a maximum output current as defined in the electrical specifications.

## THERMAL SHUTDOWN

There are two thermal sensors in TPS6572x located at the main sources of power dissipation - the charger and the LDO. The maximum temperature of the charger is regulated by reducing its charge current. If the temperature increases further, the charger is disabled - see details in the charger description.

The second sensor is enabled as soon as the LDO is enabled. As soon as the junction temperature,  $T_J$ , exceeds typically 150°C, the device goes into thermal shutdown. In this mode, the low side and high side MOSFETs are turned-off. A thermal shutdown for the LDO will disable both, LDO and the DCDC converter simultaneously.

## LDO1

The low dropout voltage regulator is designed to operate well with low value ceramic input and output capacitors. It operates with input voltages down to 1.8V. The LDOs offer a maximum dropout voltage of 160mV at rated output current. LDO1 supports a current limit feature. Its output voltage is adjustable using a resistor divider at FB\_LDO1 for TPS65721. The LDO1 voltage is fixed to 1.85V for TPS65720.

## Default Voltage Setting for LDOs and DCDC1

In TPS65721, both DCDC1 and LDO1 are externally adjustable.

For TPS65720, the output voltage of the DCDC1 converter is externally adjustable and for LDO1 it is fixed to 1.85V per default. The I2C registers do allow changing the default voltage for LDO1 in a range of 0.8V to 3.3V. For DCDC1, the register also allows setting any voltage in the range from 0.8V to 3.3V, however for the adjustable version of DCDC1, the change in the I2C register has no effect on the output voltage. The registers will be set to the default value when the voltage at SYS drops below the undervoltage lockout threshold or by a reset event ( $\overline{\text{RESET}}$  output is actively pulled low). See the register description for more details.

## GPIOs, LED Drivers

TPS65720 contains 4 standard input/output pins (GPIOs) named GPIO0 to GPIO3. The output driver/input buffer is available in register GPIO\_SSC while register GPIODIR selects the data direction and additional features. After RESET, GPIO0 and GPIO1 are pre-defined as general purpose inputs while GPIO2 and GPIO3 are configured as LED driver outputs which are high impedance. The LED driver outputs are designed to be constant current sinks to GND, sinking a constant current of 5mA when enabled. The GPIOs do not have internal pull-up resistors. External pull-up resistors might be required if configured as inputs or outputs.

## RESET output

Actively low, open drain reset output. Connect external pull-up resistor. The reset pin will go high impedance 100ms after the reset condition is left. For TPS65720, reset is generated, depending on the power-good signal of LDO1, when the output voltage is below the threshold or LDO1 is disabled. For TPS65721, reset is generated depending on the voltage at pin THRESHOLD.

## THRESHOLD INPUT (TPS65721 only)

This is an input to the comparator driving the  $\overline{\text{Reset}}$  output. If the voltage applied at THRESHOLD is below the threshold,  $\overline{\text{Reset}}$  is pulled actively LOW. If the voltage rises above the threshold + hysteresis, the  $\overline{\text{Reset}}$  output is released after a delay time of 100ms (typically).

## ENABLE for DCDC1 and LDO1

The DCDC1 converter and LDO1 are enabled as soon as  $\overline{\text{PB\_IN}}$  is pulled LOW OR input voltage at pin AC is detected ( $\langle \text{CH\_PGOOD} \rangle = 1$ ).

There is a power-hold pin for DCDC1 (HOLD\_DCDC1) and one for LDO1 (HOLD\_LDO1). When HOLD\_DCDC1 is pulled HIGH, DCDC1 is kept enabled after  $\overline{\text{PB\_IN}}$  was released HIGH. HOLD\_LDO1 serves the same function and keeps LDO1 enabled after  $\overline{\text{PB\_IN}}$  was released HIGH. After first power-up by pulling  $\overline{\text{PB\_IN}} = \text{LOW}$  or applying voltage at AC, the HOLD pins HOLD\_DCDC1 and HOLD\_LDO1 can also be used as enable pins, such that they turn on LDO1 or DCDC1, respectively when they are pulled HIGH. This function is available as long as there is a voltage at the battery. After the battery was removed or was discharged, first power-on needs to be done by pulling  $\overline{\text{PB\_IN}} = \text{LOW}$ .

Disabling the DCDC converter or LDO, forces the device into shutdown, with a shutdown quiescent current as defined in the electrical characteristics. In this mode, the low and high side MOSFETs are turned-off and the entire internal control circuitry is switched-off. For proper operation the  $\overline{\text{PB\_IN}}$ , HOLD\_DCDC1, EN\_DLO1 pins must be terminated and must not be left floating.

### $\overline{\text{PB\_IN}}$ Input

Enables DCDC1 and LDO1 if pulled to GND. Disables DCDC1 and LDO1 if pulled high. There is no internal pull-up resistor, so a resistor is needed externally to SYS. SYS is preferred over BAT because it is powered by either AC or BAT (whichever is higher). If BAT is used, the device may not get a valid HIGH signal if the battery is deeply discharged even when there is voltage at AC.

The input signal is debounced internally by 50ms. When  $\overline{\text{PB\_IN}}$  is pulled low, the DCDC1 converter and LDO1 will power-up simultaneously. When  $\overline{\text{PB\_IN}}$  is de-asserted, both converters are turned off. To leave the converters on, the HOLD\_DCDC1 and HOLD\_LDO1 pin need to be asserted high. The HOLD register Bit <CONTROL1:B5> will keep both, DCDC1 and LDO1 enabled if set to 1. For proper operation the  $\overline{\text{PB\_IN}}$ , HOLD\_DCDC1 and HOLD\_LDO1 pins must be terminated and must not be left floating.

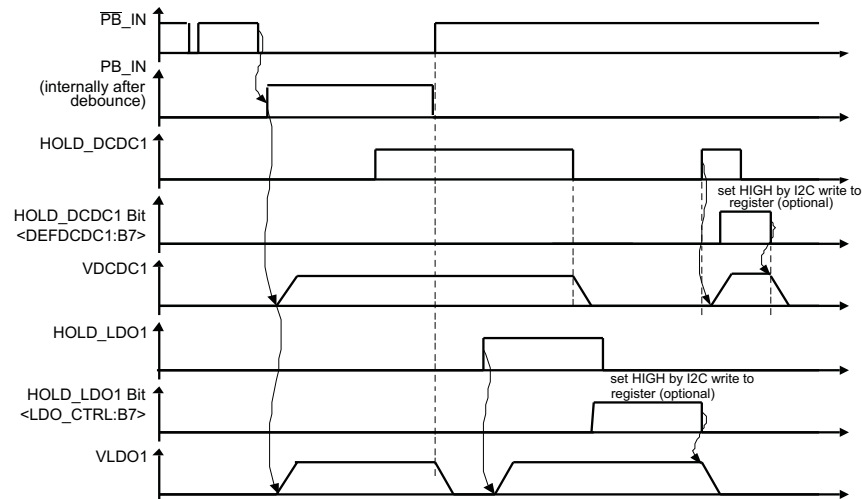

Figure 27.  $\overline{\text{PB\_IN}}$  Timing

### HOLD\_DCDC1 Input

Actively high hold input for DCDC1. Logically OR'ed with the DCDC1 hold Bit <DEFDCDC1:B7>. If the input is driven HIGH after  $\overline{\text{PB\_IN}}$  was pulled LOW, the DCDC1 converter stays on after  $\overline{\text{PB\_IN}}$  was released.

### HOLD\_LDO1 Input

Actively high hold input for LDO1. Logically OR'ed with the LDO1 hold Bit <LDO\_CTRL:B7>. If the input is driven HIGH after  $\overline{\text{PB\_IN}}$  was pulled LOW, LDO1 stays on after  $\overline{\text{PB\_IN}}$  was released.

## INT Output

Actively low, open drain interrupt output. Connect external pull-up resistor. Interrupts are flagged in the registers IR0, IR1 and IR2 if the interrupt is not masked by registers IRMASK0, IRMASK1 and IRMASK2. Per default, all interrupts are masked. Interrupts which are unmasked will set the Bit in either on the rising edge or on both edges. Details can be found in the register description for IR0, IR1 and IR2. Any Bit in IR0, IR1 and IR2, set to "1" will drive the reset pin INT actively LOW.

The reset pin will go high impedance after the Bit, generating the reset is read.

## Serial Interface

The serial interface is compatible with the standard and fast mode I2C specifications, allowing transfers at up to 400kHz. The interface adds flexibility to the power supply solution, enabling most functions to be programmed to new values depending on the instantaneous application requirements and charger status to be monitored. Register contents remain intact as long as VCC remains above the UVLO threshold. The TPS65720 has a 7bit address: '100 1000', other addresses are available upon contact with the factory. Attempting to read data from register addresses not listed in this section will result in 00h being read out.

For normal data transfer, DATA is allowed to change only when CLK is low. Changes when CLK is high are reserved for indicating the start and stop conditions. During data transfer, the data line must remain stable whenever the clock line is high. There is one clock pulse per bit of data. Each data transfer is initiated with a start condition and terminated with a stop condition. When addressed, the TPS65720 device generates an acknowledge bit after the reception of each byte. The master device (microprocessor) must generate an extra clock pulse that is associated with the acknowledge bit. The TPS65720 device must pull down the DATA line during the acknowledge clock pulse so that the DATA line is a stable low during the high period of the acknowledge clock pulse. The DATA line is a stable low during the high period of the acknowledge-related clock pulse. Setup and hold times must be taken into account. During read operations, a master must signal the end of data to the slave by not generating an acknowledge bit on the last byte that was clocked out of the slave. In this case, the slave TPS65720 device must leave the data line high to enable the master to generate the stop condition.

For the QFN version, the voltage the pull-up resistors for the I2C interface at SCLK and SDAT are connected to, should be monitored by the reset circuitry. This is done by connecting THRESHOLD with a voltage divider to the voltage the SDAT and SCLK pins are pulled-up to. This is needed to ensure a falling supply voltage will cause a reset to the I2C interface. Otherwise a START condition may be detected and the first access to the I2C interface may return NO ACK (no acknowledge).

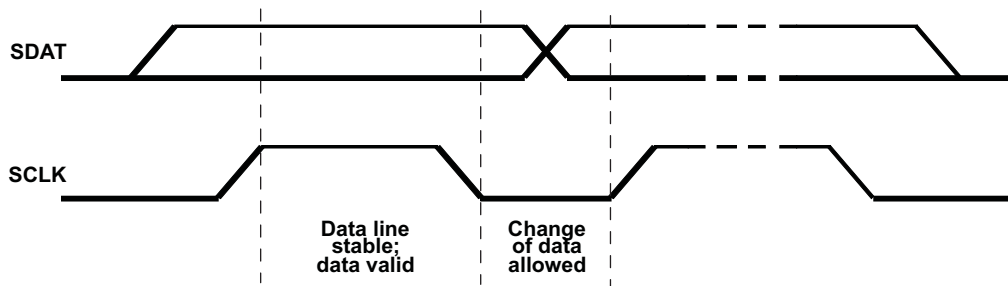

Figure 28. Bit Transfer on the Serial Interface

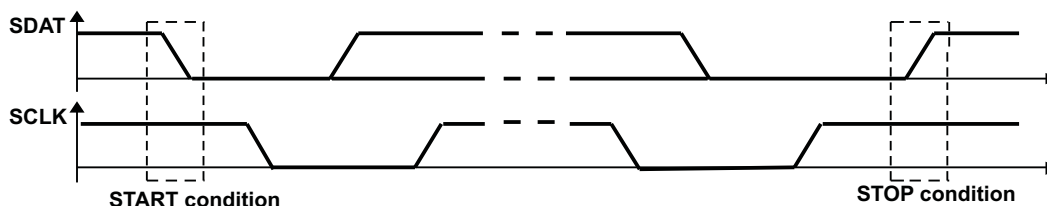
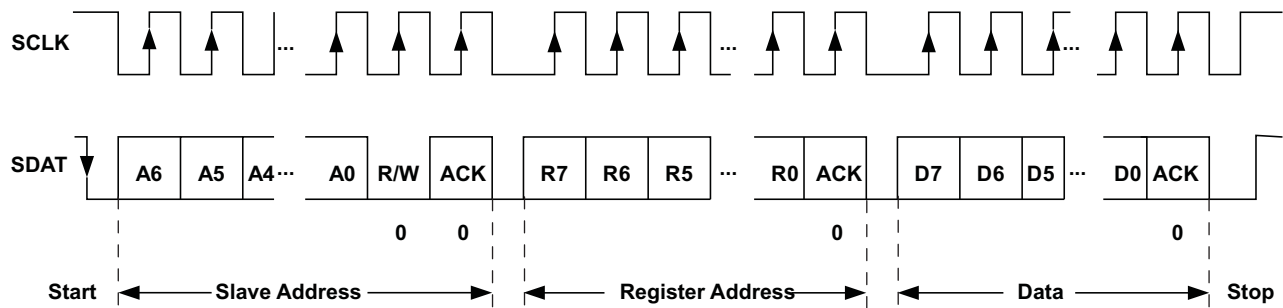
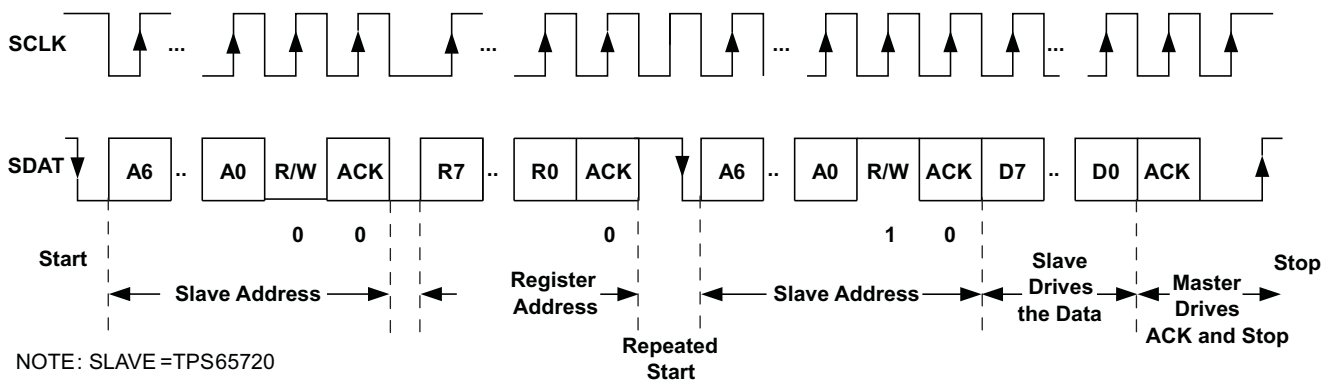

Figure 29. START and STOP Conditions



NOTE: SLAVE =TPS65720

Figure 30. Serial I/f WRITE to TPS65720 Device



NOTE: SLAVE =TPS65720

Figure 31. Serial I/f READ From TPS65720: Protocol A

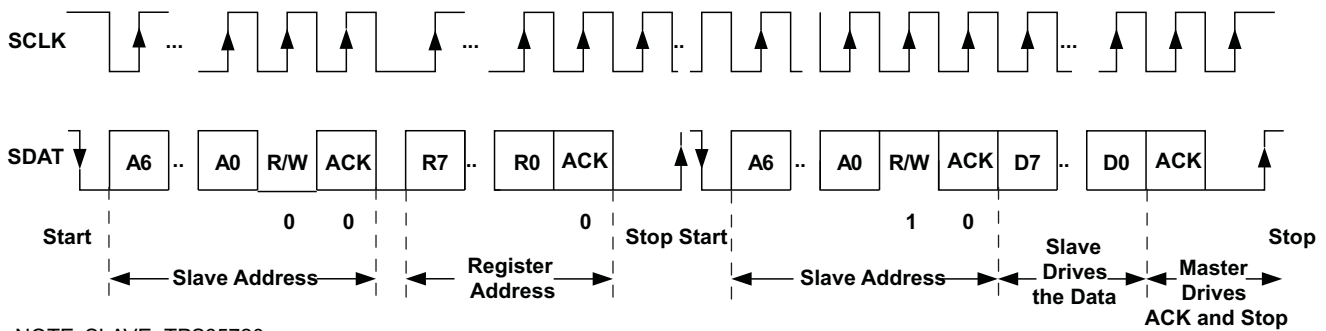

NOTE: SLAVE=TPS65720

Figure 32. Serial I/f READ From TPS65720: Protocol B

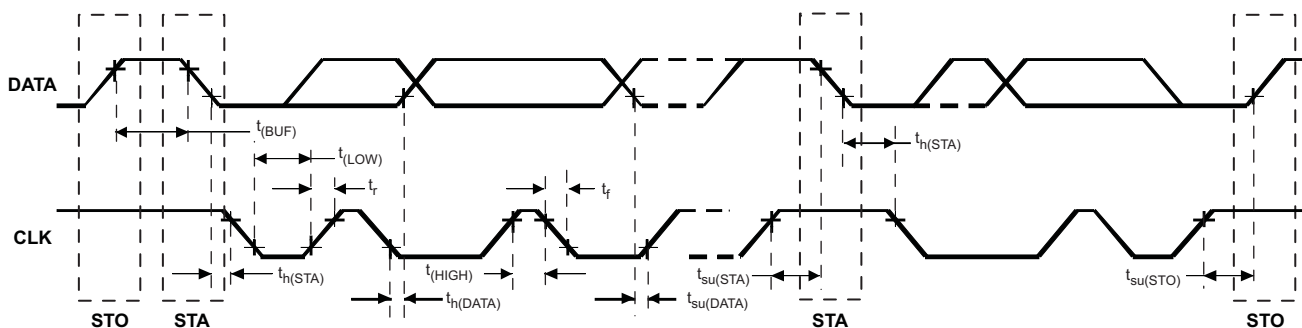

Figure 33. Serial I/f Timing Diagram

		MIN	MAX	UNIT
$f_{MAX}$	Clock frequency		400	kHz
$t_{WH(HIGH)}$	Clock high time	600		ns
$t_{WL(LOW)}$	Clock low time	1300		ns
$t_R$	DATA and CLK rise time		300	ns
$t_F$	DATA and CLK fall time		300	ns
$t_{h(STA)}$	Hold time (repeated) START condition (after this period the first clock pulse is generated)	600		ns
$t_{h(DATA)}$	Setup time for repeated START condition	600		ns
$t_{h(DATA)}$	Data input hold time	0		ns
$t_{su(DATA)}$	Data input setup time	100		ns
$t_{su(STO)}$	STOP condition setup time	600		ns
$t_{(BUF)}$	Bus free time	1300		ns

All registers are set to their default value by one of the following events:

- Voltage at the SYS pin is below the undervoltage lockout voltage (UVLO)
- RESET is active;  $\overline{RESET}$  output is pulled LOW and goes high with a 100ms delay

**CHGSTATUS Register Address: 01h (read only)**

CHGSTATUS	B7	B6	B5	B4	B3	B2	B1	BO
Bit name and function	TS_HOT	TS_COLD	OVP		CH_ACTIVE	CH_PGOOD	CH_THLOOP	
Default	x	x	x	0	x	x	x	0
Default value loaded by:								
Read/write	R	R	R	R	R	R	R	R

- Bit 7 TS\_HOT:  
0 = battery temperature is below high temperature threshold (45°C/50°C/55°C/60°C).  
1 = battery temperature is above high temperature threshold (45°C/50°C/55°C/60°C).
- Bit 6 TS\_COLD:  
0 = battery temperature is above low temperature threshold (0°C/5°C/10°C/15°C)  
1 = battery temperature is below low temperature threshold (0°C/5°C/10°C/15°C)
- Bit 5 OVP:  
0 = Input overvoltage protection is not active (VAC<6.6V)  
1 = Input overvoltage protection is active (VAC>6.6V)
- Bit 3 CH\_ACTIVE:  
0 = charger is not active  
1 = charger is charging the battery
- Bit 2 CH\_PGOOD:  
0 = no input voltage at pin AC or voltage not inside the voltage range for charging  
1 = power source is present and in the range valid for charging
- Bit 1 CH\_THLOOP:  
0 = thermal loop not active  
1 = thermal loop active

**CHGCONFIG0 Register Address: 02h (read/write)**

CHGCONFIG0	B7	B6	B5	B4	B3	B2	B1	B0
Bit name and function	VSYS1	VSYS0	AC input current1	AC input current0	TH_LOOP	DYN_TMR	TERM_EN	CH_EN
Default For TPS65720 For TPS65721	0 1	1 0	1 1	0 0	1 1	1 1	1 1	1 1
Default value loaded by:	UVLO/R	UVLO/R	UVLO/R	UVLO/R	UVLO/R	UVLO/R	UVLO/R	UVLO/R
Read/write	R/W	R/W	R/W	R/W	R/W	R/W	R/W	R/W

**Bit 7..6 VSYS1..VSYS0:**

00 = the output voltage of the power path at pin SYS tracks the battery voltage;  
 VSYS=VBAT+200mV (Vbat>3.3V); VSYS=3.4V (VBAT</=3.3V); V\_DPPM=1 is forced in this case  
 01 = the output voltage of the power path at pin SYS is regulated to 4.4V  
 10 = the output voltage of the power path at pin SYS is regulated to 5.0V  
 11 = the output voltage of the power path at pin SYS is regulated to 5.5V

**Bit 5..4 AC input current1.. AC input current0:**

00 = 100mA, input voltage DPPM enabled  
 01 = 500mA, input voltage DPPM enabled  
 10 = 500mA, input voltage DPPM disabled  
 11 = USB suspend mode; standby

**Bit 3 TH\_LOOP:**

0 = the thermal loop is disabled  
 1 = the thermal loop is enabled and the charge current is reduced if the temperature exceeds 125°C

**Bit 2 DYN\_TMR (dynamic timer function):**

0 = safety timers run with their normal clock speed  
 1 = clock speed for the safety timers is reduced based on the actual charge current if DPPM or thermal loop is active

**Bit 1 TERM\_EN (charge termination enable):**

0 = charge termination will not occur and the charger will always be on  
 1 = charge termination enabled based on timers and termination current

**Bit 0 CH\_EN:**

0 = the charger is disabled  
 1 = the charger is enabled

**CHGCONFIG1 Register Address: 03h (read/write)**

CHGCONFIG1	B7	B6	B5	B4	B3	B2	B1	BO
Bit name and function	I_PRE1	I_PRE0	ICH_SCL1	ICH_SCL0	I_TERM1	I_TERM0		
Default For TPS65720 For TPS65721	0 0	1 1	0 1	1 1	0 0	1 1	0	0
Default value loaded by:	UVLO/R	UVLO/R	UVLO/R	UVLO/R	UVLO/R	UVLO/R		
Read/write	R/W	R/W	R/W	R/W	R/W	R/W	R	R

Bit 7..6 I\_PRE1..I\_PRE0 (Pre-charge current factor):

- 00 = 5% of value defined with ICH\_SCL1, ICH\_SCL0
- 01 = 10% of value defined with ICH\_SCL1, ICH\_SCL0
- 10 = 15% of value defined with ICH\_SCL1, ICH\_SCL0
- 11 = 20% of value defined with ICH\_SCL1, ICH\_SCL0

Bit 5..4 ICH\_SCL1..ICH\_SCL0 (charge current scaling factor):

- 00 = 25% of value defined with ISET resistor; safety timer will time out at 2x SFTY\_TMR[0,1]
- 01 = 50% of value defined with ISET resistor; safety timer runs at its nominal time defined in SFTY\_TMR[0,1]
- 10 = 75% of value defined with ISET resistor; safety timer will time out at 0.66x SFTY\_TMR[0,1]
- 11 = 100% of value defined with ISET resistor; safety timer will time out at 0.5x SFTY\_TMR[0,1]

Bit 3..2 I\_TERM1..I\_TERM0 (termination current scaling factor):

- 00 = 5% of value defined with ICH\_SCL1, ICH\_SCL0
- 01 = 10% of value defined with ICH\_SCL1, ICH\_SCL0
- 10 = 15% of value defined with ICH\_SCL1, ICH\_SCL0
- 11 = 20% of value defined with ICH\_SCL1, ICH\_SCL0



**CHGCONFIG2 Register Address: 04h (read/write)**

CHGCONFIG2	B7	B6	B5	B4	B3	B2	B1	BO
Bit name and function	SFTY_TMR1 0	SFTY_TMR	PRE_TMR		NTC	V_DPPM	VBAT_COMP_EN	
Default	0	1	0	0	1	1	0	0
Default value loaded by:	UVLO/R	UVLO/R	UVLO/R		UVLO/R	UVLO/R	UVLO/R	
Read/write	R/W	R/W	R/W	R	R/W	R/W	R/W	R

Bit 7..6 SFTY\_TMR1..SFTY\_TMR0 (charge safety timer value):

- 00 = 4h
- 01 = 5h
- 10 = 6h
- 11 = 8h

Bit 5 PRE\_TMR (pre-charge timer value):

- 0 = 30min
- 1 = 60min

Bit 3 NTC (sensor resistance):

- 0 = 100k NTC (I=7.5uA)
- 1 = 10k NTC (I=75uA)

Bit 2 V\_DPPM (dynamic power path threshold):

- 0 = VBAT+100mV
- 1 = 4.3V

Bit 1 VBAT\_COMP\_EN (battery voltage comparator enable):

- 0 = battery voltage comparator for Li-primary cells disabled; VBAT\_COMP interrupt disabled
- 1 = battery voltage comparator for Li-primary cells enabled

**CHGCONFIG3 Register Address: 05h (read/write)**

CHGCONFIG3	B7	B6	B5	B4	B3	B2	B1	B0
Bit name and function	CH_VLTG2	CH_VLTG1	CH_VLTG0	TMP_SHIFT1	TMP_SHIFT0	VBAT1	VBAT0	VBAT_COMP
Default	0	1	0	0	0	0	0	1
Default value loaded by:	UVLO/R	UVLO/R	UVLO/R	UVLO/R	UVLO/R	UVLO/R	UVLO/R	UVLO/R
Read/write	R/W	R/W	R/W	R/W	R/W	R/W	R/W	R

Bit 7..5 CH\_VLTG2..CH\_VLTG0 (charge voltage selection):

- 000 = 4.15V
- 001 = 4.175V
- 010 = 4.20V
- 011 = 4.225V
- 100 = 4.25V
- 101 = 4.275V
- 110 = 4.30V
- 111 = 4.325V

Bit 4..3 TMP\_SHIFT1..TMP\_SHIFT0 (battery temperature shift):

- 00 = the temperature for TS\_COLD and TS\_HOT is at 0°C/45°C
- 01 = the temperature window is shifted by 5°C to TS\_COLD/TS\_HOT = 5°C/50°C
- 10 = the temperature window is shifted by 10°C to TS\_COLD/TS\_HOT = 10°C/55°C
- 11 = the temperature window is shifted by 15°C to TS\_COLD/TS\_HOT = 15°C/60°C

Bit 2..1 VBAT1..VBAT0 (battery voltage comparator threshold; for Li primary cells):

- 00 = 2.2V
- 01 = 2.3V
- 10 = 2.4V
- 11 = 2.5V

Bit 0 VBAT\_COMP (battery voltage comparator output):

- 0 = voltage above the threshold
- 1 = voltage below the threshold or comparator disabled

**CHGSTATE Register Address: 06h (read only)**

CHGSTATE	B7	B6	B5	B4	B3	B2	B1	B0
Bit name and function	CH_SLEEP	CH_RESET	CH_IDLE	CH_PRECH	CH_CC	CH_LDO	CH_FAULT	CH_SUSP
Default	X	X	X	X	X	X	X	X
Read/write	R	R	R	R	R	R	R	R

- Bit 7      **CH\_SLEEP:**  
 0 = charger is not in sleep state  
 1 = charger is in sleep state
- Bit 6      **CH\_RESET:**  
 0 = charger is not in reset state  
 1 = charger is in reset state
- Bit 5      **CH\_IDLE:**  
 0 = charger is not in idle state  
 1 = charger is in idle state
- Bit 4      **CH\_PRECH:**  
 0 = charger is not in pre-charge state  
 1 = charger is in pre-charge state
- Bit 3      **CH\_CC:**  
 0 = charger is not in constant current mode  
 1 = charger is in constant current mode
- Bit 2      **CH\_LDO:**  
 0 = charger is not in LDO mode  
 1 = charger is in LDO mode
- Bit 1      **CH\_FAULT:**  
 0 = charger is not in fault state  
 1 = charger is in fault state
- Bit 0      **CH\_SUSP:**  
 0 = charger is not in suspend state  
 1 = charger is in suspend state

**DEFDCDC1 Register Address: 07h (read/write)**

DEFDCDC1	B7	B6	B5	B4	B3	B2	B1	B0
Bit name and function	HOLD_DCDC1	DCDC_DISCH	DCDC1[5]	DCDC1[4]	DCDC1[3]	DCDC1[2]	DCDC1[1]	DCDC1[0]
Default	0	0	1	0	1	0	0	1
Default value loaded by:	UVLO/R	UVLO/R	UVLO/R	UVLO/R	UVLO/R	UVLO/R	UVLO/R	UVLO/R
Read/write	R/W	R/W	R/W	R/W	R/W	R/W	R/W	R/W

Bit 7      **HOLD\_DCDC1:**  
 0 = DCDC1 is disabled when HOLD\_DCDC1 pin is pulled LOW and  $\overline{\text{PB\_IN}}$  is released HIGH  
 1 = DCDC1 stays enabled when HOLD\_DCDC1 pin is pulled LOW and  $\overline{\text{PB\_IN}}$  is released HIGH

Bit 6      **DCDC\_DISCH:**  
 0 = DCDC1 output is not discharged when DCDC1 is disabled  
 1 = DCDC1 output is discharged when DCDC1 is disabled

Bit 5..0    **Output voltage setting for DCDC1:**  
 For reference only: A voltage change in the register will not have an effect on the output voltage for TPS65720 and TPS65721 as the voltage is set by an external resistor divider. Contact TI in case a fixed voltage version is needed.

A Voltage change during operation must not exceed 8% of the value set in the register for each I2C write access as this may trigger the internal power good comparator and will trigger the Reset of the device. This limitation is only for a voltage step to higher voltages. There is no limitation for programming lower voltages by I2C.

	OUTPUT VOLTAGE [V]	B5	B4	B3	B2	B1	B0
0	0.800	0	0	0	0	0	0
1	0.825	0	0	0	0	0	1
2	0.850	0	0	0	0	1	0
3	0.875	0	0	0	0	1	1
4	0.900	0	0	0	1	0	0
5	0.925	0	0	0	1	0	1
6	0.950	0	0	0	1	1	0
7	0.975	0	0	0	1	1	1
8	1.000	0	0	1	0	0	0
9	1.025	0	0	1	0	0	1
10	1.050	0	0	1	0	1	0
11	1.075	0	0	1	0	1	1
12	1.100	0	0	1	1	0	0
13	1.125	0	0	1	1	0	1
14	1.150	0	0	1	1	1	0
15	1.175	0	0	1	1	1	1
16	1.200	0	1	0	0	0	0
17	1.225	0	1	0	0	0	1
18	1.250	0	1	0	0	1	0
19	1.275	0	1	0	0	1	1
20	1.300	0	1	0	1	0	0
21	1.325	0	1	0	1	0	1
22	1.350	0	1	0	1	1	0
23	1.375	0	1	0	1	1	1
24	1.400	0	1	1	0	0	0

	OUTPUT VOLTAGE [V]	B5	B4	B3	B2	B1	B0
25	1.425	0	1	1	0	0	1
26	1.450	0	1	1	0	1	0
27	1.475	0	1	1	0	1	1
28	1.500	0	1	1	1	0	0
29	1.525	0	1	1	1	0	1
30	1.550	0	1	1	1	1	0
31	1.575	0	1	1	1	1	1
32	1.600	1	0	0	0	0	0
33	1.650	1	0	0	0	0	1
34	1.700	1	0	0	0	1	0
35	1.750	1	0	0	0	1	1
36	1.800	1	0	0	1	0	0
37	1.850	1	0	0	1	0	1
38	1.900	1	0	0	1	1	0
39	1.950	1	0	0	1	1	1
40	2.000	1	0	1	0	0	0
41	2.050	1	0	1	0	0	1
42	2.100	1	0	1	0	1	0
43	2.150	1	0	1	0	1	1
44	2.200	1	0	1	1	0	0
45	2.250	1	0	1	1	0	1
46	2.300	1	0	1	1	1	0
47	2.350	1	0	1	1	1	1
48	2.400	1	1	0	0	0	0
49	2.450	1	1	0	0	0	1
50	2.500	1	1	0	0	1	0
51	2.550	1	1	0	0	1	1
52	2.600	1	1	0	1	0	0
53	2.650	1	1	0	1	0	1
54	2.700	1	1	0	1	1	0
55	2.750	1	1	0	1	1	1
56	2.800	1	1	1	0	0	0
57	2.850	1	1	1	0	0	1
58	2.900	1	1	1	0	1	0
59	2.950	1	1	1	0	1	1
60	3.000	1	1	1	1	0	0
61	3.100	1	1	1	1	0	1
62	3.200	1	1	1	1	1	0
63	3.300	1	1	1	1	1	1

**LDO\_CTRL Register Address: 08h (read/write)**

LDO_CTRL	B7	B6	B5	B4	B3	B2	B1	B0
Bit name and function	HOLD_LDO1	LDO1_DISCH	LDO1[5]	LDO1[4]	LDO1[3]	LDO1[2]	LDO1[1]	LDO1[0]
Default	0	1	1	0	0	1	0	1
Default value loaded by:	UVLO/R	UVLO/R	UVLO/R	UVLO/R	UVLO/R	UVLO/R	UVLO/R	UVLO/R
Read/write	R/W	R/W	R/W	R/W	R/W	R/W	R/W	R/W

- Bit 7     **HOLD\_LDO1:**  
0 = LDO1 is disabled when HOLD\_LDO1 pin is pulled LOW and  $\overline{\text{PB\_IN}}$  is released HIGH  
1 = LDO1 stays enabled when HOLD\_LDO1 pin is pulled LOW and  $\overline{\text{PB\_IN}}$  is released HIGH
- Bit 6     **LDO1\_DISCH:**  
0 = LDO1 output is not discharged when LDO1 is disabled  
1 = LDO1 output is discharged when LDO1 is disabled
- Bit 5..0     **LDO1 output voltage setting according to the table listed for DCDC1:**  
The voltage setting is only valid for TPS65720. For TPS65721, the LDO1 voltage is set by an external resistor divider. The voltage setting is according to the same table given for DEFDCDC1.

**CONTROL0 Register Address: 09h (read/write)**

CONTROL0	B7	B6	B5	B4	B3	B2	B1	B0
Bit name and function	F_PWM	PGOODZ_DCDC1	PGOODZ_LDO1					
Default	0	PGOODDCDC1	PGOODLDO1	0	0	0	0	0
Default value loaded by:	UVLO/R							
Read/write	R/W	R	R	R	R	R	R	R

- Bit 7     **F\_PWM:**  
0 = DCDC converter is in PWM/PFM mode  
1 = DCDC converter is in forced PWM mode
- Bit 6     **PGOODZ\_DCDC1:**  
0 = indicates that the DCDC converters output voltage is within its nominal range  
1 = range indicates that the DCDC converters output voltage is below the target regulation voltage or disabled
- Bit 5     **PGOODZ\_LDO1:**  
0 = indicates that the LDO1 output voltage is within its nominal range  
1 = indicates that the LDO1 output voltage is below the target regulation voltage or disabled

**CONTROL1 Register Address: 0Ah (read/write)**

CONTROL1	B7	B6	B5	B4	B3	B2	B1	B0
Bit name and function			HOLD	PB_STAT				RESET_DELAY
Default	0	0	0		0	1	0	1
Default value loaded by:			UVLO/R	UVLO/R				UVLO/R
Read/write	R	R	R	R/W	R	R	R	R/W

- Bit 5 HOLD (ORed with  $\overline{\text{PB\_IN}}$ ):  
 0 = DCDC1 and LDO1 switched off  
 1 = DCDC1 and LDO1 enabled
- Bit 4 PB\_STAT (push-button status, after debounce):  
 0 = push-button not pressed  
 1 = push-button pressed
- Bit 0 RESET\_DELAY:  
 0 = 11ms  
 1 = 90ms

**GPIO\_SSC Register Address: 0Bh (read/write)**

GPIO_SSC	B7	B6	B5	B4	B3	B2	B1	B0
Bit name and function					GPIO3	GPIO2	GPIO1	GPIO0
Default	0	0	0	0	1	1	1	1
Default value loaded by:					UVLO/R	UVLO/R	UVLO/R	UVLO/R
Read/write	R	R	R	R/W	R	R	R	R/W

- Bit 3 GPIO3:  
 0 = data in input buffer / actively pulled low when configured as an output or LED driver enabled  
 1 = data in input buffer / high impedance when configured as an output or LED driver
- Bit 2 GPIO2:  
 0 = data in input buffer / actively pulled low when configured as an output or LED driver enabled  
 1 = data in input buffer / high impedance when configured as an output or LED driver
- Bit 1 GPIO1:  
 0 = data in input buffer / actively pulled low when configured as an output  
 1 = data in input buffer / high impedance when configured as an output
- Bit 0 GPIO0:  
 0 = data in input buffer / actively pulled low when configured as an output  
 1 = data in input buffer / high impedance when configured as an output

**GPIODIR Register Address: 0Ch (read/write)**

GPIODIR	B7	B6	B5	B4	B3	B2	B1	B0
Bit name and function	GPIO3_LED	GPIO2_LED			GPIO3_DIR	GPIO2_DIR	GPIO1_DIR	GPIO0_DIR
Default	1	1	1	1	0	0	1	1
Default value loaded by:	UVLO/R	UVLO/R			UVLO/R	UVLO/R	UVLO/R	UVLO/R
Read/write	R/W	R/W	R	R	R/W	R/W	R/W	R/W

- Bit 7 GPIO3\_LED:  
0 = GPIO3 is configured as a standard GPIO  
1 = GPIO3 is configured as 5mA LED driver
- Bit 6 GPIO2\_LED:  
0 = GPIO2 is configured as a standard GPIO  
1 = GPIO2 is configured as 5mA LED driver
- Bit 3 GPIO3\_DIR:  
0 = GPIO3 is configured as an output / LED driver  
1 = GPIO3 is configured as an input
- Bit 2 GPIO2\_DIR:  
0 = GPIO2 is configured as an output / LED driver  
1 = GPIO2 is configured as an input
- Bit 1 GPIO1\_DIR:  
0 = GPIO1 is configured as an output  
1 = GPIO1 is configured as an input
- Bit 0 GPIO0\_DIR:  
0 = GPIO0 is configured as an output  
1 = GPIO0 is configured as an input

**IRMASK0 Register Address: 0Dh (read/write)**

IRMASK0	B7	B6	B5	B4	B3	B2	B1	B0
Bit name and function	M_TS_HOT	M_TS_COLD	M_OVP	M_TIMER_FAULT	M_CH_ACTIVE	M_CH_PGOOD	M_VBAT_COMP	M_THLOOP
Default	1	1	1	1	1	1	1	1
Default value loaded by:	UVLO/R	UVLO/R	UVLO/R	UVLO/R	UVLO/R	UVLO/R	UVLO/R	UVLO/R
Read/write	R/W	R/W	R/W	R/W	R/W	R/W	R/W	R/W

- Bit 7..0 charger interrupt mask register:  
0 = Interrupt not masked  
1 = Interrupt masked (no interrupt based on the event)



**IRMASK1 Register Address: 0Eh (read/write)**

IRMASK1	B7	B6	B5	B4	B3	B2	B1	B0
Bit name and function	M_CH_SLEEP	M_CH_RESET	M_CH_IDLE	M_CH_PRECH	M_CH_CC	M_CH_LDO	M_CH_FAULT	M_CH_SUSP
Default	1	1	1	1	1	1	1	1
Default value loaded by:	UVLO/R	UVLO/R	UVLO/R	UVLO/R	UVLO/R	UVLO/R	UVLO/R	UVLO/R
Read/write	R/W	R/W	R/W	R/W	R/W	R/W	R/W	R/W

Bit 7..0 charger state interrupt mask register:  
 0 = Interrupt not masked  
 1 = Interrupt masked (no interrupt based on the event)

**IRMASK2 Register Address: 0Fh (read/write)**

IRMASK2	B7	B6	B5	B4	B3	B2	B1	B0
Bit name and function	M_GPIO3	M_GPIO2	M_GPIO1	M_GPIO0	M_PGOODZ_DCDC1	M_PGOODZ_LDO1	M_PB_STAT	
Default	1	1	1	1	1	1	1	1
Default value loaded by:	UVLO/R	UVLO/R	UVLO/R	UVLO/R	UVLO/R	UVLO/R	UVLO/R	
Read/write	R/W	R/W	R/W	R/W	R/W	R/W	R/W	R

Bit 7..0 charger state interrupt mask register:  
 0 = Interrupt not masked  
 1 = Interrupt masked (no interrupt based on the event)

**IR0 Register Address: 10h (read only)**

IR0	B7	B6	B5	B4	B3	B2	B1	B0
Bit name and function	TS_HOT	TS_COLD	OVP	TIMER_FAULT	CH_ACTIVE	CH_PGOOD	VBAT_COMP	TH_LOOP
Default	0	0	0	0	0	0	0	0
Default value loaded by:	UVLO/R	UVLO/R	UVLO/R	UVLO/R	UVLO/R	UVLO/R	UVLO/R	UVLO/R
Set by:	Rising edge of TS_HOT	Rising edge of TS_COLD	Rising edge of OVP	Rising edge of TIMER_FAULT	Rising edge and falling edge of CH_ACTIVE	Rising edge and falling edge of CH_PGOOD	Rising edge of VBAT_COMP*	Rising edge of TH_LOOP
Read/write	R	R	R	R	R	R	R	R

Bit 7..2 interrupt register:  
 0 = no interrupt  
 1 = Interrupt occurred (cleared when read); interrupt not masked in register IRMASK0

The VBAT\_COMP interrupt is automatically disabled when the battery voltage comparator is disabled by clearing Bit 1 in register 04h (VBAT\_COMP\_EN)

**IR1 Register Address: 11h (read)**

IR1	B7	B6	B5	B4	B3	B2	B1	B0
Bit name and function	CH_SLEEP	CH_RESET	CH_IDLE	CH_PRECH	CH_CC	CH_LDO	CH_FAULT	CH_SUSP
Default	0	0	0	0	0	0	0	0
Default value loaded by:	UVLO/R	UVLO/R	UVLO/R	UVLO/R	UVLO/R	UVLO/R	UVLO/R	UVLO/R
Set by:	Rising edge of CH_SLEEP	Rising edge of CH_RESET	Rising edge of CH_IDLE	Rising edge of CH_PRECH	Rising edge of CH_CC	Rising edge of CH_LDO	Rising edge of VBAT_FAULT*	Rising edge of TH_SUSP
Read/write	R	R	R	R	R	R	R	R

Bit 7..0 interrupt register:  
 0 = no interrupt  
 1 = Interrupt occurred (cleared when read); interrupt not masked in register IRMASK1

**IR2 Register Address: 12h (read)**

IR2	B7	B6	B5	B4	B3	B2	B1	B0
Bit name and function	GPIO3	GPIO2	GPIO1	GPIO0	PGOODZ_DCDC1	PGOODZ_LDO1	PB_STAT	
Default	0	0	0	0	0	0	0	0
Default value loaded by:	UVLO/R	UVLO/R	UVLO/R	UVLO/R	UVLO/R	UVLO/R	UVLO/R	
Set by:	Rising and falling edge of GPIO3	Rising and falling edge of GPIO2	Rising and falling edge of GPIO1	Rising and falling edge of GPIO0	Rising edge of PGOODZ_DCDC1	Rising edge of PGOODZ_LDO1	Rising and falling edge of PB_STAT	
Read/write	R	R	R	R	R	R	R	R

Bit 7..4 GPIO interrupt register:  
 0 = GPIO status did not change  
 1 = GPIO status changed; cleared when read; interrupt not masked in register IRMASK2

Bit 3..2 power good interrupt register:  
 0 = no interrupt (power good)  
 1 = interrupt occurred (output voltage of DCDC converter or LDO too low); cleared when read

Bit 1 PB\_STAT interrupt register:  
 0 = no interrupt  
 1 = interrupt occurred; cleared when read; interrupt not masked in register IRMASK2

## APPLICATION INFORMATION

### OUTPUT VOLTAGE SETTING

#### DCDC1

The output voltage of the DCDC converter can be set with external resistor network on Pin FB\_DCDC1. The feedback voltage is 0.6V.

It is recommended to set the total resistance of R1 + R2 to less than 1MΩ. Route the FB\_DCDC1 trace separate from noise sources, such as the inductor trace (L1).

$$V_{FB\_DCDC1} = 0.6V$$

$$V_{OUT} = V_{FB\_DCDC1} \times \frac{R1 + R2}{R2} \quad R1 = R2 \times \left( \frac{V_{OUT}}{V_{FB\_DCDC1}} \right) - R2 \quad (1)$$

Typical resistor values:

OUTPUT VOLTAGE	R1	R2	NOMINAL VOLTAGE
3.3V	680k	150k	3.32V
3.0V	510k	130k	2.95V
2.85V	560k	150k	2.84V
2.5V	510k	160k	2.51V
2.05V	360k	150k	2.04V
2.0V	470k	200k	2.01V
1.8V	300k	150k	1.80V
1.6V	200k	120K	1.60V
1.5V	300k	200k	1.50V
1.2V	330k	330k	1.20V

A feed-forward capacitor in parallel to the resistor from Vout to FB\_DCDC1 is required. It's value should be based on transient performance and will be in the range from 4.7pF to 22pF.

#### LDO1

For TPS65720, the output voltage of LDO1 is set by register LDO\_CTRL with the I2C compatible interface. The default output voltage is programmed to 1.85V. The programmable voltage range is 0.8V to 3.3V.

For the TPS65721, the output voltage for LDO1 is externally adjustable using a resistor divider at pin FB\_LDO1. The feedback voltage is 0.8V and the total resistance of the voltage divider should be kept in the 100kΩ to 1MΩ range. A feed-forward capacitor in parallel to the resistor from Vout to FB\_LDO1 is required. It's value should be based on transient performance and will be in the range from 4.7pF to 22pF.

The output voltage with an internal reference voltage  $V_{FB\_LDO1} = 0.8V$  is:

$$V_{OUT} = V_{FB\_LDO1} \times \frac{R3 + R4}{R4} \quad R3 = R4 \times \left( \frac{V_{OUT}}{V_{FB\_LDO1}} \right) - R4 \quad (2)$$

Typical resistor values:

OUTPUT VOLTAGE	R3	R4	NOMINAL VOLTAGE
3.3V	470k	150k	3.31V
1.85V	200k	150k	1.86V
1.8V	300k	240k	1.80V

## OUTPUT FILTER DESIGN (INDUCTOR AND OUTPUT CAPACITOR)

### Inductor Selection

The converter operates typically with 3.3µH output inductor. Larger or smaller inductor values can be used to optimize the performance of the device for specific operation conditions. The selected inductor has to be rated for its DC resistance and saturation current. The DC resistance of the inductance will influence directly the efficiency of the converter. Therefore an inductor with lowest DC resistance should be selected for highest efficiency.

[Equation 3](#) calculates the maximum inductor current under static load conditions. The saturation current of the inductor should be rated higher than the maximum inductor current as calculated with [Equation 3](#). This is recommended because during heavy load transient the inductor current will rise above the calculated value

$$\Delta I_L = V_{out} \times \frac{1 - \frac{V_{out}}{V_{in}}}{L \times f} \quad I_{Lmax} = I_{outmax} + \frac{\Delta I_L}{2} \quad (3)$$

With:

f = Switching Frequency (2.25MHz typical)

L = Inductor Value

ΔI<sub>L</sub> = Peak to Peak inductor ripple current

I<sub>Lmax</sub> = Maximum Inductor current

The highest inductor current will occur at maximum V<sub>in</sub>.

Open core inductors have a soft saturation characteristic and they can usually handle higher inductor currents versus a comparable shielded inductor.

A more conservative approach is to select the inductor current rating just for the maximum switch current of the corresponding converter. It must be considered, that the core material from inductor to inductor differs and will have an impact on the efficiency especially at high switching frequencies.

Refer to [Table 1](#) and the typical applications for possible inductors.

**Table 1. Tested Inductors**

INDUCTOR TYPE	INDUCTOR VALUE	SUPPLIER	Comments
LQM21P	3.3uH	Murata	For TPS65720
BRC1608T2R2M	2.2uH	Taiyo Yuden	For TPS65720; Smallest solution size; up to 150 mA of output current
VLS201610ET-2R2M	2.2uH	TDK	For TPS65720, TPS65721
GLFR1608T2R2M-LR	2.2uH	TDK	For TPS65720; Smallest solution size; up to 150 mA of output current
MIPSA2520	2.2uH	FDK	For TPS65721; highest efficiency

### Output Capacitor Selection

The advanced Fast Response voltage mode control scheme of the step-down converter allows the use of small ceramic capacitors with a typical value of 10µF, without having large output voltage under and overshoots during heavy load transients. Ceramic capacitors having low ESR values result in lowest output voltage ripple and are therefore recommended. For an inductor value of 3.3µH, an output capacitor with 4.7µF can be used. Refer to recommended components.

If ceramic output capacitors are used, the capacitor RMS ripple current rating will always meet the application requirements. Just for completeness the RMS ripple current is calculated as:

$$I_{RMSout} = V_{out} \times \frac{1 - \frac{V_{out}}{V_{in}}}{L \times f} \times \frac{1}{2 \times \sqrt{3}} \quad (4)$$

At nominal load current the inductive converters operate in PWM mode and the overall output voltage ripple is the sum of the voltage spike caused by the output capacitor ESR plus the voltage ripple caused by charging and discharging the output capacitor:

$$\Delta V_{out} = V_{out} \times \frac{1 - \frac{V_{out}}{V_{in}}}{L \times f} \times \left( \frac{1}{8 \times C_{out} \times f} + ESR \right) \quad (5)$$

Where the highest output voltage ripple occurs at the highest input voltage  $V_{in}$ .

At light load currents the converter operates in Power Save Mode and the output voltage ripple is dependent on the output capacitor value. The output voltage ripple is set by the internal comparator delay and the external capacitor. The typical output voltage ripple is less than 1% of the nominal output voltage.

### Input Capacitor Selection

Because of the nature of the buck converter having a pulsating input current, a low ESR input capacitor is required for best input voltage filtering and minimizing the interference with other circuits caused by high input voltage spikes. The converters need a ceramic input capacitor of 4.7 $\mu$ F. The input capacitor can be increased without any limit for better input voltage filtering.

**Table 2. Tested Capacitors**

TYPE	VALUE	VOLTAGE RATING	SIZE	SUPPLIER	MATERIAL
GRM155R60G475ME47D	4.7 $\mu$ F	4 V	0402	Murata	Ceramic X5R
GRM155R60J225ME15D	2.2 $\mu$ F	6.3 V	0402	Murata	Ceramic X5R
GRM188R60J475K	4.7 $\mu$ F	6.3 V	0603	Murata	Ceramic X5R
GMK107BJ105K	1 $\mu$ F	35 V	0603	Taiyo Yuden	Ceramic X5R

## CHARGER/POWER PATH

### Charger Stability

In order to ensure stable operation of the charger including the power path, a list of components and their recommended value is given below. Note that these values represent the capacitance or inductance value in the application under the given operating conditions. For example, ceramic capacitors will typically show a drop in capacitance when a dc voltage is applied. Due to this dc bias effect, the capacitance in the applications when voltage is applied is much less than the nominal capacitor value. See the manufacturers data sheet on this.

At pin AC, a series inductance of may be used with a values as stated below.

Pins AC, SYS and BAT have been tested to be stable with the values given in the table:

PIN NAME	Cmin ( $\mu$ F)	Cmax ( $\mu$ F)	Lmin ( $\mu$ H)	lmax ( $\mu$ H)
AC	0.1	1	0	2
SYS	1	10	–	–
BAT	0.1	4.7	–	–

### Setting the Charge Current

The charge current is set with an external resistor connected form ISET to GND.

The resulting charge current is:

$$I_{CHARGE} = \frac{K_{SET}}{R_{SET}} \quad R_{SET} = \frac{K_{SET}}{I_{SET}} \quad (6)$$

Additionally, the charge current can be scaled to 100%, 75%, 50% or 25% of the value set by Rset by software in register CHCONFIG1 using Bits ICH\_SCL[1,0]. Pre-charge current and termination current is scaled accordingly.

### Dynamic Power Path Management (DPPM)

The charger/power path in TPS6572x contains two different features to ensure there is sufficient power at the load and the input voltage supplying the charger/power path does not collapse.

First there is output voltage DPPM, which is a control loop to keep the voltage at the output of the power path

above a certain limit. In TPS6572x, the voltage at the output of the power path (SYS) is regulated to what is defined with VSYS[1,0] in register CHCONFIG0. When the current needed for the load and for charging the battery exceeds the input current limit, the voltage at SYS will collapse. The DPPM loop will reduce the charge current, such that the total current for the load and the charge current equals the input current limit. This is done as soon as the voltage at SYS drops 100mV below the target voltage.

Second there is input voltage DPPM. For this, the input voltage to the charger/power path at pin AC is sensed to avoid the voltage from a USB port or dedicated charger to drop below a certain limit. This control loop will reduce the input current limit for pin AC as soon as the voltage at AC drops below 4.5V (typically). With Bits ACinputcurrent[1,0] set to 00 or 01, input voltage DPPM is enabled, with ACinputcurrent=10, input voltage DPPM is disabled.

### Layout Considerations

As for all switching power supplies, the layout is an important step in the design. Proper function of the device demands careful attention to PCB layout. Care must be taken in board layout to get the specified performance. If the layout is not carefully done, the regulators may show poor line and/or load regulation, and additional stability issues as well as EMI problems. It is critical to provide a low impedance ground path. Therefore, use wide and short traces for the main current paths. The input capacitors should be placed as close as possible to the IC pins as well as the inductor and output capacitor.

For TPS65721, connect the PGND pin of the device to the PowerPAD™ land of the PCB and connect the analog ground connection (GND) to the PGND at the PowerPAD™. Keep the common path to the GND pin, which returns the small signal components, and the high current of the output capacitors as short as possible to avoid ground noise. The FB line should be connected right to the output capacitor and routed away from noisy components and traces (for example, the L1 line). See the EVM users guide for details about the layout.

APPLICATION CIRCUITS

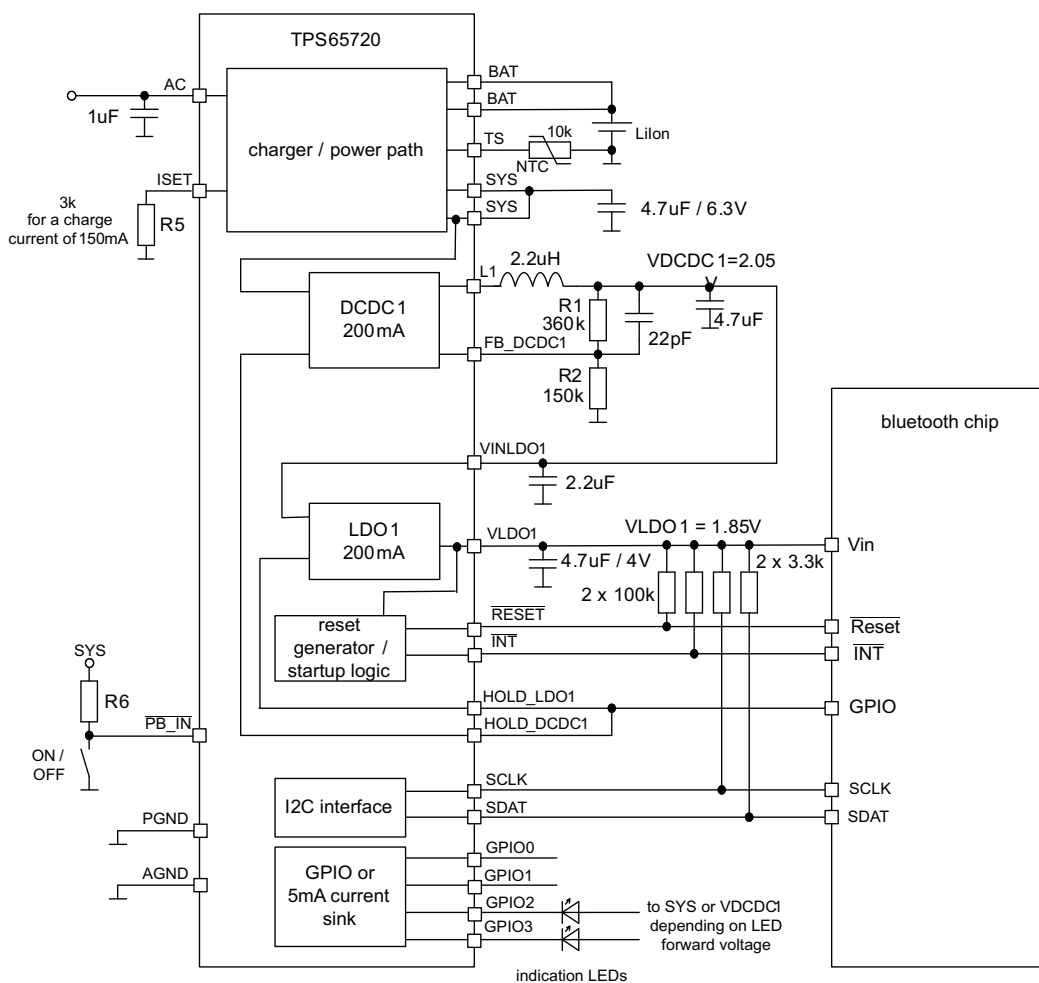

Figure 34. Typical Bluetooth Application

## PACKAGING INFORMATION

Orderable Device	Status (1)	Package Type	Package Drawing	Pins	Package Qty	Eco Plan (2)	Lead/Ball Finish	MSL Peak Temp (3)	Op Temp (°C)	Top-Side Markings (4)	Samples
TPS65720YFFR	ACTIVE	DSBGA	YFF	25	3000	Green (RoHS & no Sb/Br)	SNAGCU	Level-1-260C-UNLIM	-40 to 85	TPS65720	<a href="#">Samples</a>
TPS65720YFFT	ACTIVE	DSBGA	YFF	25	250	Green (RoHS & no Sb/Br)	SNAGCU	Level-1-260C-UNLIM	-40 to 85	TPS65720	<a href="#">Samples</a>
TPS65721RSNR	ACTIVE	QFN	RSN	32	3000	Green (RoHS & no Sb/Br)	CU NIPDAU	Level-2-260C-1 YEAR	-40 to 85	TPS 65721	<a href="#">Samples</a>
TPS65721RSNT	ACTIVE	QFN	RSN	32	250	Green (RoHS & no Sb/Br)	CU NIPDAU	Level-2-260C-1 YEAR	-40 to 85	TPS 65721	<a href="#">Samples</a>

(1) The marketing status values are defined as follows:

**ACTIVE:** Product device recommended for new designs.

**LIFEBUY:** TI has announced that the device will be discontinued, and a lifetime-buy period is in effect.

**NRND:** Not recommended for new designs. Device is in production to support existing customers, but TI does not recommend using this part in a new design.

**PREVIEW:** Device has been announced but is not in production. Samples may or may not be available.

**OBSOLETE:** TI has discontinued the production of the device.

(2) Eco Plan - The planned eco-friendly classification: Pb-Free (RoHS), Pb-Free (RoHS Exempt), or Green (RoHS & no Sb/Br) - please check <http://www.ti.com/productcontent> for the latest availability information and additional product content details.

**TBD:** The Pb-Free/Green conversion plan has not been defined.

**Pb-Free (RoHS):** TI's terms "Lead-Free" or "Pb-Free" mean semiconductor products that are compatible with the current RoHS requirements for all 6 substances, including the requirement that lead not exceed 0.1% by weight in homogeneous materials. Where designed to be soldered at high temperatures, TI Pb-Free products are suitable for use in specified lead-free processes.

**Pb-Free (RoHS Exempt):** This component has a RoHS exemption for either 1) lead-based flip-chip solder bumps used between the die and package, or 2) lead-based die adhesive used between the die and leadframe. The component is otherwise considered Pb-Free (RoHS compatible) as defined above.

**Green (RoHS & no Sb/Br):** TI defines "Green" to mean Pb-Free (RoHS compatible), and free of Bromine (Br) and Antimony (Sb) based flame retardants (Br or Sb do not exceed 0.1% by weight in homogeneous material)

(3) MSL, Peak Temp. -- The Moisture Sensitivity Level rating according to the JEDEC industry standard classifications, and peak solder temperature.

(4) Only one of markings shown within the brackets will appear on the physical device.

**Important Information and Disclaimer:** The information provided on this page represents TI's knowledge and belief as of the date that it is provided. TI bases its knowledge and belief on information provided by third parties, and makes no representation or warranty as to the accuracy of such information. Efforts are underway to better integrate information from third parties. TI has taken and continues to take reasonable steps to provide representative and accurate information but may not have conducted destructive testing or chemical analysis on incoming materials and chemicals. TI and TI suppliers consider certain information to be proprietary, and thus CAS numbers and other limited information may not be available for release.

In no event shall TI's liability arising out of such information exceed the total purchase price of the TI part(s) at issue in this document sold by TI to Customer on an annual basis.





**TAPE AND REEL INFORMATION**

**QUADRANT ASSIGNMENTS FOR PIN 1 ORIENTATION IN TAPE**

\*All dimensions are nominal

Device	Package Type	Package Drawing	Pins	SPQ	Reel Diameter (mm)	Reel Width W1 (mm)	A0 (mm)	B0 (mm)	K0 (mm)	P1 (mm)	W (mm)	Pin1 Quadrant
TPS65720YFFT	DSBGA	YFF	25	250	180.0	8.4	2.38	2.4	0.8	4.0	8.0	Q1
TPS65721RSNR	QFN	RSN	32	3000	330.0	12.4	4.25	4.25	1.15	8.0	12.0	Q2
TPS65721RSNT	QFN	RSN	32	250	180.0	12.4	4.25	4.25	1.15	8.0	12.0	Q2

**TAPE AND REEL BOX DIMENSIONS**

\*All dimensions are nominal

Device	Package Type	Package Drawing	Pins	SPQ	Length (mm)	Width (mm)	Height (mm)
TPS65720YFFT	DSBGA	YFF	25	250	210.0	185.0	35.0
TPS65721RSNR	QFN	RSN	32	3000	367.0	367.0	35.0
TPS65721RSNT	QFN	RSN	32	250	210.0	185.0	35.0

RSN (S-PWQFN-N32)

PLASTIC QUAD FLATPACK NO-LEAD

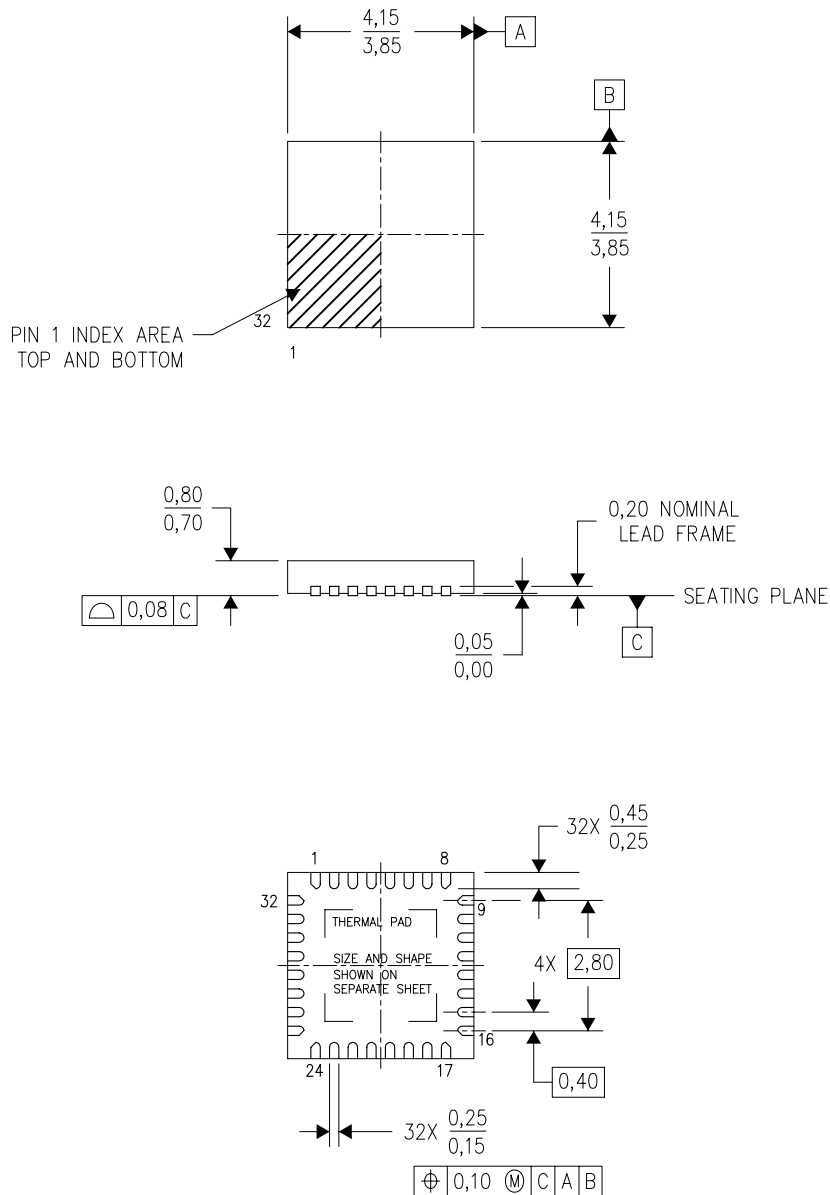

4207561/C 08/11

- NOTES:
- All linear dimensions are in millimeters. Dimensioning and tolerancing per ASME Y14.5M-1994.
  - This drawing is subject to change without notice.
  - QFN (Quad Flatpack No-Lead) Package configuration.
  - The package thermal pad must be soldered to the board for thermal and mechanical performance.
  - See the additional figure in the Product Data Sheet for details regarding the exposed thermal pad features and dimensions.

## THERMAL PAD MECHANICAL DATA

RSN (S-PWQFN-N32)

PLASTIC QUAD FLATPACK NO-LEAD

### THERMAL INFORMATION

This package incorporates an exposed thermal pad that is designed to be attached directly to an external heatsink. The thermal pad must be soldered directly to the printed circuit board (PCB). After soldering, the PCB can be used as a heatsink. In addition, through the use of thermal vias, the thermal pad can be attached directly to the appropriate copper plane shown in the electrical schematic for the device, or alternatively, can be attached to a special heatsink structure designed into the PCB. This design optimizes the heat transfer from the integrated circuit (IC).

For information on the Quad Flatpack No-Lead (QFN) package and its advantages, refer to Application Report, QFN/SON PCB Attachment, Texas Instruments Literature No. SLUA271. This document is available at [www.ti.com](http://www.ti.com).

The exposed thermal pad dimensions for this package are shown in the following illustration.

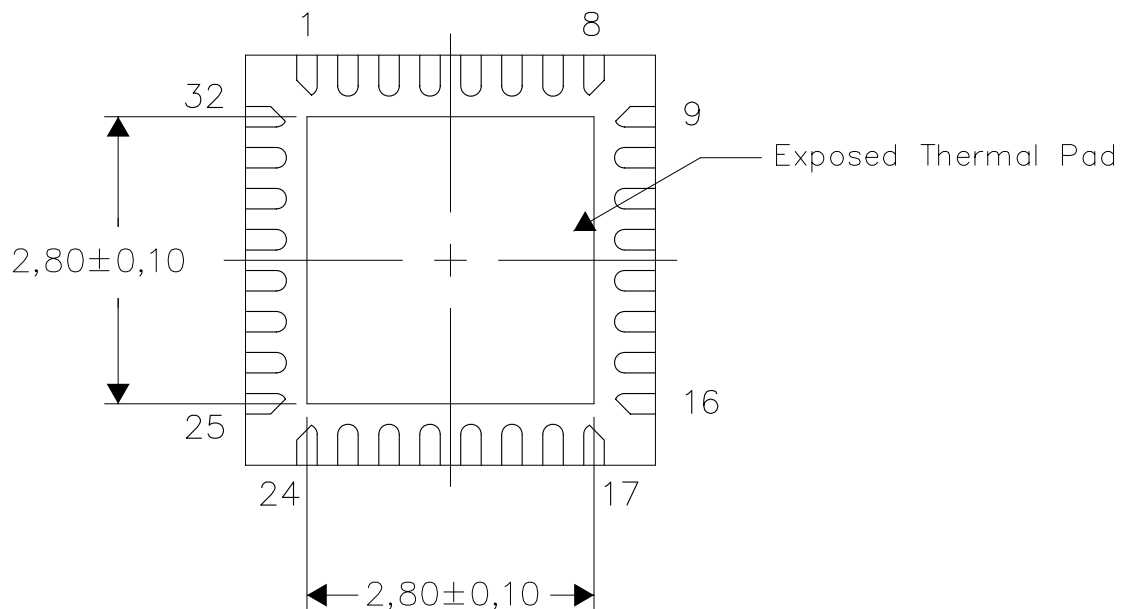

Bottom View

Exposed Thermal Pad Dimensions

4209775-2/E 09/11

NOTE: All linear dimensions are in millimeters

RSN (S-PWQFN-N32)

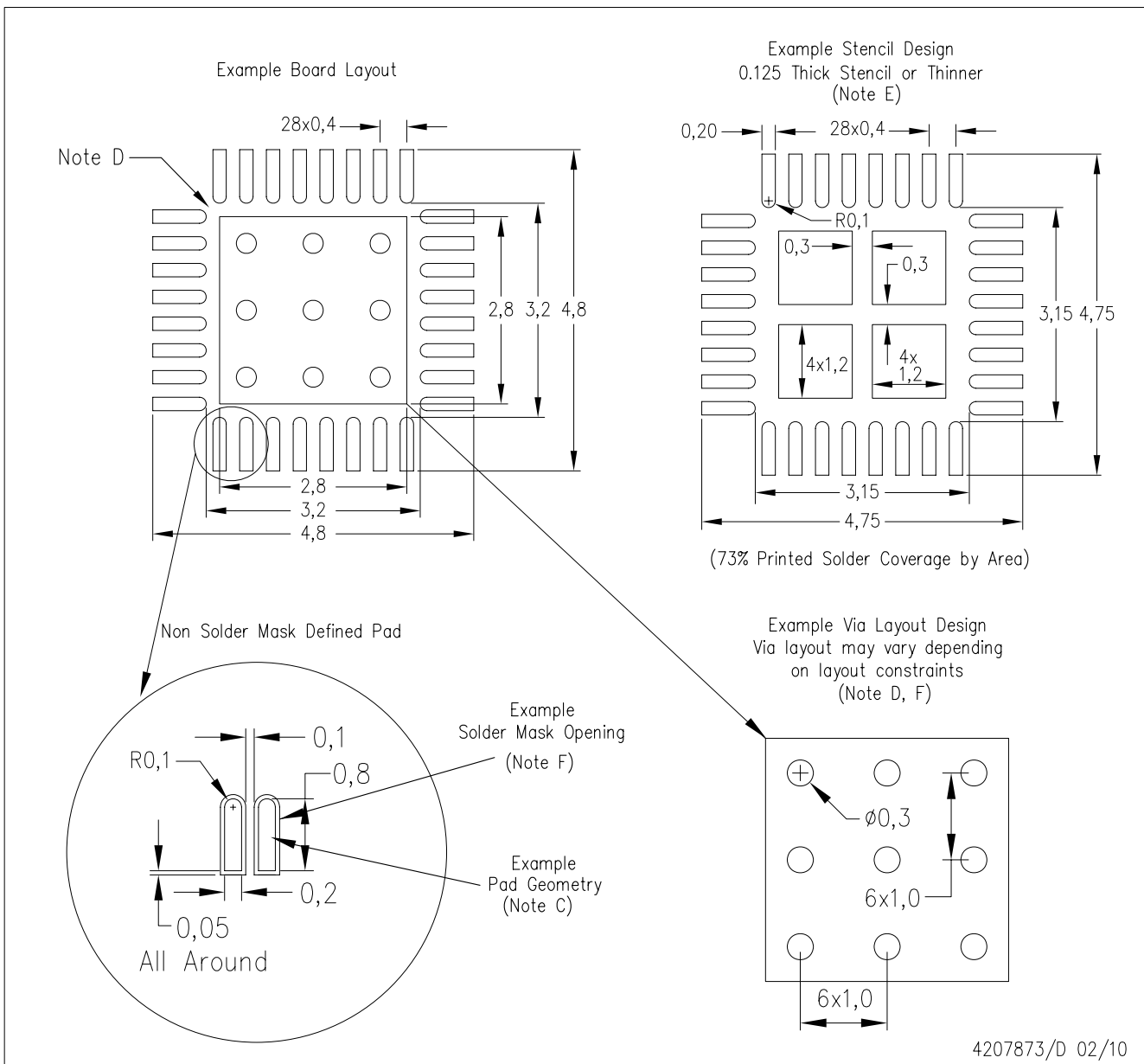

- NOTES:
- A. All linear dimensions are in millimeters.
  - B. This drawing is subject to change without notice.
  - C. Publication IPC-7351 is recommended for alternate designs.
  - D. This package is designed to be soldered to a thermal pad on the board. Refer to Application Note, Quad Flat-Pack Packages, Texas Instruments Literature No. SLUA271, and also the Product Data Sheets for specific thermal information, via requirements, and recommended board layout. These documents are available at [www.ti.com](http://www.ti.com) <<http://www.ti.com>>.
  - E. Laser cutting apertures with trapezoidal walls and also rounding corners will offer better paste release. Customers should contact their board assembly site for stencil design recommendations. Refer to IPC 7525 for stencil design considerations.
  - F. Customers should contact their board fabrication site for recommended solder mask tolerances and via tenting recommendations for vias placed in the thermal pad.

# MECHANICAL DATA

YFF (S-XBGA-N25)

DIE-SIZE BALL GRID ARRAY

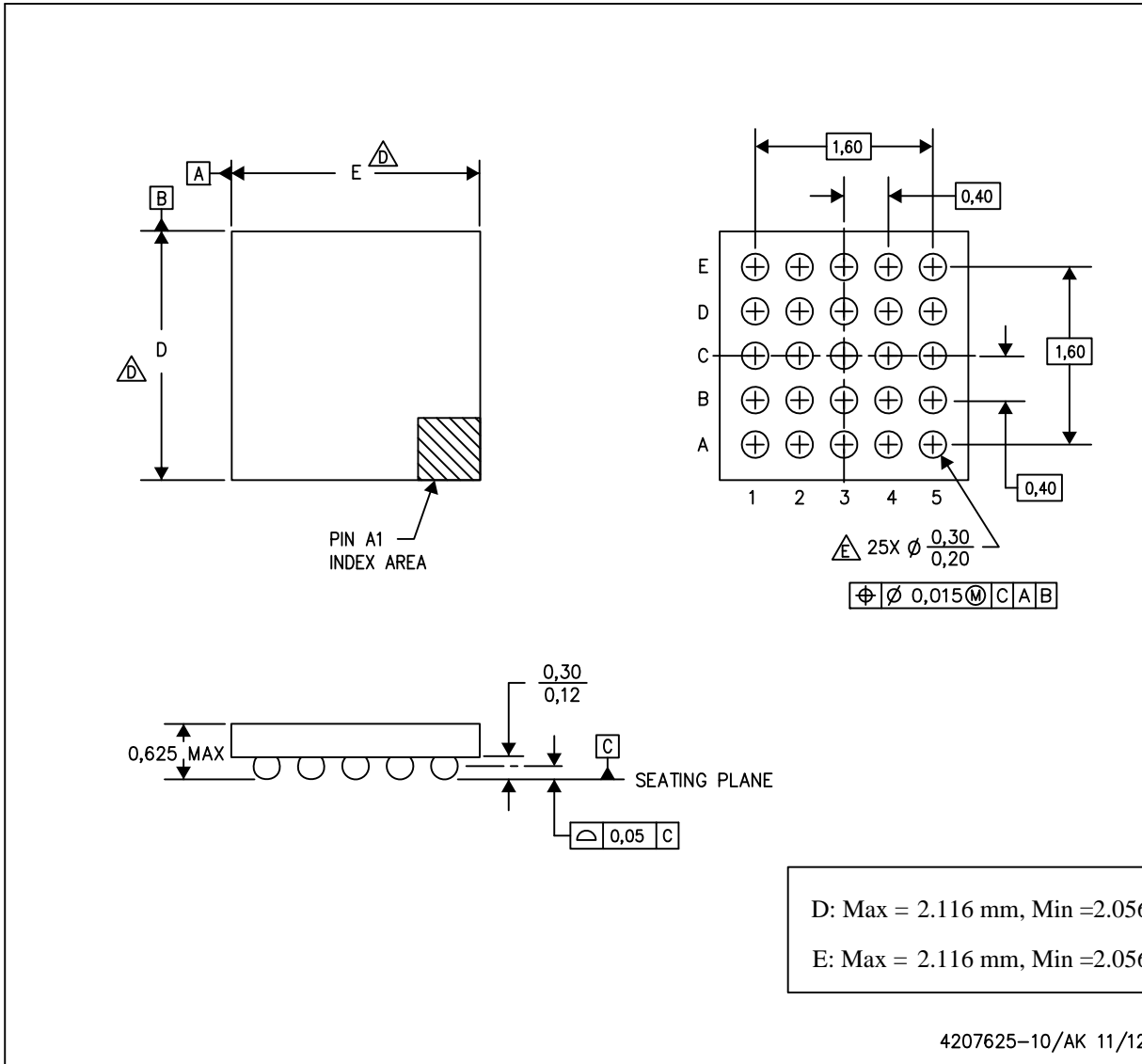

- NOTES:
- A. All linear dimensions are in millimeters. Dimensioning and tolerancing per ASME Y14.5M-1994.
  - B. This drawing is subject to change without notice.
  - C. NanoFree™ package configuration.
  - The package size (Dimension D and E) of a particular device is specified in the device Product Data Sheet version of this drawing, in case it cannot be found in the product data sheet please contact a local TI representative.
  - E. Reference Product Data Sheet for array population.  
5 x 5 matrix pattern is shown for illustration only.
  - F. This package contains Pb-free balls.

NanoFree is a trademark of Texas Instruments

## IMPORTANT NOTICE

Texas Instruments Incorporated and its subsidiaries (TI) reserve the right to make corrections, enhancements, improvements and other changes to its semiconductor products and services per JESD46, latest issue, and to discontinue any product or service per JESD48, latest issue. Buyers should obtain the latest relevant information before placing orders and should verify that such information is current and complete. All semiconductor products (also referred to herein as "components") are sold subject to TI's terms and conditions of sale supplied at the time of order acknowledgment.

TI warrants performance of its components to the specifications applicable at the time of sale, in accordance with the warranty in TI's terms and conditions of sale of semiconductor products. Testing and other quality control techniques are used to the extent TI deems necessary to support this warranty. Except where mandated by applicable law, testing of all parameters of each component is not necessarily performed.

TI assumes no liability for applications assistance or the design of Buyers' products. Buyers are responsible for their products and applications using TI components. To minimize the risks associated with Buyers' products and applications, Buyers should provide adequate design and operating safeguards.

TI does not warrant or represent that any license, either express or implied, is granted under any patent right, copyright, mask work right, or other intellectual property right relating to any combination, machine, or process in which TI components or services are used. Information published by TI regarding third-party products or services does not constitute a license to use such products or services or a warranty or endorsement thereof. Use of such information may require a license from a third party under the patents or other intellectual property of the third party, or a license from TI under the patents or other intellectual property of TI.

Reproduction of significant portions of TI information in TI data books or data sheets is permissible only if reproduction is without alteration and is accompanied by all associated warranties, conditions, limitations, and notices. TI is not responsible or liable for such altered documentation. Information of third parties may be subject to additional restrictions.

Resale of TI components or services with statements different from or beyond the parameters stated by TI for that component or service voids all express and any implied warranties for the associated TI component or service and is an unfair and deceptive business practice. TI is not responsible or liable for any such statements.

Buyer acknowledges and agrees that it is solely responsible for compliance with all legal, regulatory and safety-related requirements concerning its products, and any use of TI components in its applications, notwithstanding any applications-related information or support that may be provided by TI. Buyer represents and agrees that it has all the necessary expertise to create and implement safeguards which anticipate dangerous consequences of failures, monitor failures and their consequences, lessen the likelihood of failures that might cause harm and take appropriate remedial actions. Buyer will fully indemnify TI and its representatives against any damages arising out of the use of any TI components in safety-critical applications.

In some cases, TI components may be promoted specifically to facilitate safety-related applications. With such components, TI's goal is to help enable customers to design and create their own end-product solutions that meet applicable functional safety standards and requirements. Nonetheless, such components are subject to these terms.

No TI components are authorized for use in FDA Class III (or similar life-critical medical equipment) unless authorized officers of the parties have executed a special agreement specifically governing such use.

Only those TI components which TI has specifically designated as military grade or "enhanced plastic" are designed and intended for use in military/aerospace applications or environments. Buyer acknowledges and agrees that any military or aerospace use of TI components which have **not** been so designated is solely at the Buyer's risk, and that Buyer is solely responsible for compliance with all legal and regulatory requirements in connection with such use.

TI has specifically designated certain components as meeting ISO/TS16949 requirements, mainly for automotive use. In any case of use of non-designated products, TI will not be responsible for any failure to meet ISO/TS16949.

### Products

Audio	<a href="http://www.ti.com/audio">www.ti.com/audio</a>
Amplifiers	<a href="http://amplifier.ti.com">amplifier.ti.com</a>
Data Converters	<a href="http://dataconverter.ti.com">dataconverter.ti.com</a>
DLP® Products	<a href="http://www.dlp.com">www.dlp.com</a>
DSP	<a href="http://dsp.ti.com">dsp.ti.com</a>
Clocks and Timers	<a href="http://www.ti.com/clocks">www.ti.com/clocks</a>
Interface	<a href="http://interface.ti.com">interface.ti.com</a>
Logic	<a href="http://logic.ti.com">logic.ti.com</a>
Power Mgmt	<a href="http://power.ti.com">power.ti.com</a>
Microcontrollers	<a href="http://microcontroller.ti.com">microcontroller.ti.com</a>
RFID	<a href="http://www.ti-rfid.com">www.ti-rfid.com</a>
OMAP Applications Processors	<a href="http://www.ti.com/omap">www.ti.com/omap</a>
Wireless Connectivity	<a href="http://www.ti.com/wirelessconnectivity">www.ti.com/wirelessconnectivity</a>

### Applications

Automotive and Transportation	<a href="http://www.ti.com/automotive">www.ti.com/automotive</a>
Communications and Telecom	<a href="http://www.ti.com/communications">www.ti.com/communications</a>
Computers and Peripherals	<a href="http://www.ti.com/computers">www.ti.com/computers</a>
Consumer Electronics	<a href="http://www.ti.com/consumer-apps">www.ti.com/consumer-apps</a>
Energy and Lighting	<a href="http://www.ti.com/energy">www.ti.com/energy</a>
Industrial	<a href="http://www.ti.com/industrial">www.ti.com/industrial</a>
Medical	<a href="http://www.ti.com/medical">www.ti.com/medical</a>
Security	<a href="http://www.ti.com/security">www.ti.com/security</a>
Space, Avionics and Defense	<a href="http://www.ti.com/space-avionics-defense">www.ti.com/space-avionics-defense</a>
Video and Imaging	<a href="http://www.ti.com/video">www.ti.com/video</a>

### TI E2E Community

[e2e.ti.com](http://e2e.ti.com)