

DESCRIPTION

The MP3378E is a one-chip solution specially designed for monitor applications. The MP3378E includes a step-up WLED controller with four current channels for backlighting, and a high-efficiency buck converter for internal bus voltage or standby power.

The 4-string WLED controller drives an external MOSFET to boost up the output voltage from the input supply. It regulates the current in each LED string to the programmed value set by an external current setting resistor. It supports both analog and PWM dimming independently to meet special dimming mode requests. Full protection features for the WLED controller include OCP, OTP, UVP, OVP, LED short/open protection, and inductor/diode short protection.

The high-efficiency buck converter operates in the current mode operation with a built-in MOSFET and a built-in synchronous rectifier. It offers a very compact solution to achieve excellent load and line regulation. Full protection features for the buck converter include OCP and thermal shutdown.

The MP3378E is available in a TSSOP-28 EP package.

FEATURES

WLED Controller:

- 4-String, Max 350mA/String, WLED Controller
- Up to 24V Input Voltage Range
- 2.5% Current Matching Accuracy
- Programmable Switching Frequency
- PWM and Analog Dimming Mode
- LED Open and Short Protection
- Programmable Over-Voltage Protection
- Recoverable Thermal Shutdown Protection
- Over-Current Protection
- Over-Temperature Protection
- Inductor/Diode Short Protection

Buck Converter:

- 144mΩ/80mΩ Low $R_{DS(ON)}$ Internal Power MOSFETs
- Low Quiescent Current
- Fixed 235kHz Switching Frequency
- Frequency Sync from 250kHz to 2MHz
- External Clock
- Internal Soft Start
- OCP and Hiccup Mode
- Over-Temperature Protection
- Output Adjustable from 0.8V

APPLICATIONS

- Desktop LCD Flat Panel Displays
- Flat Panel Video Displays
- 2D/3D LCD TVs and Monitors

All MPS parts are lead-free, halogen-free, and adhere to the RoHS directive. For MPS green status, please visit the MPS website under Quality Assurance.

"MPS" and "The Future of Analog IC Technology" are registered trademarks of Monolithic Power Systems, Inc.

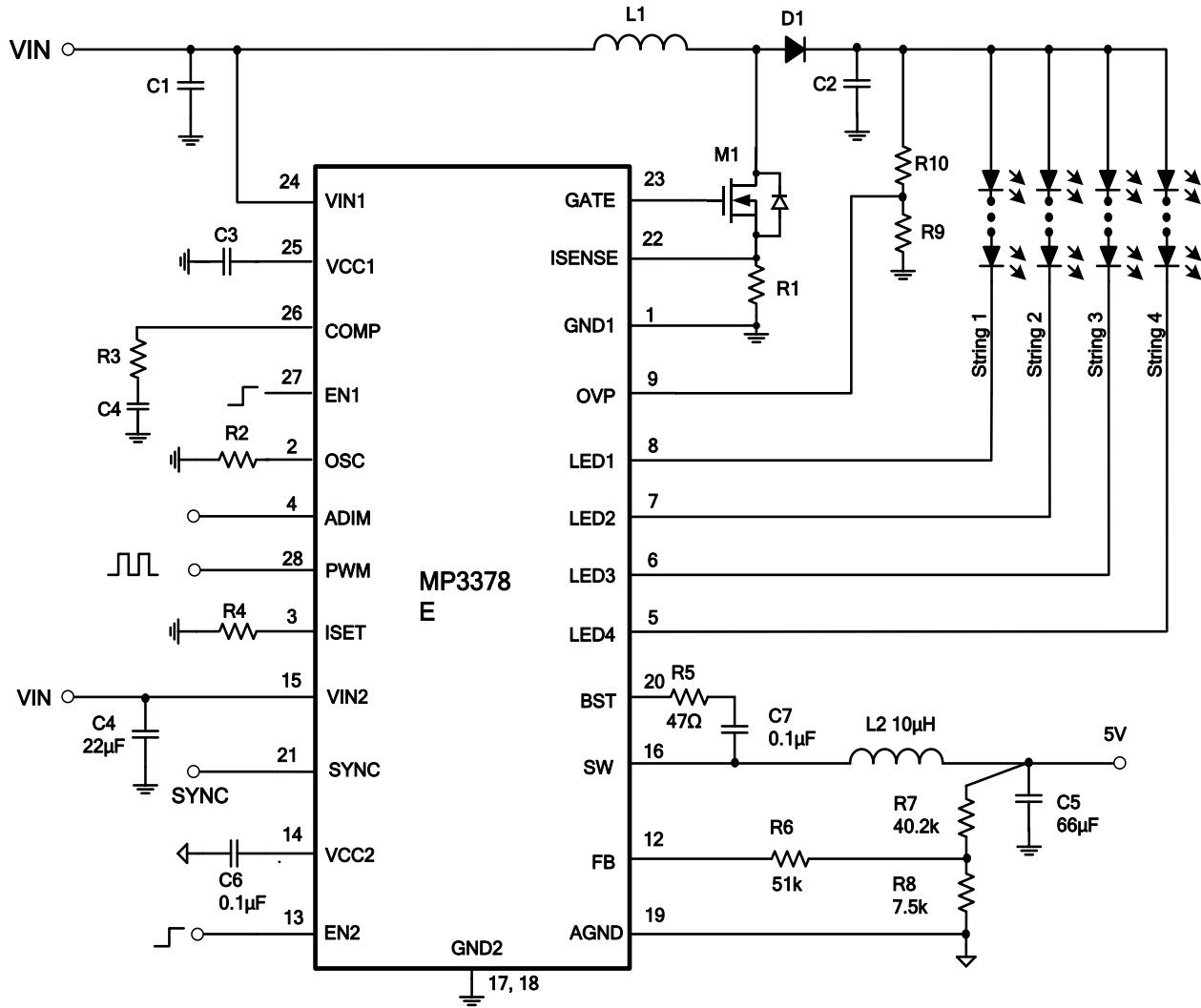
TYPICAL APPLICATION

ORDERING INFORMATION

Part Number	Package	Top Marking
MP3378EGF	TSSOP-28 EP	See Below

* For Tape & Reel, add suffix -Z (e.g. MP3378EGF-Z)

TOP MARKING

MPSYYWW

MP3378E

LLLLLLLLL

MP3378E: Product code of MP3378EGF
 MPS: MPS prefix
 YY: Year code
 WW: Week code
 LLLLLLLLL: Lot number

PACKAGE REFERENCE

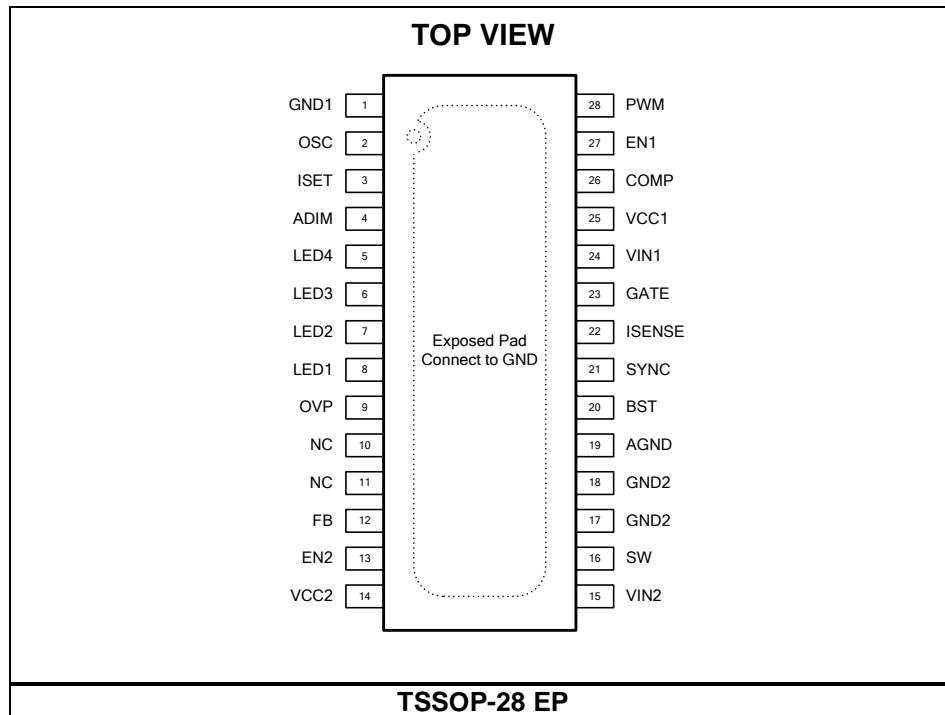

ABSOLUTE MAXIMUM RATINGS ⁽¹⁾
WLED Controller

V_{IN1}	-0.3V to +28V
V_{LED1} to V_{LED4}	-1V to +55V
V_{GATE} , V_{CC1} , V_{ISENSE}	-0.3V to +6.5V
All other pins.....	-0.3V to VCC1

Buck Converter

V_{IN2} , V_{SW}	-0.3V to 28V
V_{BST}	$V_{SW}+6V$
All other pins.....	-0.3V to 6V

 Continuous power dissipation ($T_A = 25^\circ\text{C}$) ⁽²⁾

TSSOP-28 EP	3.9W
Junction Temperature	150°C
Lead Temperature	260°C

Recommended Operating Conditions ⁽³⁾

Supply voltage (V_{IN1} , V_{IN2})	5V to 24V
Operating junction temp. (T_J) ..	-40°C to +125°C

Thermal Resistance ⁽⁴⁾

	θ_{JA}	θ_{JC}
TSSOP-28 EP.....	32.....	6....

NOTES:

- 1) Exceeding these ratings may damage the device. The voltage is measured with a 20MHz bandwidth limited oscilloscope.
- 2) The maximum allowable power dissipation is a function of the maximum junction temperature T_J (MAX), the junction-to-ambient thermal resistance θ_{JA} , and the ambient temperature T_A . The maximum allowable continuous power dissipation at any ambient temperature is calculated by P_D (MAX) = $(T_J$ (MAX)- T_A)/ θ_{JA} . Exceeding the maximum allowable power dissipation produces an excessive die temperature, causing the regulator to go into thermal shutdown. Internal thermal shutdown circuitry protects the device from permanent damage.
- 3) The device is not guaranteed to function outside of its operating conditions.
- 4) Measured on JESD51-7, 4-layer PCB.

ELECTRICAL CHARACTERISTICS ⁽⁵⁾
 $V_{IN1} = V_{IN2} = 12V$, $V_{EN1} = V_{EN2} = 5V$, $T_A = 25^\circ C$, unless otherwise noted.

Parameters	Symbol	Condition	Min	Typ	Max	Units
WLED Controller Section						
Supply current (quiescent)	I_{Q1}	$V_{IN1} = 12V$, $V_{EN1} = 5V$, no load without switching, buck disabled	1.2	1.35	1.5	mA
Supply current (shutdown)	I_{ST1}	$V_{EN1} = 0V$, $V_{IN} = 12V$, buck disabled			1	μA
LDO output voltage	V_{CC1}	$V_{EN1} = 5V$, $7V < V_{IN1} < 28V$, $0 < I_{VCC1} < 10mA$	5.4	6	6.6	V
VCC1 UVLO threshold	V_{CC1_UVLO}	Rising edge	3.6	4	4.4	V
VCC1 UVLO hysteresis				200		mV
EN1 high voltage	V_{EN1_HIGH}	V_{EN1} rising	1.8			V
EN1 low voltage	V_{EN1_LOW}	V_{EN1} falling			0.6	V
Step-Up Converter						
Gate driver impedance (sourcing)		$V_{CC1} = 6V$, $V_{GATE} = 6V$		4.1	7	Ω
Gate driver impedance (sinking)		$V_{CC1} = 6V$, $I_{GATE} = 10mA$		3	5	Ω
Switching frequency	f_{SW1}	$R_{OSC} = 115k\Omega$	470	530	590	kHz
		$R_{OSC} = 374k\Omega$	150	180	210	kHz
OSC voltage	V_{OSC}		1.20	1.23	1.26	V
Maximum duty cycle	D_{MAX1}			93		%
Cycle-by-cycle ISENSE current limit		Max duty cycle	145	180	230	mV
COMP source current limit	I_{COMP_SOLI}	$1V < COMP < 1.9V$		70		μA
COMP sink current limit	I_{COMP_SILI}	$1V < COMP < 1.9V$		17		μA
COMP transconductance	G_{COMP}	$\Delta I_{COMP} = \pm 10\mu A$		440		$\mu A/V$
Current Dimming						
PWM input low threshold	V_{PWM_LO}	V_{PWM} falling			0.75	V
PWM input high threshold	V_{PWM_HI}	V_{PWM} rising	1.25			V
Analog dimming input low threshold			0.38	0.41	0.44	V
Analog dimming input high threshold			1.44	1.49	1.54	V
LED Current Regulation						
ISET voltage	V_{ISET}		1.20	1.225	1.25	V
LEDX average current	I_{LED}	$R_{ISET} = 30.5k\Omega$	31.4	33	34.2	mA
Current matching ⁽⁵⁾		$I_{LED} = 32mA$			2.5	%
VCC max current limit	I_{CC1_Limit}		50	75	100	mA
LED FET resistance	R_{LED}	$I_{LED} = 10mA$		1.7		Ω
LEDX regulation voltage	V_{LEDX}	$I_{LED} = 330mA$		800		mV
		$I_{LED} = 60mA$		260		mV

ELECTRICAL CHARACTERISTICS (continued)
 $V_{IN1} = V_{IN2} = 12V$, $V_{EN1} = V_{EN2} = 5V$, $T_A = 25^\circ C$, unless otherwise noted.

Parameters	Symbol	Condition	Min	Typ	Max	Units
Protection						
OVP (over-voltage protection) threshold	V_{OVP_OV}	Rising edge	1.20	1.23	1.26	V
OVP (over-voltage protection) threshold hysteresis	V_{OVP_HYS}	OVP hysteresis		80		mV
OVP UVLO threshold	V_{OVP_UV}	Step-up converter fails	33	75	115	mV
LEDX UVLO threshold	V_{LEDX_UV}		120	190	260	mV
LEDX over-voltage threshold	V_{LEDX_OV}		5.8	6.3	6.8	V
LED short fault cycles	T_{LED_OV}			4096		
Latch-off current limit	V_{LMT}		600	660	720	mV
Thermal protection threshold	T_{ST}			150		$^\circ C$
Thermal protection hysteresis				25		$^\circ C$
Buck Converter Section						
Supply current (quiescent)	I_{Q2}	$V_{FB} = 1V$, WLED controller disabled	150	200	250	μA
Supply current (shutdown)	I_{ST2}	$V_{EN2} = 0V$, WLED controller disabled			10	μA
VIN2 under-voltage lockout threshold	V_{IN2_UVLO}	Rising edge	3.7	3.9	4.1	V
VIN2 under-voltage lockout threshold hysteresis			550	650	750	mV
VCC2 regulator	V_{CC2}		4.65	4.9	5.15	V
VCC2 load regulation		ICC2 = 5mA	0	1	3	%
EN2 high threshold	V_{EN2_HI}	EN2 rising threshold	1.8			V
EN2 low threshold	V_{EN2_LO}	EN2 falling threshold			0.6	V
HS switch-on resistance	HS_{RDS-ON}	$V_{BST-SW} = 5V$		144		m Ω
LS switch-on resistance	LS_{RDS-ON}	$V_{CC2} = 5V$		80		m Ω
Current limit	I_{LIMIT}	Duty cycle = 40%	4.8	6	7.2	A
Oscillator frequency	f_{SW2}	$V_{FB} = 750mV$	190	235	280	kHz
Foldback frequency	f_{FB}	$V_{FB} = 200mV$		0.5		f_{SW2}
Maximum duty cycle	D_{MAX2}	$V_{FB} = 750mV$	90	95		%
Minimum on time ⁽⁵⁾	T_{ON_MIN}			80		ns
Sync frequency range	f_{SYNC}		0.25		2	MHz
Feedback voltage	V_{FB}	$T_A = 25^\circ C$	779	791	803	mV
Feedback current	I_{FB}	$V_{FB} = 820mV$		10	50	nA
Soft-start period	T_{SS}	10% to 90%	0.8	1.5	2.2	ms

ELECTRICAL CHARACTERISTICS *(continued)*
 $V_{IN1} = V_{IN2} = 12V$, $V_{EN1} = V_{EN2} = 5V$, $T_A = 25^{\circ}C$, unless otherwise noted.

Parameters	Symbol	Condition	Min	Typ	Max	Units
SYNC high threshold	V_{SYNC_HI}		1.8			V
SYNC low threshold	V_{SYNC_LO}				0.6	V
Thermal shutdown				150		$^{\circ}C$
Thermal hysteresis				20		$^{\circ}C$

NOTE:

5) Matching is defined as the difference between the maximum to minimum current divided by 2 times the average currents.

TYPICAL PERFORMANCE CHARACTERISTICS

WLED Controller Section:

$V_{IN} = 16V$, 10 LEDs in series, 4 strings parallel, 120mA/string, $T_A = 25^\circ C$, unless otherwise noted.

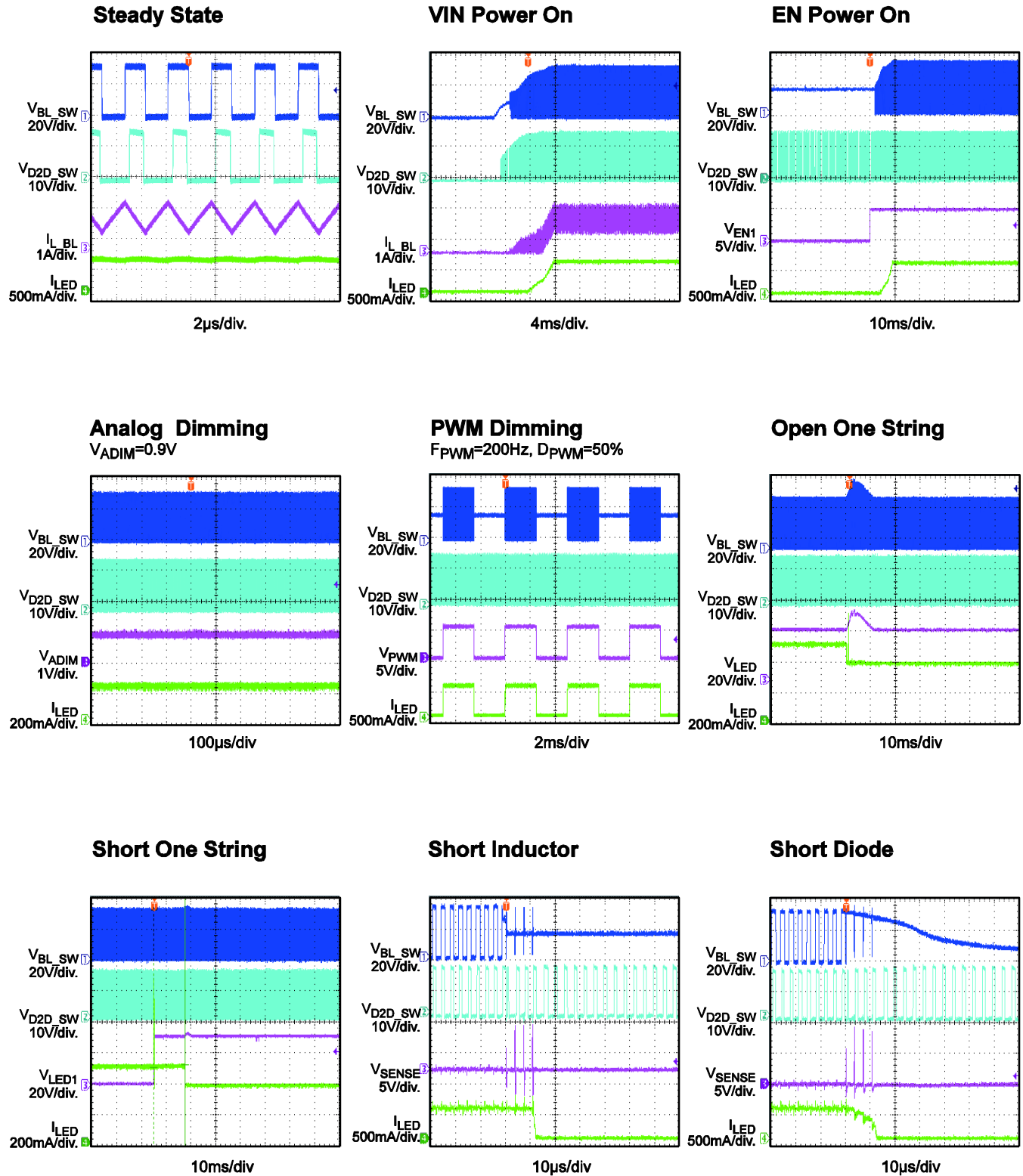

TYPICAL PERFORMANCE CHARACTERISTICS

Buck Converter Section:

$V_{IN} = 16V$, $V_{OUT} = 5V$, $L_2 = 10\mu H$, $T_A = 25^\circ C$, unless otherwise noted.

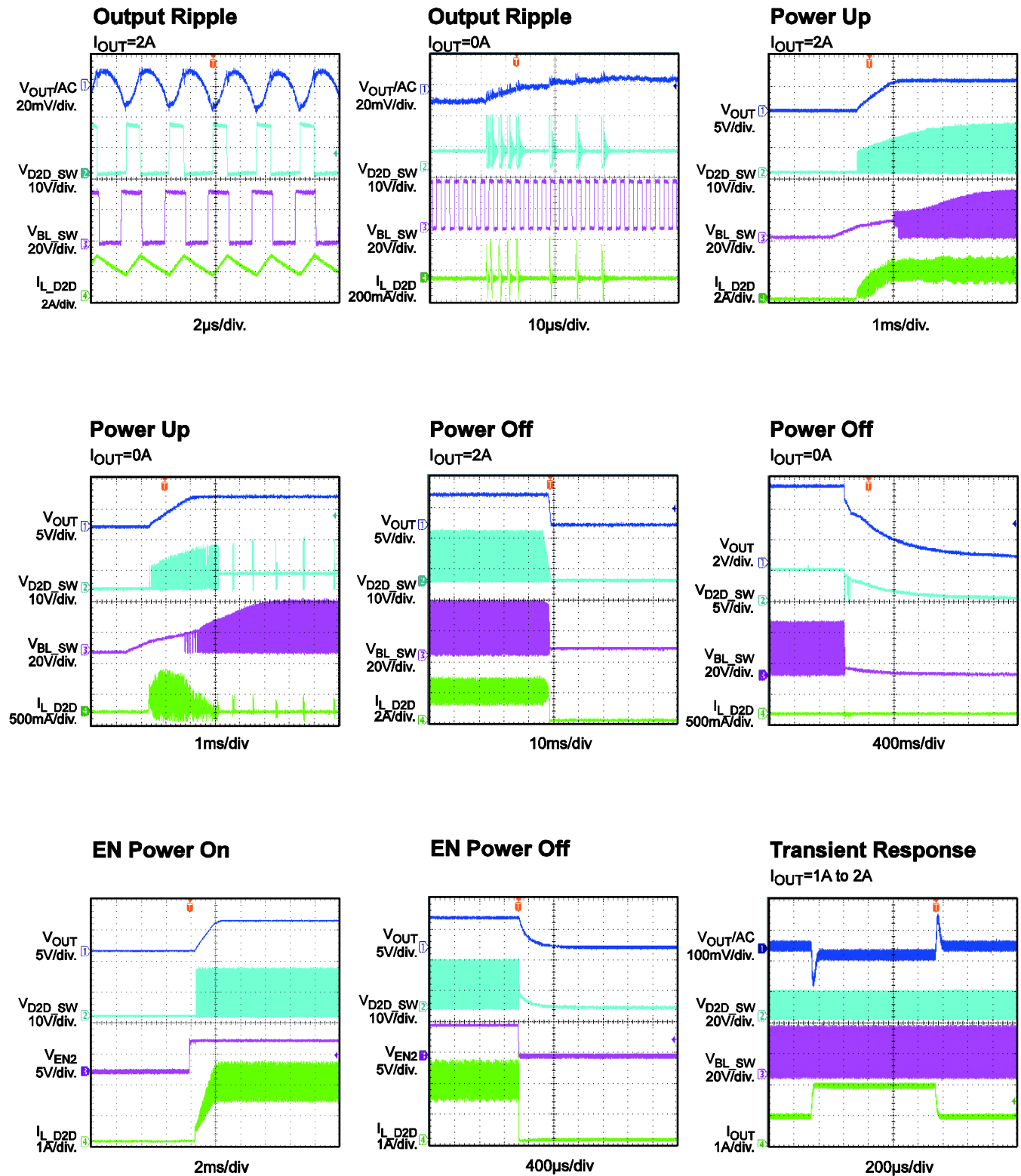

PIN FUNCTIONS

Pin #	Name	Description
1	GND1	Ground for WLED controller.
2	OSC	Switching frequency set. Connect a resistor between OSC and GND to set the step-up converter switching frequency. The voltage at OSC is regulated to 1.23V. The clock frequency is proportional to the current sourced from OSC.
3	ISET	LED current set. Tie a current-setting resistor from ISET to ground to program the current in each LED string. The ISET voltage is regulated to 1.225V. The LED current is proportional to the current through the ISET resistor.
4	ADIM	Input for analog brightness control. The LED current amplitude is determined by ADIM, and the input signal can be either a PWM signal or a DC voltage signal. An internal RC filter (10MΩ resistor and 100pF capacitor) is integrated into ADIM. If a PWM signal is applied to ADIM, a >20kHz frequency is recommended for better PWM signal filtering performance to ensure that the amplitude voltage is higher than 1.5V, and the low-level voltage is less than 0.4V. For a DC signal input, apply a DC input signal ranging from 0.41V to 1.49V to set the LED current linearly from minimum to full scale. Internally pull to GND if ADIM is floated.
5	LED4	LED string 4 current input. LED4 is the open-drain output of an internal dimming control switch. Connect the LED string 4 cathode to LED4.
6	LED3	LED string 3 current input. LED3 is the open-drain output of an internal dimming control switch. Connect the LED string 3 cathode to LED3.
7	LED2	LED string 2 current input. LED2 is the open-drain output of an internal dimming control switch. Connect the LED string 2 cathode to LED2.
8	LED1	LED string 1 current input. LED1 is the open-drain output of an internal dimming control switch. Connect the LED string 1 cathode to LED1.
9	OVP	Over-voltage protection input. Connect a resistor divider from the output to OVP to program the OVP threshold.
10, 11	NC	Not connected.
12	FB	Buck converter feedback. An external resistor divider from the output to AGND tapped to FB sets the output voltage. To prevent current-limit runaway during a short-circuit fault condition, the frequency foldback comparator lowers the oscillator frequency when the FB voltage is below 400mV.
13	EN2	Buck converter enable. Pull EN2 high to enable the buck converter.
14	VCC2	Bias supply for buck converter. Decouple with a 0.1μF-0.22μF capacitor. The capacitance should be no more than 0.22μF.
15	VIN2	Supply voltage input for buck converter. A ceramic capacitor is needed to decouple the input rail. Use a wide PCB trace to make the connection.
16	SW	Switch output for buck converter. Use a wide PCB trace to make the connection.
17, 18	GND2	Ground for buck converter.
19	AGND	Analog ground for buck converter.

PIN FUNCTIONS *(continued)*

Pin #	Name	Description
20	BST	Bootstrap for buck converter. A capacitor and a 47Ω resistor connected between SW and BST are required to form a floating supply across the high-side switch driver.
21	SYNC	Synchronization for buck converter. Apply a clock signal with a frequency higher than 250KHz. The frequency of the buck converter can be synchronized by an external clock. The internal clock's rising edge is synchronized to the external clock's falling edge.
22	ISENSE	Current sense input for WLED controller. During normal operation, ISENSE senses the voltage across the external inductor current-sensing resistor (R_{SENSE}) for peak-current-mode control and also limits the inductor current during every switching cycle.
23	GATE	Power switch gate output for WLED controller. GATE drives the external power N-channel MOSFET device.
24	VIN1	Supply input for WLED controller.
25	VCC1	Internal 6V linear regulator output for WLED controller. VCC1 provides a power supply for the external MOSFET switch gate driver and the internal control circuitry. Bypass VCC1 to GND with a ceramic capacitor.
26	COMP	Error amplifier output of WLED controller. Connect a capacitor and a resistor in series to make the boost converter loop stable.
27	EN1	Enable input for WLED controller.
28	PWM	Input signal for PWM brightness control. The PWM pin should be used for dimming and can not be used for turning on/off the WLED controller. Internally pull to GND if PWM is floated.

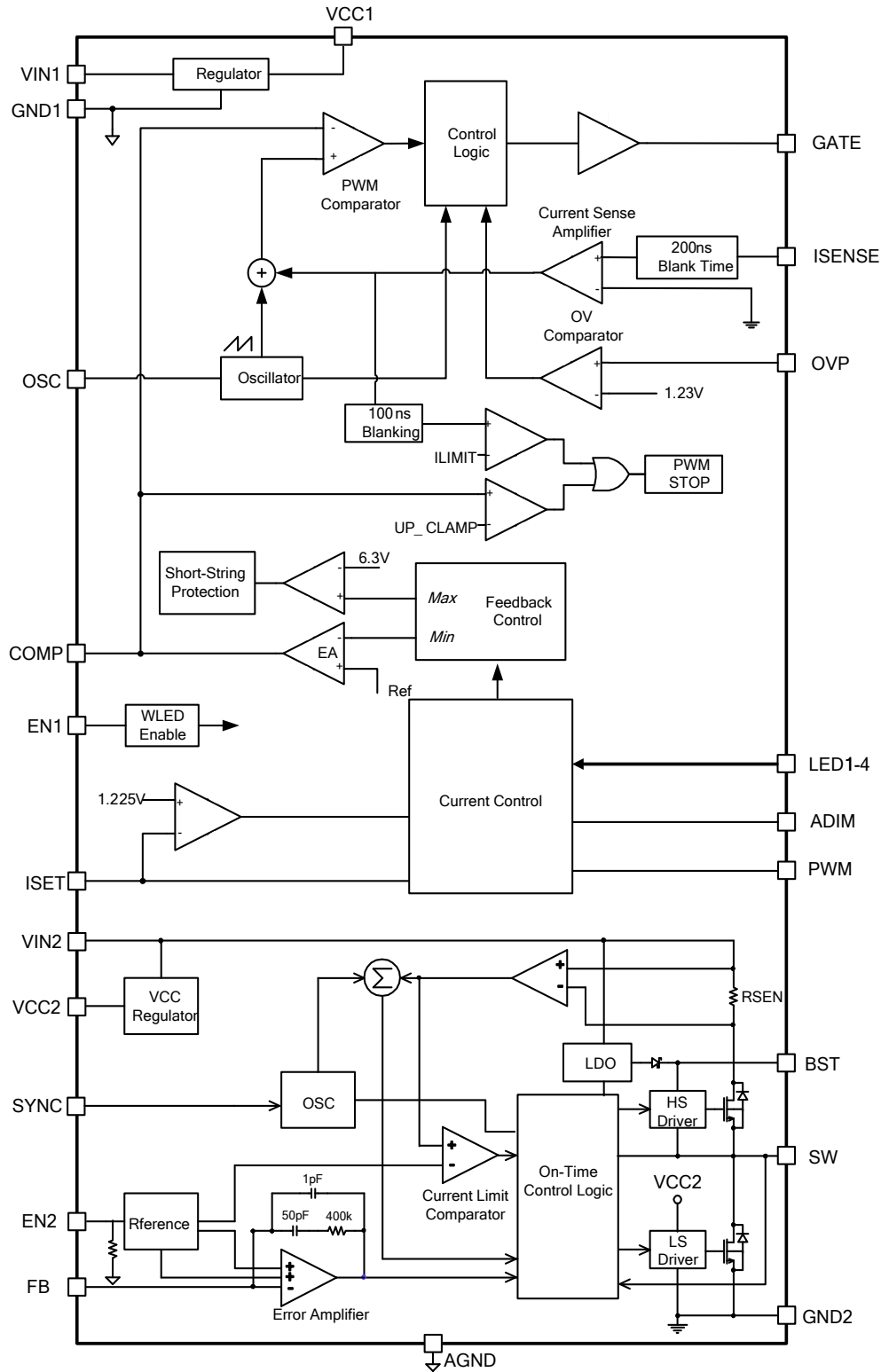
BLOCK DIAGRAM

Figure 1: Functional Block Diagram

OPERATION

WLED CONTROLLER SECTION:

The WLED controller employs a programmable, constant frequency, peak current mode, step-up converter with four channels that regulate current sources to drive an array of up to four strings of white LEDs.

Internal 6V Regulator

When VIN1 is greater than 6.5V, VCC1 outputs a 6V power supply to the external MOSFET switch gate driver and the internal control circuitry. The VCC1 voltage drops to 0V when the WLED controller shuts down.

System Start-Up

When enabled, the WLED controller checks the topology connection first. The WLED controller monitors the over-voltage protection (OVP) to see if the schottky diode is connected, or if the boost output is shorted to GND. An OVP voltage of less than 75mV will disable the WLED controller. Once all of the protection tests pass, the WLED controller then boosts the step-up converter with an internal soft start.

It is recommended that the enable signal occurs after the establishment of the input voltage and the PWM dimming signal during the start-up sequence to avoid a large inrush current. The PWM pin should be used for dimming function and can not be used for turning on/off the WLED controller.

If the PWM is used for turning on/off WLED controller in some applications, a resistor R_D is recommended to parallel with COMP pin as shown in figure 2. The recommended value for R_D is 1M Ω -10M Ω , considering the PWM frequency.

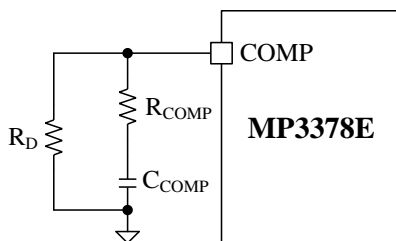

Figure 2 COMP Connection for turning on/off WLED Controller with PWM signal

Step-Up Converter

The converter operating frequency is programmable through an external resistor on OSC. The operating frequency is recommended between 300kHz to 500kHz. This helps optimize efficiency and the size of the external components.

At the beginning of each switching cycle, the internal clock turns on the external MOSFET (in normal operation, the minimum turn-on time is 200ns). A stabilizing ramp added to the output of the current sense amplifier prevents sub harmonic oscillations for duty cycles greater than 50 percent. This result is fed into the PWM comparator. When this resulted voltage reaches the output voltage of the error amplifier (V_{COMP}), the external MOSFET turns off.

The output voltage of the internal error amplifier is an amplified signal of the difference between the reference voltage and the feedback voltage.

Automatically, the converter chooses the lowest active LEDX voltage to provide a high enough bus voltage to power all the LED arrays.

If the feedback voltage drops below the reference, the output of the error amplifier increases. This results in more current flowing through the MOSFET, increasing the power delivered to the output. This forms a closed loop that regulates the output voltage.

Under light-load operation, especially in the case of $V_{OUT1} \approx V_{IN1}$, the converter runs in pulse-skipping mode, where the MOSFET turns on for a minimum on time of approximately 200ns before the converter discharges the power to the output for the remaining period. The external MOSFET remains off until the output voltage needs to be boosted again.

Dimming Control

Two dimming methods, PWM and analog dimming mode, are allowed.

For PWM dimming, apply a PWM signal to PWM. The LED current is chopped by this PWM signal, and the average LED current is equal to $I_{SET} * D_{DIM}$, where D_{DIM} is the duty cycle of the PWM dimming signal, and I_{SET} is the LED current amplitude.

For analog dimming, either a PWM signal or a DC signal can be applied to ADIM.

When a PWM signal is applied to ADIM, this signal is filtered by the internal RC filter. The LED current amplitude is equal to $I_{SET} \cdot D_{DIM}$, where D_{DIM} is the duty cycle of the PWM dimming signal, and I_{SET} is the LED current amplitude. A 20kHz or higher PWM signal is recommended for better filtering performance. When a DC signal is applied to ADIM, the voltage ranging from 0.41V to 1.49V sets the LED current linearly from minimum to full scale directly.

Open-String Protection

Open-string protection is achieved through OVP and LEDX (1 to 4). If one or more strings are open, the respective LEDXs are pulled to ground, and the WLED controller keeps charging the output voltage until it reaches the over-voltage protection (OVP) threshold. If the OVP point has been triggered for $>4\mu s$, the WLED controller stops switching and marks off the strings which have an LEDX voltage lower than 190mV. Once marked off, the remaining LED strings force the output voltage back into tight regulation. The string with the largest voltage drop determines the output regulation. If all strings are open, the WLED controller shuts down until the WLED controller resets.

Short-String Protection

The WLED controller monitors the LEDX voltages to determine if a short-string fault has occurred. If one or more strings are shorted, the respective LEDXs tolerate high-voltage stress. If an LEDX voltage is higher than 6.3V, this condition triggers the detection of a short string. When a short-string fault (LEDX over-voltage fault) remains for 4,096 switching cycles, the fault string is marked off and disabled. Once a string is marked off, it disconnects from the output voltage loop. The marked LED strings shut off completely until the boost part restarts. In order to prevent mistripping the short LED protection when opening the LED string or sharp ADIM, the short LED protection function is disabled when the V_{LEDXS} of all used LED channels are higher than 1.5V.

Inductor/Diode Short Protection

To prevent WLED controller and external MOSFET damage when the external inductor/diode is shorted, the protection mode operates in two methods.

When the inductor/diode is shorted, the output cannot maintain enough energy to load the LED, and the output voltage drops. Thus, the COMP (error amplifier output) voltage rises until it can be clamped high. If it lasts longer than 512 switching cycles, the WLED controller turns off and latches.

However, in some cases, the COMP voltage cannot be clamped to high when the inductor/diode is shorted. The WLED controller provides a protection mode by detecting the current flowing through the power MOSFET. In this mode, when the current senses voltage across the sense resistor (connected between MOSFET and GND) and hits the V_{LMT} limit value (lasting for 4 switching cycles), the WLED controller turns off and latches.

Thermal Shutdown Protection

To prevent the WLED controller from operating at exceedingly high temperatures, a thermal shutdown is implemented in this chip and monitors the silicon die temperature. When the die temperature exceeds the upper threshold (T_{ST}), the WLED controller shuts down. It returns to normal operation when the die temperature drops below the lower threshold. Typically, the hysteresis value is 25°C.

BUCK CONVERTER SECTION:

The buck converter is a step-down, switch-mode converter with built-in internal power MOSFETs and offers a very compact solution. It operates in a fixed-frequency, peak-current-control mode to regulate the output voltage. A PWM cycle is initiated by an internal clock. The integrated high-side power MOSFET is turned on and remains on until its current reaches the value set by the COMP_BUCK voltage (this COMP_BUCK is one of the buck's internal control voltage, not the COMP pin). When the power switch is off, it remains off until the next clock cycle starts. If the current in the power MOSFET does not reach the COMP_BUCK set current value in 95% of one PWM period, the power MOSFET is forced to turn off.

Internal Regulator

Most of the internal circuitries are powered by a 5V internal regulator. This regulator takes the VIN2 input and operates in the full VIN2 range. When VIN2 is greater than 5.0V, the output of the regulator is in full regulation. When VIN2 is lower than 5.0V, the output decreases. A 0.1 μ F ceramic capacitor is required for decoupling purposes.

Error Amplifier

The error amplifier compares the FB voltage with the internal 0.8V reference (REF) and outputs a COMP_BUCK voltage, which is used to control the power MOSFET current. The optimized internal compensation network minimizes the external component count and simplifies the control loop design.

SYNC Control

The buck converter can be synchronized to an external clock ranging from 250kHz to 2MHz through SYNC. The internal clock's rising edge is synchronized to the external clock's falling edge. The synchronized logic high voltage should be higher than 1.8V, and the synchronized logic low voltage should be lower than 0.6V. The frequency of the external clock should be higher than the internal clock. Otherwise the internal clock may turn on the high-side MOSFET.

Under-Voltage Lockout (UVLO)

Under-voltage lockout (UVLO) is implemented to protect the buck converter from operating at insufficient supply voltages by monitoring the output voltage of the internal regulator (VCC2). The UVLO rising threshold is about 3.9V while its falling threshold is consistently 3.25V.

Internal Soft Start (SS)

The soft start is implemented to prevent the converter output voltage from overshooting during start-up. When the chip starts up, the internal circuitry generates a soft-start voltage (SS) and ramps up from 0V. The soft-start period lasts until the voltage of the soft-start capacitor exceeds the reference voltage of 0.8V. At this point, the reference voltage takes over. The soft-start time is set internally to around 1.5ms.

Over-Current Protection and Hiccup Mode

The cycle-by-cycle over-current limit is implemented when the inductor current peak value exceeds the set current limit threshold. The output voltage drops until FB is below the under-voltage (UV) threshold, typically 50% below the reference. Once UV is triggered, the buck converter enters hiccup mode to restart the part periodically. This protection mode is especially useful when the output is dead-shortened to ground. The average short-circuit current is greatly reduced to alleviate thermal issues and protect the regulator. The buck converter exits hiccup mode once the over-current condition is removed.

Thermal Shutdown

Thermal shutdown is implemented to prevent the chip from operating at exceedingly high temperatures. When the silicon die temperature is higher than 150°C, the buck converter shuts down. When the temperature is lower than its lower threshold, typically 130°C, the buck converter is enabled again.

Floating Driver and Bootstrap Charging

The floating power MOSFET driver is powered by an external bootstrap capacitor. This floating driver has its own UVLO protection. The UVLO rising threshold is 2.2V with a hysteresis of 150mV. The bootstrap capacitor voltage is regulated internally by VIN2 through DB, R6, C7, L2, and C5 (see Figure 3). If VIN2-VSW is more than 5V, then U1 will regulate MB to maintain a 5V BST voltage across C7.

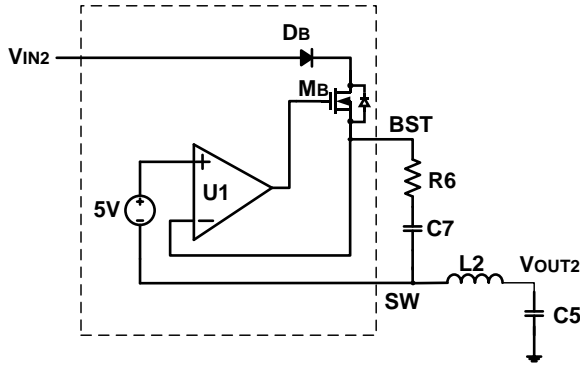

Figure 3: Internal Bootstrap Charging Circuit

Start-Up and Shutdown

If VIN2 is higher than its appropriate thresholds, the buck converter starts up. The reference block starts first, generating stable reference voltages and currents, and then the internal regulator is enabled. The regulator provides a stable supply for the remaining circuitries.

Three events can shut down the buck converter: EN2 low, VIN2 UVLO, and thermal shutdown. During the shutdown procedure, the signaling path is first blocked to avoid any fault triggering. The COMP voltage and the internal supply rail are then pulled down. The floating driver is not subject to this shutdown command.

APPLICATION INFORMATION

WLED CONTROLLER SECTION:

Selecting the Switching Frequency

The switching frequency of the step-up converter is recommended to be between 300kHz to 500kHz for most applications. An oscillator resistor on OSC sets the internal oscillator frequency for the step-up converter, according to Equation (1):

$$F_{SW1}(\text{KHz}) = \frac{67320}{R_{osc}(\text{K}\Omega)} \quad (1)$$

When $R_{OSC}=224\text{k}\Omega$, the switching frequency is set to 300kHz.

Setting the LED Current

Each LED string current can be set through the current setting resistor on ISET using Equation (2):

$$I_{LED}(\text{mA}) = \frac{795 \times 1.23}{R_{SET}(\text{K}\Omega)} \quad (2)$$

When $R_{SET}=8.06\text{k}\Omega$, the LED current is set to 120mA. Do NOT leave ISET open.

Selecting the Input Capacitor

The input capacitor reduces the surge current drawn from the input supply and the switching noise from the device. The input capacitor impedance at the switching frequency should be less than the input source impedance to prevent the high-frequency switching current from passing through to the input. Ceramic capacitors with X5R or X7R dielectrics are recommended because of their low ESR and small temperature coefficients. For most applications, use a $4.7\mu\text{F}$ ceramic capacitor in parallel with a $220\mu\text{F}$ electrolytic capacitor.

Selecting the Inductor and Current Sensing Resistor

A larger value inductor results in less ripple current, lower peak inductor currents, and reduced stress on the N-channel MOSFET. However, the larger value inductor has a larger physical size, a higher series resistance, and a lower saturation current.

Choose an inductor that does not saturate under the worst-case load conditions. Select the

minimum inductor value to ensure that the boost converter works in continuous conduction mode with high efficiency and good EMI performance. Calculate the required inductance values using Equation (3) and Equation (4):

$$L1 \geq \frac{\eta \times V_{OUT1} \times D \times (1-D)^2}{2 \times f_{SW1} \times I_{LOAD1}} \quad (3)$$

$$D = 1 - \frac{V_{IN1}}{V_{OUT1}} \quad (4)$$

Where V_{IN1} and V_{OUT1} are the input and output voltages, f_{SW1} is the switching frequency, I_{LOAD1} is the total LED load current, and η is the efficiency.

Usually, the switching current is used for peak-current-mode control. To avoid hitting the current limit, the voltage across the sensing resistor (R_{SENSE}) must be less than 80% of the worst-case current-limit voltage (V_{SENSE}). See Equation (5) and Equation (6):

$$R_{SENSE} = \frac{0.8 \times V_{SENSE}}{I_{L1(PEAK)}} \quad (5)$$

$$I_{L1(PEAK)} = \frac{V_{OUT1} \times I_{LOAD1}}{\eta V_{IN1}} + \frac{V_{IN1} \times (V_{OUT1} - V_{IN1})}{2 \times L1 \times F_{SW1} \times V_{OUT1}} \quad (6)$$

Where $I_{L1(PEAK)}$ is the peak value of the inductor current. V_{SENSE} is shown in Figure 4.

Vsense vs. Duty Cycle

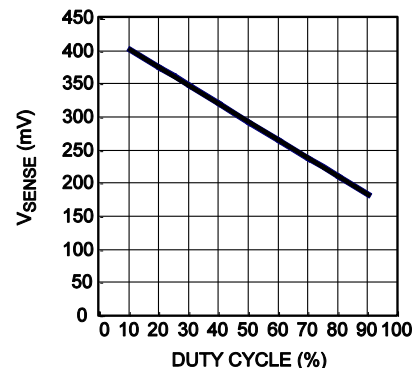

Figure 4: V_{SENSE} vs. Duty Cycle

Selecting the Power MOSFET

The critical parameters for selecting a MOSFET are listed below:

1. Maximum drain-to-source voltage, $V_{DS(MAX)}$.
2. Maximum current, $I_{D(MAX)}$.
3. On-resistance, $R_{DS(ON)}$.
4. Gate source charge (Q_{GS}) and gate drain charge (Q_{GD}).
5. Total gate charge (Q_G).

Ideally, the off-state voltage across the MOSFET is equal to the output voltage. Considering the voltage spike when it turns off, $V_{DS(MAX)}$ should be greater than 1.5 times the output voltage.

The maximum current through the power MOSFET occurs at the minimum input voltage and the maximum output power. The maximum RMS current through the MOSFET is given by Equation (7) and Equation (8):

$$I_{RMS(MAX)} = I_{IN1(MAX)} \times \sqrt{D_{MAX}}, \text{ where:} \quad (7)$$

$$D_{MAX} \approx \frac{V_{OUT1} - V_{IN1(MIN)}}{V_{OUT1}} \quad (8)$$

The current rating of the MOSFET should be greater than $1.5 \times I_{RMS}$.

The on resistance of the MOSFET determines the conduction loss, which is given by Equation (9):

$$P_{cond} = I_{RMS}^2 \times R_{DS(on)} \times k \quad (9)$$

Where k is the temperature coefficient of the MOSFET.

The switching loss is related to Q_{GD} and Q_{GS1} , which determine the commutation time. Q_{GS1} is the charge between the threshold voltage and the plateau voltage when a driver charges the gate, which can be read in the V_{GS} vs Q_G chart of the MOSFET datasheet. Q_{GD} is the charge during the plateau voltage. These two parameters are needed to estimate the turn-on and turn-off losses and can be calculated with Equation (10):

$$P_{sw} = \frac{Q_{GS1} \times R_G}{V_{DR} - V_{TH}} \times V_{DS} \times I_{IN1} \times f_{SW1} + \frac{Q_{GD} \times R_G}{V_{DR} - V_{PLT}} \times V_{DS} \times I_{IN1} \times f_{SW1} \quad (10)$$

Where V_{TH} is the threshold voltage, V_{PLT} is the plateau voltage, R_G is the gate resistance, and V_{DS} is the drain source voltage. Please note that calculating the switching loss is the most difficult part in the loss estimation. The formula above is a simplified equation. For a more accurate estimation, the equation becomes much more complex.

The total gate charge (Q_G) is used to calculate the gate drive loss. See Equation (11):

$$P_{DR} = Q_G \times V_{DR} \times f_{SW1} \quad (11)$$

Where V_{DR} is the drive voltage.

Selecting the Output Capacitor

The output capacitor keeps the output voltage ripple small and ensures feedback loop stability. The output capacitor impedance must be low at the switching frequency. Ceramic capacitors with X7R dielectrics are recommended for their low ESR characteristics. For most applications, a 4.7 μ F ceramic capacitor in parallel with a 22 μ F electrolytic capacitor is sufficient.

Setting the Over-Voltage Protection

The open-string protection is achieved through the detection of the voltage on OVP. In some cases, an LED string failure results in a feedback voltage of zero. The part then boosts the output voltage higher and higher. If the output voltage reaches the programmed OVP threshold, the protection will be triggered.

To ensure the chip functions properly, select the resistor values for the OVP resistor divider to provide an appropriate set voltage. The recommended OVP point is about 1.1 to 1.2 times higher than the output voltage for normal operation. See Equation (12):

$$V_{OVP} = 1.23 \times \left(1 + \frac{R_{HIGH}}{R_{LOW}}\right) \quad (12)$$

Selecting the Dimming Control Mode

Two different dimming methods are provided:

1. Direct PWM Dimming

An external PWM dimming signal is employed to achieve PWM dimming control. Apply a PWM dimming signal (ranging from 100Hz to 20kHz) to PWM. The minimum recommended amplitude of the PWM signal is 1.5V, and the low level should be less than 0.4V (see Table 1).

Table 1: The Range of PWM Dimming Duty

f_{PWM} (Hz)	D_{min}	D_{max}
$100 < f \leq 200$	0.30%	100%
$200 < f \leq 500$	0.75%	100%
$500 < f \leq 1k$	1.50%	100%
$1k < f \leq 2k$	3.00%	100%
$2k < f \leq 5k$	7.50%	100%
$5k < f \leq 10k$	15.00%	100%
$10k < f \leq 20k$	30.00%	100%

2. Analog Dimming

For analog dimming, apply a PWM signal or a DC voltage signal to ADIM. An internal RC filter (10M Ω resistor and 100pF capacitor) is integrated to ADIM. If a PWM signal is applied to ADIM, a >20kHz frequency is recommended for better PWM signal filtering performance and to ensure the amplitude voltage is higher than 1.5V, and the low-level voltage is less than 0.4V. For the DC signal input, apply a DC input signal ranging from 0.41V to 1.49V to set the LED current from minimum to full scale linearly.

BUCK CONVERTER SECTION:

Setting the Output Voltage

The external resistor divider is used to set the output voltage. The feedback resistor R1 also sets the feedback loop bandwidth with the internal compensation capacitor. When R1 is fixed, R2 is then given by Equation (13):

$$R2 = \frac{R1}{\frac{V_{OUT2}}{0.8V} - 1} \quad (13)$$

The T-type network is highly recommended (see Figure 5).

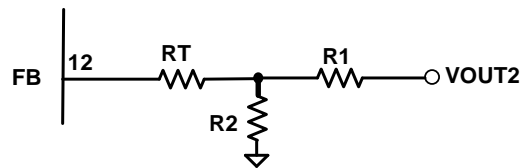

Figure 5: T-type Network

Table 2 below lists the recommended T-type resistor values for the common 5V output voltage.

Table 2: Resistor Selection for Common Output Voltages

V_{OUT2} (V)	R1 (k Ω)	R2 (k Ω)	RT (k Ω)	L2 (μ H)	Co (μ F)
5	40.2	7.5	51	10	66

Selecting the Inductor

A 4.7 μ H to 10 μ H inductor with a DC current rating at least 25% higher than the maximum load current is recommended for most applications. For the highest efficiency, the inductor DC resistance should be less than 15m Ω . For most designs, the inductance value can be derived from Equation (14):

$$L2 = \frac{V_{OUT2} \times (V_{IN2} - V_{OUT2})}{V_{IN2} \times \Delta I_{L2} \times F_{OSC}} \quad (14)$$

Where ΔI_{L2} is the inductor ripple current.

Set the inductor current to be approximately 30% of the maximum load current. The maximum inductor peak current is calculated with Equation (15):

$$I_{L2(MAX)} = I_{LOAD2} + \frac{\Delta I_{L2}}{2} \quad (15)$$

Under light-load conditions below 100mA, a larger inductance is recommended for improved efficiency.

Selecting the Input Capacitor

The input current to the step-down converter is discontinuous, and therefore a capacitor is required to supply the AC current to the step-down converter while maintaining the DC input voltage. Use low ESR capacitors for the best performance. Ceramic capacitors with X5R or X7R dielectrics are highly recommended because of their low ESR and small temperature coefficients. For most applications, a 22μF capacitor is sufficient.

Since the input capacitor (C4) absorbs the input switching current, it requires an adequate ripple current rating. The RMS current in the input capacitor can be estimated by Equation (16):

$$I_{C4} = I_{LOAD2} \times \sqrt{\frac{V_{OUT2}}{V_{IN2}} \times \left(1 - \frac{V_{OUT2}}{V_{IN2}}\right)} \quad (16)$$

The worse-case condition occurs at $V_{IN2} = 2V_{OUT2}$, shown in Equation (17):

$$I_{C4} = \frac{I_{LOAD2}}{2} \quad (17)$$

For simplification, choose an input capacitor with an RMS current rating greater than half of the maximum load current.

The input capacitor can be electrolytic, tantalum, or ceramic. When electrolytic or tantalum capacitors are used, a small, high-quality ceramic capacitor (i.e. 0.1μF) should be placed as close to the IC as possible. When using ceramic capacitors, make sure that they have enough capacitance to provide a sufficient enough charge to prevent excessive voltage ripple at the input. The input voltage ripple caused by capacitance can be estimated with Equation (18):

$$\Delta V_{IN2} = \frac{I_{LOAD2}}{F_{SW2} \times C4} \times \frac{V_{OUT2}}{V_{IN2}} \times \left(1 - \frac{V_{OUT2}}{V_{IN2}}\right) \quad (18)$$

Selecting the Output Capacitor

The output capacitor C5 is required to maintain the DC output voltage. Ceramic, tantalum, or low ESR electrolytic capacitors are recommended. Low ESR capacitors are preferred to keep the

output voltage ripple low. The output voltage ripple can be estimated with Equation (19):

$$\Delta V_{OUT2} = \frac{V_{OUT2}}{F_{SW2} \times L2} \times \left(1 - \frac{V_{OUT2}}{V_{IN2}}\right) \times \left(R_{ESR} + \frac{1}{8 \times F_{SW2} \times C5}\right) \quad (19)$$

Where L2 is the inductor value and R_{ESR} is the equivalent series resistance (ESR) value of the output capacitor.

When using ceramic capacitors, the impedance at the switching frequency is dominated by the capacitance, which mainly causes the output voltage ripple. For simplification, the output voltage ripple can be estimated with Equation (20):

$$\Delta V_{OUT2} = \frac{V_{OUT2}}{8 \times F_{SW2}^2 \times L2 \times C5} \times \left(1 - \frac{V_{OUT2}}{V_{IN2}}\right) \quad (20)$$

When using tantalum or electrolytic capacitors, the ESR dominates the impedance at the switching frequency. For simplification, the output ripple can be approximated with Equation (21):

$$\Delta V_{OUT2} = \frac{V_{OUT2}}{F_{SW2} \times L2} \times \left(1 - \frac{V_{OUT2}}{V_{IN2}}\right) \times R_{ESR} \quad (21)$$

The characteristics of the output capacitor affect the stability of the regulation system.

External Bootstrap Diode

An external bootstrap diode may enhance the efficiency of the regulator. The applicable conditions of the external BST diode are:

- V_{OUT2} is 5V or 3.3V;
- duty cycle is high: $D = \frac{V_{OUT2}}{V_{IN2}} > 65\%$

In these cases, an external BST diode from VCC2 to BST is recommended (see Figure 6). The recommended external BST diode is 1N4148, and the BST cap is 0.1–1μF.

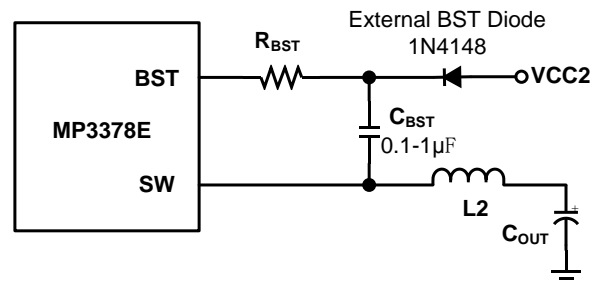

Figure 6: Add Optional External Bootstrap Diode to Enhance Efficiency

PCB Layout Guidelines

Efficient PCB layout is critical for achieving stable operation. If the layout is not done carefully, the regulator can show poor line or load regulation. For best results, refer to Figure 7 and Figure 8 and follow the guidelines below:

For the WLED converter (see Figure 7):

1. Keep the loop from the external MOSFET (M1), the output diode (D1), and the output capacitors (C2, C3) as small and short as possible to reduce EMI noise.
2. Separate the power ground and signal ground.
3. Connect PGND and GND.

NOTE: All logic signals refer to the signal ground.

For the buck converter (see Figure 8):

1. Keep the connection of input ground and GND2 (PGND) as short and wide as possible.
2. Keep the connection of the input capacitors (C16, C16A, C17) and VIN2 as short and wide as possible.
3. Ensure that all feedback connections are short and direct.
4. Place the feedback resistors and compensation components as close to the chip as possible.
5. Route SW away from sensitive analog areas, such as FB.
6. Connect a resistor (R23) to AGND, as SYNC is sensitive to noise. Otherwise, the SCP may fail, and the buck converter may be damaged.
7. Connect GND1 and GND2 together by a single point.

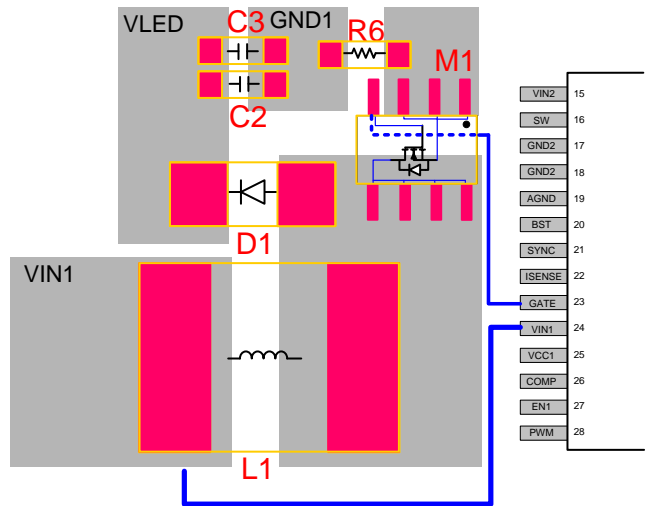

Figure 7: Recommended Boost Driver Layout

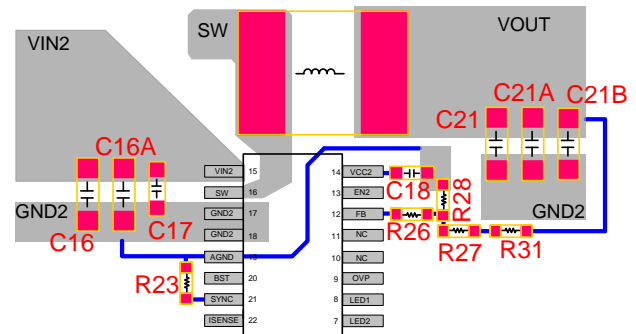

Figure 8: Recommended Buck Converter Layout

TYPICAL APPLICATION CIRCUITS

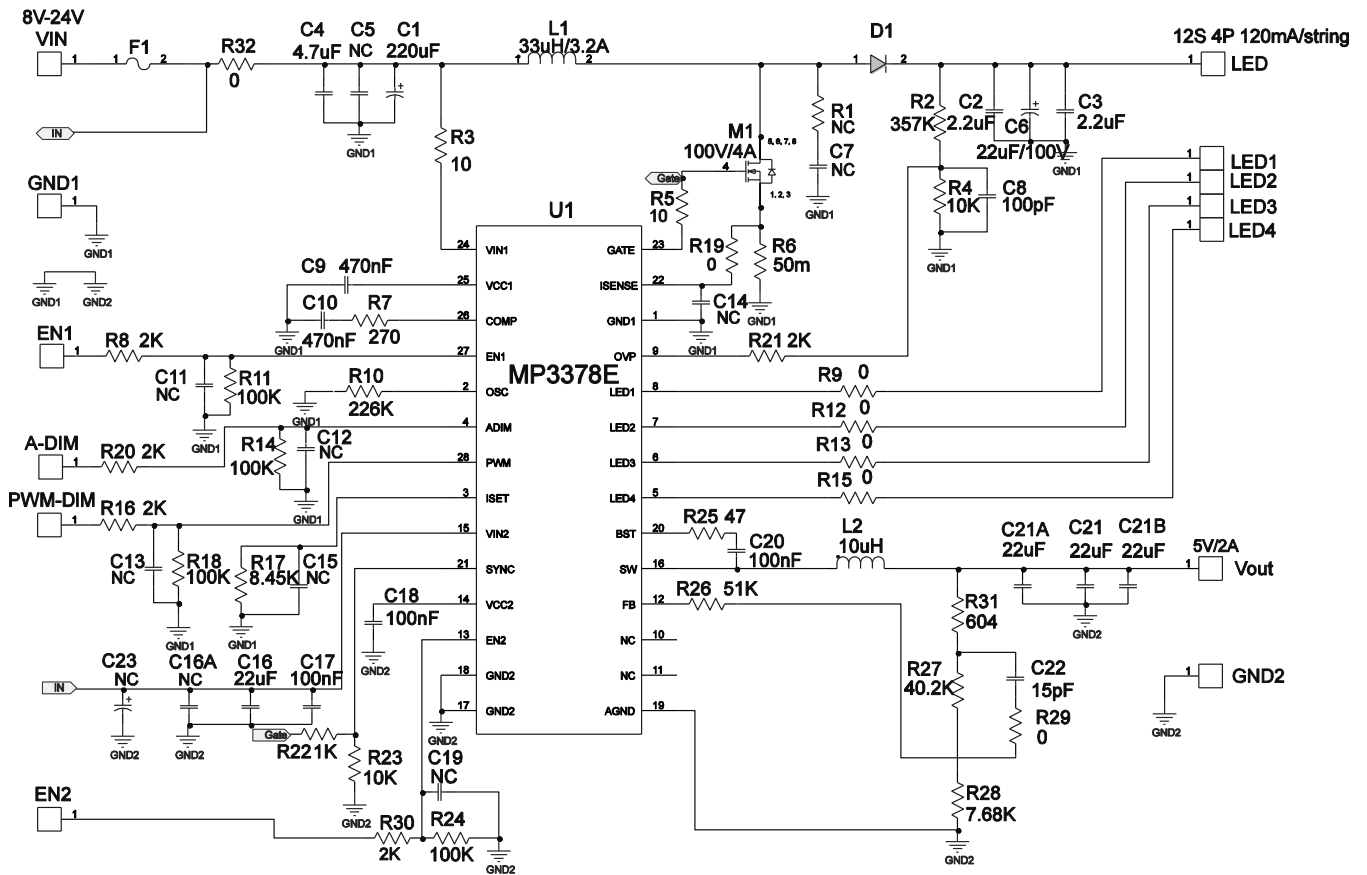
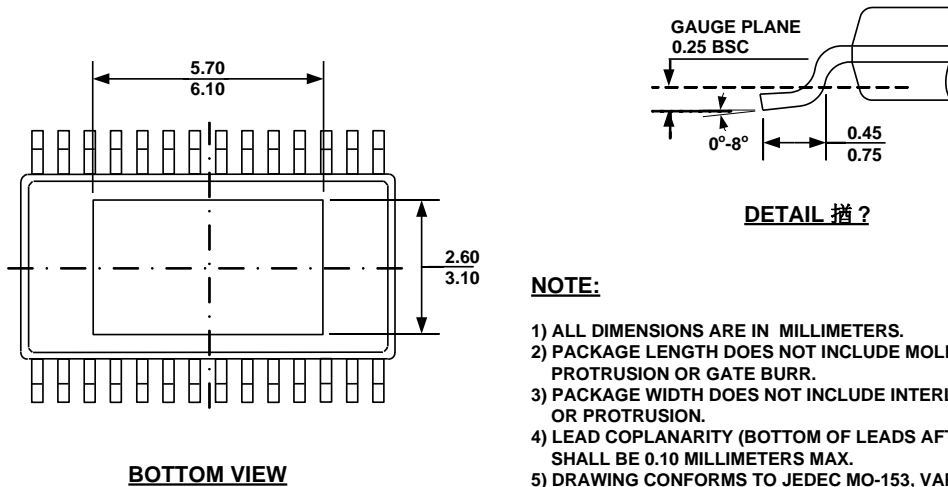
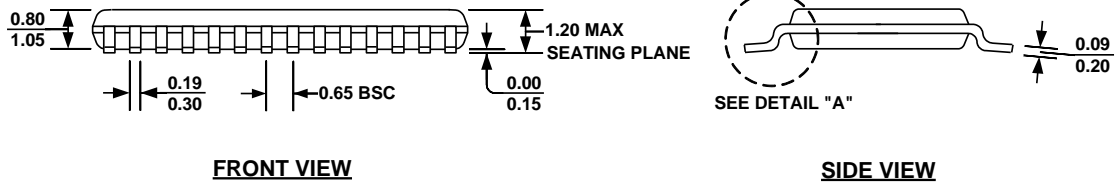
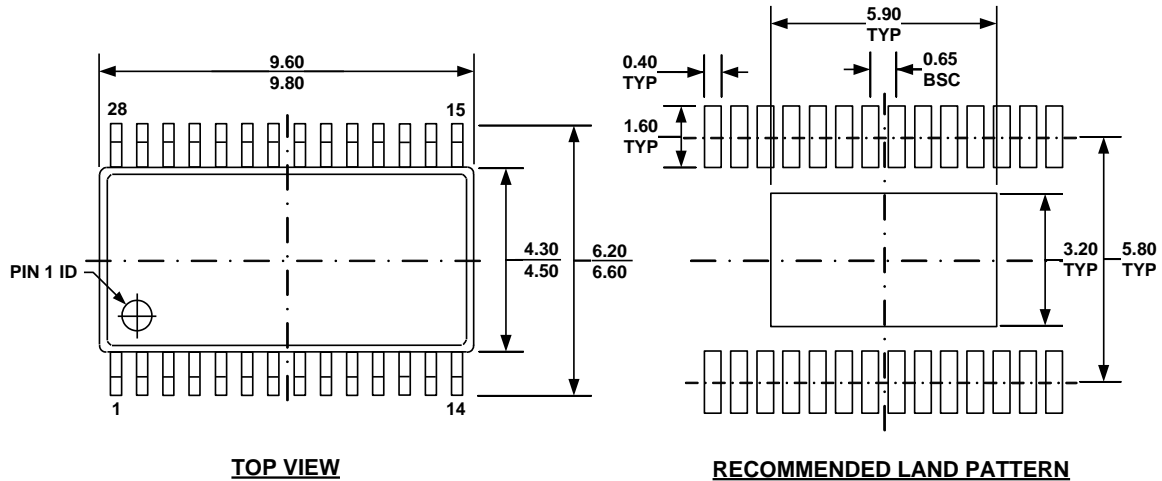

Figure 9: 4-String, 12-LED In-Series, 120mA/String Plus 5V Output Application

PACKAGE INFORMATION

TSSOP-28 EP



NOTE:

- 1) ALL DIMENSIONS ARE IN MILLIMETERS.
- 2) PACKAGE LENGTH DOES NOT INCLUDE MOLD FLASH, PROTRUSION OR GATE BURR.
- 3) PACKAGE WIDTH DOES NOT INCLUDE INTERLEAD FLASH OR PROTRUSION.
- 4) LEAD COPLANARITY (BOTTOM OF LEADS AFTER FORMING) SHALL BE 0.10 MILLIMETERS MAX.
- 5) DRAWING CONFORMS TO JEDEC MO-153, VARIATION AET.
- 6) DRAWING IS NOT TO SCALE.

NOTICE: The information in this document is subject to change without notice. Users should warrant and guarantee that third party Intellectual Property rights are not infringed upon when integrating MPS products into any application. MPS will not assume any legal responsibility for any said applications.