

BEE click™

1. Introduction

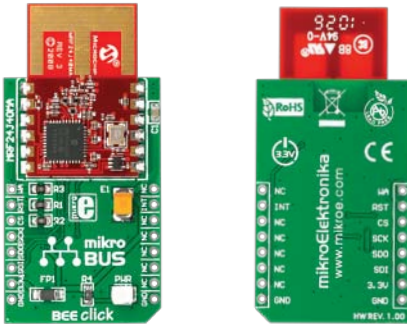

BEE click is an accessory board in **mikroBus™** form factor. It features 2.4 GHz IEEE 802.15.4 radio transceiver module **MRF24J40MA**. This module includes an integrated PCB antenna and matching circuitry and is connected to the microcontroller via a SPI interface. As such, this module is an ideal solution for wireless networks, smart home and building automation, and other electronic applications that need wireless communication. Board is designed to use 3.3V power supply only.

2. Soldering the headers

Before using your click board, make sure to solder the provided 1x8 male headers to both sides of the board. Two 1x8 male headers are included with the board in the package.



1

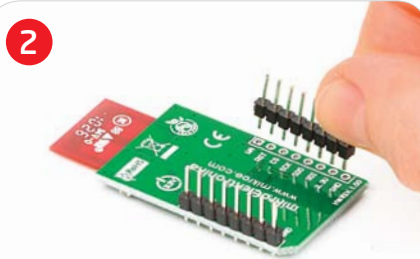

2

Turn the board upside down, so that bottom side is facing you upwards. Place shorter parts of the header pins in the both soldering pad locations.



3

Turn the board upward again. Make sure to align the headers so that they are perpendicular to the board, then solder the pins carefully.

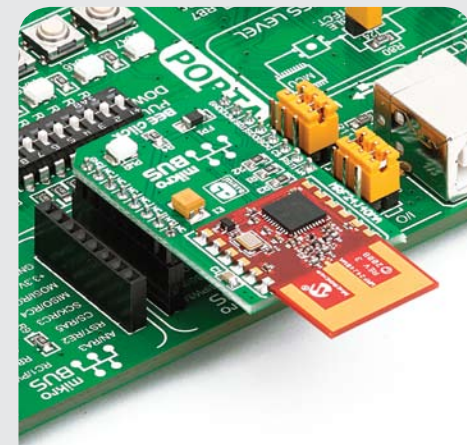

4. Board applications

MRF24J40MA is IEEE 802.15.4™ standard compliant RF transceiver and a great choice for building automation & monitoring, industrial monitoring, automated meter reading, security, inventory management and more. It supports ZigBee®, MiWi™, MiWi P2P and proprietary wireless networking protocols with data rates of 250 kbps (IEEE 802.15.4).

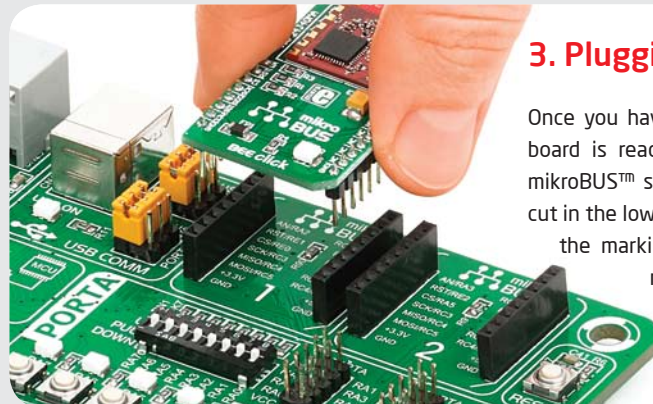

3. Plugging the board in

Once you have soldered the headers your board is ready to be placed into desired mikroBUS™ socket. Make sure to align the cut in the lower-right part of the board with the markings on the silkscreen at the mikroBUS™ socket. If all the pins are aligned correctly, push the board all the way into the socket.

click™
BOARD
www.mikroe.com

Bee click Manual
ver. 1.00



0 100000 018101

5. BEE click Board Schematics

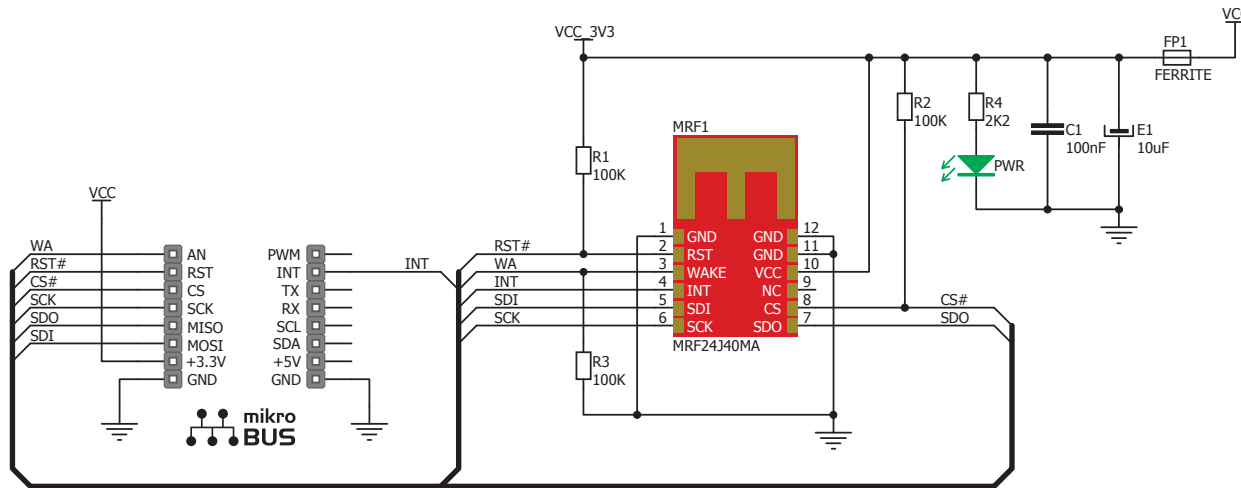

6. Power supply - 3.3V only



Board is designed to use 3.3V power supply only. If you need to add ZigBee™ feature to your 5V prototype or development board, we recommend you to use other boards such as the EasyBee 3 board:

<http://www.mikroe.com/eng/products/view/364/easybee3-board/>

7. Code Examples

Once you have done all the necessary preparations, it's time to get your click board up and running. We have provided the examples for mikroC, mikroBasic and mikroPascal compilers on our **Libstock** website. Just download them and you are ready to start.



8. Support

MikroElektronika offers **Free Tech Support** (www.mikroe.com/esupport) until the end of product lifetime, so if something goes wrong, we are ready and willing to help!

