

MECHANICAL DATA

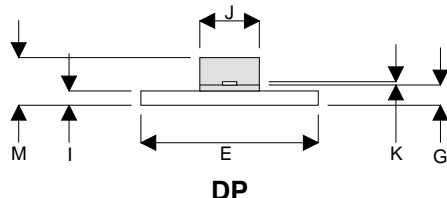
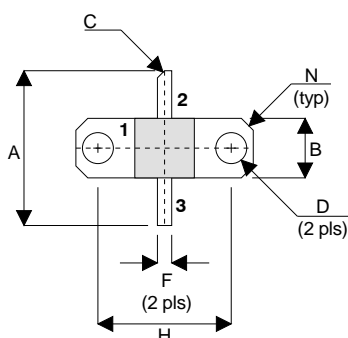

PIN 1 SOURCE PIN 2 DRAIN
PIN 3 GATE

DIM	mm	Tol.	Inches	Tol.
A	16.51	0.25	0.650	0.010
B	6.35	0.13	0.250	0.005
C	45°	5°	45°	5°
D	3.30	0.13	0.130	0.005
E	18.92	0.08	0.745	0.003
F	1.52	0.13	0.060	0.005
G	2.16	0.13	0.085	0.005
H	14.22	0.08	0.560	0.003
I	1.52	0.13	0.060	0.005
J	6.35	0.13	0.250	0.005
K	0.13	0.03	0.005	0.001
M	5.08	0.51	0.200	0.020
N	1.27 x 45°	0.13	0.050 x 45°	0.005

GOLD METALLISED MULTI-PURPOSE SILICON DMOS RF FET 20W – 28V – 500MHz SINGLE ENDED

FEATURES

- SIMPLIFIED AMPLIFIER DESIGN
- SUITABLE FOR BROAD BAND APPLICATIONS
- LOW C_{rss}
- USEFUL P_O AT 1GHz
- LOW NOISE
- HIGH GAIN – 13 dB MINIMUM

APPLICATIONS

- HF/VHF/UHF COMMUNICATIONS
from 1 MHz to 1 GHz

ABSOLUTE MAXIMUM RATINGS ($T_{case} = 25^\circ C$ unless otherwise stated)

P_D	Power Dissipation	50W
BV_{DSS}	Drain – Source Breakdown Voltage	70V
BV_{GSS}	Gate – Source Breakdown Voltage	$\pm 20V$
$I_{D(sat)}$	Drain Current	5A
T_{stg}	Storage Temperature	-65 to 150°C
T_j	Maximum Operating Junction Temperature	200°C

Semelab Ltd reserves the right to change test conditions, parameter limits and package dimensions without notice. Information furnished by Semelab is believed to be both accurate and reliable at the time of going to press. However Semelab assumes no responsibility for any errors or omissions discovered in its use. Semelab encourages customers to verify that datasheets are current before placing orders.

ELECTRICAL CHARACTERISTICS (T_{case} = 25°C unless otherwise stated)

Parameter	Test Conditions	Min.	Typ.	Max.	Unit
BV _{DSS} Drain-Source Breakdown Voltage	V _{GS} = 0 I _D = 100mA	70			V
I _{DSS} Zero Gate Voltage Drain Current	V _{DS} = 28V V _{GS} = 0			1	mA
I _{GSS} Gate Leakage Current	V _{GS} = 20V V _{DS} = 0			1	μA
V _{GS(th)} Gate Threshold Voltage*	I _D = 10mA V _{DS} = V _{GS}	1		7	V
g _{fs} Forward Transconductance*	V _{DS} = 10V I _D = 1A	0.8			S
G _{PS} Common Source Power Gain	P _O = 20W	13			dB
η Drain Efficiency	V _{DS} = 28V I _{DQ} = 0.2A	50			%
VSWR Load Mismatch Tolerance	f = 500MHz	20:1			—
C _{iss} Input Capacitance	V _{DS} = 28V V _{GS} = -5V f = 1MHz			60	pF
C _{oss} Output Capacitance	V _{DS} = 28V V _{GS} = 0 f = 1MHz			30	pF
C _{rss} Reverse Transfer Capacitance	V _{DS} = 28V V _{GS} = 0 f = 1MHz			2.5	pF

* Pulse Test: Pulse Duration = 300 μs , Duty Cycle ≤ 2%

HAZARDOUS MATERIAL WARNING

The ceramic portion of the device between leads and metal flange is beryllium oxide. Beryllium oxide dust is highly toxic and care must be taken during handling and mounting to avoid damage to this area.

THESE DEVICES MUST NEVER BE THROWN AWAY WITH GENERAL INDUSTRIAL OR DOMESTIC WASTE.

THERMAL DATA

R _{THj-case}	Thermal Resistance Junction – Case	Max. 3.5°C / W
-----------------------	------------------------------------	----------------

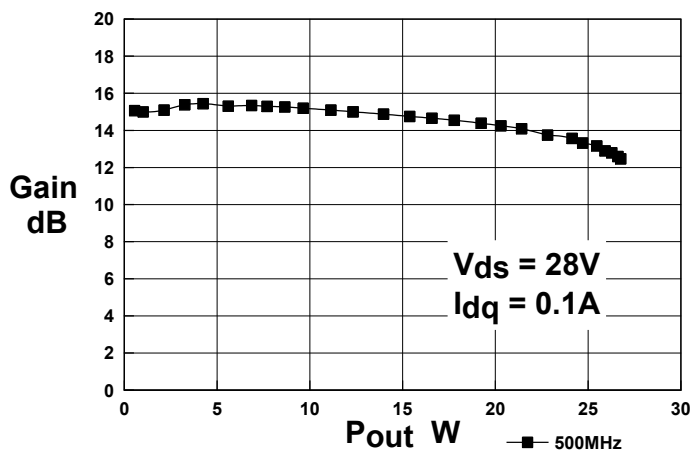

Figure 1
Gain vs. Output Power

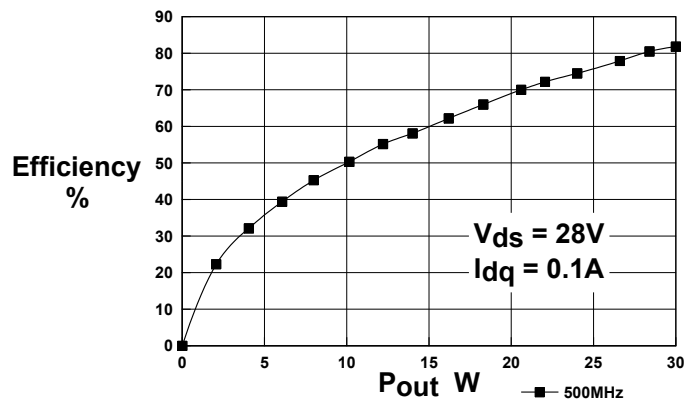

Figure 2
Efficiency vs. Output Power

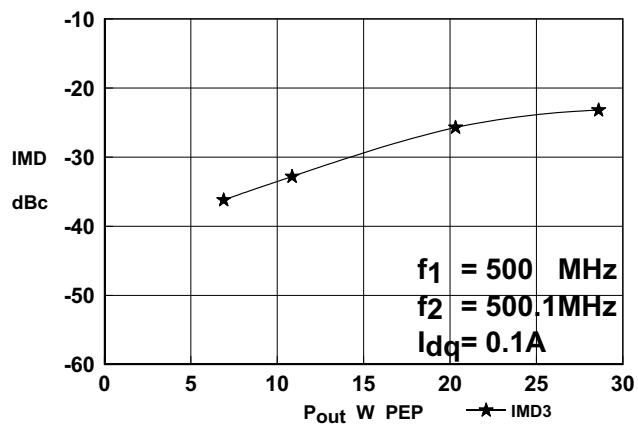
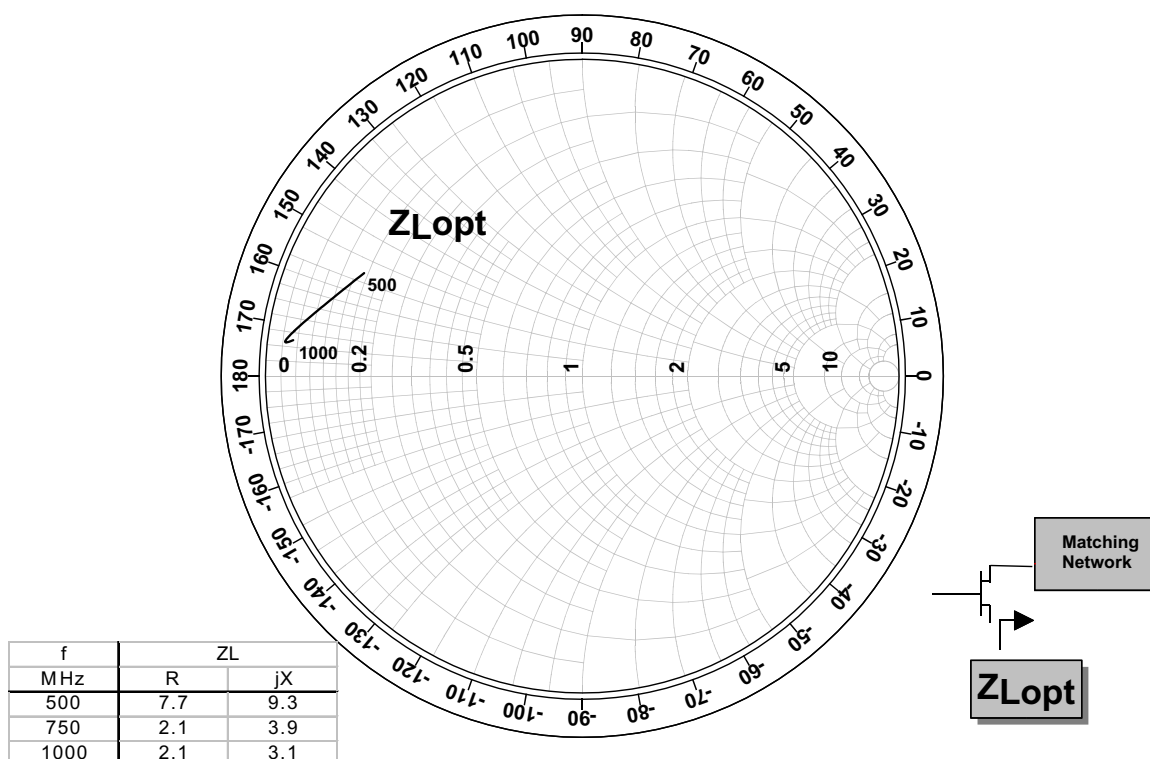
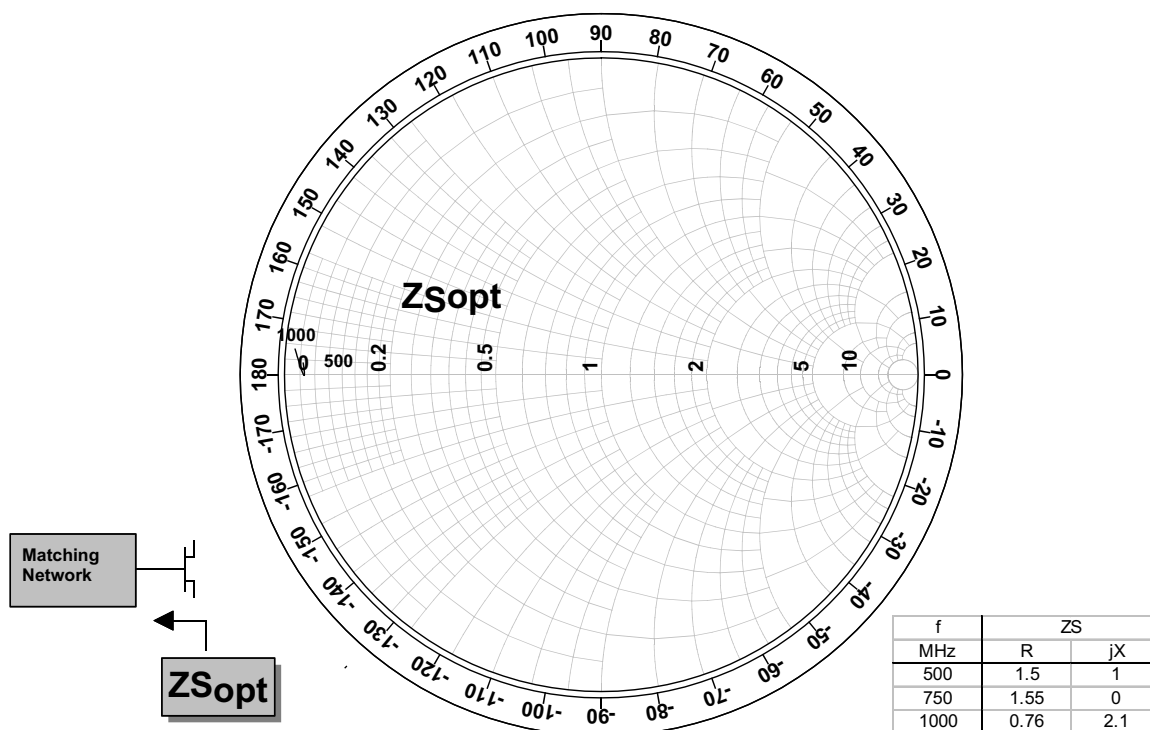
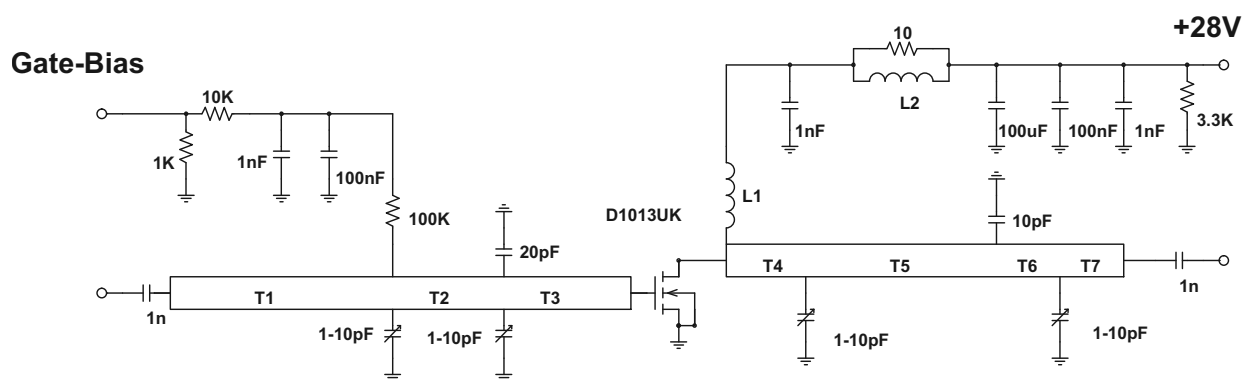

Figure 3
IMD vs. Output Power



Semelab Ltd reserves the right to change test conditions, parameter limits and package dimensions without notice. Information furnished by Semelab is believed to be both accurate and reliable at the time of going to press. However Semelab assumes no responsibility for any errors or omissions discovered in its use. Semelab encourages customers to verify that datasheets are current before placing orders.



500MHz Test Fixture

Substrate 0.8 mm FR4, $\epsilon_r = 2.2$

All microstrip lines $W = 2.2\text{mm}$

T1	35mm
T2	15mm
T3	10mm
T4	14mm
T5	30mm
T6	6mm
T7	12.5mm

L1 5.5 turns 20swg enamelled copper wire 7mm i.d.

L2 1.5 turns 24swg enamelled copper wire on Siemens B62152A7X 2 hole

Semelab Ltd reserves the right to change test conditions, parameter limits and package dimensions without notice. Information furnished by Semelab is believed to be both accurate and reliable at the time of going to press. However Semelab assumes no responsibility for any errors or omissions discovered in its use. Semelab encourages customers to verify that datasheets are current before placing orders.