

THIS DRAWING IS UNPUBLISHED. RELEASED FOR PUBLICATION 20  
© COPYRIGHT 20 BY - ALL RIGHTS RESERVED.

LOC AL DIST 2

REVISIONS

P	LTR	DESCRIPTION	DATE	DWN	APVD
D2		UPDATED VIEW SCALE	23FEB2010	AV	GT
D4		REVISED MARKS ON -5 WAS MARKED AC	17OCT2011	AV	GT
D4		REVISED PER ECR-13-009678	18SEP2013	RS	DD
D5		ECR-16-004670	04APR2016	RS	JL

TYPICAL APPLICATION

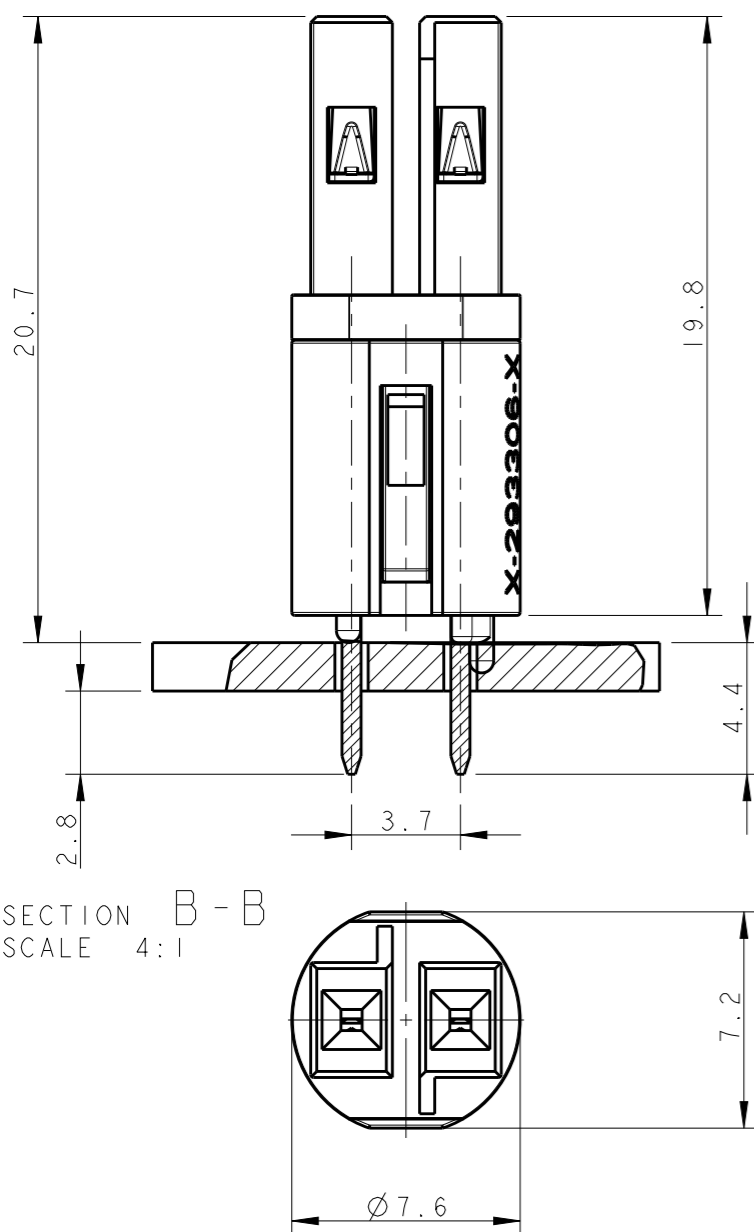
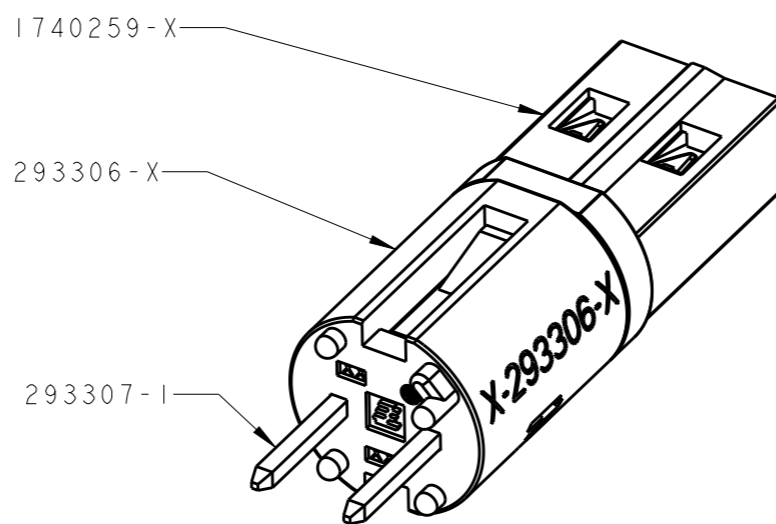

SECTION B-B SCALE 4:1

HIGH VOLTAGE

KEYING HV-1 KEYING HV-2 KEYING HV-3

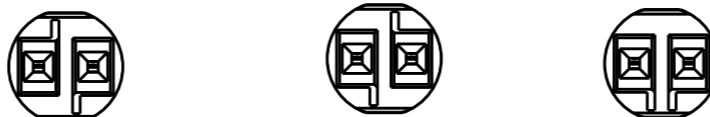

LOW VOLTAGE

KEYING LV-1 KEYING LV-2

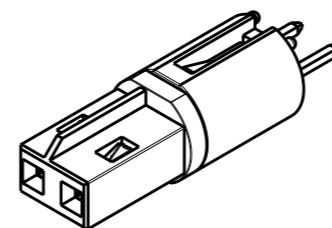

PRINTED CIRCUIT BOARD LAYOUT FOR LOW VOLTAGE VERSION

TOLERANCES UNLESS OTHERWISE SPECIFIED ± 0.05  
PRINTED CIRCUIT BOARD THICKNESS: 1.6 mm NOMINAL

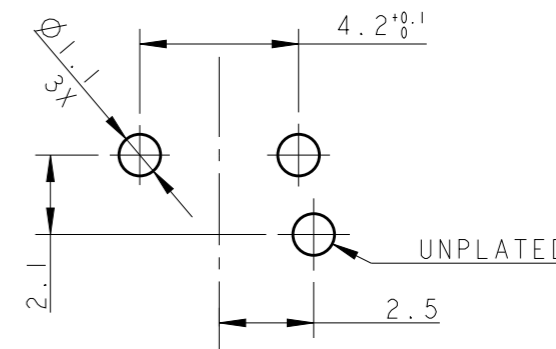

1) MATERIALS:

CONTACTS: SOLDERING SIDE TIN PLATED Ph. BRONZE  
RECEPTACLE IN SPECIAL ALLOY COPPER TIN PLATED  
HOUSING: PA66 GFF25 UL 94 V0

2 OBSOLETE.

KEYING	REMARKS	PART NUMBER	REV	COLOR
LV-2	LOW-VOLT 42 V DC	293308-6	D	YELLOW
LV-1	LOW-VOLT 42 V DC	293308-5	D	LIGHT GREY
HV-2	SWITCH MAX 7A	293308-4	D	RED
HV-3	HIGH-VOLT 125 V AC	293308-3	D	BLUE
HV-1	HIGH-VOLT 250 V AC	293308-2	D	BLACK
HV-1	HIGH-VOLT 250 V AC	293308-1	D	WHITE

PRINTED CIRCUIT BOARD LAYOUT FOR HIGH VOLTAGE VERSION

TOLERANCES UNLESS OTHERWISE SPECIFIED ± 0.05  
PRINTED CIRCUIT BOARD THICKNESS: 1.6 mm NOMINAL

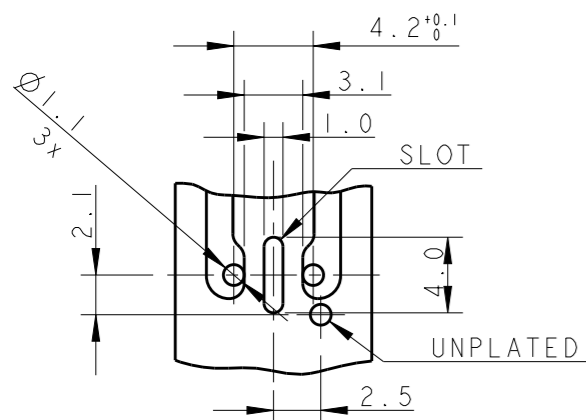

THIS DRAWING IS A CONTROLLED DOCUMENT.

DWN R. FRABONI 15JUN2007

CHK -

APVD G. TURCO

PRODUCT SPEC 108-94018

APPLICATION SPEC 114-32102

WEIGHT -

DIMENSIONS:	TOLERANCES UNLESS OTHERWISE SPECIFIED:
mm	
0 PLC	±0.5
1 PLC	±0.3
2 PLC	±0.3
3 PLC	±0.3
4 PLC	±0.3
ANGLES	±0.5°
MATERIAL	FINISH



NAME 7,5 mm PCB CONNECTOR ASSEMBLY STRAIGHT FEMALE VERSION

SIZE	CAGE CODE	DRAWING NO	RESTRICTED TO
A300779	C-293308		

CUSTOMER DRAWING SCALE 5:1 SHEET 1 OF 1 REV D5