

THIS DRAWING IS UNPUBLISHED. RELEASED FOR PUBLICATION  
 © COPYRIGHT - By - ALL RIGHTS RESERVED.

LOC	DIST	REVISIONS			
P	LTR	DESCRIPTION	DATE	DWN	APVD
FT	47	AG1	REVISED PER ECO-15-003583	07MAR2015	NK MZ

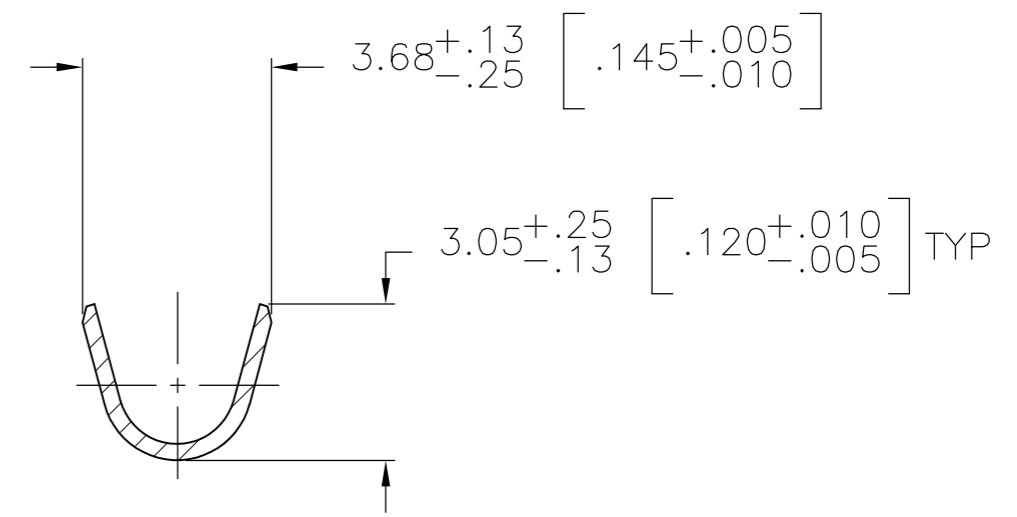

SECTION A-A

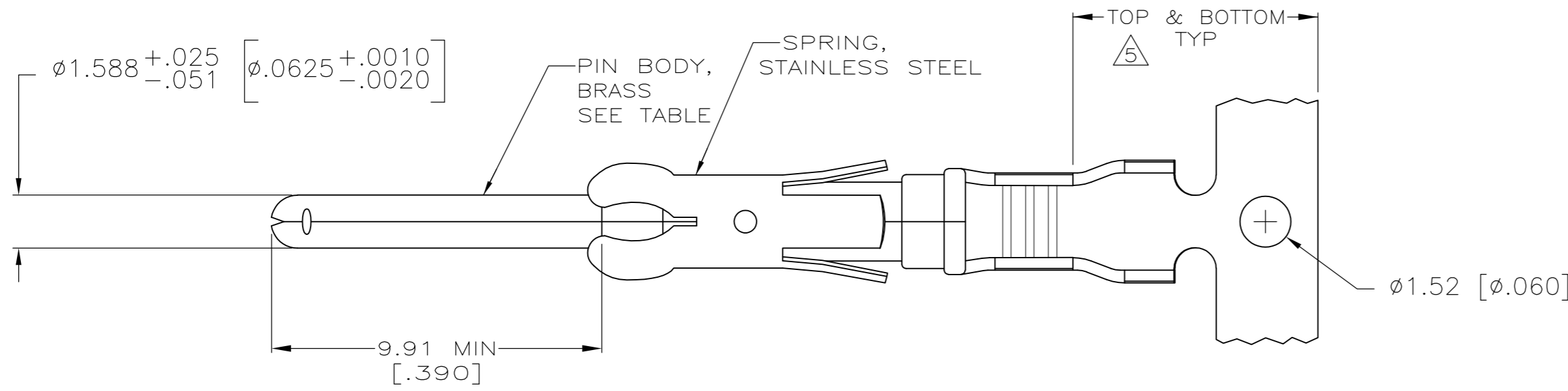
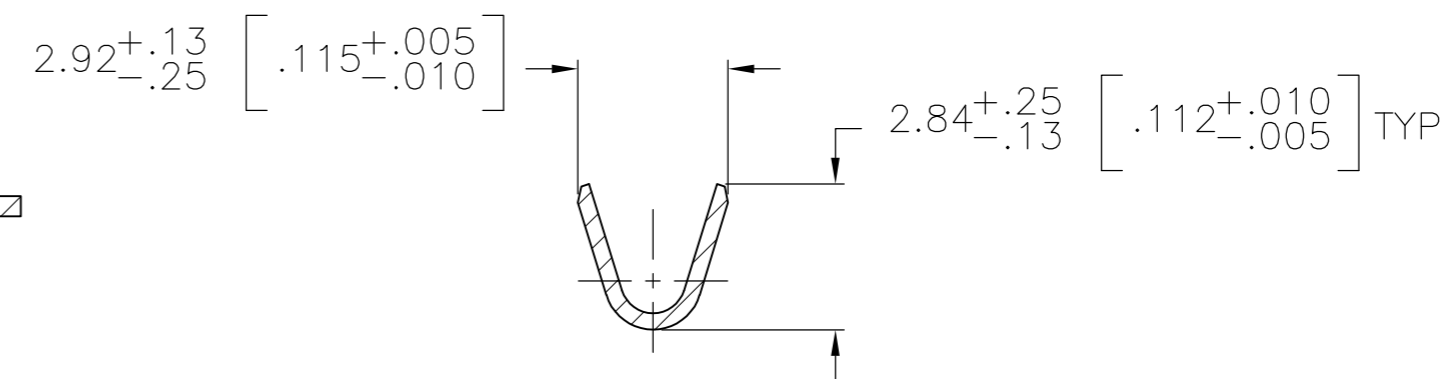
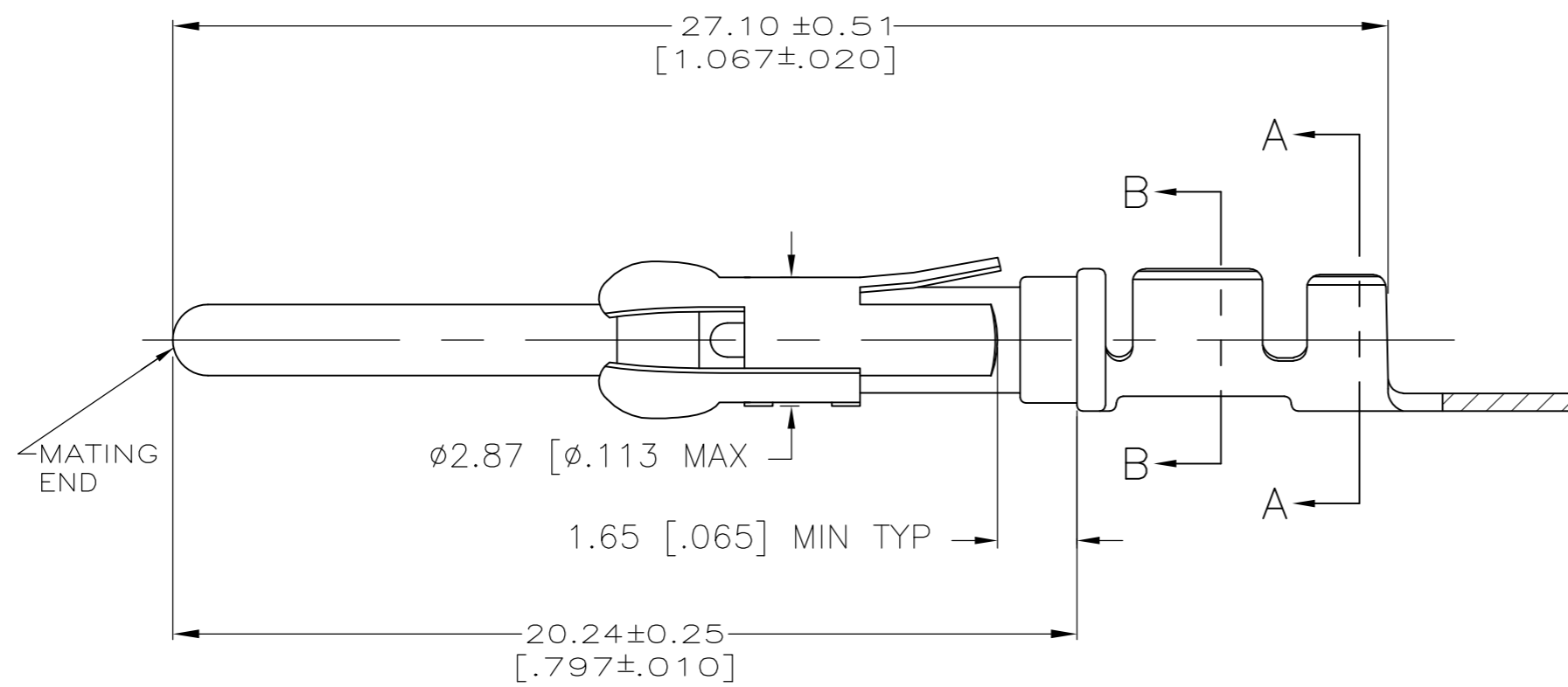

SECTION B-B

- 1 REVERSE REELED FOR MINI-APPLICATOR.
- 2 0.76µm [.000030] MIN PRECIOUS METAL PLATE ON MATING END FOR A LENGTH OF 5.08 [.200] MIN WITH 1.27µm [.000050] MIN MATTE TIN PLATE IN WIRE CRIMP AREA, BOTH OVER 1.27µm [.000050] MIN NICKEL PLATE. CONFORMS TO THE REQUIREMENTS OF TE PRODUCT SPEC 108-10042, BASED ON EIA/ECA-364-1000.01A (CONTROLLED ENVIRONMENT APPLICATIONS).
- 3 0.76µm [.000030] MIN PRECIOUS METAL PLATE ON MATING END FOR A LENGTH OF 5.08 [.200] MIN WITH A UNIFORM GRADIENT TO 0.25µm [.000010] ON REMAINDER, OVER 1.27µm [.000050] MIN NICKEL PLATE. GOLD FLASH ALL OVER. CONFORMS TO THE REQUIREMENTS OF TE PRODUCT SPEC 108-10042, BASED ON EIA/ECA-364-1000.01A (CONTROLLED ENVIRONMENT APPLICATIONS).
- 4 0.38µm [.000015] MIN GOLD PER MIL-G-45204 ON MATING END FOR A LENGTH OF 5.08 [.200] MIN WITH 1.27µm [.000050] MIN MATTE TIN PLATE IN WIRE CRIMP AREA, BOTH OVER 1.27µm [.000050] MIN NICKEL PER QQ-N-290.
- 5 GOLD PLATING NEED NOT APPEAR IN THIS AREA.
- 6 1.27µm [.000050] MIN TIN-LEAD PER MIL-T-10727 OVER 1.27µm [.000050] MIN NICKEL PER QQ-N-290.
- 7 ALL PART NUMBERS ON THIS DRAWING HAVE APPLICATION TOOLING AVAILABLE TO CRIMP TO 18-16 AWG WIRE WITH AN INSULATION RANGE OF Ø2.03-2.54 [.080-.100] ADDITIONALLY, LOOSE PIECE AND REVERSE REELED PART NUMBERS HAVE APPLICATION TOOLING AVAILABLE TO CRIMP 0.75mm<sup>2</sup> WIRE WITH AN INSULATION RANGE OF Ø1.35-1.65 [.053-.065] OR 1.0mm<sup>2</sup> WIRE WITH AN INSULATION RANGE OF Ø1.45-1.80 [.057-.071].
- 8 0.38µm [.000015] MIN GOLD PER MIL-G-45204 ON MATING END FOR A LENGTH OF 5.08 [.200] MIN, 1.27µm [.000050] MIN TIN-LEAD PER MIL-T-10727 ON OPPOSITE END FOR A LENGTH OF 5.69 [.224] MIN, BOTH OVER 1.27µm [.000050] MIN NICKEL PER QQ-N-290.
- 9 1.27µm [.000050] MIN TIN PER MIL-T-10727 OVER 1.27µm [.000050] MIN NICKEL PER QQ-N-290.

SUPERCEDED BY 66098-8

STANDARD	9	1-66099-5	1-66098-9
1	9	1-66099-5	1-66098-8
1	8	1-66099-0	1-66098-6
1	2	66099-4	66098-9
1	4	66099-3	66098-8
1	6	66099-2	66098-7
1	3	66099-1	66098-6
STANDARD	2	66099-4	66098-4
STANDARD	4	66099-3	66098-3
STANDARD	6	66099-2	66098-2
STANDARD	3	66099-1	66098-1
REELING	PIN BODY FINISH	LOOSE PIECE REF	PART NUMBER

THIS DRAWING IS A CONTROLLED DOCUMENT.		DWN V. FURLER 19JUN2003	TE Connectivity	
DIMENSIONS: mm [INCHES]		CHK G. STEINHAUER 19JUN03		
TOLERANCES UNLESS OTHERWISE SPECIFIED:		APVD G. STEINHAUER 19JUN03	NAME	
0 PLC ± -		PRODUCT SPEC	PIN ASSEMBLY, .062, TYPE III+	
1 PLC ± -		APPLICATION SPEC	SIZE A2	CAGE CODE 00779
2 PLC ± 0.13 [.005]		WEIGHT -	DRAWING NO C-66098	RESTRICTED TO -
3 PLC ± -		CUSTOMER DRAWING	SCALE 1:1	SHEET 1 OF 1
4 PLC ± -			REV AG1	
ANGLES ± -				
FINISH				
SEE CALLOUTS		SEE TABLE		