

# ABA-53563

## 3.5 GHz Broadband Silicon RFIC Amplifier



### Data Sheet

#### Description

Avago's ABA-53563 is an economical, easy-to-use, internally 50-ohm matched silicon monolithic amplifier that offers excellent gain and flat broadband response from DC to 3.5 GHz. Packaged in an ultra-miniature industry-standard SOT-363 package, it requires half the board space of a SOT-143 package.

At 2 GHz, the ABA-53563 offers a small-signal gain of 21.5 dB, output P1dB of 12.7 dBm and 22.9 dBm output third order intercept point. It is suitable for use as buffer amplifiers for wideband applications. They are designed for low cost gain blocks in cellular applications, DBS tuners, LNB and other wireless communications systems.

ABA-53563 is fabricated using Avago's HP25 silicon bipolar process, which employs a double-diffused single polysilicon process with self-aligned submicron emitter geometry. The process is capable of simultaneous high  $f_T$  and high NPN breakdown (25 GHz  $f_T$  at 6V BVCEO). The process utilizes industry standard device oxide isolation technologies and submicron aluminum multilayer interconnect to achieve superior performance, high uniformity, and proven reliability.

#### Surface Mount Package: SOT-363 / SC70

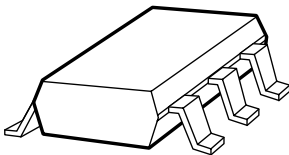

#### Pin Connections and Package Marking

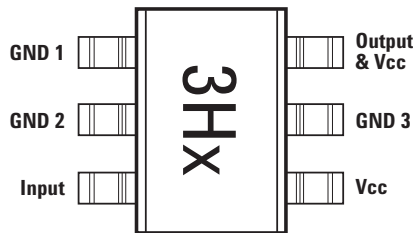

#### Note:

Top View. Package marking provides orientation and identification. "x" is character to identify date code.

#### Features

- Operating frequency: DC ~ 3.5 GHz
- 21.5 dB gain
- VSWR < 2.0 throughout operating frequency
- 12.7 dBm output P1dB
- 3.5 dB noise figure
- Unconditionally stable
- Single 5V supply (I<sub>d</sub> = 46 mA)
- Lead-free option available

#### Applications

- Amplifier for cellular, cordless, special mobile radio, PCS, ISM, wireless LAN, DBS, TVRO, and TV tuner applications



**Attention:**  
Observe precautions for handling electrostatic sensitive devices.

ESD Machine Model (Class A)

ESD Human Body Model (Class 1A)

Refer to Agilent Application Note A004R: Electrostatic Discharge Damage and Control.

#### Simplified Schematic

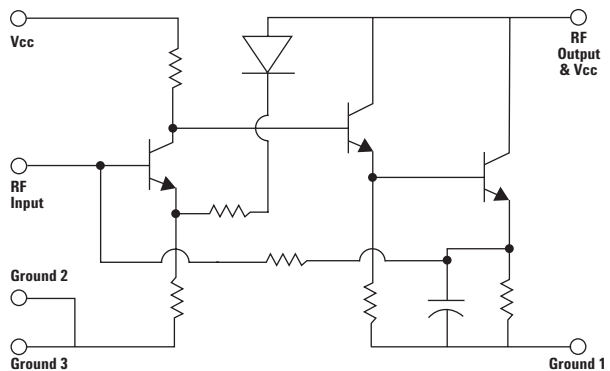

### ABA-53563 Absolute Maximum Ratings<sup>[1]</sup>

Symbol	Parameter	Units	Absolute Max.
$V_{cc}$	Device Voltage, RF output to ground (T = 25°C)	V	+7
$P_{in}$	CW RF Input Power (V <sub>cc</sub> = 5V)	dBm	+20
$P_{diss}$	Total Power Dissipation <sup>[3]</sup>	W	0.47
$T_j$	Junction Temperature	°C	150
$T_{STG}$	Storage Temperature	°C	-65 to 150

**Thermal Resistance<sup>[2]</sup> (V<sub>cc</sub> = 5V)**  
 $\theta_{jc} = 117^\circ\text{C/W}$

**Notes:**

1. Operation of this device in excess of any of these limits may cause permanent damage.
2. Thermal resistance measured using 150°C Liquid Crystal Measurement Technique.
3. Board (package belly) temperature, T<sub>b</sub>, is 25°C. Derate 5 mW/°C for T<sub>b</sub> > 94.8°C.

### Electrical Specifications

T<sub>c</sub> = +25°C, Z<sub>0</sub> = 50 Ω, P<sub>in</sub> = -30 dBm, V<sub>cc</sub> = 5V, Freq = 2 GHz, unless stated otherwise.

Symbol	Parameter and Test Condition	Units	Min.	Typ.	Max.	Std Dev.
G <sub>p</sub> <sup>[1]</sup>	Power Gain ( $ S_{21} ^2$ )	dB	20	21.5		0.2
ΔG <sub>p</sub>	Power Gain Flatness, f = 0.1 ~ 2.5 GHz f = 0.1 ~ 3.5 GHz	dB		0.6 2.7		
NF <sup>[1]</sup>	Noise Figure	dB		3.5	4	0.11
P1dB <sup>[1]</sup>	Output Power at 1dB Gain Compression	dBm		12.7		0.14
OIP3 <sup>[1]</sup>	Output Third Order Intercept Point	dBm		22.9		0.14
VSWR <sub>in</sub> <sup>[1]</sup>	Input VSWR			1.1		
VSWR <sub>out</sub> <sup>[1]</sup>	Output VSWR			1.2		
I <sub>cc</sub> <sup>[1]</sup>	Device Current	mA		46	57	0.6
t <sub>d</sub> <sup>[1]</sup>	Group Delay	ps		160		

**Notes:**

1. Measurements taken on 50Ω test board shown on Figure 1. Excess circuit losses had been de-embedded from actual measurements. Standard deviation and typical data based on at least 500 parts sample size from 6 wafer lots. Future wafers allocated to this product may have nominal values anywhere within the upper and lower spec limits.

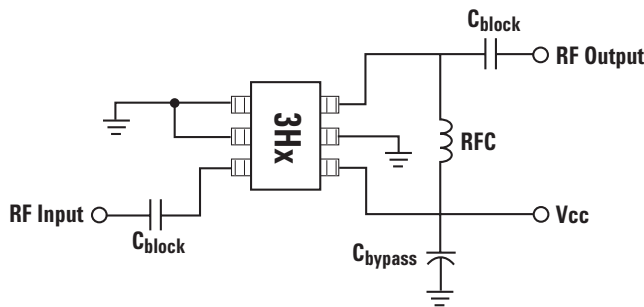

Figure 1. ABA-53563 Production Test Circuit.

## ABA-53563 Typical Performance

$T_c = +25^\circ\text{C}$ ,  $Z_o = 50\Omega$ ,  $V_{cc} = 5\text{V}$  unless stated otherwise.

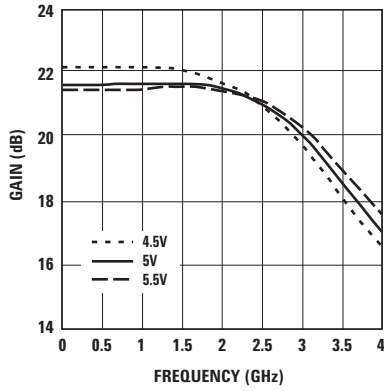

Figure 2. Gain vs. Frequency and Voltage.

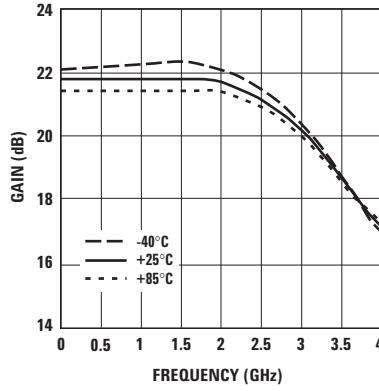

Figure 3. Gain vs. Frequency and Temperature.

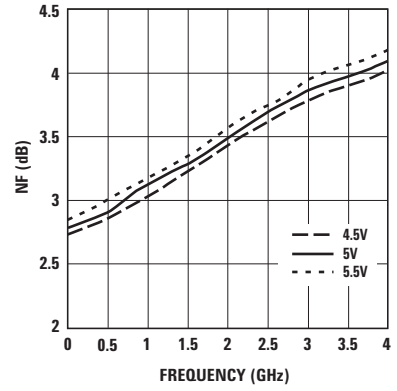

Figure 4. Noise Figure vs. Frequency and Voltage.

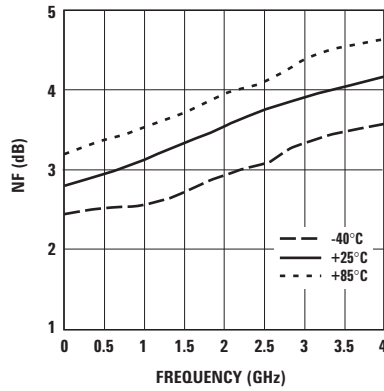

Figure 5. Noise Figure vs. Frequency and Temperature.

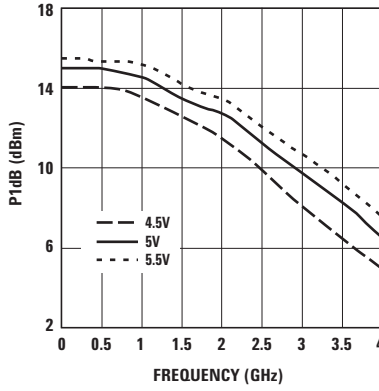

Figure 6. Output Power for 1 dB Gain Compression vs. Frequency and Voltage.

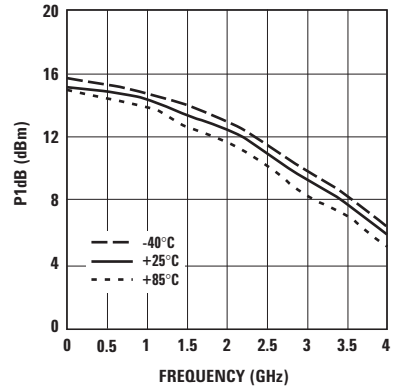
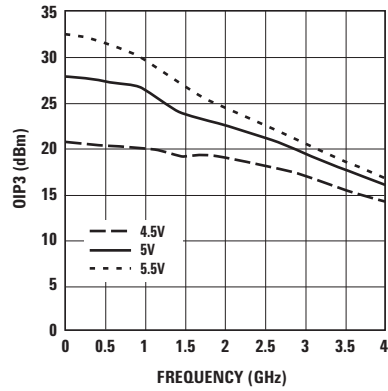

Figure 7. Output Power for 1 dB Gain Compression vs. Frequency and Temperature.

**ABA-53563 Typical Performance, continued**

$T_c = +25^\circ\text{C}$ ,  $Z_o = 50\Omega$ ,  $V_{cc} = 5\text{V}$  unless stated otherwise.



**Figure 8. Output IP3 vs. Frequency and Voltage.**

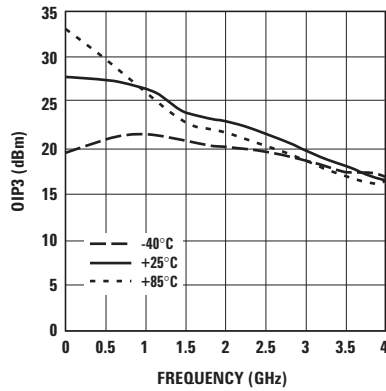

**Figure 9. Output IP3 vs. Frequency and Temperature.**

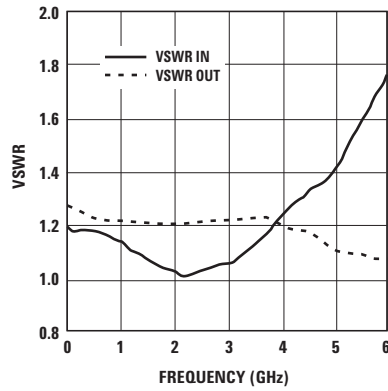

**Figure 10. Input and Output VSWR vs. Frequency.**

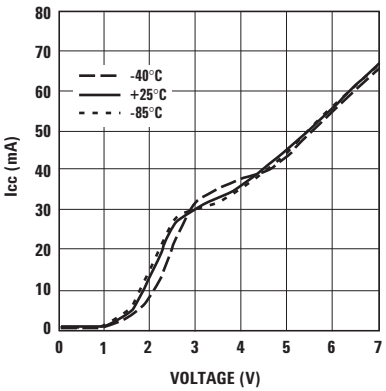

**Figure 11. Supply Current vs. Voltage and Temperature.**

### ABA-53563 Typical Scattering Parameters

T<sub>C</sub> = +25°C, V<sub>CC</sub> = 5V, Z<sub>0</sub> = 50 Ω, unless stated otherwise

Freq (GHz)	S <sub>11</sub> Mag.	S <sub>11</sub> Ang.	S <sub>21</sub> dB	S <sub>21</sub> Mag.	S <sub>21</sub> Ang.	S <sub>12</sub> dB	S <sub>12</sub> Mag.	S <sub>12</sub> Ang.	S <sub>22</sub> Mag.	S <sub>22</sub> Ang.	K Factor
0.05	0.09	169.3	21.6	11.98	-3.4	-29.4	0.03	-0.6	0.12	-2.3	1.414
0.10	0.08	165.6	21.5	11.87	-5.9	-29.4	0.03	-0.7	0.12	-5.8	1.424
0.20	0.08	164.9	21.5	11.85	-10.5	-29.6	0.03	-0.8	0.12	-11.7	1.458
0.30	0.08	164.3	21.5	11.85	-15.4	-29.6	0.03	-0.4	0.11	-16.5	1.458
0.40	0.08	162.9	21.5	11.86	-20.4	-29.9	0.03	0.1	0.11	-20.5	1.491
0.50	0.08	163.8	21.5	11.90	-25.5	-29.9	0.03	0.8	0.10	-23.8	1.489
0.60	0.08	162.4	21.5	11.89	-30.5	-29.9	0.03	1.7	0.10	-27.2	1.490
0.70	0.08	159.6	21.5	11.90	-35.6	-29.9	0.03	2.5	0.10	-30.9	1.490
0.80	0.08	158.1	21.5	11.92	-40.6	-29.9	0.03	3.4	0.10	-34.6	1.488
0.90	0.07	158.6	21.5	11.92	-45.7	-29.9	0.03	4.5	0.10	-36.7	1.489
1.00	0.07	158.3	21.5	11.95	-50.9	-29.9	0.03	5.5	0.10	-39.1	1.487
1.20	0.05	149.9	21.6	12.00	-61.3	-29.9	0.03	7.7	0.10	-41.7	1.483
1.40	0.04	147.4	21.6	12.04	-71.9	-29.6	0.03	9.5	0.10	-42.7	1.448
1.60	0.03	139.0	21.6	12.06	-83.0	-29.6	0.03	11.5	0.09	-43.3	1.446
1.80	0.02	127.0	21.6	12.01	-94.4	-29.4	0.03	13.0	0.09	-42.3	1.420
2.00	0.01	94.0	21.5	11.89	-105.8	-28.9	0.04	14.5	0.09	-38.8	1.374
2.20	0.01	-22.9	21.4	11.77	-117.4	-29.6	0.04	15.4	0.09	-36.3	1.356
2.40	0.01	-49.8	21.2	11.53	-129.2	-28.4	0.04	15.8	0.10	-34.4	1.348
2.60	0.02	-83.6	21.0	11.21	-141.1	-28.0	0.04	15.8	0.10	-33.9	1.327
2.80	0.03	-95.4	20.7	10.79	-153.1	-27.7	0.04	16.4	0.10	-33.7	1.338
3.00	0.03	-112.0	20.2	10.25	-164.9	-27.5	0.04	16.9	0.10	-32.1	1.362
3.20	0.04	-128.4	19.7	9.68	-176.1	-26.9	0.05	16.8	0.10	-28.9	1.348
3.40	0.06	-146.0	19.2	9.08	173.1	-26.6	0.05	16.2	0.10	-30.1	1.364
3.50	0.06	-152.9	18.9	8.78	167.7	-26.4	0.05	16.0	0.10	-30.9	1.373
4.00	0.11	170.6	17.4	7.41	143.3	-25.8	0.05	14.1	0.09	-38.3	1.477
4.50	0.14	137.6	16.0	6.30	120.2	-24.7	0.06	12.9	0.08	-41.5	1.505
5.00	0.17	122.9	14.3	5.21	99.1	-23.9	0.06	10.0	0.05	-57.3	1.612
5.50	0.23	110.6	13.0	4.47	80.1	-22.9	0.07	5.1	0.04	-82.0	1.624
6.00	0.28	99.6	11.8	3.88	63.4	-22.0	0.08	-0.2	0.04	-142.5	1.656

## Device Models

Refer to Avago's web site  
www.avagotech.com/view/rf

## Ordering Information

Part Number	Devices per Container	Container
ABA-53563-TR1	3000	7" reel
ABA-53563-TR2	10000	13" reel
ABA-53563-BLK	100	antistatic bag
ABA-53563-TR1G	3000	7" reel
ABA-53563-TR2G	10000	13" reel
ABA-53563-BLKG	100	antistatic bag

Note: For lead-free option, the part number will have the character "G" at the end.

## Package Dimensions

### Outline 63 (SOT-363/SC-70)

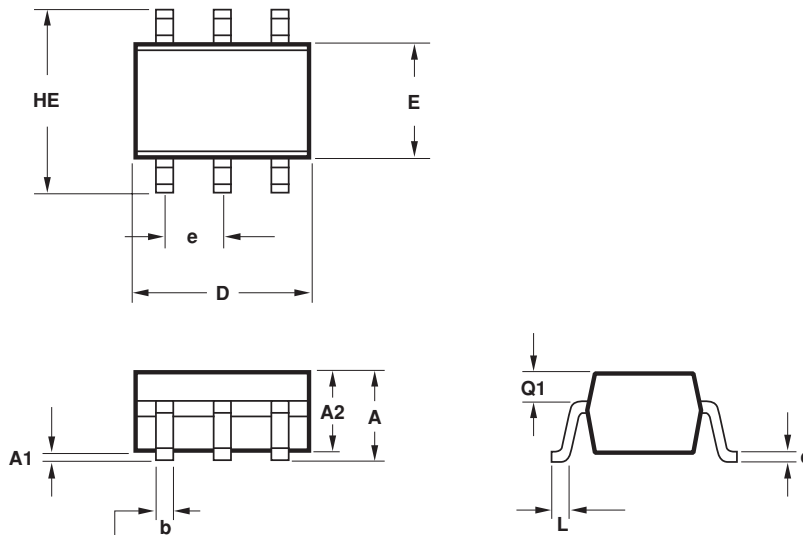

### Recommended PCB Pad Layout for Avago's SC70 6L/SOT-363 Products

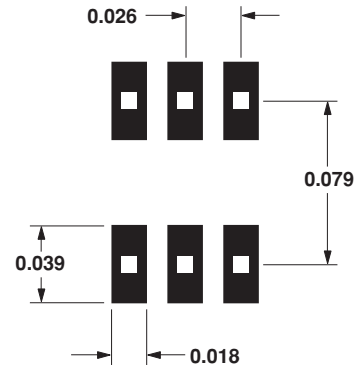

Dimensions in inches.

SYMBOL	DIMENSIONS (mm)	
	MIN.	MAX.
E	1.15	1.35
D	1.80	2.25
HE	1.80	2.40
A	0.80	1.10
A2	0.80	1.00
A1	0.00	0.10
Q1	0.10	0.40
e	0.650 BCS	
b	0.15	0.30
c	0.10	0.20
L	0.10	0.30

#### NOTES:

- All dimensions are in mm.
- Dimensions are inclusive of plating.
- Dimensions are exclusive of mold flash & metal burr.
- All specifications comply to EIAJ SC70.
- Die is facing up for mold and facing down for trim/form, ie: reverse trim/form.
- Package surface to be mirror finish.

## Device Orientation

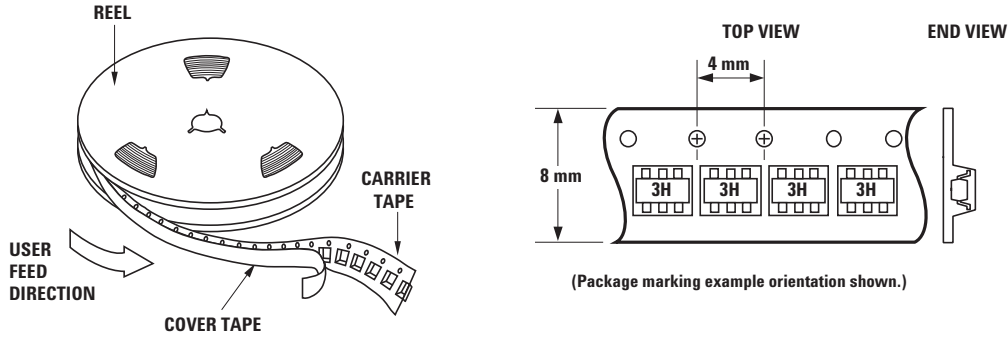

## Tape Dimensions and Product Orientation for Outline 63

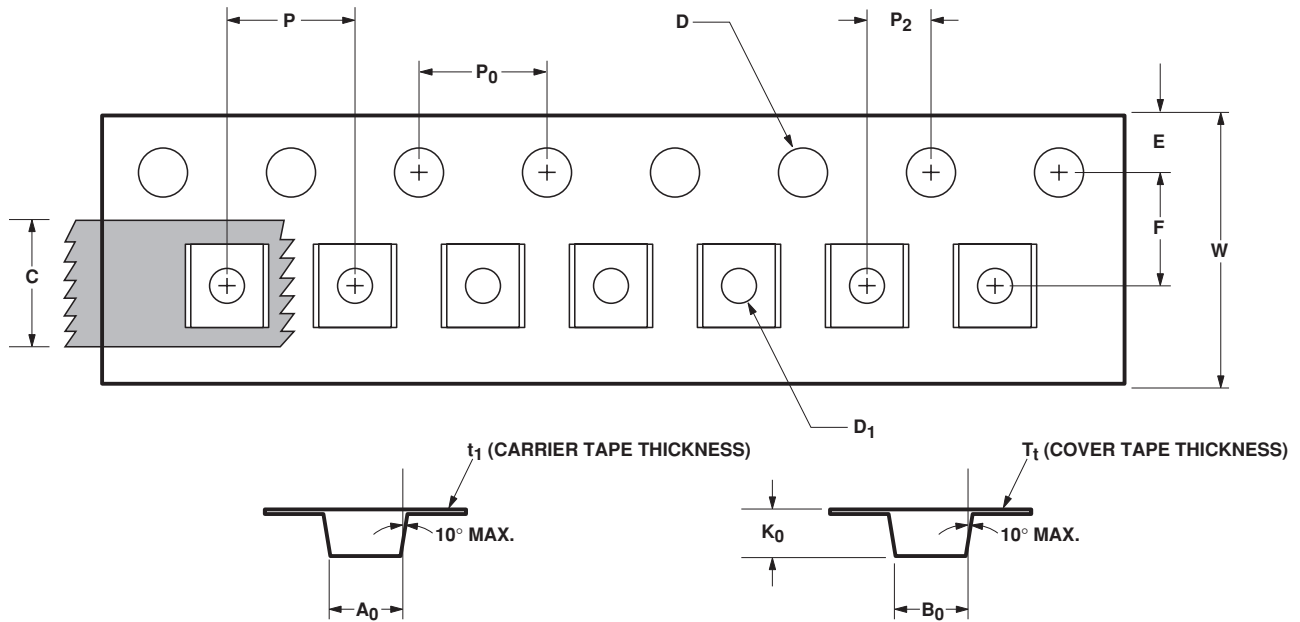

DESCRIPTION		SYMBOL	SIZE (mm)	SIZE (INCHES)
CAVITY	LENGTH	A <sub>0</sub>	2.40 ± 0.10	0.094 ± 0.004
	WIDTH	B <sub>0</sub>	2.40 ± 0.10	0.094 ± 0.004
	DEPTH	K <sub>0</sub>	1.20 ± 0.10	0.047 ± 0.004
	PITCH	P	4.00 ± 0.10	0.157 ± 0.004
	BOTTOM HOLE DIAMETER	D <sub>1</sub>	1.00 + 0.25	0.039 + 0.010
PERFORATION	DIAMETER	D	1.50 ± 0.10	0.061 + 0.002
	PITCH	P <sub>0</sub>	4.00 ± 0.10	0.157 ± 0.004
	POSITION	E	1.75 ± 0.10	0.069 ± 0.004
CARRIER TAPE	WIDTH	W	8.00 + 0.30 - 0.10	0.315 + 0.012
	THICKNESS	t <sub>1</sub>	0.254 ± 0.02	0.0100 ± 0.0008
COVER TAPE	WIDTH	C	5.40 ± 0.10	0.205 + 0.004
	TAPE THICKNESS	T <sub>t</sub>	0.062 ± 0.001	0.0025 ± 0.0004
DISTANCE	CAVITY TO PERFORATION (WIDTH DIRECTION)	F	3.50 ± 0.05	0.138 ± 0.002
	CAVITY TO PERFORATION (LENGTH DIRECTION)	P <sub>2</sub>	2.00 ± 0.05	0.079 ± 0.002

For product information and a complete list of distributors, please go to our web site:  
**[www.avagotech.com](http://www.avagotech.com)**

Avago, Avago Technologies, and the A logo are trademarks of Avago Technologies, Pte.  
in the United States and other countries.  
Data subject to change. Copyright © 2006 Avago Technologies Pte. All rights reserved.  
Obsoletes 5989-0952EN  
5989-1972EN March 31, 2006

