

Features

- Integral TTL Driver
- Ultra Low Power Consumption
- Fast Switching Speed: 4 ns Typical
- Hermetic Surface Mount Package
- 50 Ohm Nominal Impedance
- MIL-STD-883 Screening Available
- Lead-Free CR-9 Package
- 260°C Reflow Compatible
- RoHS* Compliant

Description

M/A-COM's SW-311-PIN is a GaAs FET SPST absorptive switch with integral silicon ASIC driver. Packaged in a 16-lead ceramic surface mount package, this device offers excellent performance and repeatability from DC to 3 GHz while maintaining low power consumption. The SW-311-PIN is ideally suited for use where fast speed, low power consumption and broadband applications are required. MIL-STD-883 Screening Available.

Functional Block Diagram

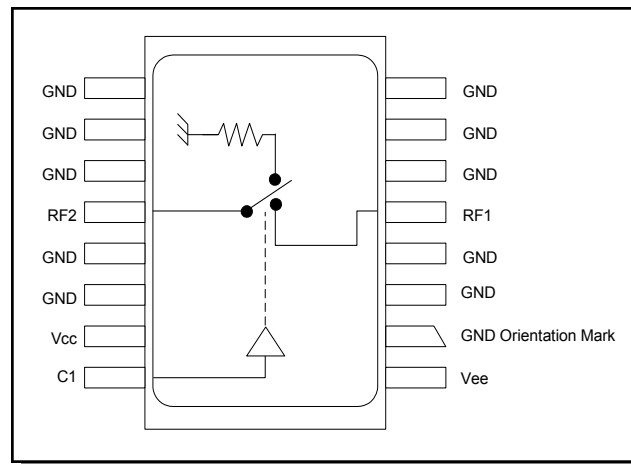

Ordering Information

Part Number	Package
SW-311-PIN	Bulk Packaging
MASW-008845-0001TB	Sample Test Board

Note: Reference Application Note M513 for reel size information.

Pin Configuration

Pin No.	Function	Pin No.	Function
1	Vee	9	GND
2	GND	10	GND
3	GND	11	GND
4	GND	12	RF2
5	RF1	13	GND
6	GND	14	GND
7	GND	15	Vcc
8	GND	16	C1

The metal bottom of the case must be connected to RF and DC ground.

* Restrictions on Hazardous Substances, European Union Directive 2002/95/EC.

SW-311-PIN



Match GaAs SPST Switch,
DC-3.0 GHz with TTL/CMOS Control Input

Rev. V7

Electrical Specifications: (From -55°C to $+85^{\circ}\text{C}$), $Z_0 = 50\Omega$ ^{1,2}

Parameter	Test Conditions	Frequency	Units	Min	Typ	Max
Insertion Loss	—	DC - 3000 MHz	dB	—	—	1.3
		DC - 2000 MHz	dB	—	—	1.2
		DC - 1000 MHz	dB	—	—	1.0
		DC - 500 MHz	dB	—	—	0.8
VSWR	—	DC - 3000 MHz	Ratio	—	—	1.5:1
		DC - 2000 MHz	Ratio	—	—	1.4:1
		DC - 1000 MHz	Ratio	—	—	1.3:1
		DC - 500 MHz	Ratio	—	—	1.2:1
Isolation	—	DC - 3000 MHz	dB	27	—	—
		DC - 2000 MHz	dB	36	—	—
		DC - 1000 MHz	dB	50	—	—
		DC - 500 MHz	dB	65	—	—
Trise, Tfall	10% to 90%	—	ns	—	4	—
Ton, Toff	1.3V CTL to 90% / 10%	—	ns	—	12	—
Transients	In-Band	—	mV	—	40	—
1 dB Compression	Input Power	0.05 GHz	dBm	—	+21	—
		0.5 GHz to 3 GHz	dBm	—	+27	—
IP2	Two-Tone Input Power up to +5 dBm	0.05 GHz	dBm	—	+62	—
		0.5 GHz to 3 GHz	dBm	—	+68	—
IP3	Two-Tone Input Power up to +5 dBm	0.05 GHz	dBm	—	+40	—
		0.5 GHz to 3 GHz	dBm	—	+46	—
Vin Low	0V to 0.8V	—	μA	—	—	1
Vin High	2.0V to 5.0V	—	μA	—	—	1
Vcc	+5.0V \pm 10%	—	mA	—	—	1
Vee	-5.0V to -8.0V	—	mA	—	—	1

1. All specifications apply when operated with bias voltages of +5V for Vcc and -5V for Vee.
2. When DC blocks are used, a 10K ohm return to GND is required on the RFC port.

Absolute Maximum Ratings ^{3,4}

Parameter	Absolute Maximum
Max Input Power 50 MHz 500 - 3000 MHz	+27 dBm +34 dBm
V_{CC}	$-0.5V \leq V_{CC} \leq +7.0V$
V_{EE}	$-8.5V \leq V_{EE} \leq +0.5V$
$V_{CC} - V_{EE}$	$-0.5V \leq V_{CC} - V_{EE} \leq 14.5V$
V_{in}^5	$-0.5V \leq V_{in} \leq V_{CC} + 0.5V$
Operating Temperature	-55°C to +125°C
Storage Temperature	-65°C to +150°C

- Exceeding any one or combination of these limits may cause permanent damage to this device.
- M/A-COM does not recommend sustained operation near these survivability limits.
- Standard CMOS TTL interface, latch-up will occur if logic signal is applied prior to power supply.

Handling Procedures

Please observe the following precautions to avoid damage:

Static Sensitivity

Gallium Arsenide Integrated Circuits are sensitive to electrostatic discharge (ESD) and can be damaged by static electricity. Proper ESD control techniques should be used when handling these devices.

Truth Table (Switch)

Control Input	Condition of Switch
C1	RF1 to RF2
0	ON
1	OFF

0 = TTL Low; 1 = TTL High

Typical Performance Curves

Insertion Loss vs. Frequency

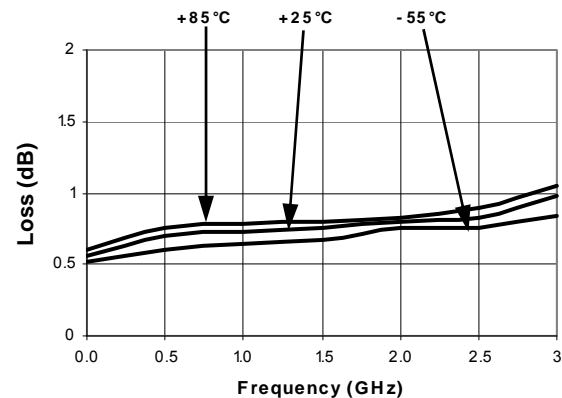

VSWR vs. Frequency

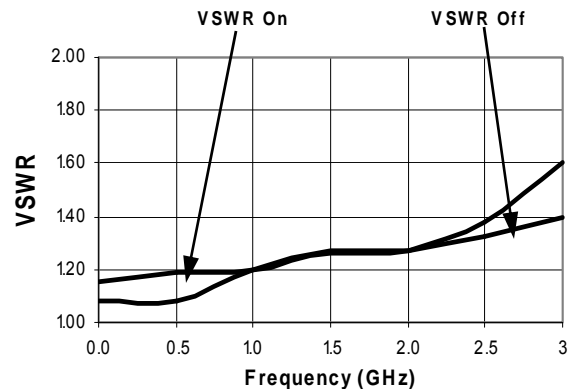

Isolation vs. Frequency

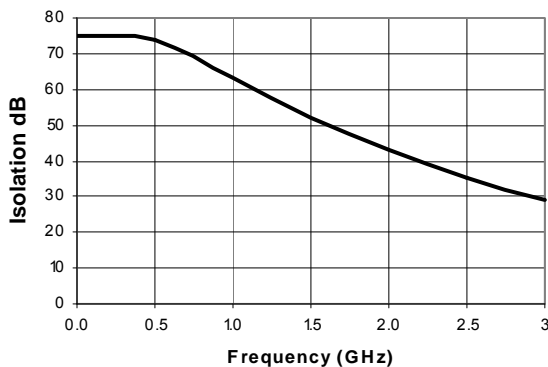

SW-311-PIN

Match GaAs SPST Switch,
DC-3.0 GHz with TTL/CMOS Control Input

Rev. V7

Lead-Free CR-9 Ceramic Package[†]

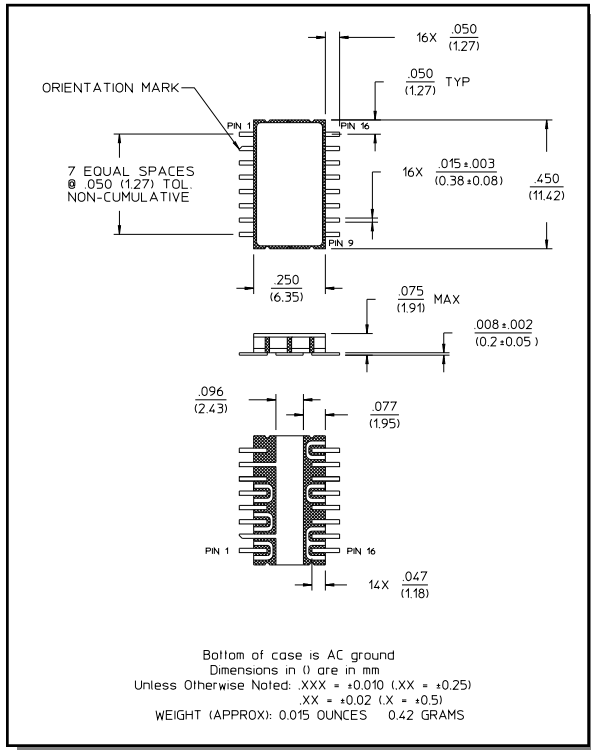

[†] Reference Application Note M538 for lead-free solder reflow recommendations.