

AN-1823 LM3528 Evaluation Board

1 Introduction

The LM3528 is an asynchronous boost converter with two separate outputs. The first output (MAIN) is a constant current source for driving up to six series white LED's. The second output (SUB) is configurable as a constant current source for driving up to six series white LEDs, or as a feedback input to set a constant supply voltage for organic light-emitting diode (OLED) panel power. The maximum LED current per output is set via a single external low power resistor. An I²C compatible interface allows for independent adjustment of the LED current in either output from 0 to max current in 128 exponential steps. When configured as a white LED + OLED bias supply the LM3528 can independently and simultaneously drive a string of up to six white LED's and deliver a constant output voltage of up to 21 V for OLED panels.

The evaluation board is set up to drive two strings of six white LEDs (Nichia , NSSW008C, $V_F = 3.2\text{ V}$ at 20 mA). These are set up with six LEDs in the MAIN string and six LEDs in the SUB string. Alternatively, resistors can be installed in the R1 and R2 pads to make the device a voltage output boost converter for OLED display powering (see the output voltage setting OLED mode).

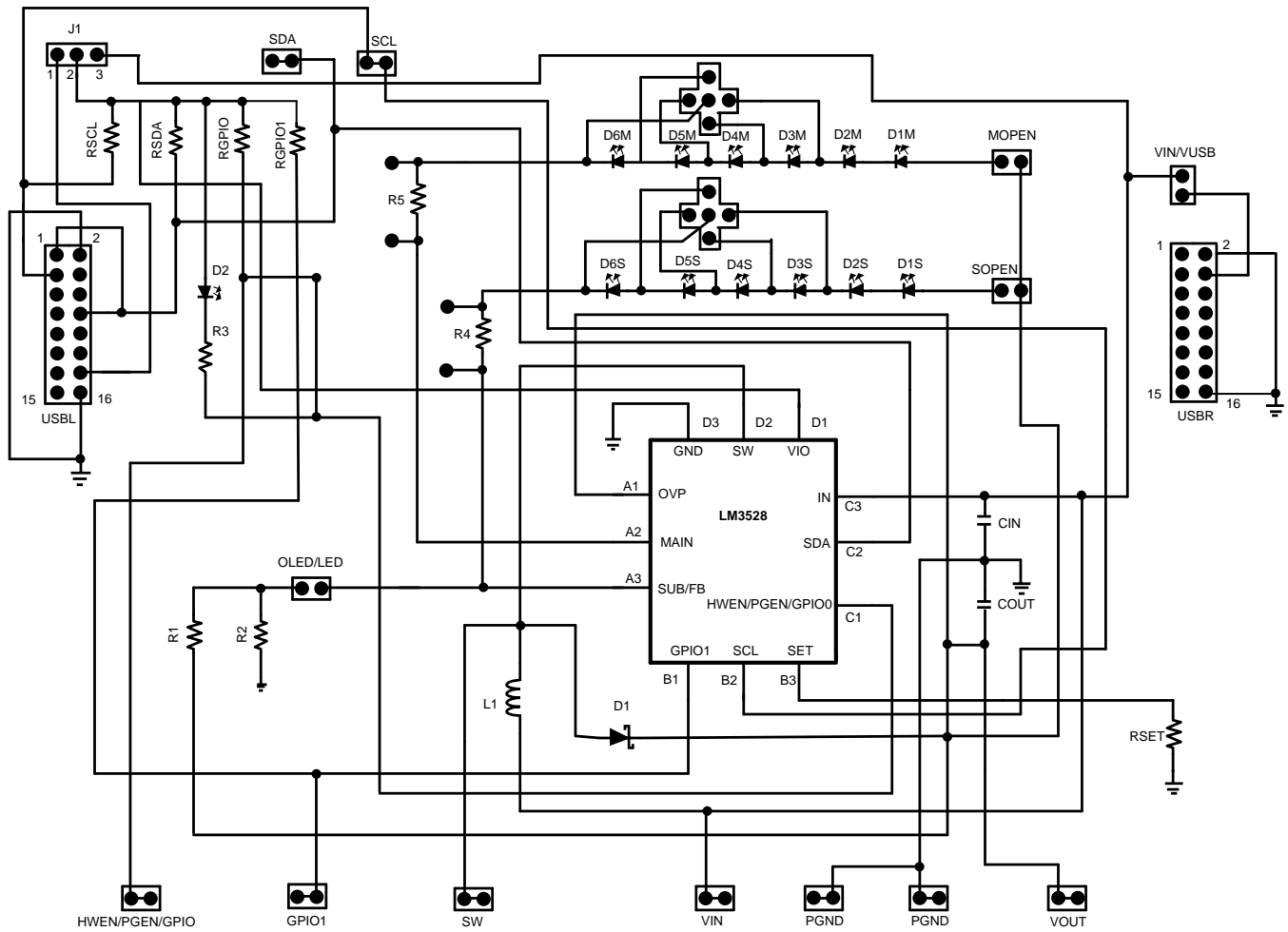

Figure 1. LM3528 Evaluation Board Schematic

2 LM3528 Evaluation Board Bill of Materials (BOM)

Texas Instruments	Silicon Revision	Package Mark	Package
LM3528	A1	SE	TMD12AAA

Table 1. Board Bill of Materials

Component Symbol	Value	Mfr.	Part No
L1	10 μ H, $I_{SAT} = 790$ mA	TDK	VLF4012AT-100MR79
CIN	1 μ F, 10 V	TDK	C1608JB1A105M
COUT	1 μ F, 25 V	TDK	C1608JB1E105M
D1M-D6M	White LED	Nichia	NSSW008C
D1S-D6S	White LED	Nichia	NSSW008C
RSDA	10 k Ω	Vishay	CRCW06031002F
RSCL	10 k Ω	Vishay	CRCW06031002F
RPU	1 M Ω	Vishay	CRCW06031004F
D1	Schottky, 500 mA	Diodes Incorporated	SDM20U30 (SOD-523)
D2	Red LED	Stanley Electric	HKR1105W
R1	Not Installed		
R2	Not Installed		
R3	205 Ω	Vishay	CRCW06032050F
R4	0 Ω	Vishay	CRCW0603
R5	0 Ω	Vishay	CRCW0603
RSET	12.1k Ω	Vishay	CRCW06031212F

3 LM3528 Evaluation Board Layout

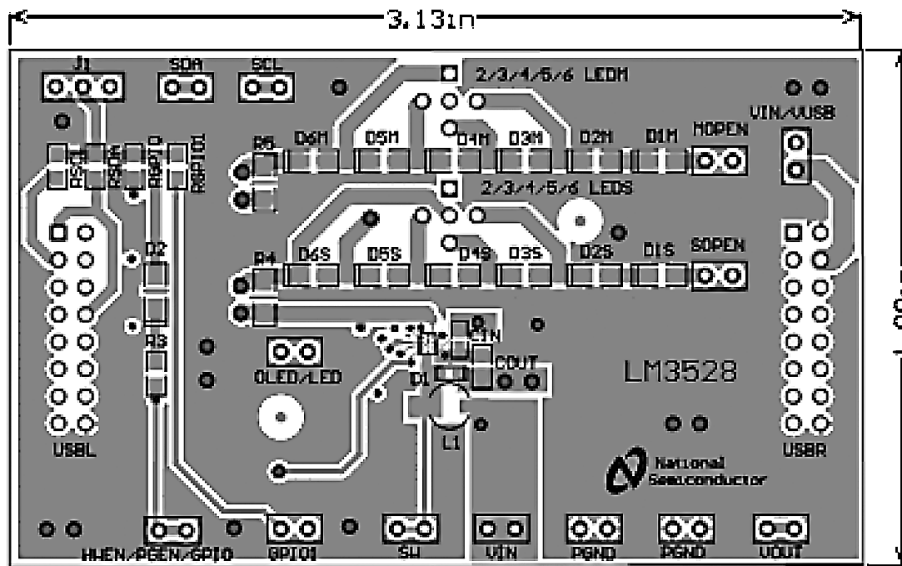

Figure 2. Top View (Board Layout)

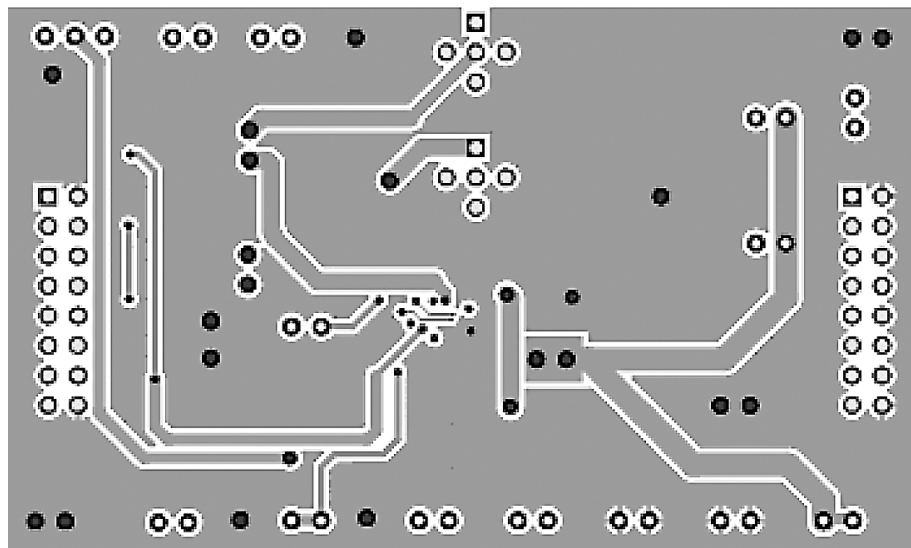

Figure 3. Mid Layer 1 (Board Layout)

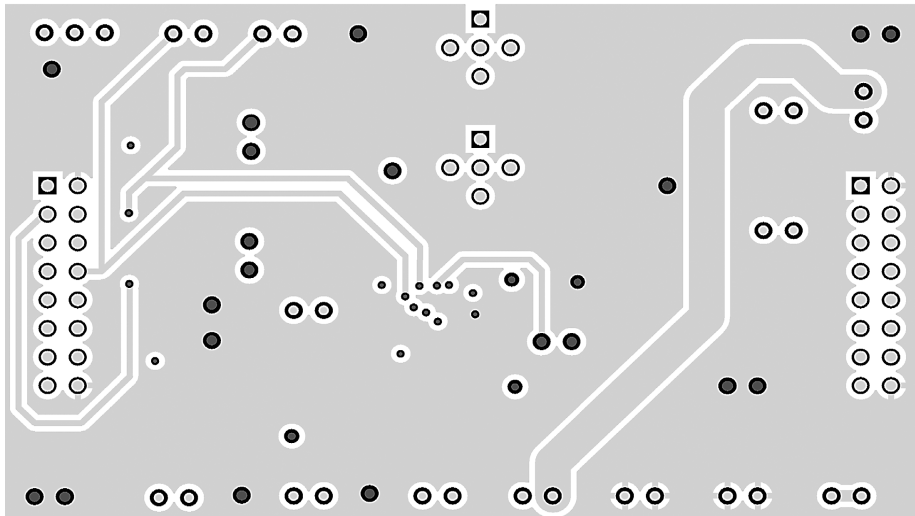

Figure 4. Mid Layer 2(Board Layout)

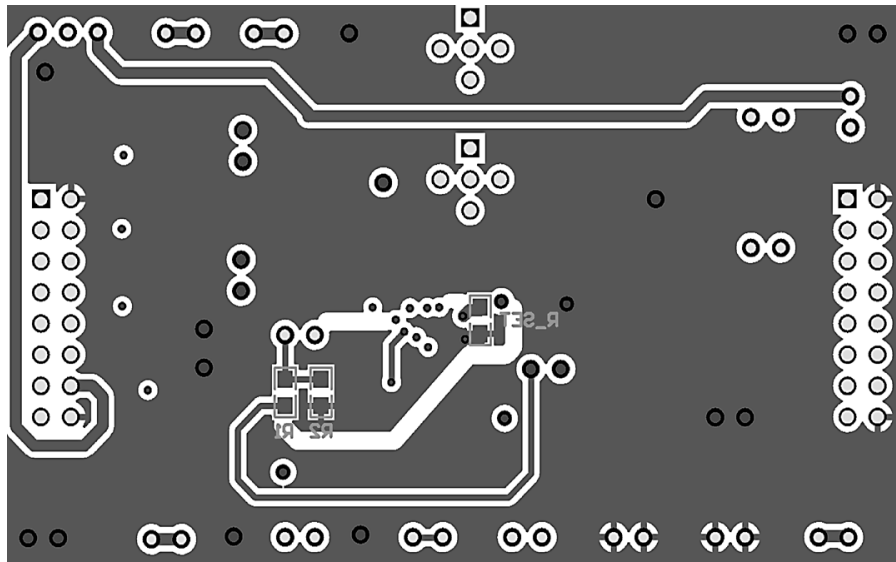

Figure 5. Bottom View (Board Layout)

4 Board Operation

To operate the LM3528 evaluation board, connect a 2.5 V to 5.5 V supply between the IN header and GND and attach an I²C interface using one of the methods described in [Section 5](#).

5 External Control Interface

There are two methods for controlling the LM3528 evaluation board. The first option is via a Texas Instruments USB interface board. The second option is by using the SDA and SCL headers available on the upper left corner of the board. When option 1 is used, the USBL and USBR connectors plug directly into a Texas Instruments USB interface board. The connectors are keyed so they will only fit one way. On the LM3528 evaluation board the V_{IN}/USB jumper allows for power to come from IN or from the USB .

The USB board can supply 3.3 V from an on board regulator or 5 V directly from the PC (see documentation for the Texas Instruments USB interface board). When power from the USB is desired connect a jumper across V_{IN}/V_{USB} , if power is supplied from the IN header leave V_{IN}/V_{USB} open. DO NOT jumper V_{IN}/V_{USB} while an external source is connected to IN as this will make a conflict between the USB board and the external power supply.

The USB interface board interfaces directly with the LM3528.exe graphical interface via the PC, see [Section 7](#). If the LM3528.exe program is not used, control of the LM3528 evaluation board can be done by connecting an external I²C compatible interface directly to the SCL and SDA headers. Both the SDA and SCL lines have 10 k Ω pull-ups installed on the board.

6 Basic Connections (see [Figure 1](#))

The LM3528 evaluation board is configured for two strings of six LEDs. There are two resistor pads on the bottom side of the board, R1 and R2, that serve as feedback resistors for the operation of the LM3528 in voltage output mode (OLED mode). When operating in OLED mode (with D1S – D6S installed), the OLED/LED jumper must be installed in order to connect the center tap of the resistive divider (R1 and R2) to the SUB/FB pin. Additionally (in OLED mode), the SOPEN header should be removed, otherwise, the secondary LED string interferes with the feedback divider and causes erratic operation.

6.1 Jumper Connections/Component Descriptions

- J1 is a 3-pin, 3-position jumper. The leftmost pin (pin 1 in [Figure 1](#)) connects to the 3.3 V supply from the USB board (pin 14 on the USBL connector). The rightmost pin (pin 3 in [Figure 1](#)) connects to IN. The top middle pin (pin 2 in [Figure 1](#)) connects to VIO of the LM3528, the top side of the pull-up resistors (RSDA, RSCL, RGPI0, RGPI01), and the anode of the indicator diode D2.
- The SOPEN and MOPEN jumpers allow for the disconnection of the LEDs from the LM3528's output. SOPEN opens the SECONDARY (SUB/FB) LED string while MOPEN opens the MAIN LED string. This is useful in testing OVP or disabling a string if OLED mode is required.
- The 5-pin, 5-position jumpers (2/3/4/5/6 LEDM and 2/3/4/5/6 LEDS) located above the MAIN and SECONDARY LED strings, respectively, allow for shorting out of different LEDs in both the MAIN and the SECONDARY strings. Both jumpers have their center pin (pin 5 in [Figure 1](#)) connected to the cathode of the sixth LED in each string. Referring to jumper 2/3/4/5/6 LEDS, connecting pin 4 to pin 5 will short D6S, thus, making the SECONDARY string a five-LED configuration. Connect pin 3 to pin 5 to short D5S and D6S resulting in a four-LED configuration. Connect pin 2 to pin 5 for a three-LED configuration (D4S – D6S shorted). Connect pin 1 to pin 5 for a two-LED configuration (D3S – D6S shorted), and leave jumper 2/3/4/5/6 LEDS open for a six-LED configuration. The operation for jumper 2/3/4/5/6 LEDM is the same, only it applies to the MAIN LED string.
- Resistors R4 and R5 have 0 Ω 's across them. The 0 Ω resistors can be replaced with current sense resistors for measuring LED current. Two vias have been placed at the terminals of each resistor, which fit standard 0.1" headers.
- The OLED/LED jumper connects or disconnects the resistive divider from the SUB/FB node. In white LED mode, the jumper should be open. In OLED mode, the jumper should be shorted so the SUB/FB node can regulate V_{OUT} at a constant voltage.
- D2 is a RED indicator diode that flashes the programmed pattern programmed into the PGEN registers (see the *LM3528 High Efficiency, Multi Display LED Driver With 128 Exponential Dimming Steps and Integrated OLED Power Supply in a 1.2mm x 1.6mm DSBGA Package Data Sheet (SNVS513)*). R3 is a 205 Ω current limiting resistor for D2. RGPI0 is a 1 M Ω pull-up resistor for the HWEN/PGEN/GPI0 output. On power up, the HWEN/PGEN/GPI0 output defaults as an active high hardware enable (HWEN). RGPI0 is installed to ensure that HWEN/PGEN/GPI0 pulls high on start-up.

7 LM3528–USB Interface Board and I²C Compatible Interface Program

In order to fully evaluate the LM3528, the use of an "I²C Compatible" interface must be used for any functionality to occur. The detailed description regarding the interface control, the LM3528 registers, and OLED mode is described in the *LM3528 High Efficiency, Multi Display LED Driver With 128 Exponential Dimming Steps and Integrated OLED Power Supply in a 1.2mm x 1.6mm DSBGA Package Data Sheet (SNVS513)*.

TI has created an I²C-compatible program (see [Figure 6](#)) and a USB interface board that can help exercise the part in a simple way. The LM3528 evaluation board has the means to “plug into” the USB interface board. The USB interface board provides all of the control signals for the simple interface and can provide power to the part as well. A jumper on the LM3528 evaluation board labeled V_{IN}/VUSB allows you to connect either an external power supply to the V_{IN} header on the LM3528 evaluation board, or draw power from the USB board. Removal of the jumper disables the connection of the USB power supply. Once removed, an external supply is required. If the jumper is installed, the USB board supplies power to the LM3528 evaluation board. No adjustments to the USB board are needed. A standard USB cable must be connected to the board from a PC in order to communicate with the LM3528 Evaluation Kit.

For proper operation, the USB interface board must be plugged into the PC before the LM3528.exe interface program is opened. Once connected, and the program is executed, a basic interface window will open. At the top of the interface, you can read or write to any of the data registers on the LM3528 using the two pull down menus for the slave I.D. and the desired data address. The data field to the right of the address pull-down menu accepts hex data while the read and write buttons directly below the Address pull-down menu execute the Read or Write command.

Just below the Read and Write buttons are five enable buttons. Two dedicated enable bits (ENM and ENS) enable the two LED strings (MAIN and SUB). A dedicated bit (UNI) enables the Unison Mode of the two LED banks, and another bit (OLED) puts the part in OLED mode. The Enable All button simultaneously enables both ENS and ENM.

Below the Enable buttons are two sliding bars and data fields that allow all 128 levels of brightness for the MAIN and SUB banks. Just below the two brightness level slider bars are six convenient action buttons: three set buttons and three reset buttons.

SetM sets the MAIN brightness level to full-scale and enables the MAIN bank.

ResetM resets the MAIN brightness level to zero and disables the MAIN bank.

SetS sets the SUB brightness level to full-scale and enables the SUB bank.

ResetS resets the SUB brightness level to zero and disables the SUB bank.

Set sets the MAIN and the SUB brightness levels to full scale and enables the MAIN and SUB banks.

Reset resets the MAIN and SUB brightness levels to zero and disables the MAIN and SUB banks.

To the right of the two brightness level slider bars is a pull-down menu that controls the ramp rate of the brightness level. To the left of the two brightness level slider bars are convenient controls for the GPIO1 pin and the HWEN/PGEN/GPIO pin.

The HWEN/PGEN/GPIO pin has three functions: an active high hardware enable (HWEN), a pattern generator output (PGEN), and a general purpose I/O (GPIO). At the bottom of the user interface are button controls for creating the output pattern when HWEN/PGEN/GPIO is in PGEN mode. For a detailed explanation of the pattern generator, see the *LM3528 High Efficiency, Multi Display LED Driver With 128 Exponential Dimming Steps and Integrated OLED Power Supply in a 1.2mm x 1.6mm DSBGA Package Data Sheet* ([SNVS513](#)). The output pattern is determined by the concatenation of four 8-bit data registers: x90, x91, x92 and x93. Each bit for each of these data registers can be set in the user interface (Byte 0 – Byte 3). The hex value of the data register is displayed to the right of the data bits in a data field. To the right of the register data fields are convenient buttons to set all the bits to 1’s or reset all the bits to 0’s.

Once you have selected the desired pattern, load the pattern into the LM3528 by clicking the “Load” button. Once the output pattern has been loaded, select the bit period and duty cycle of the pattern using the pull-down menus. Finally, the output pattern is executed by clicking the “Run” button.

NOTE: If the part is enabled to any brightness level and the program is closed, the LM3528 part will remain in the last programmed state.

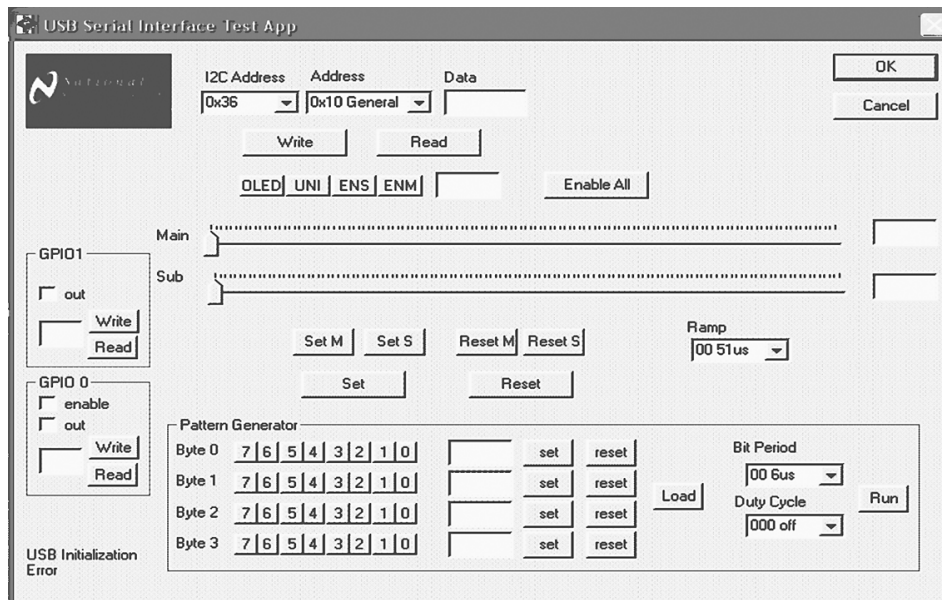

Figure 6. LM3528.exe

IMPORTANT NOTICE

Texas Instruments Incorporated and its subsidiaries (TI) reserve the right to make corrections, enhancements, improvements and other changes to its semiconductor products and services per JESD46, latest issue, and to discontinue any product or service per JESD48, latest issue. Buyers should obtain the latest relevant information before placing orders and should verify that such information is current and complete. All semiconductor products (also referred to herein as "components") are sold subject to TI's terms and conditions of sale supplied at the time of order acknowledgment.

TI warrants performance of its components to the specifications applicable at the time of sale, in accordance with the warranty in TI's terms and conditions of sale of semiconductor products. Testing and other quality control techniques are used to the extent TI deems necessary to support this warranty. Except where mandated by applicable law, testing of all parameters of each component is not necessarily performed.

TI assumes no liability for applications assistance or the design of Buyers' products. Buyers are responsible for their products and applications using TI components. To minimize the risks associated with Buyers' products and applications, Buyers should provide adequate design and operating safeguards.

TI does not warrant or represent that any license, either express or implied, is granted under any patent right, copyright, mask work right, or other intellectual property right relating to any combination, machine, or process in which TI components or services are used. Information published by TI regarding third-party products or services does not constitute a license to use such products or services or a warranty or endorsement thereof. Use of such information may require a license from a third party under the patents or other intellectual property of the third party, or a license from TI under the patents or other intellectual property of TI.

Reproduction of significant portions of TI information in TI data books or data sheets is permissible only if reproduction is without alteration and is accompanied by all associated warranties, conditions, limitations, and notices. TI is not responsible or liable for such altered documentation. Information of third parties may be subject to additional restrictions.

Resale of TI components or services with statements different from or beyond the parameters stated by TI for that component or service voids all express and any implied warranties for the associated TI component or service and is an unfair and deceptive business practice. TI is not responsible or liable for any such statements.

Buyer acknowledges and agrees that it is solely responsible for compliance with all legal, regulatory and safety-related requirements concerning its products, and any use of TI components in its applications, notwithstanding any applications-related information or support that may be provided by TI. Buyer represents and agrees that it has all the necessary expertise to create and implement safeguards which anticipate dangerous consequences of failures, monitor failures and their consequences, lessen the likelihood of failures that might cause harm and take appropriate remedial actions. Buyer will fully indemnify TI and its representatives against any damages arising out of the use of any TI components in safety-critical applications.

In some cases, TI components may be promoted specifically to facilitate safety-related applications. With such components, TI's goal is to help enable customers to design and create their own end-product solutions that meet applicable functional safety standards and requirements. Nonetheless, such components are subject to these terms.

No TI components are authorized for use in FDA Class III (or similar life-critical medical equipment) unless authorized officers of the parties have executed a special agreement specifically governing such use.

Only those TI components which TI has specifically designated as military grade or "enhanced plastic" are designed and intended for use in military/aerospace applications or environments. Buyer acknowledges and agrees that any military or aerospace use of TI components which have **not** been so designated is solely at the Buyer's risk, and that Buyer is solely responsible for compliance with all legal and regulatory requirements in connection with such use.

TI has specifically designated certain components as meeting ISO/TS16949 requirements, mainly for automotive use. In any case of use of non-designated products, TI will not be responsible for any failure to meet ISO/TS16949.

Products

Audio	www.ti.com/audio
Amplifiers	amplifier.ti.com
Data Converters	dataconverter.ti.com
DLP® Products	www.dlp.com
DSP	dsp.ti.com
Clocks and Timers	www.ti.com/clocks
Interface	interface.ti.com
Logic	logic.ti.com
Power Mgmt	power.ti.com
Microcontrollers	microcontroller.ti.com
RFID	www.ti-rfid.com
OMAP Applications Processors	www.ti.com/omap
Wireless Connectivity	www.ti.com/wirelessconnectivity

Applications

Automotive and Transportation	www.ti.com/automotive
Communications and Telecom	www.ti.com/communications
Computers and Peripherals	www.ti.com/computers
Consumer Electronics	www.ti.com/consumer-apps
Energy and Lighting	www.ti.com/energy
Industrial	www.ti.com/industrial
Medical	www.ti.com/medical
Security	www.ti.com/security
Space, Avionics and Defense	www.ti.com/space-avionics-defense
Video and Imaging	www.ti.com/video

TI E2E Community

e2e.ti.com