

# BGSA11GN10

Low  $R_{ON}$  Dual Single Pole Single Throw Antenna Tuning Switch

## Data Sheet

Revision 0.3 - 2015-08-04

**Edition 2015-08-04**

**Published by  
Infineon Technologies AG  
81726 Munich, Germany**

**©2012 Infineon Technologies AG  
All Rights Reserved.**

### **Legal Disclaimer**

The information given in this document shall in no event be regarded as a guarantee of conditions or characteristics. With respect to any examples or hints given herein, any typical values stated herein and/or any information regarding the application of the device, Infineon Technologies hereby disclaims any and all warranties and liabilities of any kind, including without limitation, warranties of non-infringement of intellectual property rights of any third party.

### **Information**

For further information on technology, delivery terms and conditions and prices, please contact the nearest Infineon Technologies Office ([www.infineon.com](http://www.infineon.com)).

### **Warnings**

Due to technical requirements, components may contain dangerous substances. For information on the types in question, please contact the nearest Infineon Technologies Office.

Infineon Technologies components may be used in life-support devices or systems only with the express written approval of Infineon Technologies, if a failure of such components can reasonably be expected to cause the failure of that life-support device or system or to affect the safety or effectiveness of that device or system. Life support devices or systems are intended to be implanted in the human body or to support and/or maintain and sustain and/or protect human life. If they fail, it is reasonable to assume that the health of the user or other persons may be endangered.

## Revision History

**Document No.:** BGSA11GN10.pdf

**Revision History:** 0.3

**Previous Version:** 0.2

Page	Subjects (major changes since last revision)
7	updated min frequency

### Trademarks of Infineon Technologies AG

AURIX™, C166™, CanPAK™, CIPOS™, CIPURSE™, CoolGaN™, CoolMOS™, CoolSET™, CoolSiC™, CORECONTROL™, DAVE™, DI-POL™, EasyPIM™, EconoBRIDGE™, EconoDUAL™, EconoPACK™, EconoPIM™, EiceDRIVER™, eupec™, FCOS™, HITFET™, HybridPACK™, ISOFACE™, I<sup>2</sup>RF™, IsoPACK™, MIPAQ™, ModSTACK™, my-d™, NovalithIC™, OmniTune™, OptiMOS™, ORIGA™, OPTIGA™, PROFET™, PRO-SIL™, PRIMARION™, PrimePACK™, RASIC™, ReverSave™, SatRIC™, SIEGET™, SIPMOS™, SOLID FLASH™, SmartLEWIS™, TEMPFET™, thinQ!™, TriCore™, TRENCHSTOP™.

### Other Trademarks

Advance Design System™ (ADS) of Agilent Technologies, AMBA™, ARM™, MULTI-ICE™, PRIMECELL™, REALVIEW™, THUMB™ of ARM Limited, UK. AUTOSAR™ is licensed by AUTOSAR development partnership. Bluetooth™ of Bluetooth SIG Inc. CAT-iq™ of DECT Forum. COLOSSUS™, FirstGPS™ of Trimble Navigation Ltd. EMV™ of EMVCo, LLC (Visa Holdings Inc.). EPCOS™ of Epcos AG. FLEXGO™ of Microsoft Corporation. FlexRay™ is licensed by FlexRay Consortium. HYPERTERMINAL™ of Hilgraeve Incorporated. IEC™ of Commission Electrotechnique Internationale. IrDA™ of Infrared Data Association Corporation. ISO™ of INTERNATIONAL ORGANIZATION FOR STANDARDIZATION. MATLAB™ of MathWorks, Inc. MAXIM™ of Maxim Integrated Products, Inc. MICROTEC™, NUCLEUS™ of Mentor Graphics Corporation. Mifare™ of NXP. MIPI™ of MIPI Alliance, Inc. MIPS™ of MIPS Technologies, Inc., USA. muRata™ of MURATA MANUFACTURING CO., MICROWAVE OFFICE™ (MWO) of Applied Wave Research Inc., OmniVision™ of OmniVision Technologies, Inc. Openwave™ Openwave Systems Inc. RED HAT™ Red Hat, Inc. RFMD™ RF Micro Devices, Inc. SIRIUS™ of Sirius Satellite Radio Inc. SOLARIS™ of Sun Microsystems, Inc. SPANSION™ of Spansion LLC Ltd. Symbian™ of Symbian Software Limited. TAIYO YUDEN™ of Taiyo Yuden Co. TEAKLITE™ of CEVA, Inc. TEKTRONIX™ of Tektronix Inc. TOKO™ of TOKO KABUSHIKI KAISHA TA. UNIX™ of X/Open Company Limited. VERILOG™, PALLADIUM™ of Cadence Design Systems, Inc. VLYNQ™ of Texas Instruments Incorporated. VXWORKS™, WIND RIVER™ of WIND RIVER SYSTEMS, INC. ZETEX™ of Diodes Zetex Limited.

Last Trademarks Update 2012-12-13

## Contents

<b>1</b>	<b>Features</b>	<b>6</b>
<b>2</b>	<b>Product Description</b>	<b>6</b>
<b>3</b>	<b>Maximum Ratings</b>	<b>7</b>
<b>4</b>	<b>Operation Ranges</b>	<b>8</b>
<b>5</b>	<b>Logic Table</b>	<b>8</b>
<b>6</b>	<b>RF small signal parameter</b>	<b>9</b>
<b>7</b>	<b>RF large signal parameter</b>	<b>10</b>
<b>8</b>	<b>Package Outline and Pin Configuration</b>	<b>12</b>
<b>9</b>	<b>Application Examples</b>	<b>16</b>
9.1	Single SPST shunt operation . . . . .	16
9.2	Low $R_{ON}$ SPST shunt operation . . . . .	17
9.3	Dual SPST for RF tuning . . . . .	17

## List of Figures

1	BGSA11GN10 block diagram . . . . .	7
2	Pinout (top view) . . . . .	12
3	Package Dimensions Drawing . . . . .	13
4	Land pattern and stencil mask . . . . .	13
5	Tape drawing . . . . .	14
6	Package marking: Date code digits Y and W are found in Table 13/14 . . . . .	14
7	BGSA11GN10 realizable circuit configurations . . . . .	16
8	BGSA11GN10 single SPST shunt configuration . . . . .	16
9	BGSA11GN10 low $R_{ON}$ SPST shunt configuration . . . . .	17
10	BGSA11GN10 as shunt capacitance tuning device . . . . .	17
11	BGSA11GN10 as shunt inductance tuning device . . . . .	18

## List of Tables

1	Ordering Information . . . . .	6
2	Maximum Ratings, Table I . . . . .	7
3	Maximum Ratings, Table II . . . . .	8
4	Operation Ranges . . . . .	8
5	Logic Table . . . . .	8
6	RF small signal specifications . . . . .	9
7	RF large signal Specifications . . . . .	10
8	Logic Table . . . . .	10
9	Logic Table . . . . .	10
10	Logic Table . . . . .	11
11	Pin description . . . . .	12
12	Mechanical data . . . . .	12
13	Operation Ranges . . . . .	14
14	Operation Ranges . . . . .	15
15	Logic Table . . . . .	18
16	Logic Table . . . . .	18

# BGSA11GN10 Low $R_{ON}$ Dual Single Pole Single Throw Antenna Tuning Switch

## 1 Features

- high-linearity Dual SPST for antenna aperture switching applications
- Ultra-Low  $R_{ON}$  of  $0.79 \Omega$  in ON state for each SPST,  $0.38 \Omega$  using both SPST in parallel
- Ultra-Low  $C_{OFF}$  of  $250 fF$  in OFF state
- High max RF voltage OFF state handling: 36 V peak ( $72 V_{p-p}$ )
- Low harmonic generation
- No power supply blocking required
- Supply voltage: 1.8 to 3.6 V
- Control voltage: 1.35 to 3.3 V (control high)
- Suitable for EDGE / G2K / LTE / WCDMA Applications
- 0.1 to 5.0 GHz coverage
- Small form factor 1.1 mm x 1.5 mm
- $400 \mu m$  pad pitch
- RoHS and WEEE compliant package

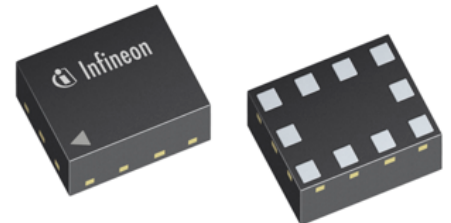

## 2 Product Description

The BGSA11GN10 is a Dual Single Pole Single Throw (SPST) RF antenna aperture switch optimized for low  $R_{on}$  enabling applications up to 5.0 GHz. This single supply chip integrates on-chip CMOS logic driven by a simple, single-pin CMOS or TTL compatible control input signal. The 0.1 dB compression point exceeds the switch maximum input power level, resulting in linear performance at all signal levels. Unlike GaAs technology, the 0.1 dB compression point exceeds the switch maximum input power level, resulting in linear performance at all signal levels and external DC blocking capacitors at the RF ports are only required if DC voltage is applied externally. Due to its very high RF voltage ruggedness it is suited for switching any reactive devices such as inductors and capacitors in RF matching circuits without significant losses in quality factors.

**Table 1: Ordering Information**

Type	Package	Marking	Chip
BGSA11GN10	TSNP10-1	11	BGSA11GN10

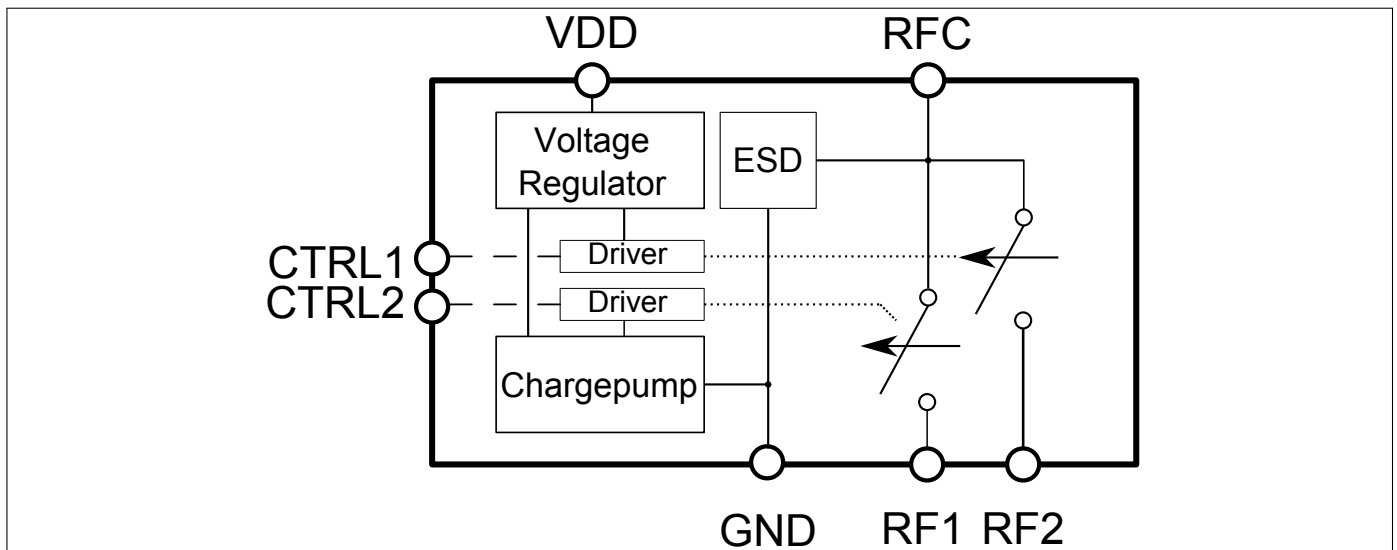
**Figure 1:** BGSA11GN10 block diagram

### 3 Maximum Ratings

**Table 2: Maximum Ratings, Table I** at  $T_A = 25\text{ }^\circ\text{C}$ , unless otherwise specified

Parameter	Symbol	Values			Unit	Note / Test Condition
		Min.	Typ.	Max.		
Frequency Range	$f$	0.1	–	–	GHz	<sup>1)</sup>
Supply voltage <sup>2)</sup>	$V_{DD}$	-0.5	–	3.6	V	–
Storage temperature range	$T_{STG}$	-55	–	150	$^\circ\text{C}$	–
RF input power	$P_{RF\_TRX}$	–	–	39	dBm	25% Duty Cycle
ESD capability, CDM <sup>2)</sup>	$V_{ESDCDM}$	-1.5	–	+1.5	kV	
ESD capability, HBM <sup>4)</sup>	$V_{ESDHBM}$	-1	–	+1	kV	
ESD capability, system level (RFC port) <sup>5)</sup>	$V_{ESDANT}$	-8	–	+8	kV	RFC vs system GND, with 27 nH shunt inductor
Junction temperature	$T_j$	–	–	125	$^\circ\text{C}$	–

<sup>1)</sup> Switch has a low pass response. The DC voltage at RF ports  $V_{RFDC}$  has to be 0V.

<sup>2)</sup> Note: Consider any ripple voltages on top of  $V_{DD}$ . A high RF ripple at the  $V_{DD}$  can exceed the maximum ratings by  $V_{DD} = V_{DC} + V_{Ripple}$ .

<sup>3)</sup> Field-Induced Charged-Device Model JESD22-C101. Simulates charging/discharging events that occur in production equipment and processes. Potential for CDM ESD events occurs whenever there is metal-to-metal contact in manufacturing.

<sup>4)</sup> Human Body Model ANSI/ESDA/JEDEC JS-001-2012 ( $R = 1.5\text{ k}\Omega$ ,  $C = 100\text{ pF}$ ).

<sup>5)</sup> IEC 61000-4-2 ( $R = 330\text{ }\Omega$ ,  $C = 150\text{ pF}$ ), contact discharge.



**Table 3: Maximum Ratings, Table II at  $T_A = 25\text{ °C}$ , unless otherwise specified**

Parameter	Symbol	Values			Unit	Note / Test Condition
		Min.	Typ.	Max.		
Maximum DC-voltage on RF-Ports and RF-Ground	$V_{RFDC}$	0	–	0	V	No DC voltages allowed on RF-Ports
Control Voltage Levels	$V_{CTRL}$	-0.7	–	3.3	V	–

## 4 Operation Ranges

**Table 4: Operation Ranges**

Parameter	Symbol	Values			Unit	Note / Test Condition
		Min.	Typ.	Max.		
Supply voltage	$V_{DD}$	1.8	2.85	3.6	V	–
Supply current <sup>1)</sup>	$I_{DD}$	–	80	150	$\mu A$	–
Control voltage low	$V_{Ctrl,low}$	0		0.45	V	–
Control voltage high	$V_{Ctrl,high}$	1.2	1.8	2.85	V	$V_{Ctrl,high} \ll V_{DD}$
Control current low	$I_{Ctrl,low}$	-1	0	1	$\mu A$	–
Control current high	$I_{Ctrl,high}$	-1	0	1	$\mu A$	$V_{Ctrl,high} \ll V_{DD}$
Ambient temperature	$T_A$	-30	25	85	$^{\circ}C$	–
RF switching time	$t_{sw}$	2	5	7	$\mu s$	–
Startup time	$t_{sw}$		20	30	$\mu s$	–

<sup>1)</sup>  $T_A = -30\text{ °C} - +85\text{ °C}$ ,  $V_{VDD} = 1.8 - 3.6\text{ V}$

## 5 Logic Table

**Table 5: Logic Table**

CTRL 1	CTRL 2	Mode RF1 to RFc	Mode RF2 to RFc
0	0	OFF	OFF
0	1	OFF	ON
1	0	ON	OFF
1	1	ON	ON

<sup>1)</sup>, CTRL1 and CTRL 2 can be connected together to control both switches at once. This enables the use of both SPSTs to reduce Ron by parallel switching.



## 6 RF small signal parameter

**Table 6: RF small signal specifications**

Parameter	Symbol	Values			Unit	Note / Test Condition
		Min.	Typ.	Max.		
Frequency range	f	0.1	–	5.0	GHz	–
Switch ON resistance	$R_{ON}$	0.7	0.79	0.89	$\Omega$	RFx to RFC
Switch OFF capacitance	$C_{OFF}$	–	250	–	fF	RFx to RFC
Parasitic RF shunt capacitance	$C_{SH,PAR}$	–	42	–	fF	RFx to GND, extracted value for 2 GHz
Switch series inductance	$L_{SER}$	–	0.1	–	nH	–
<b>Insertion Loss</b> <sup>(1,2,3)</sup>						
824 - 960 MHz	IL	0.10	0.19	0.28	dB	$V_{DD} = 1.8 - 3.6 V,$ $T_A = -30 \dots +85 \text{ }^\circ\text{C},$ $Z_0 = 50 \Omega,$ RF1 or RF2 switched to RFC
1710 - 1980 MHz		0.18	0.29	0.40	dB	
1981 - 2169 MHz		0.25	0.33	0.40	dB	
2170 - 2690 MHz		0.25	0.35	0.45	dB	
<b>Return Loss</b> <sup>(1,2,3)</sup>						
All Ports @ 824 - 915 MHz	RL	25	28	36	dB	$V_{DD} = 1.8 - 3.6 V,$ $T_A = -30 \dots +85 \text{ }^\circ\text{C},$ $Z_0 = 50 \Omega$
All Ports @ 1710 - 2169 MHz		19	25	30	dB	
All Ports @ 2170 - 2690 MHz		17	23	25	dB	
<b>Isolation RFx to RFC</b> <sup>(1,2,3)</sup>						
824 - 915 MHz	ISO	21	23	30	dB	$V_{DD} = 1.8 - 3.6 V,$ $T_A = -30 \dots +85 \text{ }^\circ\text{C},$ $Z_0 = 50 \Omega$
1710 - 1980 MHz		15	17	20	dB	
1981 - 2169 MHz		14	16	20	dB	
2170 - 2690 MHz		12	14	18	dB	
<b>Isolation RFx to RFx</b> <sup>(1,2,3)</sup>						
824 - 915 MHz	ISO	22	24	31	dB	$V_{DD} = 1.8 - 3.6 V,$ $T_A = -30 \dots +85 \text{ }^\circ\text{C},$ $Z_0 = 50 \Omega$
1710 - 1980 MHz		26	18	21	dB	
1981 - 2169 MHz		15	17	20	dB	
2170 - 2690 MHz		13	14	19	dB	

<sup>1)</sup> Valid for all RF power levels, no compression behavior

<sup>2)</sup> Network analyser input power:  $P_{IN} = -20 \text{ dBm}$

<sup>3)</sup> On application board without any matching components

## 7 RF large signal parameter

**Table 7: RF large signal specifications**

Parameter	Symbol	Values			Unit	Note / Test Condition
		Min.	Typ.	Max.		
RF operating voltage	$V_{RF\_peak}$	–	–	36	V	
<b>Harmonic Generation up to 12.75 GHz<sup>(1,2,3)</sup></b>						
All RF Ports - Second Order Harmonics	$P_{H2}$	–	105	–	dBc	25 dBm, 50Ω, $f_0 = 786$ MHz
All RF Ports - Third Order Harmonics	$P_{H3}$	–	115	–	dBc	25 dBm, 50Ω, $f_0 = 786$ MHz
All RF Ports - Second Order Harmonics	$P_{H2}$	–	98	–	dBc	33 dBm, 50Ω, $f_0 = 824$ MHz
All RF Ports - Third Order Harmonics	$P_{H3}$	–	110	–	dBc	33 dBm, 50Ω, $f_0 = 824$ MHz
All RF Ports	$P_{Hx}$	105	–	–	dBc	25 dBm, 50Ω, CW mode
<b>Intermodulation Distortion IMD2<sup>(1,2,3)</sup></b>						
IIP2, low	IIP2,l	–	110	–	dBm	IIP2 conditions table 8
IIP2, high	IIP2,h	–	120	–	dBm	
<b>Intermodulation Distortion IMD3<sup>(1,2,3)</sup></b>						
IIP3	IIP3	–	75	–	dBm	IIP3 conditions table 9
<b>SV LTE Intermodulation<sup>(1,2,3)</sup></b>						
IIP3,SVLTE	IIP3,SV	–	75	–	dBm	SV-LTE conditions table 10

<sup>1</sup>)Terminating Port Impedance:  $Z_0 = 50 \Omega$  <sup>2</sup>)Supply Voltage:  $V_{DD} = 1.8 - 3.6 V$  <sup>3</sup>)On application board without any matching components

**Table 8: IIP2 conditions table**

Band	In-Band Frequency [MHz]	Blocker Frequency 1 [MHz]	Blocker Power 1 [dBm]	Blocker Frequency 2 [MHz]	Blocker Power 2 [dBm]
Band 1 Low	2140	1950	20	190	-15
Band 1 High	2140	1950	20	4090	-15
Band 5 Low	881.5	836.5	20	45	-15
Band 5 High	881.5	836.5	20	1718	-15

**Table 9: IIP3 conditions table**

Band	In-Band Frequency [MHz]	Blocker Frequency 1 [MHz]	Blocker Power 1 [dBm]	Blocker Frequency 2 [MHz]	Blocker Power 2 [dBm]
Band 1	2140	1950	20	1760	-15
Band 5	881.5	836.5	20	791.5	-15

**Table 10: SV-LTE conditions table**

Band	In-Band Frequency [MHz]	Blocker Frequency 1 [MHz]	Blocker Power 1 [dBm]	Blocker Frequency 2 [MHz]	Blocker Power 2 [dBm]
Band 5	872	827	23	872	14
Band 13	747	786	23	747	14
Band 20	878	833	23	2544	14

## 8 Package Outline and Pin Configuration

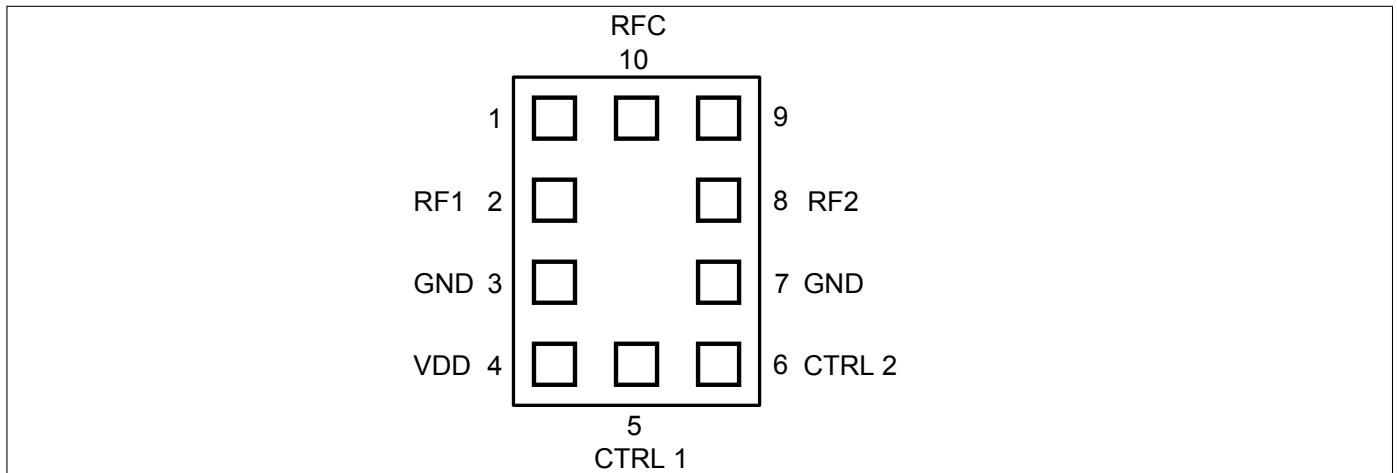

Figure 2: Pinout (top view)

Table 11: Pin Description

Pin No.	Name	Pin Type	Buffer Type	Function
1	N.C.	N.C.		Not connected
2	RF1	I/O		RF1
3	GND	GND		Ground
4	VDD	PWR		Supply voltage
5	CTRL 1	I		Control Pin
6	CTRL 2	I		Control Pin
7	GND	GND		Ground
8	RF2	I/O		RF2
9	N.C.	N.C.		Not connected
10	RFC	I/O		Common RF

Table 12: Mechanical Data

Parameter	Symbol	Value	Unit
X-Dimension	<i>X</i>	1.1 ± 0.05	mm
Y-Dimension	<i>Y</i>	1.5 ± 0.05	mm
Size	<i>Size</i>	1.65	mm <sup>2</sup>
Height	<i>H</i>	0.375	mm

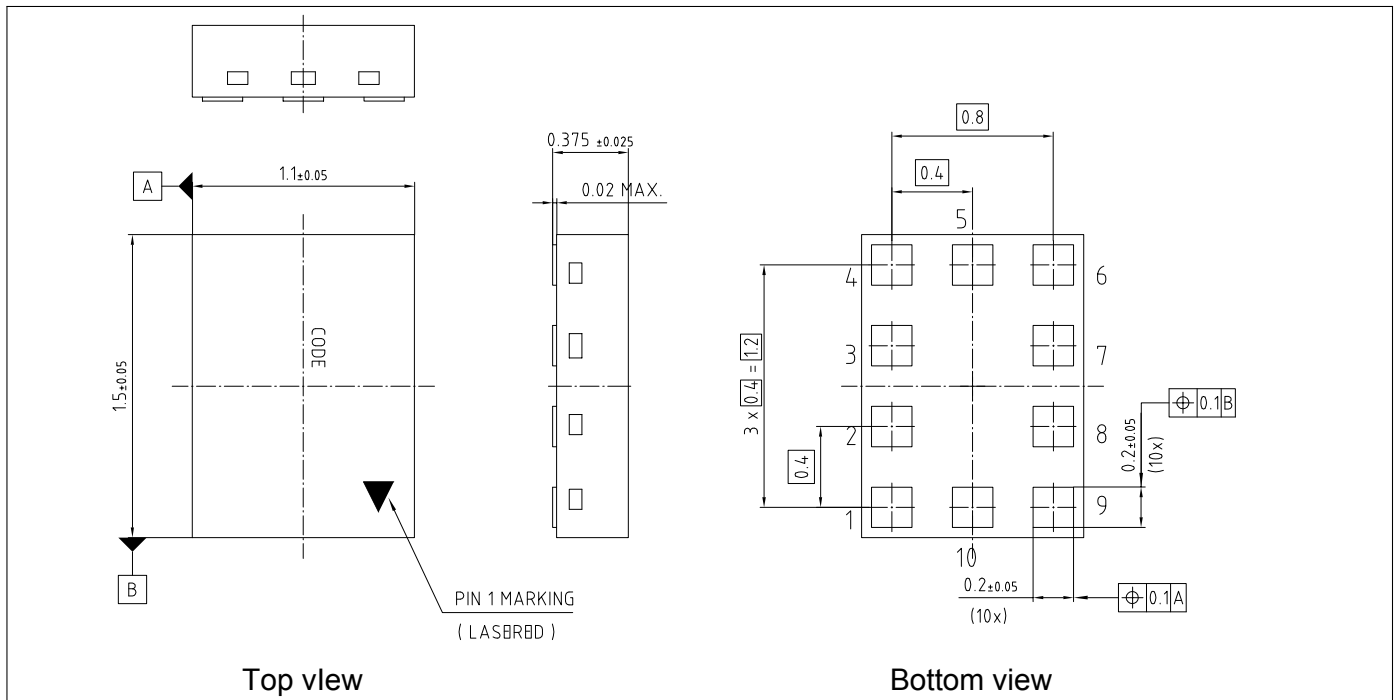

Figure 3: Package Dimensions Drawing

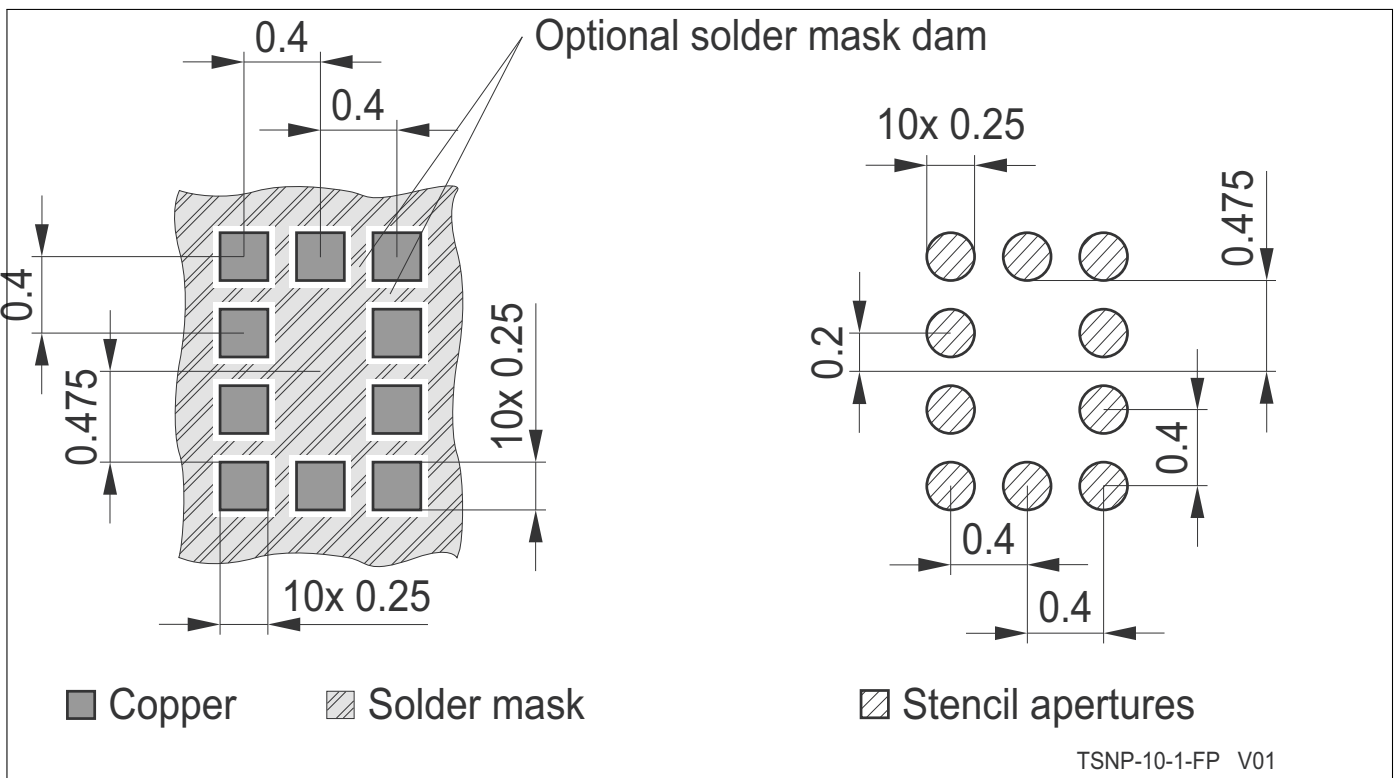

Figure 4: Land pattern and stencil mask

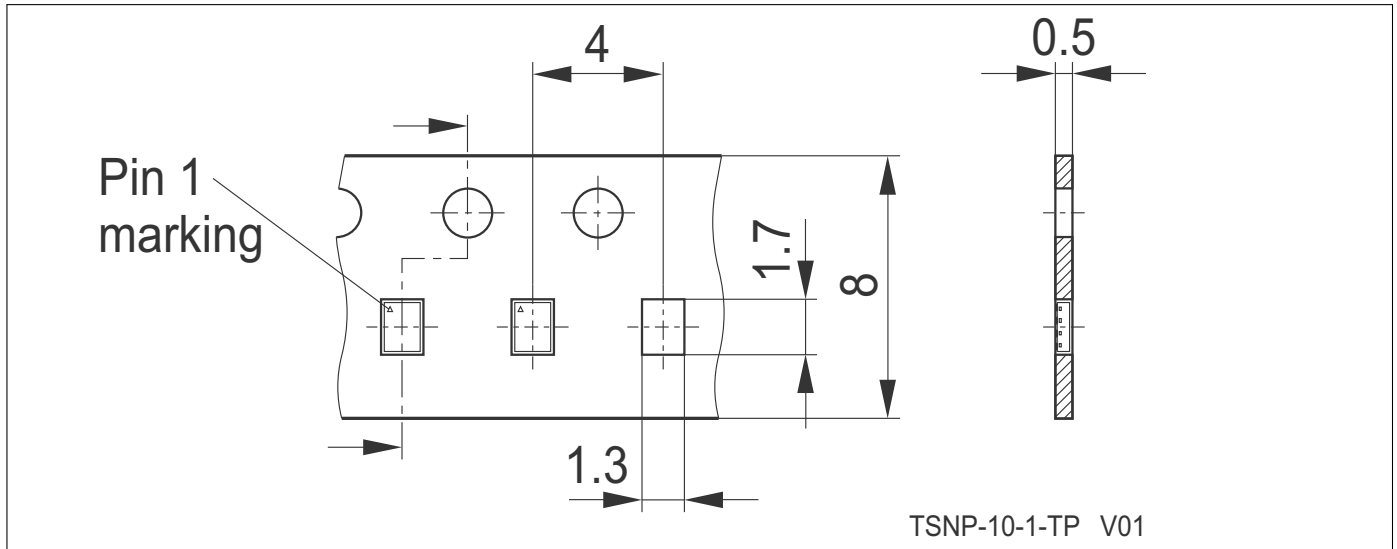

Figure 5: Tape drawing

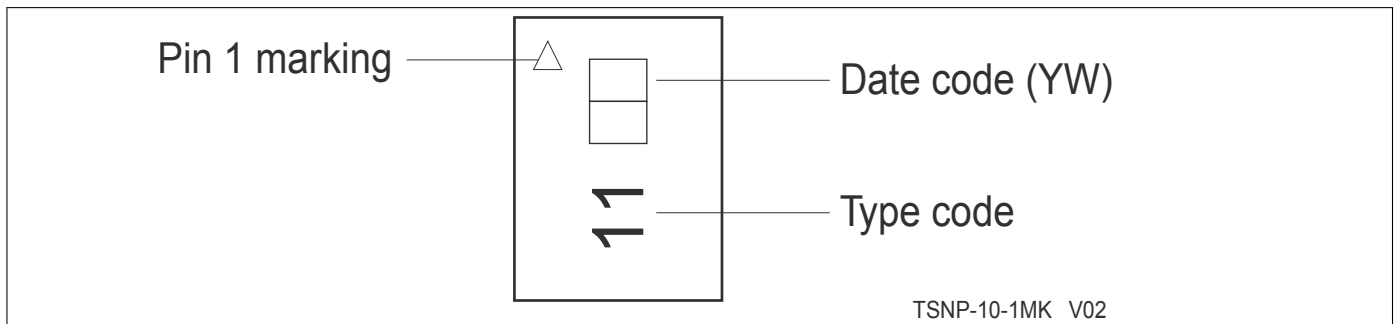

Figure 6: Package marking: Date code digits Y and W are found in Table 13/14

Table 13: Year date code marking - digit "Y"

Year	"Y"	Year	"Y"	Year	"Y"
2000	0	2010	0	2020	0
2001	1	2011	1	2021	1
2002	2	2012	2	2022	2
2003	3	2013	3	2023	3
2004	4	2014	4	2024	4
2005	5	2015	5	2025	5
2006	6	2016	6	2026	6
2007	7	2017	7	2027	7
2008	8	2018	8	2028	8
2009	9	2019	9	2029	9

**Table 14: Week date code marking - digit "W"**

Week	"W"	Week	"W"	Week	"W"	Week	"W"	Week	"W"
1	A	12	N	23	4	34	h	45	v
2	B	13	P	24	5	35	j	46	x
3	C	14	Q	25	6	36	k	47	y
4	D	15	R	26	7	37	l	48	z
5	E	16	S	27	a	38	n	49	8
6	F	17	T	28	b	39	p	50	9
7	G	18	U	29	c	40	q	51	2
8	H	19	V	30	d	41	r	52	3
9	J	20	W	31	e	42	s		
10	K	21	Y	32	f	43	t		
11	L	22	Z	33	g	44	u		



## 9 Application Examples

The BGSA11GN10 is a dual single pole single throw (SPST) RF switch in a 1.05 mm x 1.55 mm TSNP-10-1 package. Both SPST can be controlled individually by the control placed next to each other. This solution allows the use of the device for several applications shown in Fig. 7:

- Low  $R_{ON} = 0.79\Omega$  SPST (a) or ultra low  $R_{ON} = 0.38\Omega$  SPST (b)
- Tuning with 2 reactive devices such as capacitors or inductors. (c)
- Combinations of above.

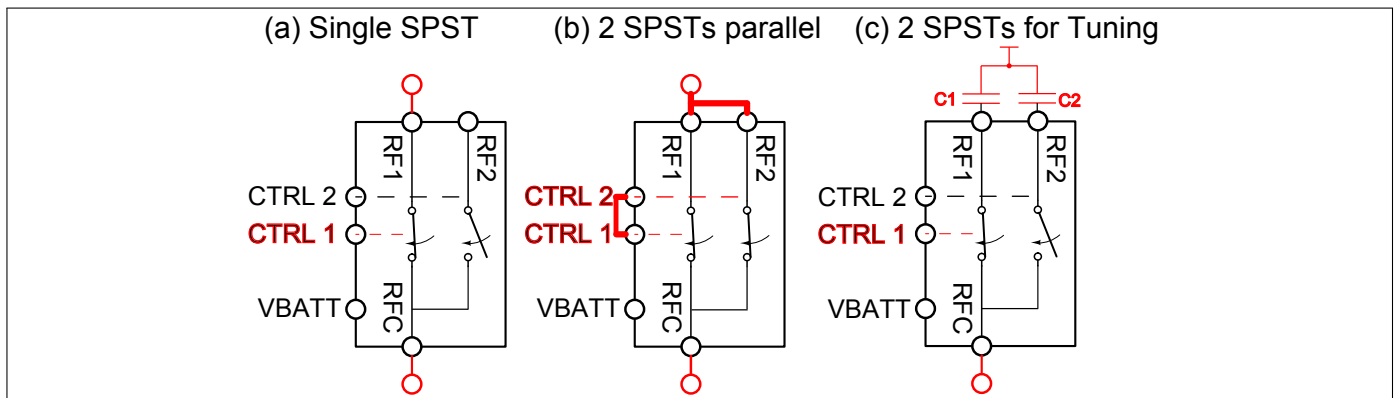

**Figure 7:** BGSA11GN10 realizable circuit configurations

### 9.1 Single SPST shunt operation

The configuration (a) is used to obtain an  $R_{ON} = 0.79\Omega$  and  $C_{OFF} = 250fF$ . It can be used for series and shunt configurations. Note, that for single SPST shunt configuration, it is better to connect RFC to GND to avoid additional capacitance contribution of the unused part RF2 to GND as shown in Fig. 8. For simplicity, connecting the unused RF and Control Pin can be connected to ground.

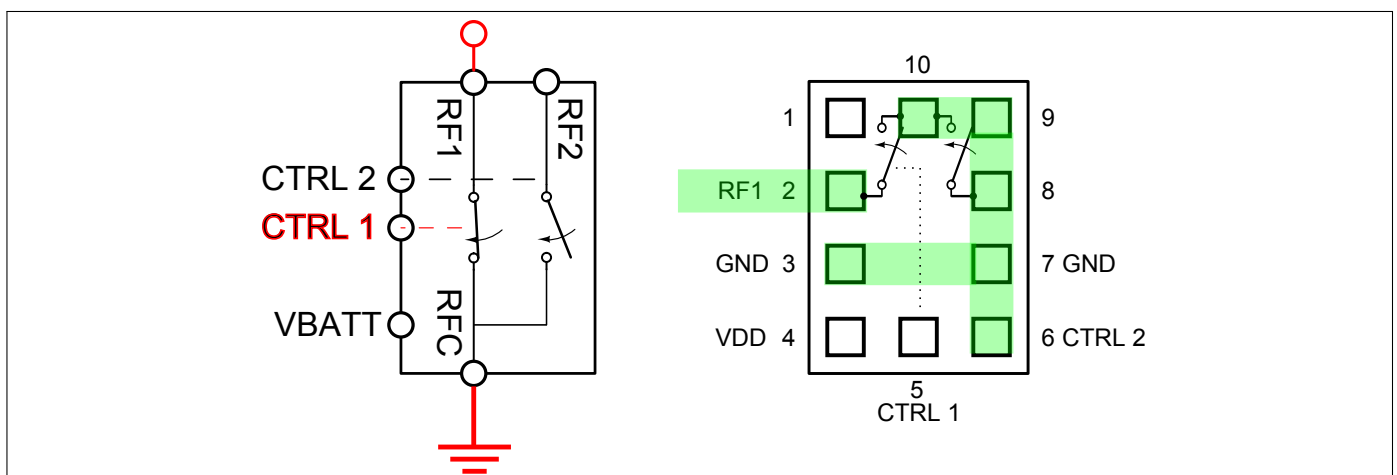

**Figure 8:** BGSA11GN10 single SPST shunt configuration

**9.2 Low  $R_{ON}$  SPST shunt operation**

For lowest possible  $R_{ON} = 0.38\Omega$  operation, it is required to connect the logic inputs CTRL 1 with CTRL 2 together and same for RF1 and RF2 as shown in Fig. 9

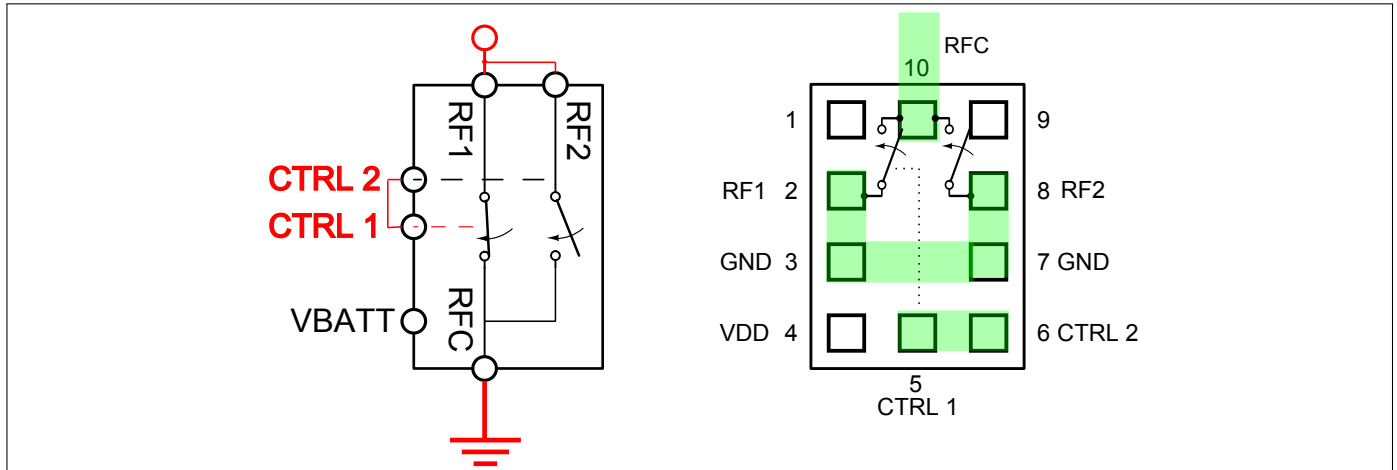

**Figure 9:** BGSA11GN10 low  $R_{ON}$  SPST shunt configuration

**9.3 Dual SPST for RF tuning**

The dual SPST can also be used for tuning applications, for example to tune capacitance or inductance. Fig. 10 shows as example a tunable capacitance with 4 steps by using 2 external MLCC capacitors. Note that the RF voltage should not exceed the specified 36 V over the switch device and also not for the used capacitor.

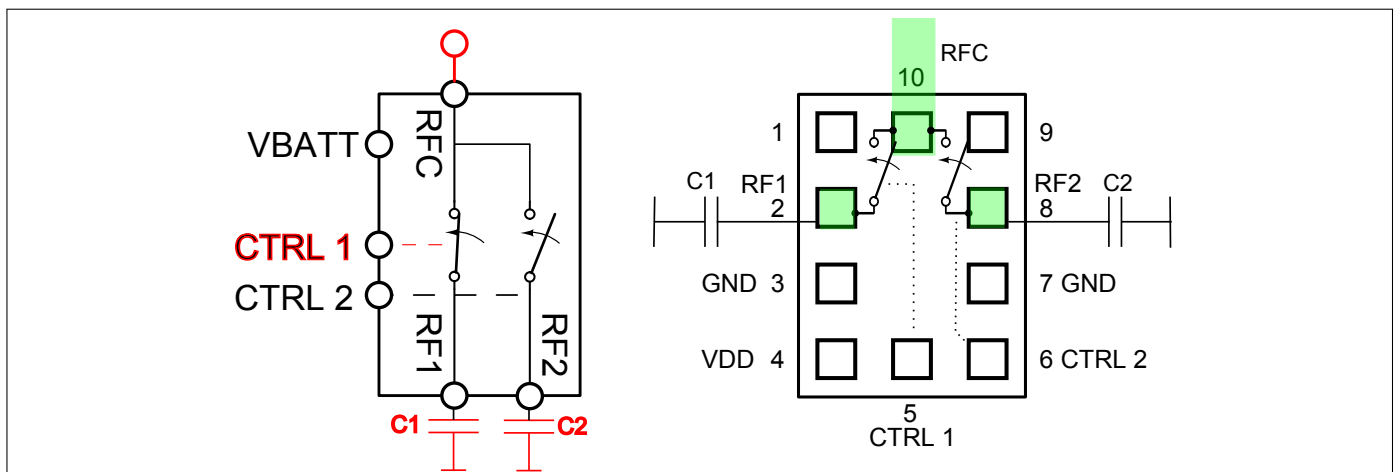

**Figure 10:** BGSA11GN10 as shunt capacitance tuning device

For example, resulting capacitances using C1 and C2 can be controlled as shown in table 15. Resulting Q factors can be calculated using the  $R_{ON}$  values using the equation  $Q = \frac{1}{\omega R_{ON} C}$  with  $\omega = 2\pi f$ . Same function can be realized also with inductors (Fig. 11) with  $Q = \frac{\omega L}{R_{ON}}$  in table 16.

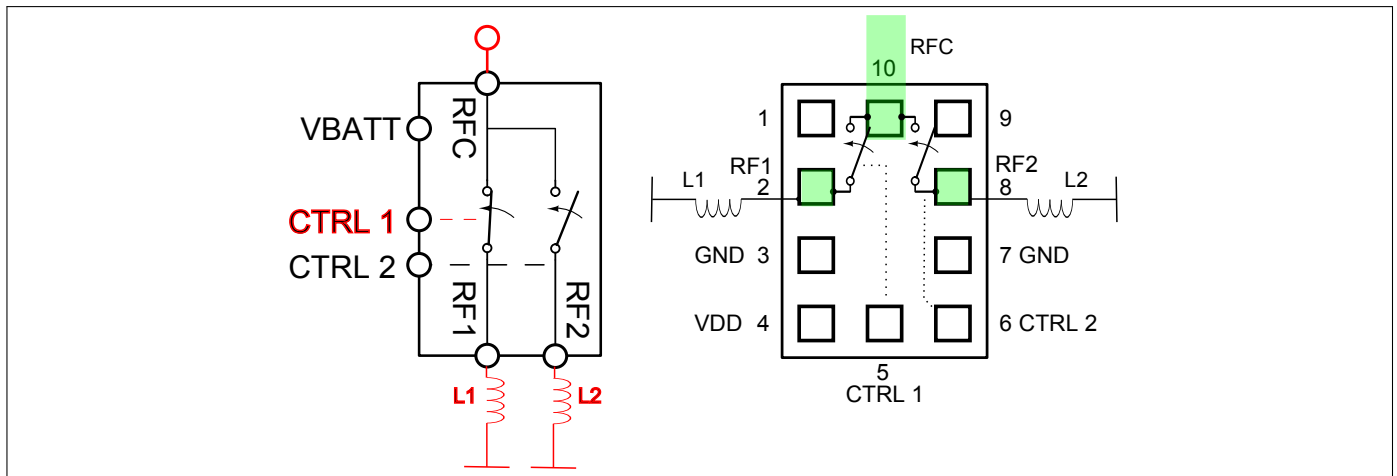
**Figure 11:** BGSA11GN10 as shunt inductance tuning device

**Table 15: Logic Table**

CTRL 1	CTRL 2	Mode RF1 to RFc	Mode RF2 to RFc	Capacitance	$R_{ON}$
0	0	OFF	OFF	500 fF	500 k $\Omega$
0	1	OFF	ON	250 fF + C2	0.79 $\Omega$
1	0	ON	OFF	250 fF + C1	0.79 $\Omega$
1	1	ON	ON	C1 + C2	0.38 $\Omega$

**Table 16: Logic Table**

CTRL 1	CTRL 2	Mode RF1 to RFc	Mode RF2 to RFc	Inductance	$R_{ON}$
0	0	OFF	OFF	-	500 k $\Omega$
0	1	OFF	ON	L2	0.79 $\Omega$
1	0	ON	OFF	L1	0.79 $\Omega$
1	1	ON	ON	L1    L2	0.38 $\Omega$

[www.infineon.com](http://www.infineon.com)

Published by Infineon Technologies AG