

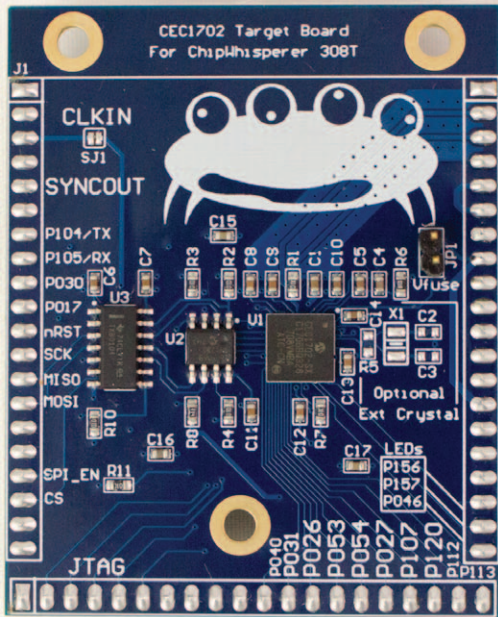

# CEC1702 UFO Target



The CEC1702 has the unique CEC1702 chip from Microchip which features a Cortex M4F. This device contains extensive hardware cryptographic accelerators, including public key accelerators.

This device requires at minimum a JTAG programmer, but as it does not contain internal flash you also may need a SPI flash programmer if you wish to program the on-board SPI flash memory.

The baseboard is designed to allow various measurements to be performed, including on both the device during regular operation as well as during the loading process.

**CW308 UFO Baseboard REQUIRED for use!**  
**Programmer REQUIRED for use!**

## Product Highlights

Microchip CEC1702 target device.

SPI Flash chip includes bidirectional buffer to allow (a) programming of on-board SPI flash chip with external programmer, (b) sniffing SPI traffic without loading data lines, and (c) triggering on SPI traffic.

Example implementation of firmware projects that run on this device, including use of cryptographic AES accelerator.

Documentation on some of the unique features of the CEC1702 including the odd fuse requirements can be found on the wiki.

It is required to use a JTAG debugger for this device to simplify development and debug - we highly recommend an Arm JTAG programmer such as a Segger J-Link. If you wish to program the on-board SPI flash memory (the device has no FLASH memory itself) a SPI programmer is required. See wiki for full details and pinout.

Full design files are available under an open-source license.

## Ordering Summary

NAE-CW308T-CEC1702 Microchip CEC1702 UFO Target Board.

## Product Links

- Full Documentation <https://wiki.newae.com/CW308T-CEC1702>
- Hardware Design <https://github.com/newaetech/chipwhisperer-target-cw308t>
- Firmware Example <https://github.com/newaetech/chipwhisperer/tree/develop/hardware/victims/firmware/>



### Pin Connections

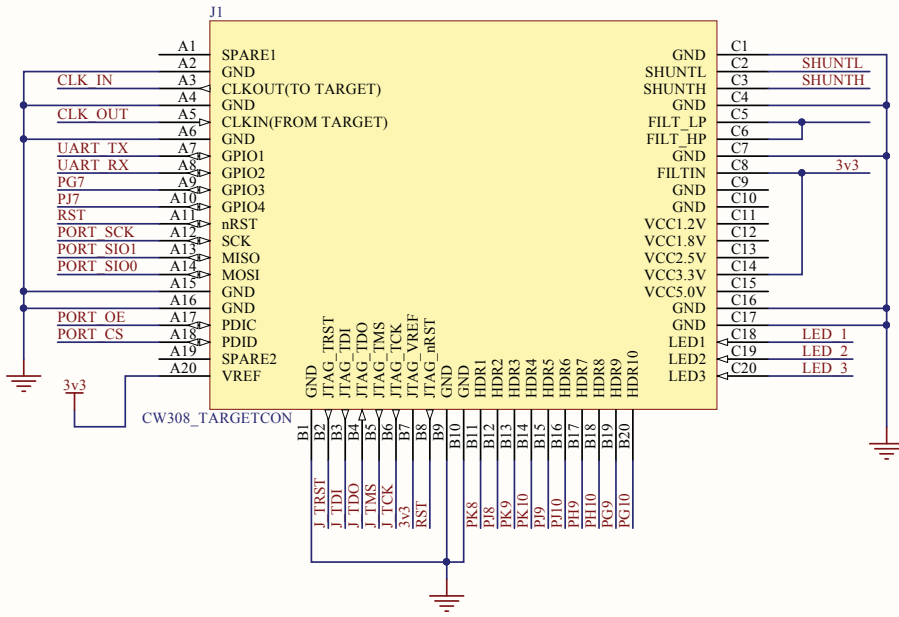

### Decoupling Capacitors

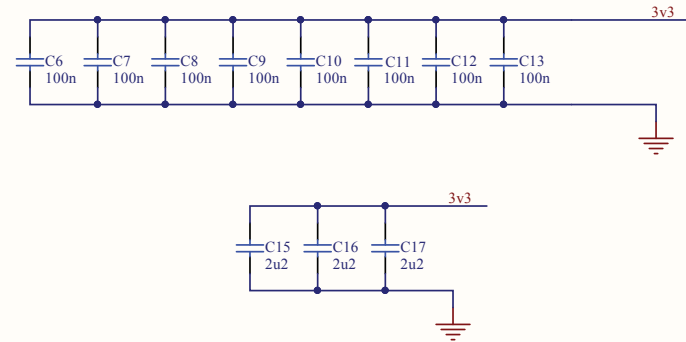

Title: <b>CEC1702 Target Pin Connections</b>		Approved: YES	
Rev: 01	Project: CEC1702 Target	License: GPL	
Date: 30/05/2019	Time: 2:47:06 PM	Sheet2 of 2	Copyright © NewAE Technology Inc.   NewAE.com
File: CW308T_CEC1702_UFO.SchDoc			

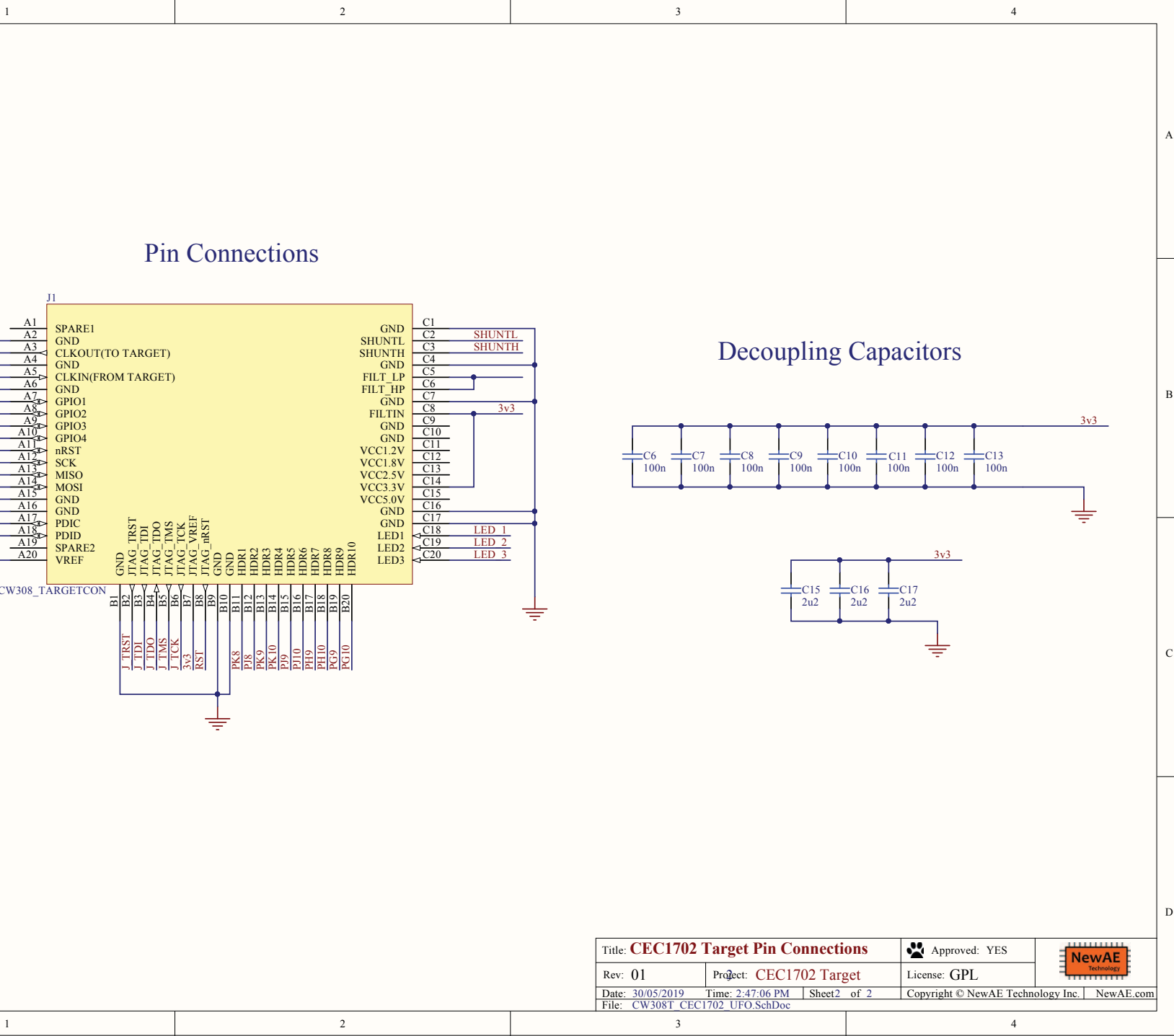

## Disclaimers

All content is Copyright NewAE Technology Inc., 2018. ChipWhisperer is a trademark of NewAE Technology Inc., registered in the United States of America and Europe. ChipSHOUTER is a trademark of NewAE Technology Inc., registered in Europe. Trademarks are claimed in all jurisdictions and may be registered in other states than specified here.

NewAE Technology makes no representations or warranties with respect to the accuracy or completeness of the contents of this document and reserves the right to make changes to specifications and product descriptions at any time without notice. NewAE Technology does not make any commitment to update the information contained herein. NewAE Technology products are not intended, authorized, or warranted for use as components in applications intended to support or sustain life. NewAE Technology products are designed solely for teaching purposes.

All other product names and trademarks are the property of their respective owners, which are in no way associated or affiliated with NewAE Technology Inc. Use of these names does not imply any co-operation or endorsement.