

THIS DRAWING IS UNPUBLISHED. RELEASED FOR PUBLICATION 20
 © COPYRIGHT 20 BY TYCO ELECTRONICS CORPORATION. ALL RIGHTS RESERVED.

LOC	DIST	REVISIONS					
CE	00	P	LTR	DESCRIPTION	DATE	DWN	APVD
		H		REV PER ECR-06-008849	19MAY2006	BB	DK
		J		REVISE PER ECR-09-000232	09JAN2009	BB	DK

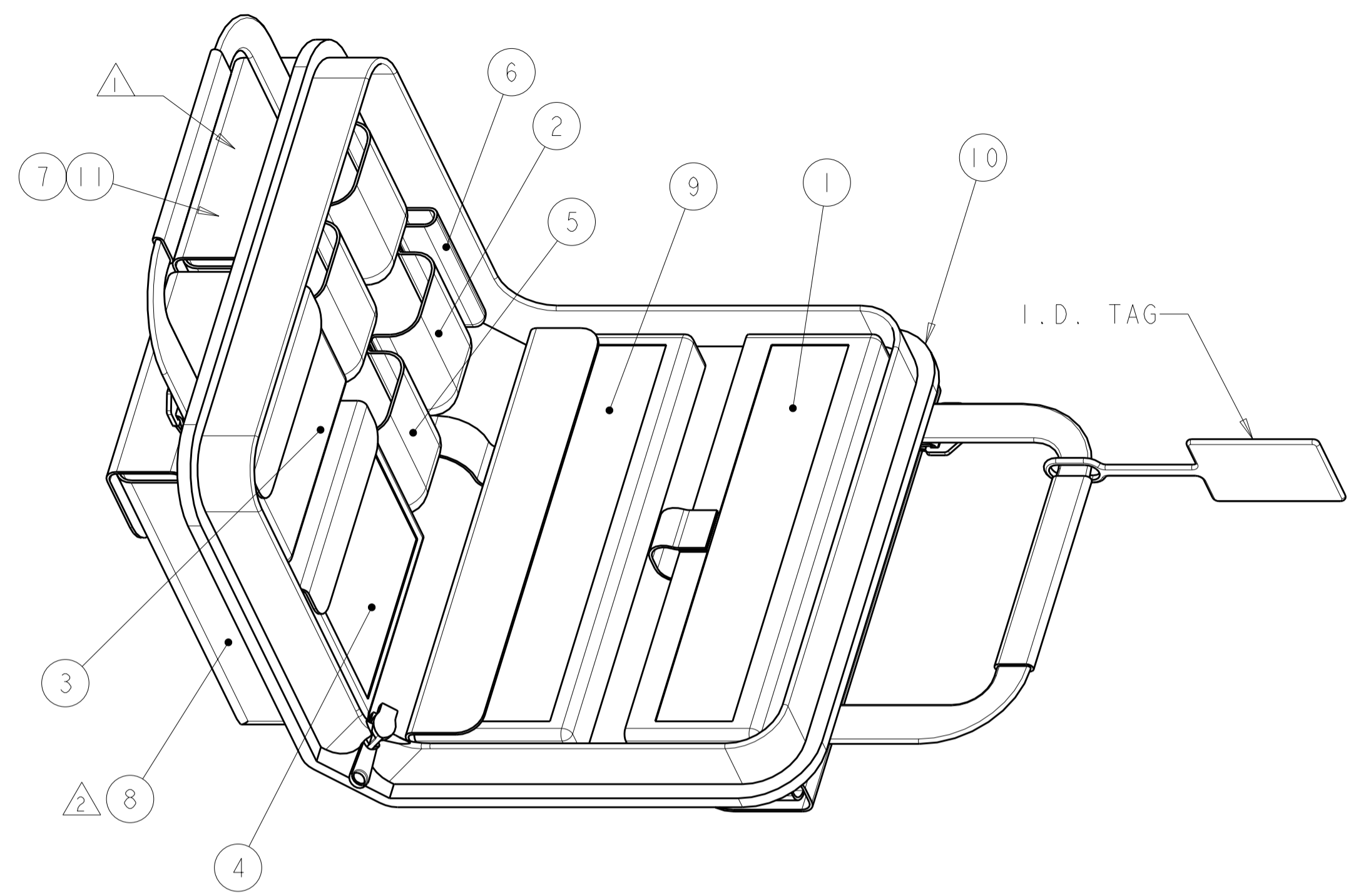

△ INSTRUCTION SHEETS AND MANUFACTURER'S INSTRUCTION SHEETS.
 △ OPTIONAL SHOULDER STRAP.

1	1	2064710-1	FIBER OPTICS CLEANING & INSPECTION GUIDE	11
1	1	1278540-1	PREMIUM SOFTCASE	10
1	-	1754767-1	200x MICROSCOPE	9
1	1	1871696-1	FIBER CLEAVER, SLIDE CUTTER	8
1	1	1374503-1	CD ROM, TERMINATION TRAINING	7
2	2	1278422-1	OPEN END WRENCH, 1/4	6
1	1	1278637-1	KEVLAR SHEARS	5
1	1	492703-1	CABLE CLAMP, LightCrimp Plus ST	4
14	14	501857-2	ALCOHOL WIPES	3
1	1	1754708-1	FIBER STRIP TOOL, COMB.	2
1	1	492623-1	HAND TOOL WITH DIESET, ST	1
-2	-1	PART NUMBER	DESCRIPTION	ITEM NO.

<small>THIS DRAWING IS A CONTROLLED DOCUMENT FOR TYCO ELECTRONICS CORPORATION. IT IS SUBJECT TO CHANGE AND THE CONTROLLING ENGINEERING ORGANIZATION SHOULD BE CONTACTED FOR THE LATEST REVISION.</small>		DWN B. BRIGGS 19MAY2006 CHK D. KIRSCH 19MAY2006 APVD S. BUCHTER 19MAY2006	Tyco Electronics Harrisburg, PA 17105-3608
DIMENSIONS: mm 	TOLERANCES UNLESS OTHERWISE SPECIFIED: 0 PLC ± 1 PLC ± 2 PLC ± 3 PLC ± 4 PLC ± ANGLES ± FINISH	PRODUCT SPEC APPLICATION SPEC WEIGHT	NAME TERMINATION KIT, LightCrimp Plus, ST STYLE SIZE CAGE CODE DRAWING NO RESTRICTED TO A200779 C-492697 -
MATERIAL		CUSTOMER DRAWING	SCALE NTS SHEET 1 OF 1 REV J