

10135262 - 10X LF

LEAD-FREE DESIGNATION ONLY WITH APPLICABLE PLATING CODES

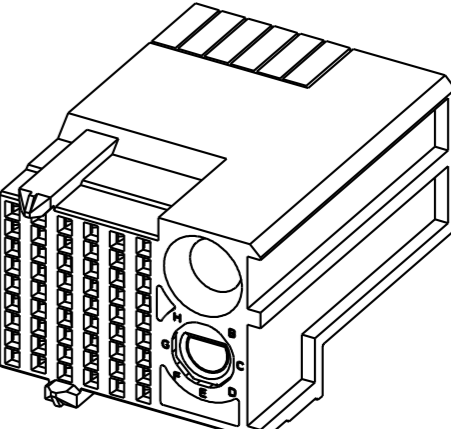
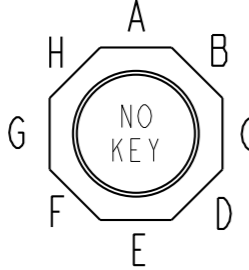
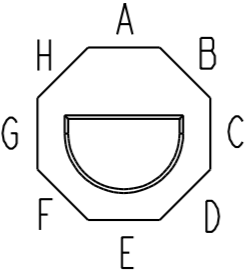
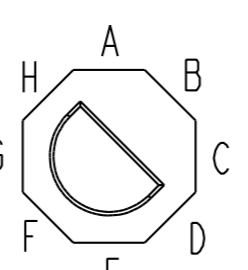
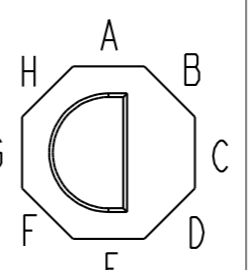
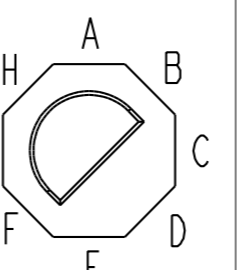
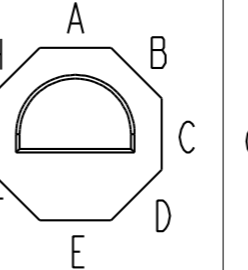
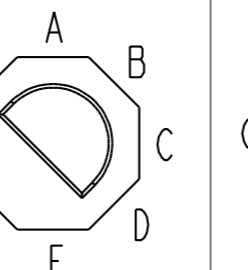
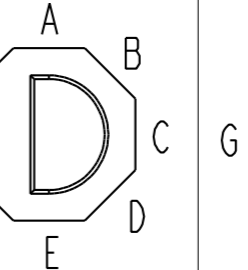
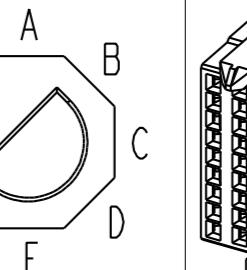
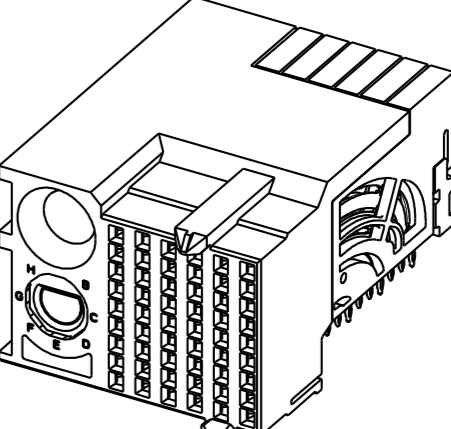
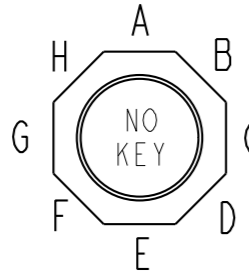
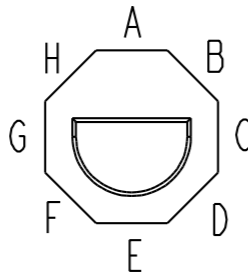
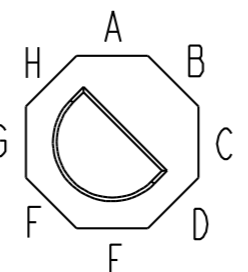
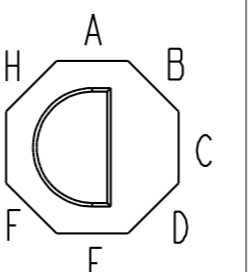
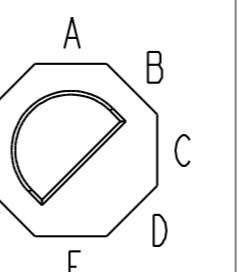
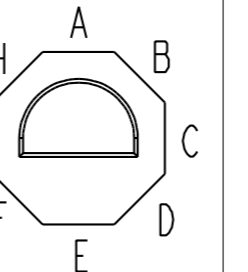
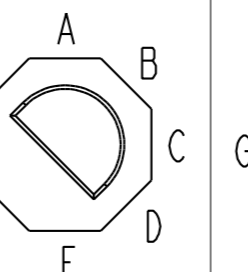
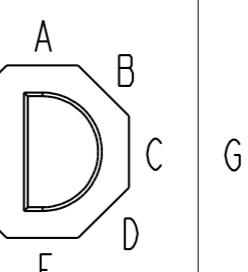
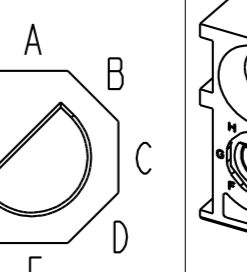

SEE NOTE 2

LETTER DESIGNATION REPRESENTED IN DASH NUMBER

MODULE DESCRIPTION	LETTER DESIGNATION REPRESENTED IN DASH NUMBER										BASE MODULE
RIGHT POLARIZING GUIDANCE MODULE (SEE SHEET 3)	N	J (NO KEY)	A	B	C	D	E	F	G	H	
	NO KEY NO GUIDE PIN										
LEFT POLARIZING GUIDANCE MODULE (SEE SHEET 2)	Z	Y (NO KEY)	P	Q	R	S	T	U	V	W	
	NO KEY NO GUIDE PIN										

Amphenol FCI

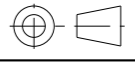
© 2016 AFCI

spec ref	---	dr	Jeny Ren	2015/05/20	projection	MM	size	A2	scale	8:1	
tolerance std	ASME Y14.5M	eng	Terry Luo	2019/01/31		←	ecn no	-	rel level	Released	
TOLERANCES UNLESS OTHERWISE SPECIFIED		chr	Stone Li	2019/01/31							product family
surface	- ✓	linear	0.X	±.3		title	AIRMAX VSE R.A. RECEPTACLE	drg no	10135262	rev	A
			0.XX	±.15							
			0.XXX	±.050							
		angular	0°	±°	cat. no.	-	Product - Customer Drw	sheet 1 of 4			

PDS: Rev :A

STATUS:Released

Printed: Jan 31, 2019

LEFT POLARIZATION WITH GUIDE

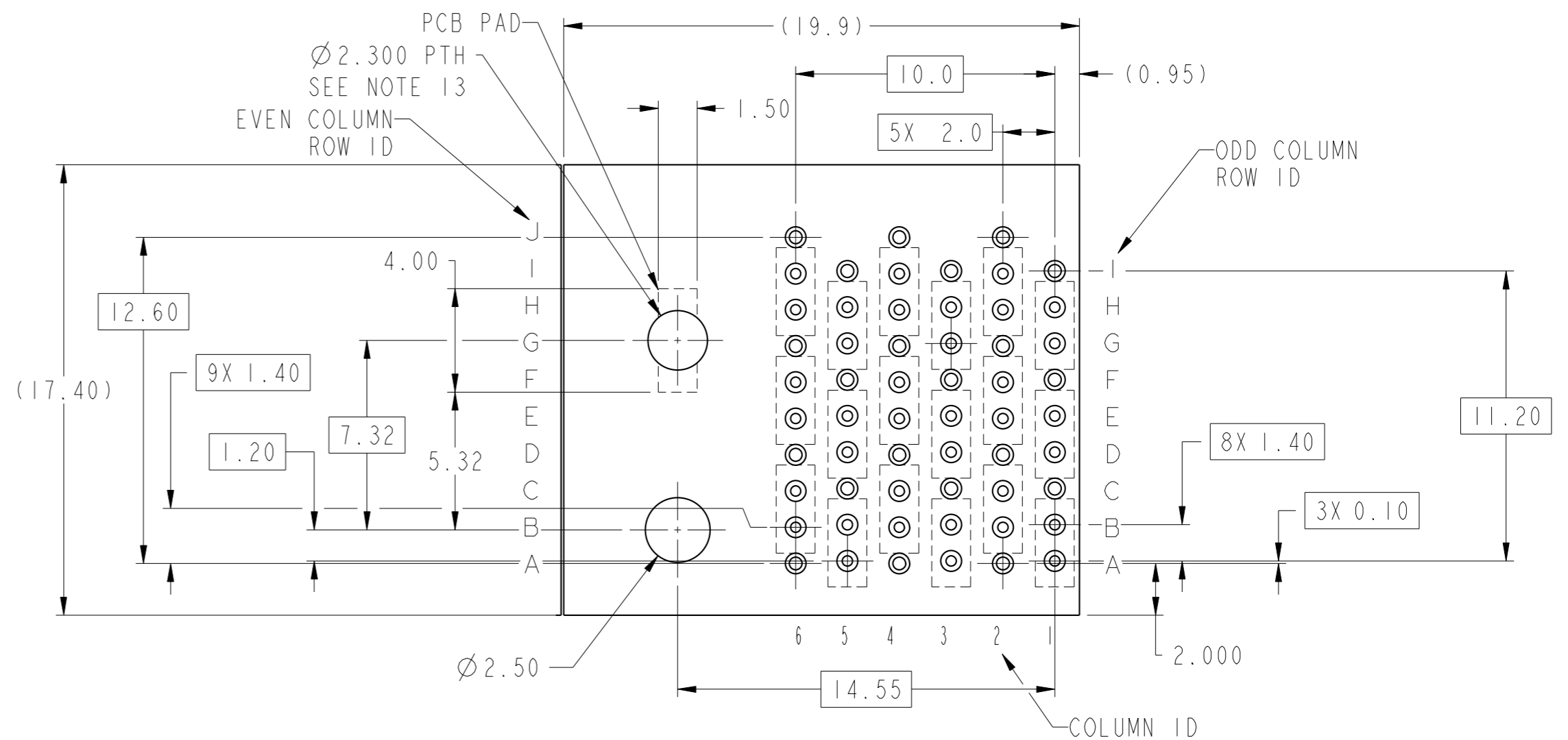
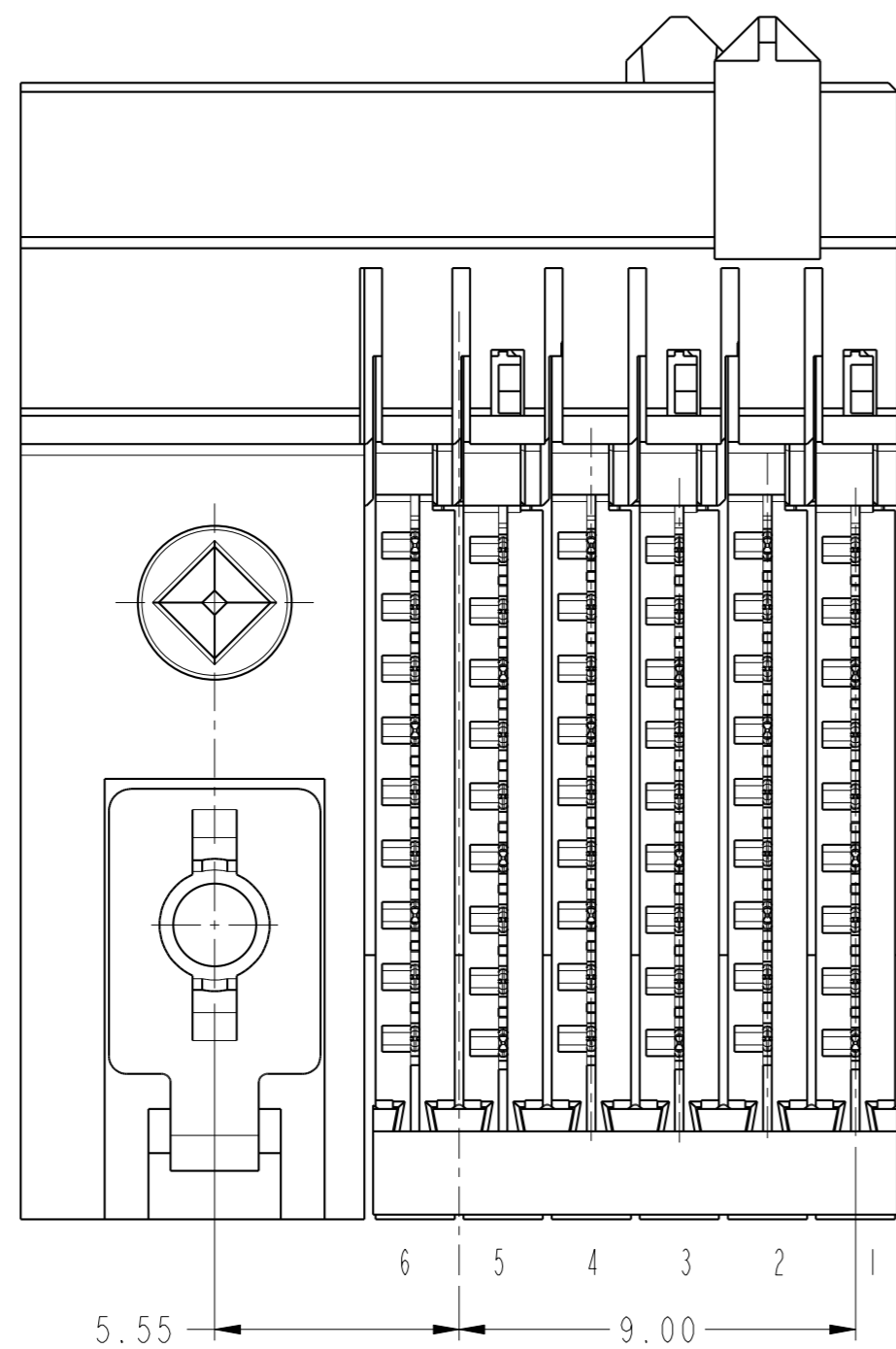
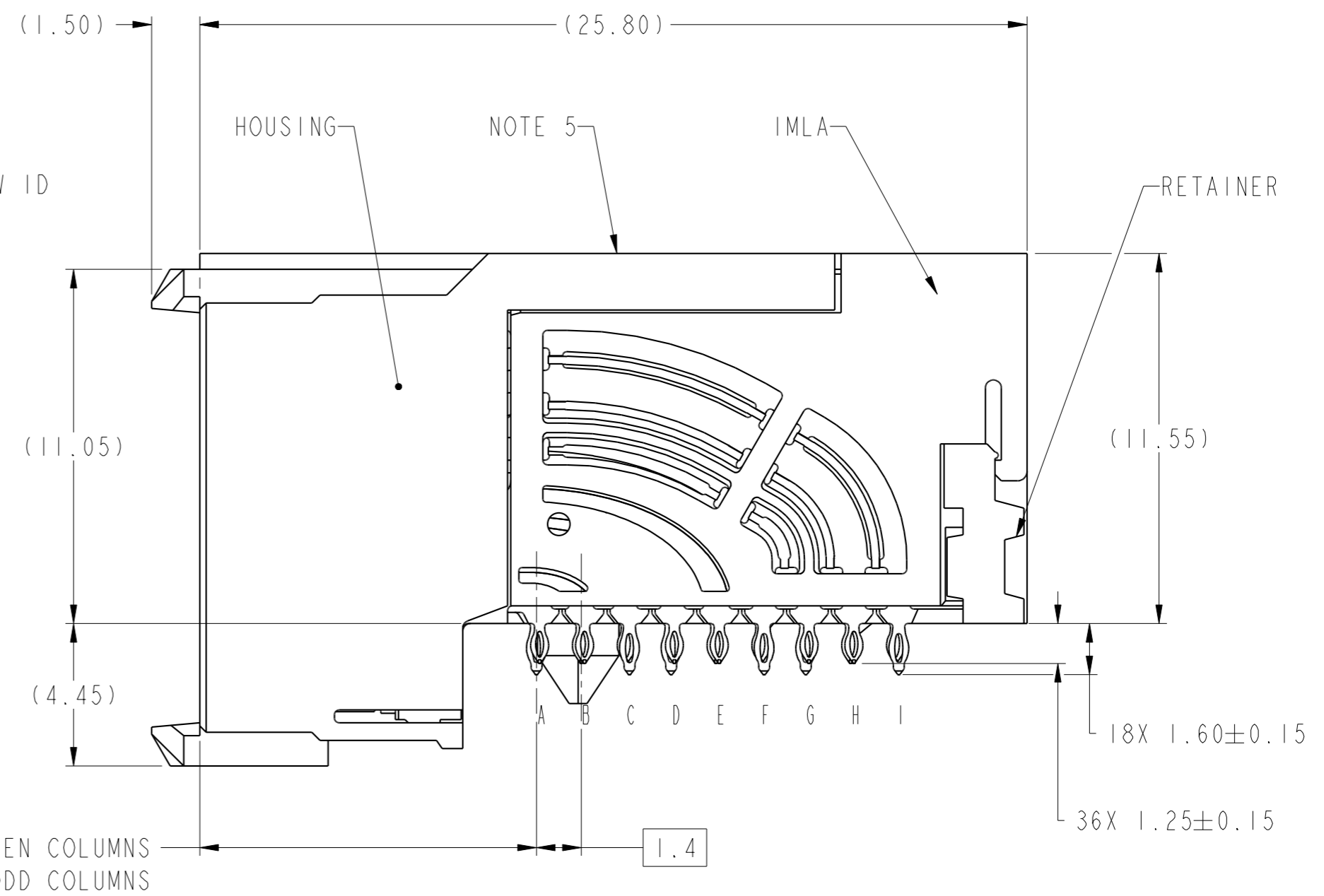
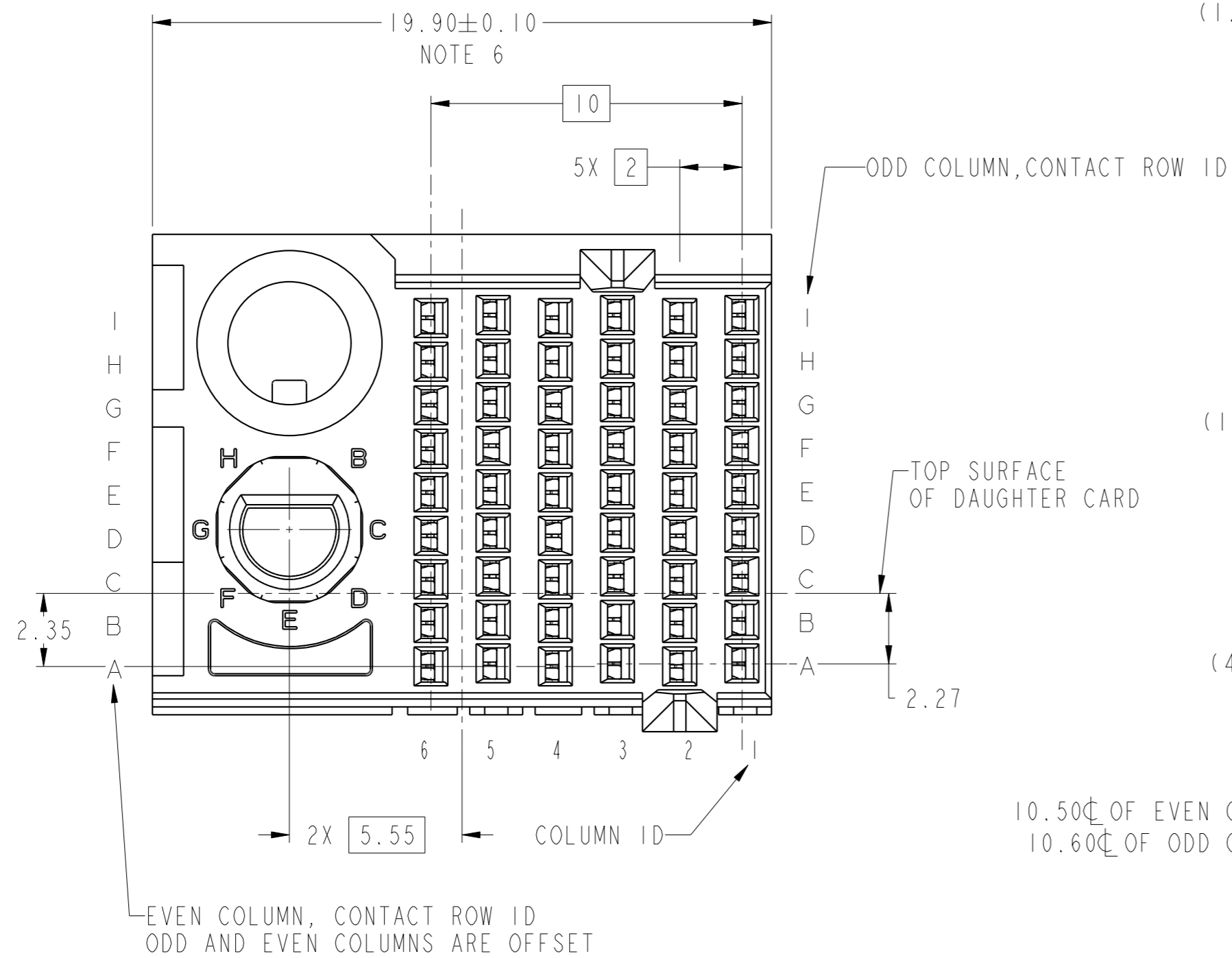

RECOMMENDED PCB LAYOUT

spec ref	---	dr	Jeny Ren	2015/05/20	projection	MM	size	A2	scale	6:1
tolerance std	ASME Y14.5M	eng	Terry Luo	2019/01/31			ecn no	-	rel level	Released
TOLERANCES UNLESS OTHERWISE SPECIFIED		chr	Stone Li	2019/01/31						
surface	linear	0.X	±.3		product family	AirMax VS2	title	AIRMAX VSE R.A. RECEPTACLE	dwg no	10135262
		0.XX	±.15		ASS'Y, 3 PAIR, 54 POS, 6 IMLA, 20MM, W/GUIDE/KEY	rev	A			
	angular	0°	±°		cat. no.	Product - Customer Drw	sheet 2 of 4			

PDS: Rev :A

STATUS:Released

Printed: Jan 31, 2019

Amphenol FCI

© 2016 AFCI

RIGHT POLARIZATION WITH GUIDE

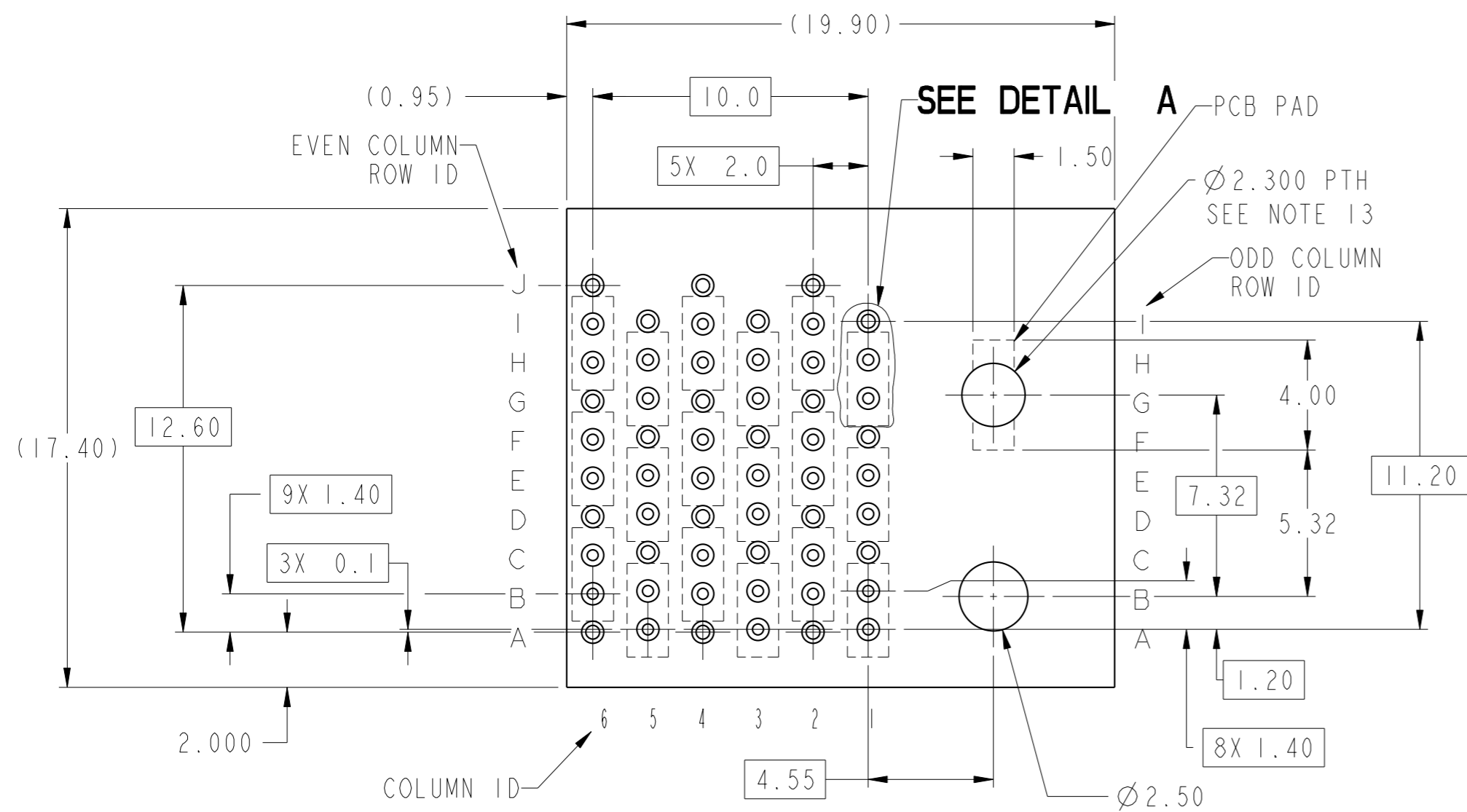
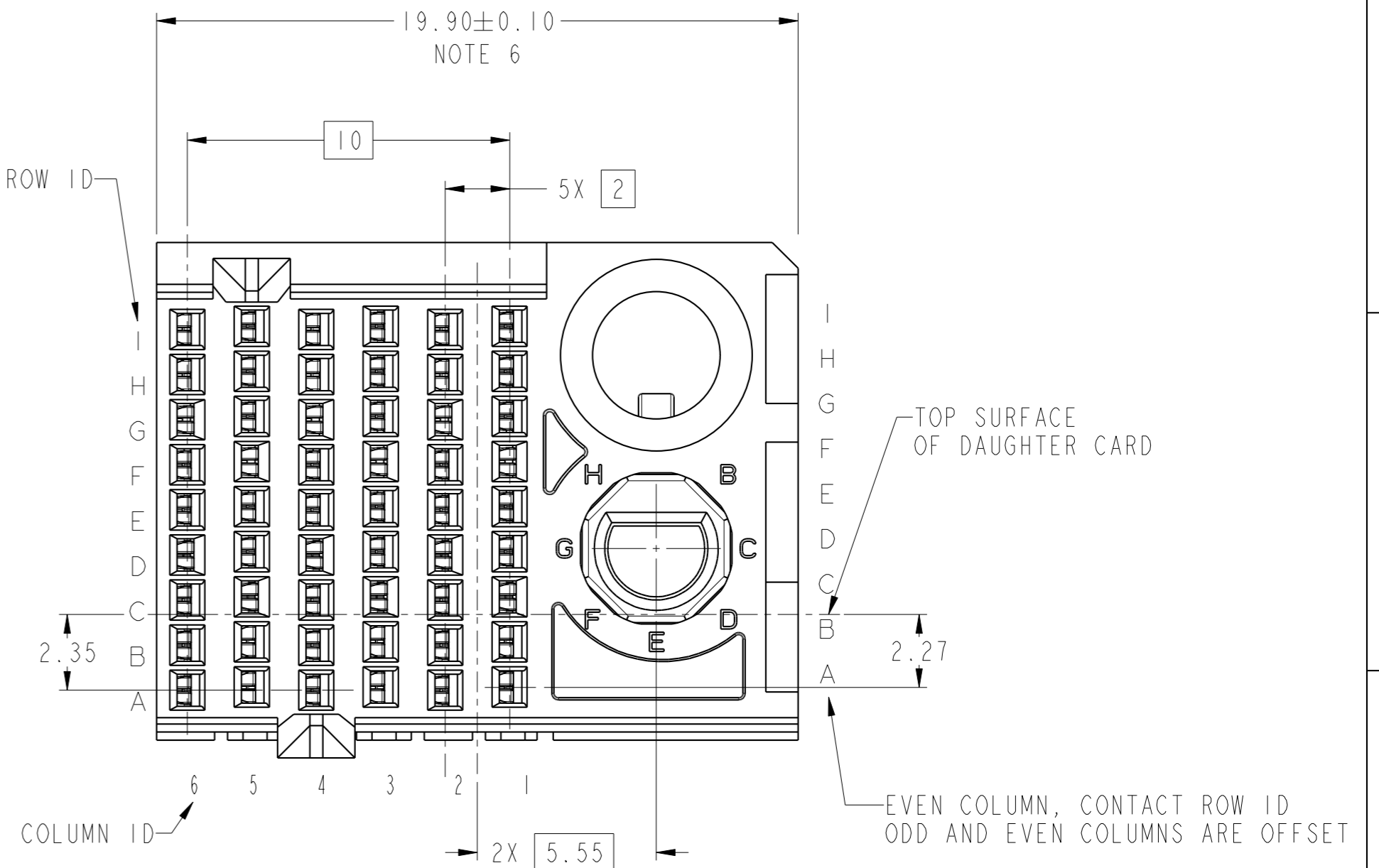
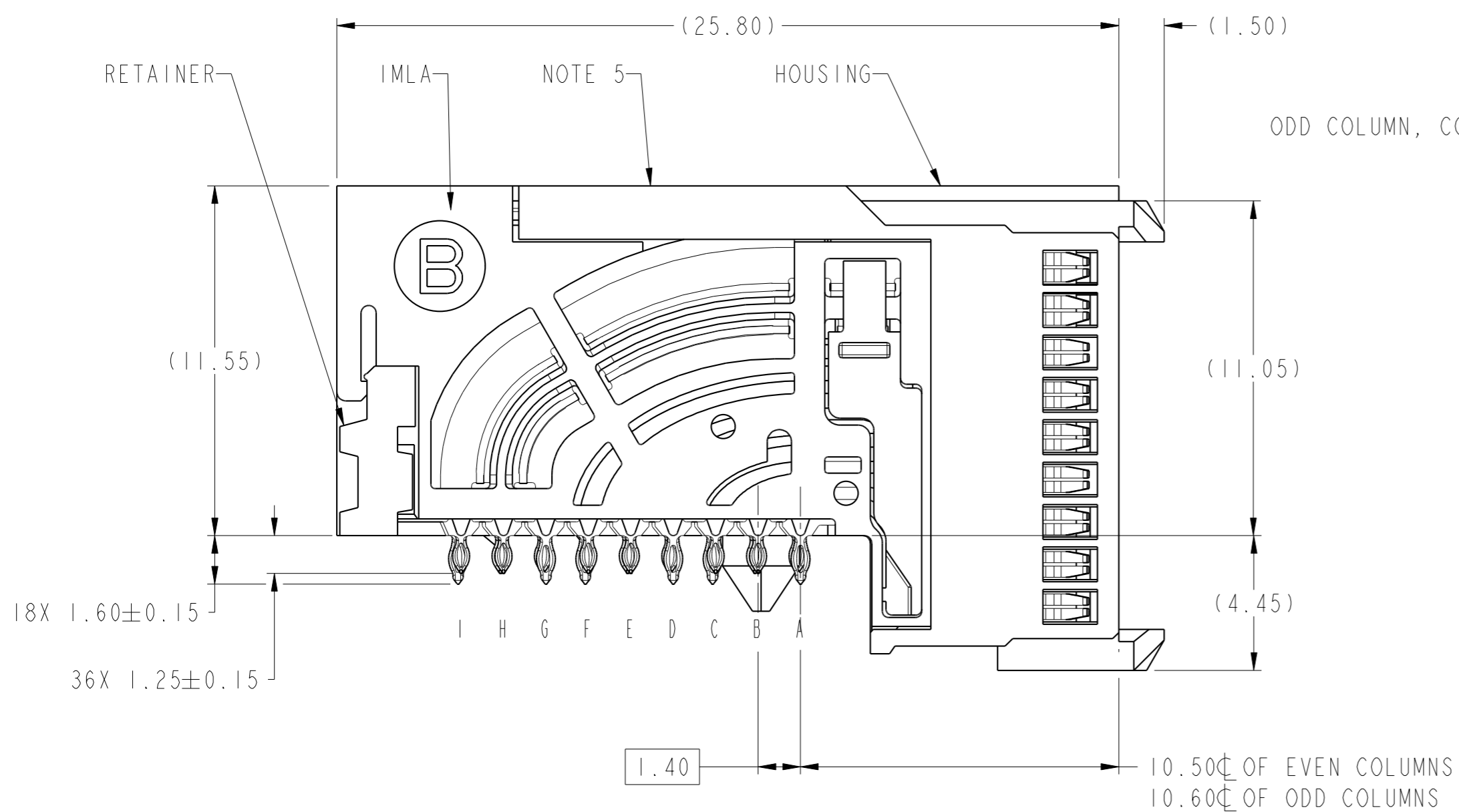

RECOMMENDED PCB LAYOUT

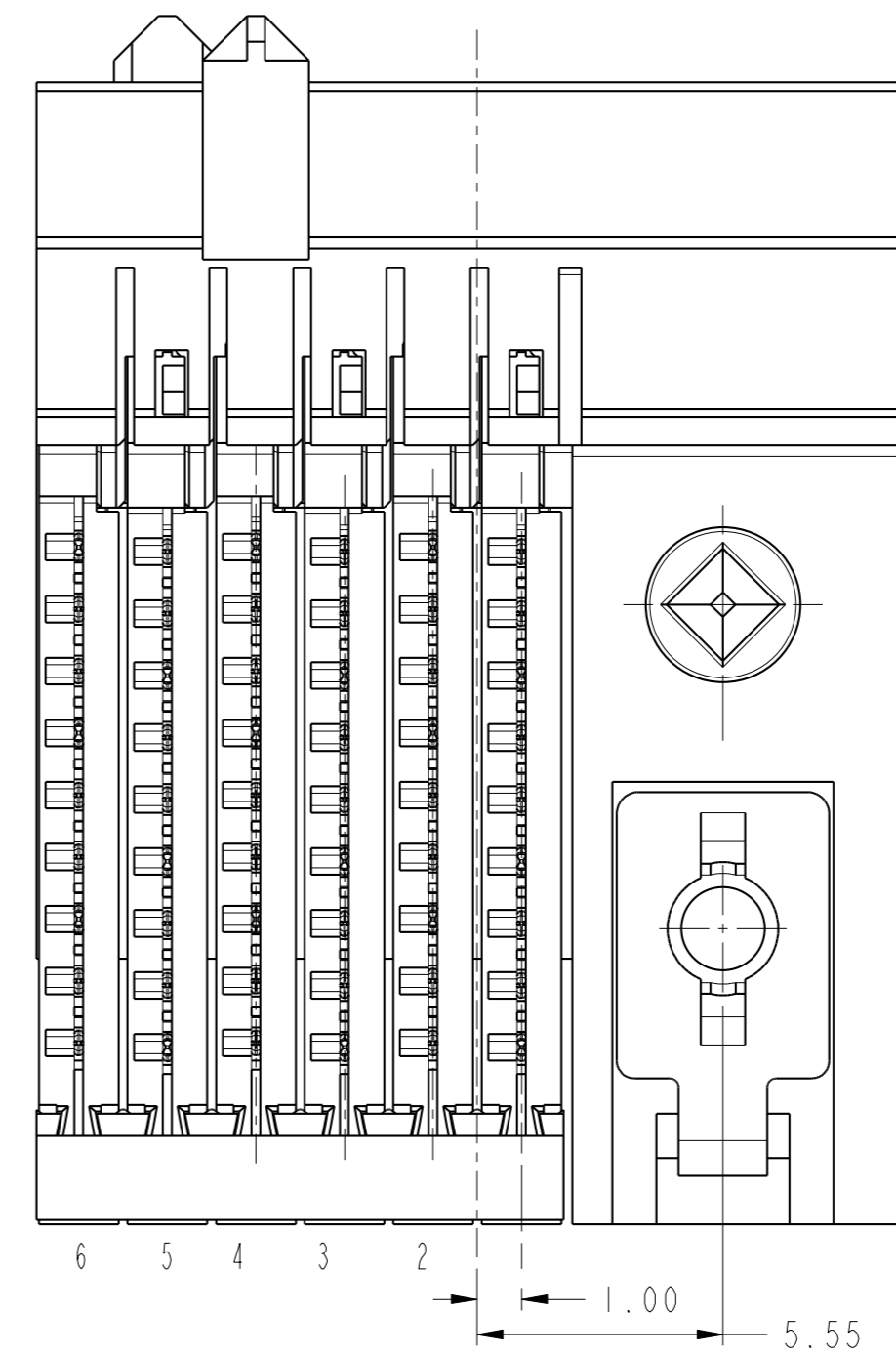

spec ref	---	dr	Jeny Ren	20150520	projection	MM	size	A2	scale	8:1
tolerance std	ASME Y14.5M	eng	Terry Luo	2019/01/31			ecn no	-	rel level	Released
TOLERANCES UNLESS OTHERWISE SPECIFIED		chr	Stone Li	2019/01/31						
surface	linear	0.X	±.3		product family	AIRMAX VS2	title AIRMAX VSE R.A. RECEPTACLE ASS'Y, 3 PAIR, 54 POS, 6 IMLA, 20MM, W/GUIDE/KEY cat. no.	dwg no 10135262	rev A	
		0.XX	±.15		Product - Customer Drw	sheet 3 of 4				
		0.XXX	±.050							
	angular	0°	±°							

PDS: Rev :A

STATUS:Released

Printed: Jan 31, 2019

PRODUCT NUMBER	PRESS-FIT TAIL PLATING TYPE
10135262-10*LF	TIN OVER NICKEL (LEAD FREE)

A

B

C

D

E

F

- 1 - CONNECTOR MATERIALS:
HOUSING: HIGH TEMP THERMOPLASTIC, NATURAL, UL94-V0
IMLA PLASTIC: HIGH TEMP THERMOPLASTIC, BLACK, UL94-V0
CONTACT: COPPER ALLOY
ORGANIZER: HIGH TEMP THERMOPLASTIC, WHITE, UL94-V0
- 2 - CONTACT PLATING:
SEPARABLE INTERFACE:
PERFORMANCE-BASED PLATING, QUALIFIED TO MEET THE REQUIREMENTS OF FCI PRODUCT SPECIFICATION GS-12-0956 INCLUDING TELCORDIA GR-1217-CORE (NOVEMBER 1995) CENTRAL OFFICE TEST SEQUENCE
- PRESS-FIT TAILS: SEE TABLE

- 3 - PRODUCT SPECIFICATION: GS-12-0956
- 4 - APPLICATION SPECIFICATION: GS-20-0305.
- 5 - PRODUCT MARKING, (PART NUMBER & LOT CODE), ON THIS SURFACE.
- 6 - THE MINIMUM CENTERLINE SPACING BETWEEN ADJACENT MODULES IS 20.0 MM.
- 7 - CONNECTOR OUTLINE MAY BE SCREEN PRINTED ONTO CUSTOMER PCB TO BE USED AS A GUIDE FOR MANUAL CONNECTOR PLACEMENT.
- 8 - REFER TO CUSTOMER DRAWING 10104444 FOR INFORMATION ON PCB HOLE DIAMETERS AND PLATING OPTIONS
- 9 - LEAD FREE PRODUCT MEETS THE EUROPEAN UNION DIRECTIVES & OTHER COUNTRY REGULATIONS AS DESCRIBED IN GS-22-008
- 10 - PACKAGING MEETS GS-14-920 LEAD FREE LABELING SPECIFICATION.
- 11 - GROUND CONTACTS (C, F, AND I IN ODD COLUMNS AND A, D, AND G, EVEN COLUMNS) REQUIRE (Ø0.500) FINISHED HOLES. SIGNAL LOCATIONS REQUIRE (Ø0.400) FINISHED HOLES.
- 12 - THESE OUTER VIAS (J) ARE OPTIONAL. WHILE NO CONNECTOR EONS ARE PRESSED INTO THESE HOLES WE RECOMMEND (Ø0.500) FINISHED HOLES AT THESE LOCATIONS TO PROVIDE GROUND SYMMETRY THROUGH THE PCB.
- 13 - CUSTOMER CAN FIX THE CONNECTOR WITH THREAD FORMING SCREW THROUGH THIS PTH. THE SCREW IS #2-32, THE VALID LENGTH OF SCREW IS 4.5MM PLUS THE THICKNESS OF PCB.

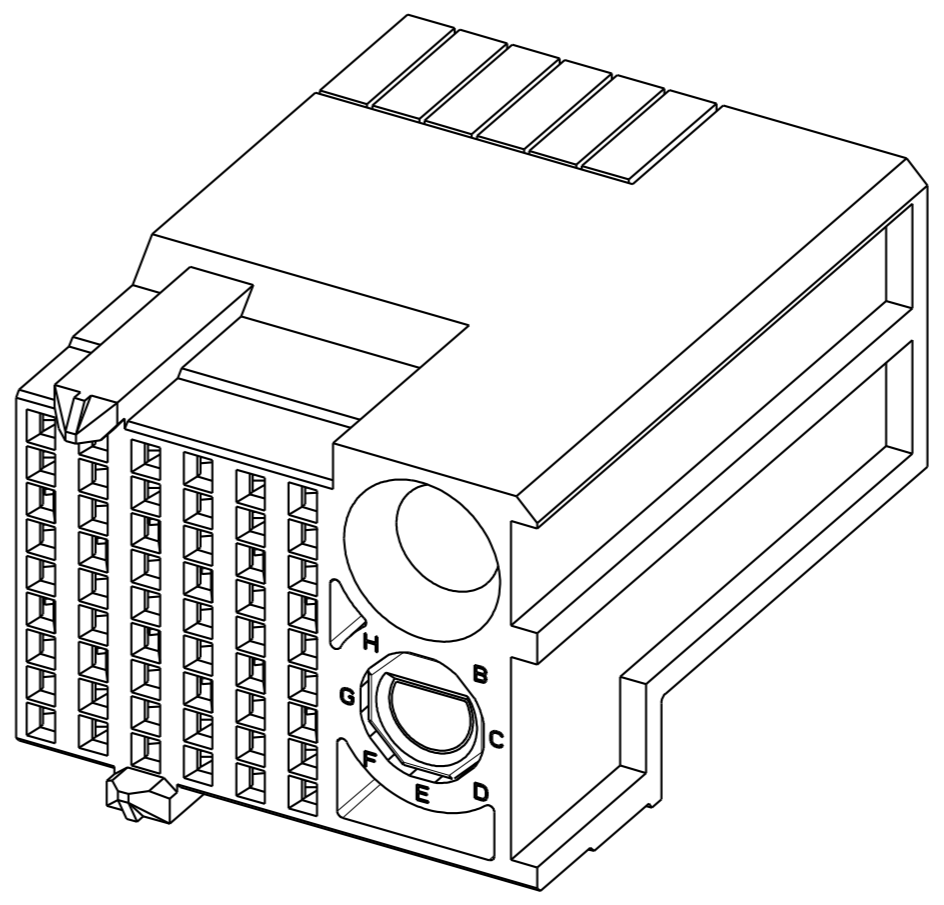

10135262-10ALF

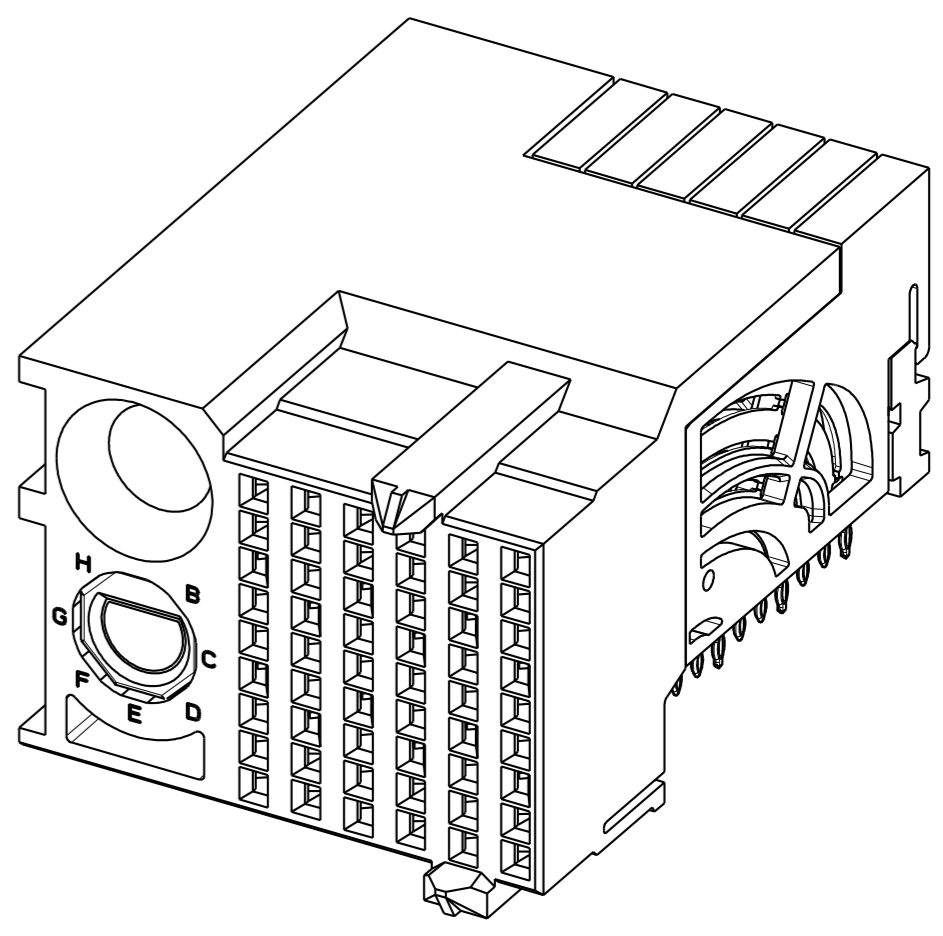

10135262-10PLF

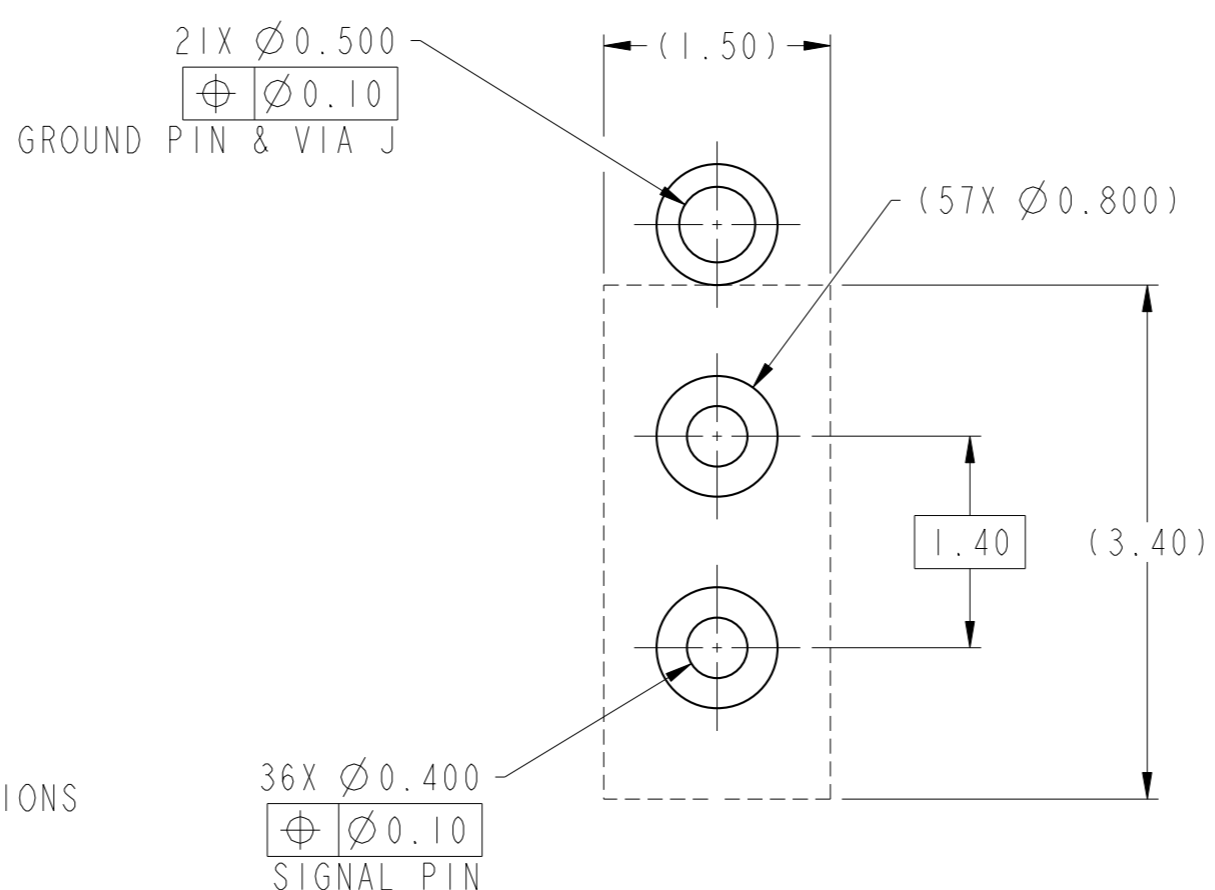
DETAIL A
SCALE 20:1

spec ref	---	dr	Jeny Ren	2015/05/20	projection	MM	size	A2	scale	6:1	
tolerance std	ASME Y14.5M	eng	Terry Luo	2019/01/31			ecn no	-	rel level	Released	
TOLERANCES UNLESS OTHERWISE SPECIFIED		chr	Stone Li	2019/01/31							
surface	linear	0.X	±.3		product family	AirMax VS2	dwg no	10135262	rev	A	
		0.XX	±.15		title	AIRMAX VSE R.A. RECEPTACLE		cat. no.	-	Product - Customer Drw	sheet 4 of 4
		0.XXX	±.050		ASS'Y, 3 PAIR, 54 POS, 6 IMLA, 20MM, W/GUIDE/KEY						
	angular	0°	±°								

PDS: Rev :A

STATUS:Released

Printed: Jan 31, 2019

Amphenol FCI

© 2016 AFCI