

# **K-Band Doppler Sensor Module**

RF Frequency: 24.05 to 24.25 GHz

Model No. NJR4262

Specifications

Rev.00-02 February 26, 2013

## **Copyright 2013**

New Japan Radio Co., Ltd.  
Microwave Components Division

-Notice of Proprietary Information-

This document and its contents are proprietary to New Japan Radio Co., Ltd.  
This publication and its contents may not be reproduced or distributed for any  
other purpose without the written permission of New Japan Radio Co., Ltd.



## Caution

1. NJRC strives to produce reliable and high quality microwave components. NJRC's microwave components are intended for specific applications and require proper maintenance and handling. To enhance the performance and service of NJRC's microwave components, the devices, machinery or equipment into which they are integrated should undergo preventative maintenance and inspection at regularly scheduled intervals. Failure to properly maintain equipment and machinery incorporating these products can result in catastrophic system failures.
2. To ensure the highest levels of reliability, NJRC products must always be properly handled. The introduction of external contaminants (e.g. dust, oil or cosmetics) can result in failures of microwave components.
3. NJRC offers a variety of microwave components intended for particular applications. It is important that you select the proper component for your intended application. You may contact NJRC's sales office or sales representatives, if you are uncertain about the products listed in the catalog and the specification sheets.
4. Special care is required in designing devices, machinery or equipment, which demand high levels of reliability. This is particularly important when designing critical components or systems whose foreseeable failure can result in situations that could adversely affect health or safety. In designing such critical devices, equipment or machinery, careful consideration should be given to, amongst other things, their safety design, fail-safe design, back-up and redundancy systems, and diffusion design.
5. The products listed in the catalog and specification sheets may not be appropriate for use in certain equipment where reliability is critical or where the products may be subjected to extreme conditions. You should consult our sales office or sales representatives before using the products in any of the following types of equipment.
  - \* Aerospace Equipment
  - \* Equipment Used in the Deep Sea
  - \* Power Generator Control Equipment (nuclear, steam, hydraulic)
  - \* Life Maintenance Medical Equipment
  - \* Fire Alarm/Intruder Detector
  - \* Vehicle Control Equipment (automobile, airplane, railroad, ship, etc.)
  - \* Various Safety Equipment
6. NJRC's products have been designed and tested to function within controlled environmental conditions. Do not use products under conditions that deviate from methods or applications specified in the catalog and specification sheets. Failure to employ NJRC's products in the proper applications can lead to deterioration, destruction or failure of the products. NJRC shall not be responsible for any bodily injury, fires or accidents, property damage or any consequential damages resulting from the misuse or misapplication of its products. PRODUCTS ARE SOLD WITHOUT WARRANTY OF ANY OF KIND, EITHER EXPRESS OR IMPLIED, INCLUDING BUT NOT LIMITED TO ANY IMPLIED WARRANTY OF MERCHANTABILITY OR FITNESS FOR A PARTICULAR PURPOSE.
7. The product specifications and descriptions listed in the catalog and specification sheets are subject to change at any time, without notice.

\* Above Specifications are subject to change without notice.

Category: K-Band Doppler Sensor Module  
 Type Name: NJR4262

Description:

- Motion detector using microwave doppler effect
- Miniaturized RF circuit with MMIC technology
- High accurate I-Q mixer

Specification:

1. Electric Characteristics (Common measure condition Ta= +25 deg.C)

Item	Specification			Unit	Condition / Note
	Min.	Typ.	Max.		
1.1 Operation voltage	3.3	-	5.5	V	
1.2 Operation current	-	45	55	mA	
1.3 Operation frequency	24.05	-	24.25	GHz	
1.4 E.I.R.P.	-	+16 (40)	+20 (100)	dBm (mW)	
1.5 Frequency Stability	-1	-	0	MHz/deg.C	Ta= -20 to +60 deg.C
1.6 Start-up time	-	4	6	msec	
1.7 2nd Harmonics (E.I.R.P.)	-	-	-30	dBm	
1.8 Radiation pattern	-	-	-	-	See Fig.1: Typical Radiation Pattern.
1.8.1 -3dB beam width (H-plane)	-	70	-	deg.	
1.8.2 -3dB beam width (V-plane)	-	28	-	deg.	
1.8.3 Side lobe suppression (H-plane)	-	-	-	dB	No side lobe
1.8.4 Side lobe suppression (V-plane)	-	13	-	dB	
1.9 Noise Voltage	-	-	400	mV	Upon amplified with 85dB Gain amp. Band width: 10 to 300Hz
1.10 Signal level	0.5	0.8	-	Vp-p	Refer to Fig.2 : Signal Test System
1.11 Offset voltage	1.1	1.35	1.6	V	
1.12 I-Q Amplitude Balance	-3	-	+3	dB	
1.13 I-Q Phase Balance	85	-	95	deg.	

Fig.1: Typical Radiation Pattern

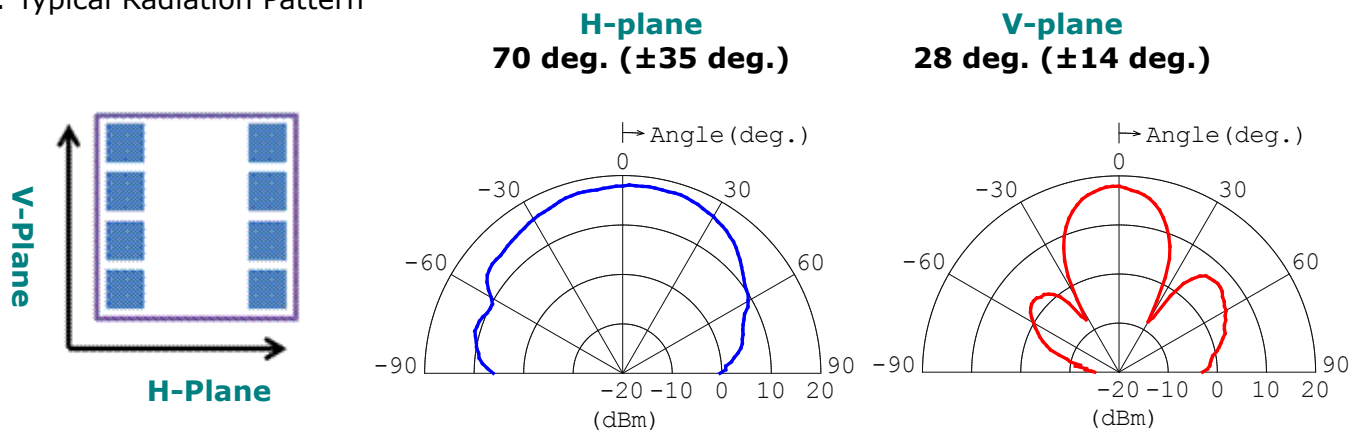

\* Above Specifications are subject to change without notice.

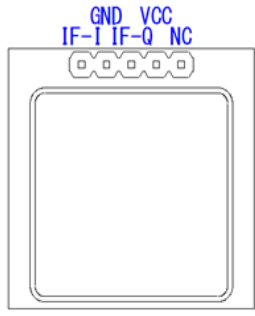
2. Mechanical characteristics													
Item	Specification												
2.1 Size	25(W) x 25(D) x 7.3(H) mm Tolerance: ±0.5 mm												
2.2 Weight	7 g max.												
2.3 Interface / Pin assignment	Pin Size: 0.64 mm square Pin Pitch: 2.54 mm  <table border="1" data-bbox="949 436 1436 683"> <thead> <tr> <th>Pin</th> <th>Description</th> </tr> </thead> <tbody> <tr> <td>IF-I</td> <td>Doppler signal output(I). Output impedance:1.5kohm</td> </tr> <tr> <td>GND</td> <td>GND</td> </tr> <tr> <td>IF-Q</td> <td>Doppler signal output(Q). Output impedance:1.5kohm</td> </tr> <tr> <td>VCC</td> <td>Voltage supply.</td> </tr> <tr> <td>NC</td> <td>No connection.</td> </tr> </tbody> </table>	Pin	Description	IF-I	Doppler signal output(I). Output impedance:1.5kohm	GND	GND	IF-Q	Doppler signal output(Q). Output impedance:1.5kohm	VCC	Voltage supply.	NC	No connection.
Pin	Description												
IF-I	Doppler signal output(I). Output impedance:1.5kohm												
GND	GND												
IF-Q	Doppler signal output(Q). Output impedance:1.5kohm												
VCC	Voltage supply.												
NC	No connection.												
Recommended via hole diameter: 1.2 ± 0.05 mm													

3. Environmental characteristics	
Item	Specification
3.1 Operation Temperature	-20 to +60 deg.C
3.2 Storage Temperature	-40 to +80 deg.C
3.3 Humidity	0 to 95 % @ +30 deg.C
3.4 Vibration	49.03 m/s <sup>2</sup> (5 G) 30 to 50 Hz, 10 minutes, XYZ direction
3.5 Shock	196.13 m/s <sup>2</sup> (20 G) Half sine, 11 msec, XYZ direction, 3 times

4. Absolute Maximum Rating					
Item	Specification			Unit	Condition / Note
	Min.	Typ.	Max.		
4.1 Supply voltage	0	-	7	V	
4.2 Operation Temperature	-40	-	+85	deg.C	No damage
4.3 Storage Temperature	-40	-	+85	deg.C	

\* Above Specifications are subject to change without notice.

## 5. Outline

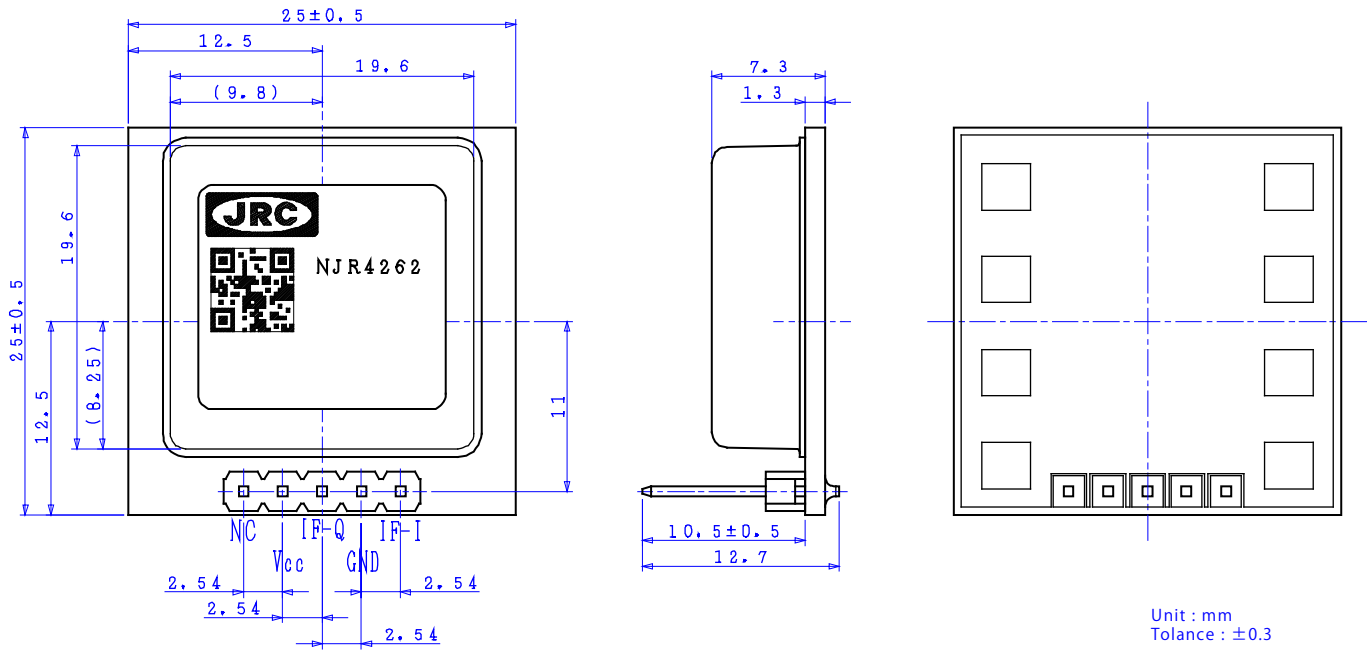

\* Above Specifications are subject to change without notice.

Fig2. Signal Test System

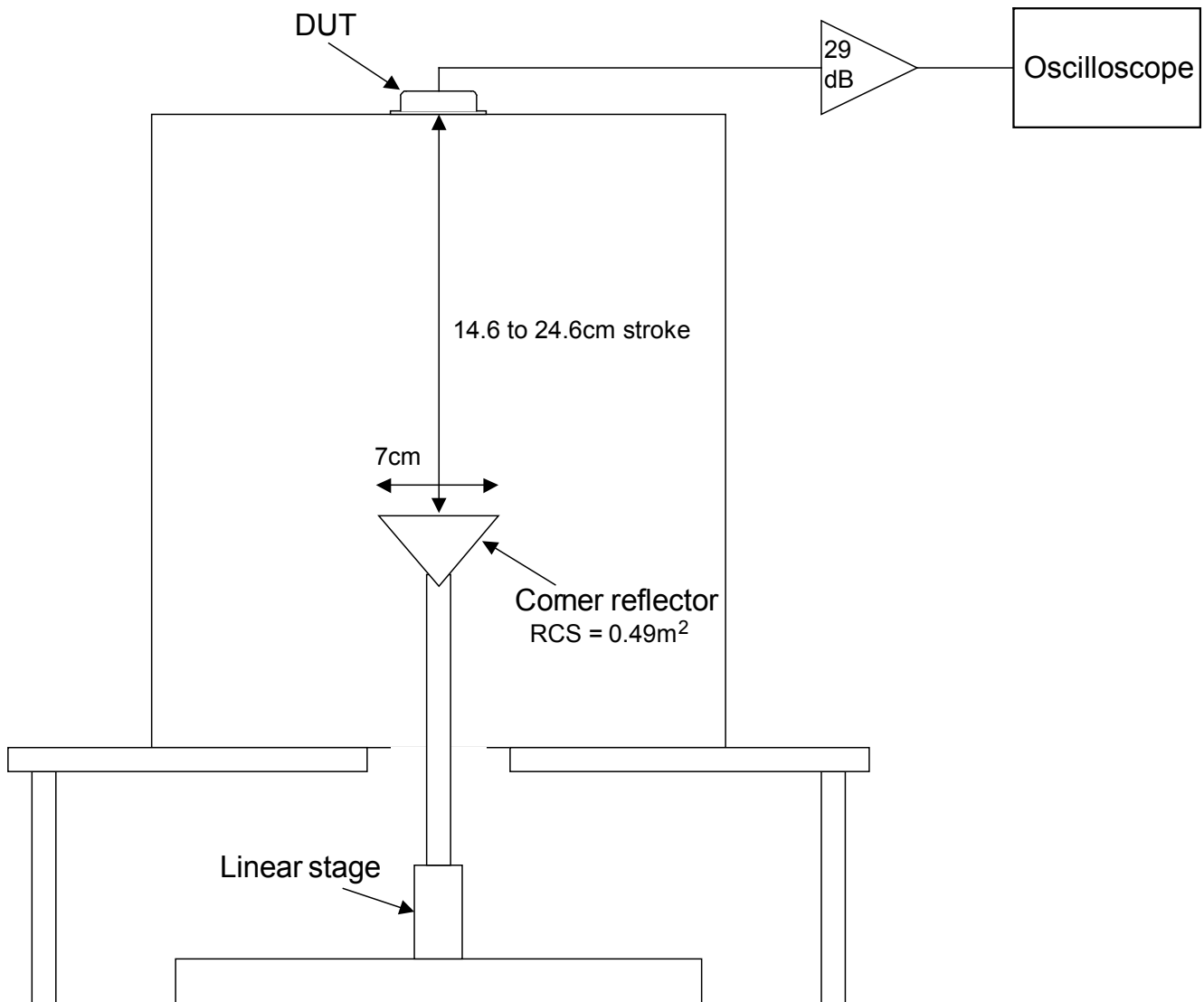

\* Above Specifications are subject to change without notice.

# Mouser Electronics

Authorized Distributor

Click to View Pricing, Inventory, Delivery & Lifecycle Information:

[NJR:](#)

[NJR4262F2P5](#) [NJR4262J](#) [NJR4262F1P5](#) [NJR4262](#) [NJR4262F3P5](#)