

REVISIONS		DATE	APPROVED
LTR	DESCRIPTION		
N/C	INITIAL RELEASE PER ECN# T-18988	94MAR16	Z.E.T.
A	REVISED PER ECN# T-20122		

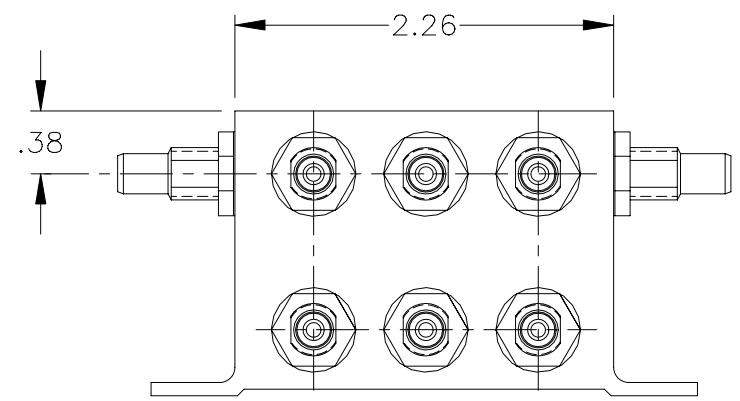
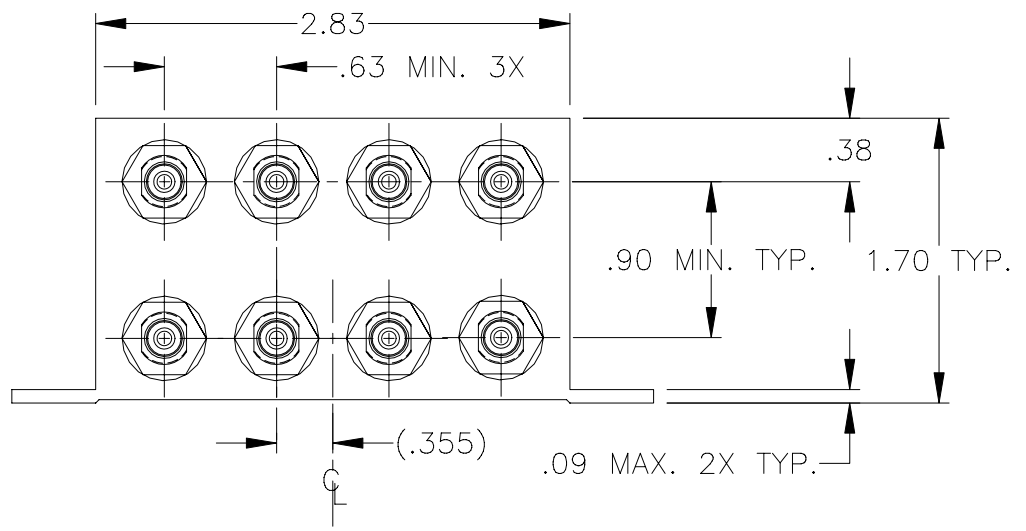
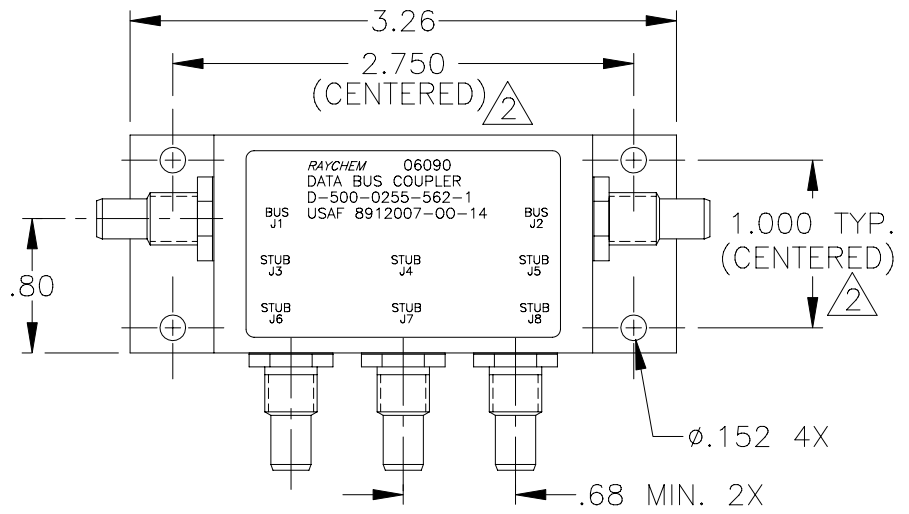
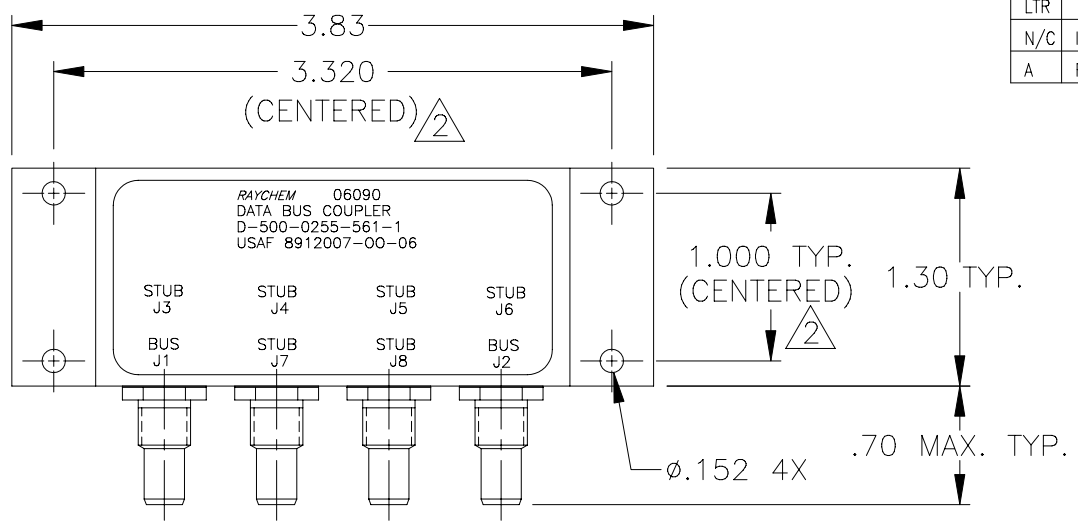

FACE MOUNT BUS CONFIGURATION
D-500-0255-561-1

SIDE MOUNT BUS CONFIGURATION
D-500-0255-562-1

SPECIFICATION CONTROL DRAWING

- 3 WEIGHT: D-500-0255-561-1 195 GRAMS MAX.
D-500-0255-562-1 178 GRAMS MAX.
- 2 HOLE PATTERN MACHINED SYMMETRIC TO MOUNTING FLANGE.
- 1. ORIENTATION OF CONNECTORS IS APPROXIMATELY AS SHOWN.

NOTES: If this document is printed it becomes uncontrolled.
Check for the latest revision.

UNLESS OTHERWISE SPECIFIED DIMENSIONS ARE IN INCHES. METRIC DIMENSIONS ARE IN BRACKETS.	DRAWN	J.B.K.	94MAR09	tyco Electronics	Tyco Electronics Corporation 300 Constitution Drive Menlo Park, CA. 94025 U.S.A.	Raychem				
	CHECKED	Z.E.T.	94MAR16							
	DECIMALS	.XXX ±.010	[— mm	TITLE	6 STUB, DATA BUS BOX COUPLER WITH THREADED TRIAXIAL CONNECTORS (FACE MOUNT & SIDE MOUNT BUS CONFIGURATION)					
	ANGLES	.XX ±.03	[— mm]	APPROVED	P.J.D.	94MAR16	SIZE	CODE IDENT. NO.	DWG. NO.	REV
WEIGHT			APPROVED			A	06090	D-500-0255-561/562-1	A	
			CAD NAME	009186-1.DWG			DO NOT SCALE THIS DRAWING	SHEET 1 OF 2		
			THIRD ANGLE PROJECTION							

1.0 INTERMATEABILITY

BUS JACKS J1 AND J2	MATING PLUG
DK-621-0412-P (8340711-00-01)	DK-621-0411-S (8340709-00-02)

STUB JACK J3 THRU J8	MATING PLUG
DK-621-0412-S (8340711-00-02)	DK-621-0411-P (8340709-00-01)

2.0 PERFORMANCE

- 2.1 THIS COUPLER IS DESIGNED TO MEET THE APPLICABLE FUNCTIONAL REQUIREMENT OF RAYCHEM SPECIFICATION D-6021 AND USAF 8912007.
- 2.2 THE COUPLER SHALL OPERATE UNDER ANY OF THE ENVIRONMENTAL SERVICE CONDITIONS AS SPECIFIED IN MIL-E-5400, CLASS ∇ UPGRADED TO 125°C CONTINUOUS OPERATION.
- 2.3 ALTITUDE: SEA LEVEL TO 75,000 FEET

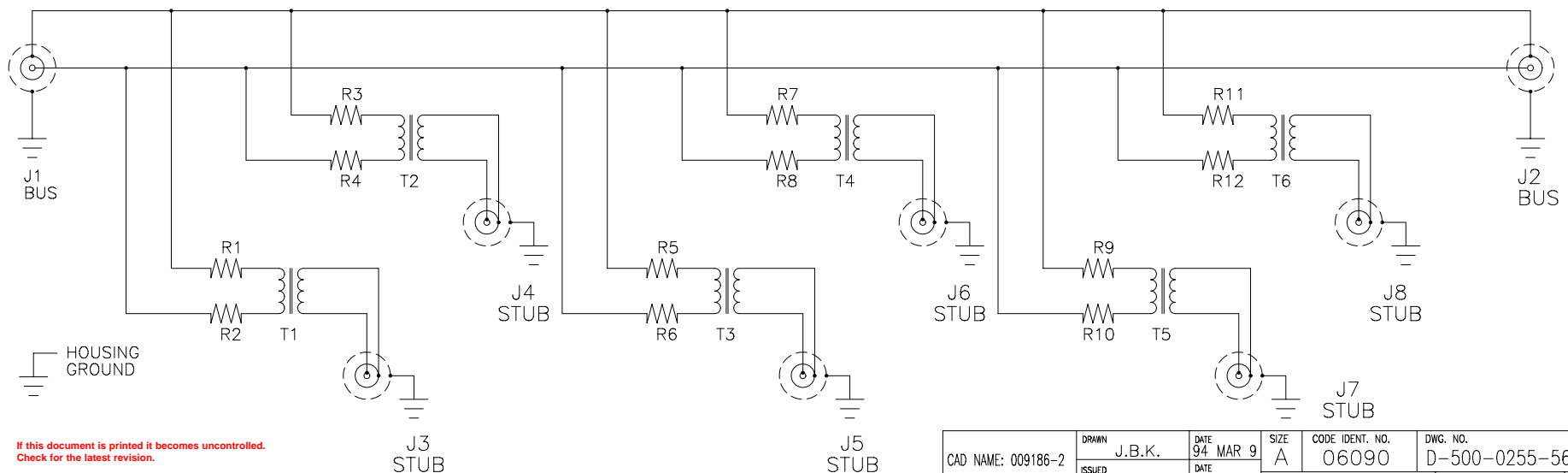
SCHEMATIC DIAGRAM

If this document is printed it becomes uncontrolled.
Check for the latest revision.

CAD NAME: 009186-2	DRAWN J.B.K.	DATE 94 MAR 9	SIZE A	CODE IDENT. NO. 06090	DWG. NO. D-500-0255-561/562-1
	ISSUED	DATE	DO NOT SCALE THIS DRAWING		SHEET 2 OF 2