

**SMP-MAX FEMALE SLIDE TYPE - SMP FEMALE
STRAIGHT ADAPTER**

R191.996.110

Série : ADAPTER

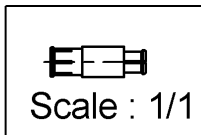
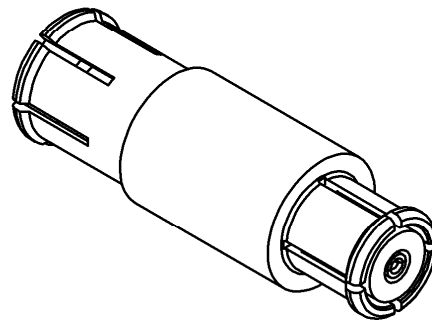
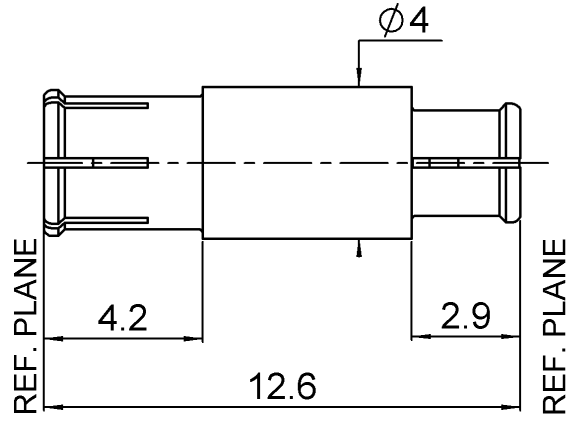

All dimensions are in mm.

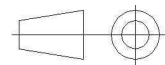

COMPONENTS	MATERIALS	PLATING (μm)
BODY	BERYLLIUM COPPER	NPGR
CENTER CONTACT	BERYLLIUM COPPER	NPGR
OUTER CONTACT		
INSULATOR	PTFE	
GASKET		
OTHERS PARTS		
-	-	-
-	-	-

Issue : 1107 A

In the effort to improve our products, we reserve the rights to make changes judged to be necessary.



SMP-MAX FEMALE SLIDE TYPE - SMP FEMALE

R191.996.110

STRAIGHT ADAPTER

Série : **ADAPTER**

PACKAGING

SPECIFICATION

Standard	Unit	Other
100	'W' option	Contact us

ELECTRICAL CHARACTERISTICS

ENVIRONMENTAL

Impedance	50	Ω
Frequency	0-6	GHz
VSWR	1.25* + 0,0000	x F(GHz) Maxi
Insertion loss	0.15*	\sqrt{F} (GHz) dB Maxi
RF leakage	- (NA)	- F(GHz)) dB Maxi
Voltage rating	335	Veff Maxi
Dielectric withstanding voltage	500	Veff mini
Insulation resistance	5000	M Ω mini

Operating	-55/+125	$^{\circ}$ C
Hermetic seal	NA	Atm.cm3/s
Panel leakage	NA	

MECHANICAL CHARACTERISTICS

OTHER CHARACTERISTICS

Center contact retention		
Axial force – Mating end	7	N mini
Axial force – Opposite end	7	N mini
Torque	NA	N.cm mini
Recommended torque		
Mating	SMP-MAX	0 N.cm
	SMP-COM	0 N.cm
		0 N.cm
Panel nut	NA	N.cm
Mating life	100	Cycles mini
Weight	0,6230	g

*VSWR: up to 3GHz; 3-6GHz,1.35max
 *Coaxial Transmission Line Only
 *Slide type receptacle+Bullet+Snap type receptacle
 Typical VSWR(Board to Board connection):
 0-3GHz, 1.2max
 Power handling (typical) : >120W@3GHz at 25°C
 Radial working angle: 3°min
 Axial working range : 2mm

Issue : **1107** **A**

In the effort to improve our products, we reserve the rights to make changes judged to be necessary.



SMP-MAX FEMALE SLIDE TYPE - SMP FEMALE

R191.996.110

STRAIGHT ADAPTER

Série : ADAPTER

SMP-MAX connecting range

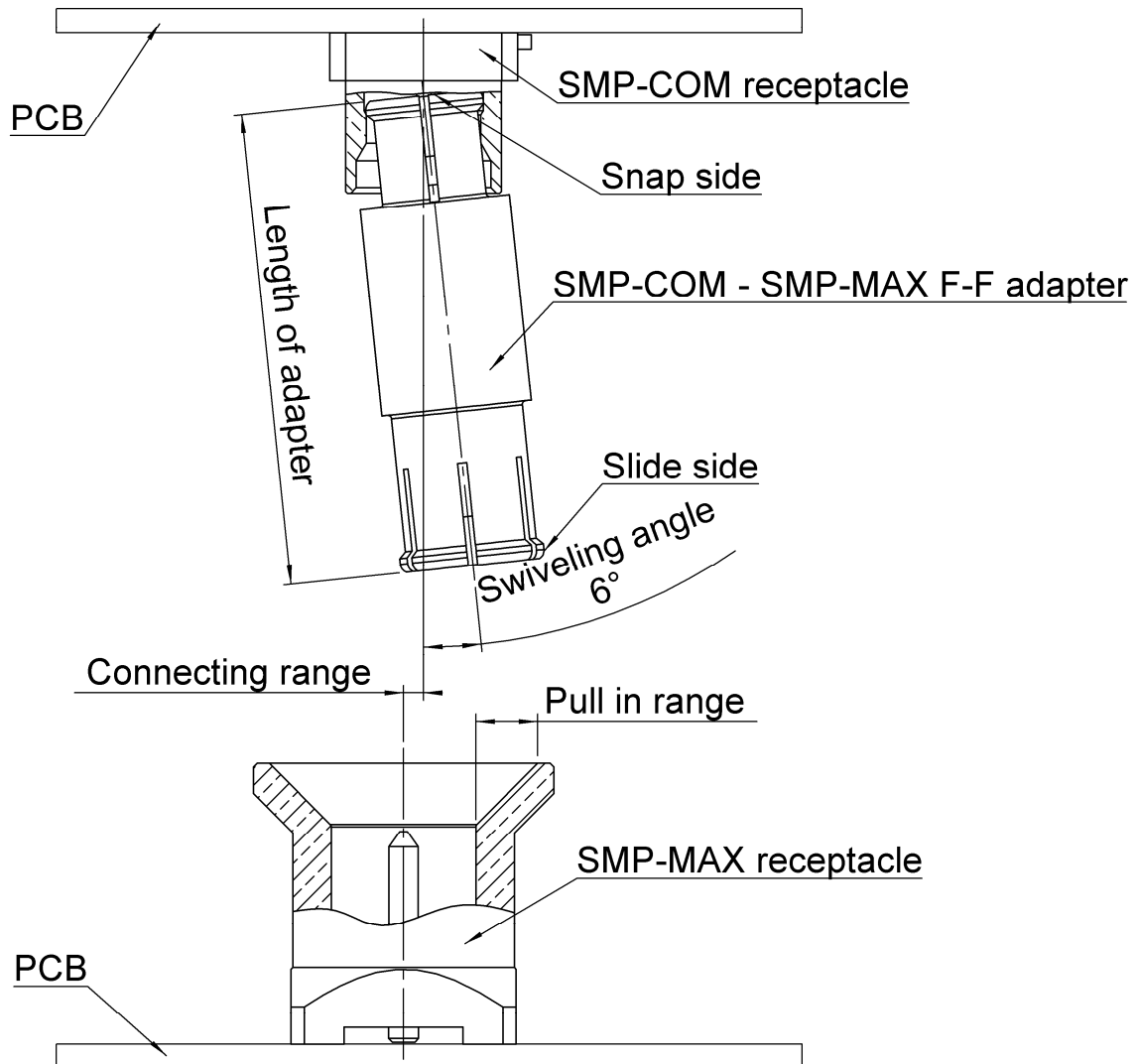

The connecting range represents the maximum misalignment during connection.

The swiveling angle is the maximum possible angle of the adapter in a snap receptacle.

A blind assembly is guaranteed if radial misalignment is smaller than connecting range. Otherwise a manual lead-in is necessary.

Issue : 1107 A

In the effort to improve our products, we reserve the rights to make changes judged to be necessary.

RADIALL 

SMP-MAX FEMALE SLIDE TYPE - SMP FEMALE

R191.996.110

STRAIGHT ADAPTER

Série : ADAPTER

SMP-MAX radial and axial working range

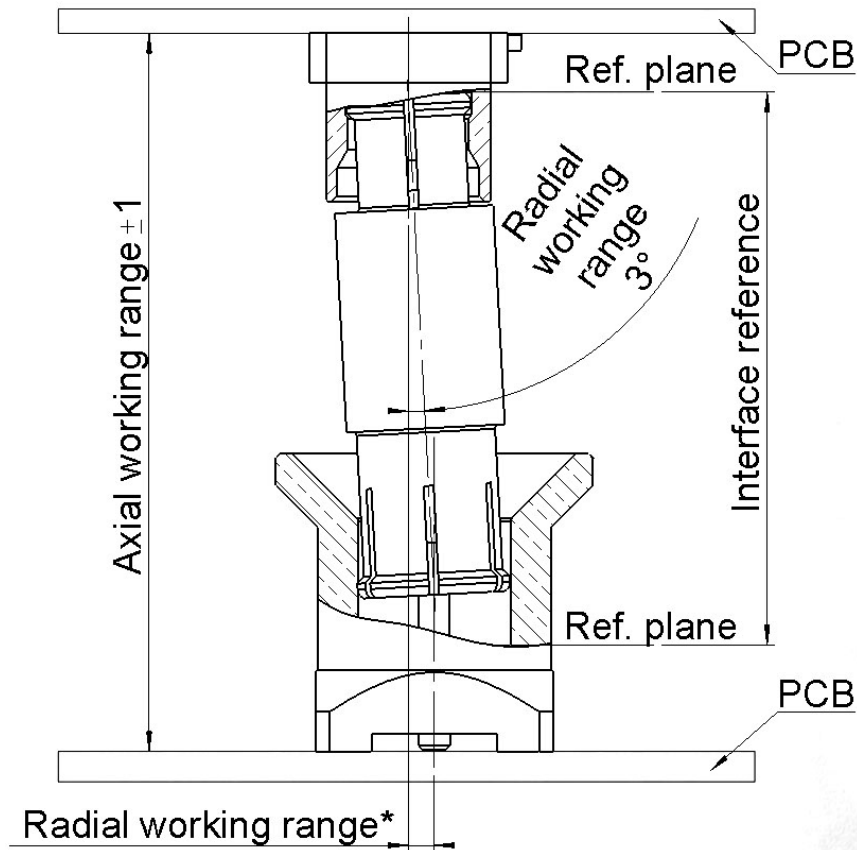

Electrical performance is achieved when radial and axial misalignments are within their working ranges.

* Radial working range = (length of the adapter)* Sin(radial working angle).

Issue : 1107 A

In the effort to improve our products, we reserve the rights to make changes judged to be necessary.

RADIALL 