

AVERY DENNISON MARKETING SPECIFICATION

HISTORY

THE SUBJECT MATTER DISCLOSED HEREIN EMBODIES PROPRIETARY INFORMATION WHICH IS THE CONFIDENTIAL PROPERTY OF THE AVERY DENNISON CO. NONE OF WHICH SHALL BE COPIED, REPRODUCED, DISCLOSED TO OTHERS, PUBLISHED OR USED IN WHOLE OR IN PART, FOR ANY PURPOSE OTHER THAN THAT FOR WHICH IT IS BEING MADE AVAILABLE WITHOUT THE EXPRESS ADVANCE WRITTEN PERMISSION OF A DULY AUTHORIZED AGENT OF THE COMPANY. THIS DOCUMENT IS THE PROPERTY OF THE AVERY DENNISON CO. AND IS TO BE RETURNED TO THE COMPANY ON DEMAND.

| REV. | DATE | DESCRIPTION |
|------|----------|--------------------------------------------------------------------------|
| N | 07.15.09 | UPDATE MATERIAL DESCRIPTION |
| 0 | 09.23.14 | CHG DIM 1 TO BE TAKEN FROM BOTTOM OF THE HEAD. MADE MM THE PRIMARY UNITS |

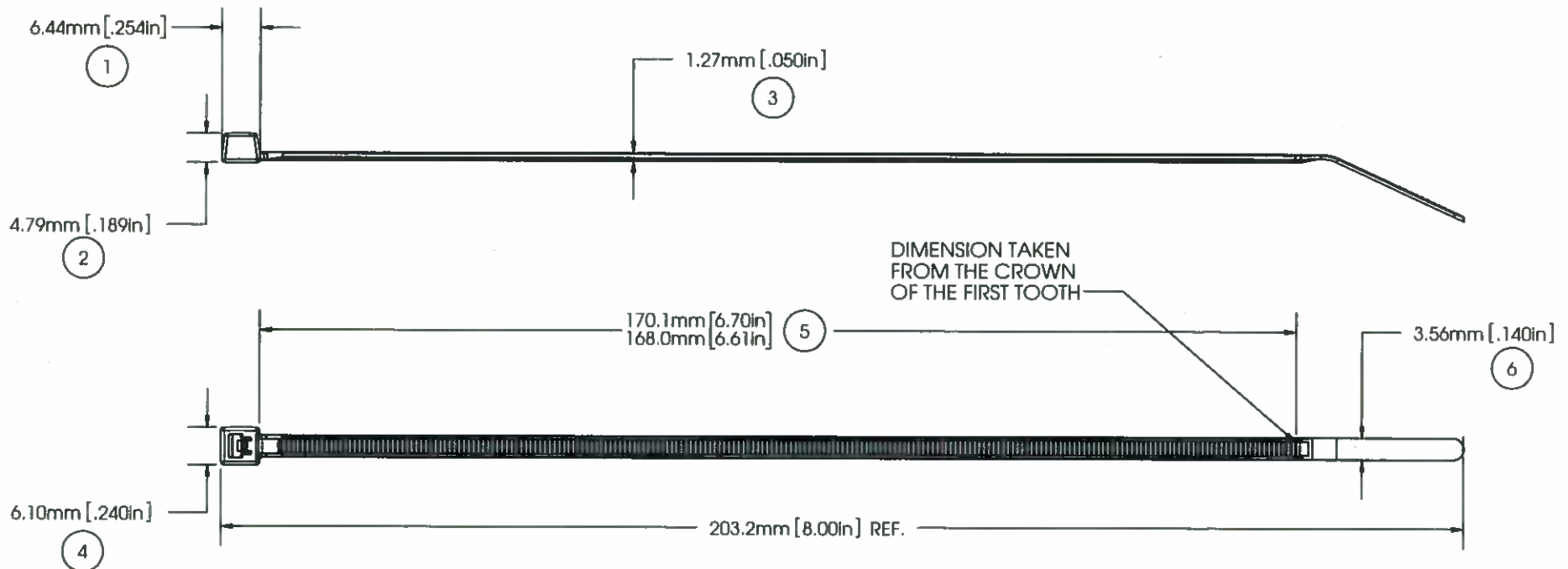

NOTE: THESE CABLE TIES ARE UV RATED AND HAVE A FLAMMABILITY RATING OF V-2

| | |
|-------------------------|--------------------------------------------------------------------|
| MILITARY STANDARD: | MS-3367-5-0 |
| LOOP TENSILE STRENGTH: | 40 LBF /180N MIN. PER AS-23190 |
| OPERATING TEMP: | -40°F(-40°C) TO 176°F (80°C) |
| MIN. INSTALLATION TEMP: | 32°F(0°C) |
| WEIGHT: | 0.036 OZ./1.02 GRAMS |
| BUNDLE DIAMETER: | Ø 1.6MM TO Ø 54.0MM |
| TOOL: | 12001 - HAND INSTALLATION TOOL 12500 - PNUEM. INSTALLATION TOOL |
| TOOL TENSION SETTING: | 3-5 |
| PACKAGING: | 1000/BAG, 5000/CASE |

| | |
|------------|---------------------------------------|
| APPROVALS: | ENG. APPR. <i>[Signature]</i> 9/23/14 |
| | Q.A. APPR. <i>[Signature]</i> 9/23/14 |



| | | | |
|---------------------------|--------------|------------------------------|-------------------------|
| SPECIFIED TOLERANCES ARE: | | MATERIAL | DESCRIPTION |
| .XX ± .03 IN. | .X ± .7 MM | NYLON 6/6, WEATHER RESISTANT | 8" CABLE TIE, INTERMED. |
| .XXX ± .010 IN. | .XX ± .25 MM | COLOR | STOCK NO. |
| ANGULAR: ± 2° | | BLACK | 08380-0 |
| | | | REV. 0 |

5

4

3

2

1