

NHD-C12865BZ-RN-FBW

COG (Chip-On-Glass) Liquid Crystal Display Module

NHD-	Newhaven Display
C12865-	128 x 65 pixels
BZ-	Model
R-	Reflective
N-	No Backlight
F-	FSTN (+)
B-	6:00 view
W-	Wide Temp (-20°C ~ +70°C)
	RoHS Compliant

Newhaven Display International, Inc.

2511 Technology Drive, Suite 101

Elgin IL, 60124

Ph: 847-844-8795

Fax: 847-844-8796

www.newhavendisplay.com

nhtech@newhavendisplay.com

nhsales@newhavendisplay.com

Document Revision History

Revision	Date	Description	Changed by
0	5/17/2007	Initial Release	-
1	9/21/2009	User guide reformat	BE
2	10/14/2009	Updated Electrical Characteristic	MC
3	12/16/2009	Mechanical Drawing pin update	BE

Functions and Features

- 128 x 65 pixels
- Built-in SPLC501C controller
- +3.0V power supply
- 1/65 duty cycle; 1/9 bias
- Parallel/Serial Interface
- RoHS Compliant

Mechanical Drawing

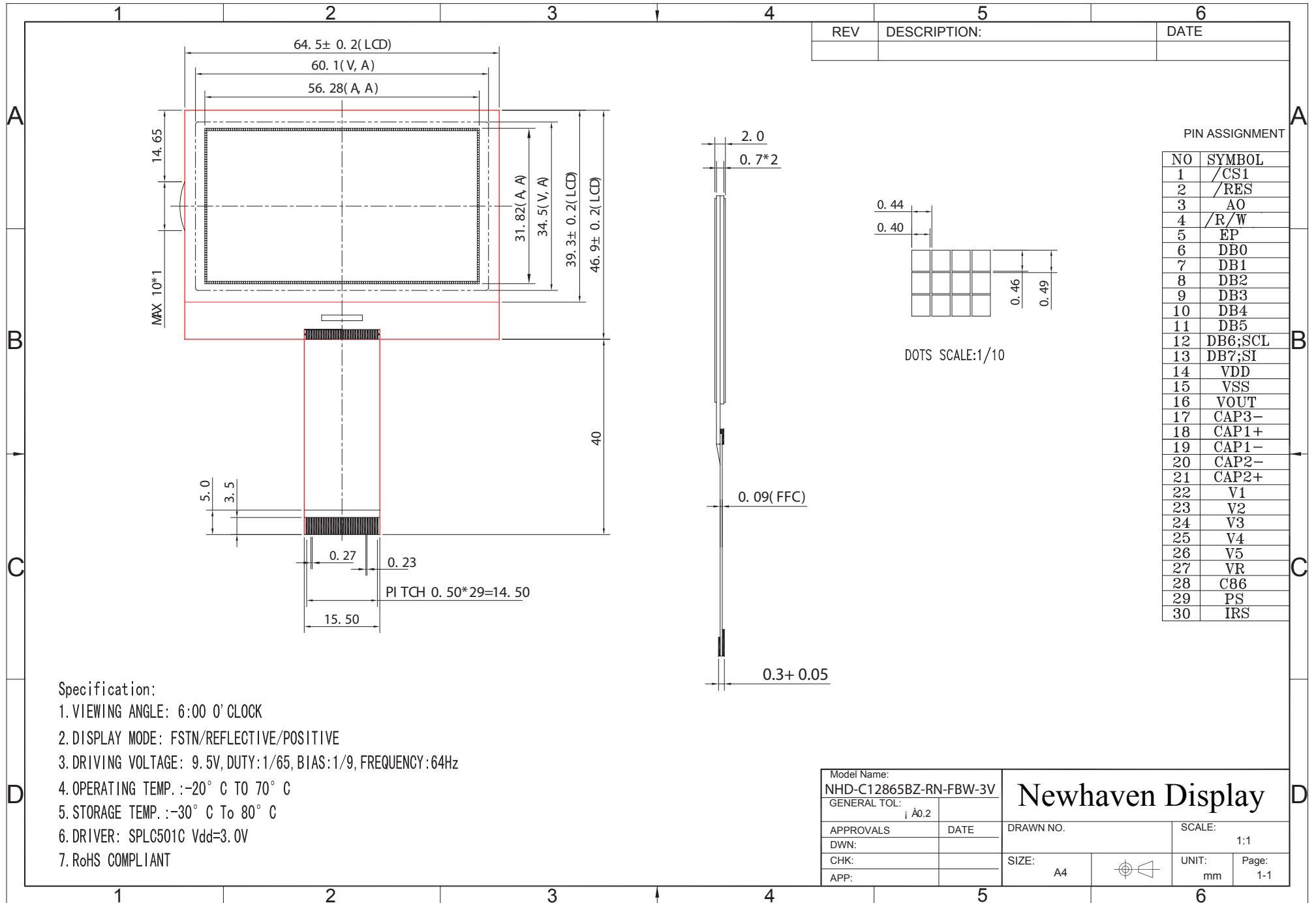

REV	DESCRIPTION:	DATE

PIN ASSIGNMENT

NO	SYMBOL
1	/CS1
2	/RES
3	AO
4	/R/W
5	EP
6	DB0
7	DB1
8	DB2
9	DB3
10	DB4
11	DB5
12	DB6;SCL
13	DB7;SI
14	VDD
15	VSS
16	VOUT
17	CAP3-
18	CAP1+
19	CAP1-
20	CAP2-
21	CAP2+
22	V1
23	V2
24	V3
25	V4
26	V5
27	VR
28	C86
29	PS
30	IRS

Specification:

- VIEWING ANGLE: 6:00 O' CLOCK
- DISPLAY MODE: FSTN/REFLECTIVE/POSITIVE
- DRIVING VOLTAGE: 9.5V, DUTY:1/65, BIAS:1/9, FREQUENCY:64Hz
- OPERATING TEMP.: -20° C TO 70° C
- STORAGE TEMP.: -30° C To 80° C
- DRIVER: SPLC501C Vdd=3.0V
- RoHS COMPLIANT

Model Name: NHD-C12865BZ-RN-FBW-3V		<h2>Newhaven Display</h2>	
GENERAL TOL: i Å0.2			
APPROVALS	DATE	DRAWN NO.	SCALE: 1:1
DWN:			
CHK:		SIZE: A4	UNIT: mm
APP:			Page: 1-1

Pin Description and Wiring Diagram

Pin No.	Symbol	External Connection	Function Description
1	/CS1	MPU	Active LOW Chip select
2	/RESET	MPU	Active LOW Reset signal
3	A0	MPU	Register select signal. A0=1: Data, A0=0: Command
4	/RW	MPU	Read/Write select signal, R/W=1: Read R/W=0: Write
5	E	MPU	Operation enable signal. Falling edge triggered.
6	DB0	MPU	Parallel Interface
7	DB1	MPU	DB0-DB7: Bi-directional 8-bit data bus
8	DB2	MPU	
9	DB3	MPU	Serial Interface:
10	DB4	MPU	DB0-DB5: No connect in serial mode
11	DB5	MPU	
12	DB6	MPU	DB6= Serial clock (CLK)
13	DB7	MPU	DB7= Serial data input (SDA)
14	VDD	Power Supply	Power supply for LCD and logic (+3.0V)
15	Vss	Power Supply	Ground
16	VOUT	Power Supply	Voltage booster circuit – connect to 1uF cap to Vss or VDD
17	CAP3-	Power Supply	Connect to 1uF Cap to CAP1+ (Pin-18)
18	CAP1+	Power Supply	Connect to 1uF Cap to CAP1-(Pin-19) and CAP3-(Pin17)
19	CAP1-	Power Supply	Connect to 1uF Cap to CAP1+ (Pin-18)
20	CAP2-	Power Supply	Connect to 1uF Cap to CAP2+ (Pin-21)
21	CAP2+	Power Supply	Connect to 1uF Cap to CAP2- (Pin-20)
22	V1	Power Supply	1.0uF-2.2uF cap to VSS
23	V2	Power Supply	1.0uF-2.2uF cap to VSS
24	V3	Power Supply	1.0uF-2.2uF cap to VSS
25	V4	Power Supply	1.0uF-2.2uF cap to VSS
26	V5	Power Supply	1.0uF-2.2uF cap to VSS
27	VR	-	No Connect
28	C86	MPU	Select MPU interface pin. C86 = H: 6800; C86 = L: 8080
29	PS	MPU	Parallel/Serial select. PS = H: Parallel; PS = L: Serial
30	IRS	MPU	This terminal selects the resistors for the V5 voltage level adjustment

Recommended LCD connector: 0.5mm pitch, 30 pin FFC. Molex p/n: 52892-3095

Backlight connector: -- Mates with: --

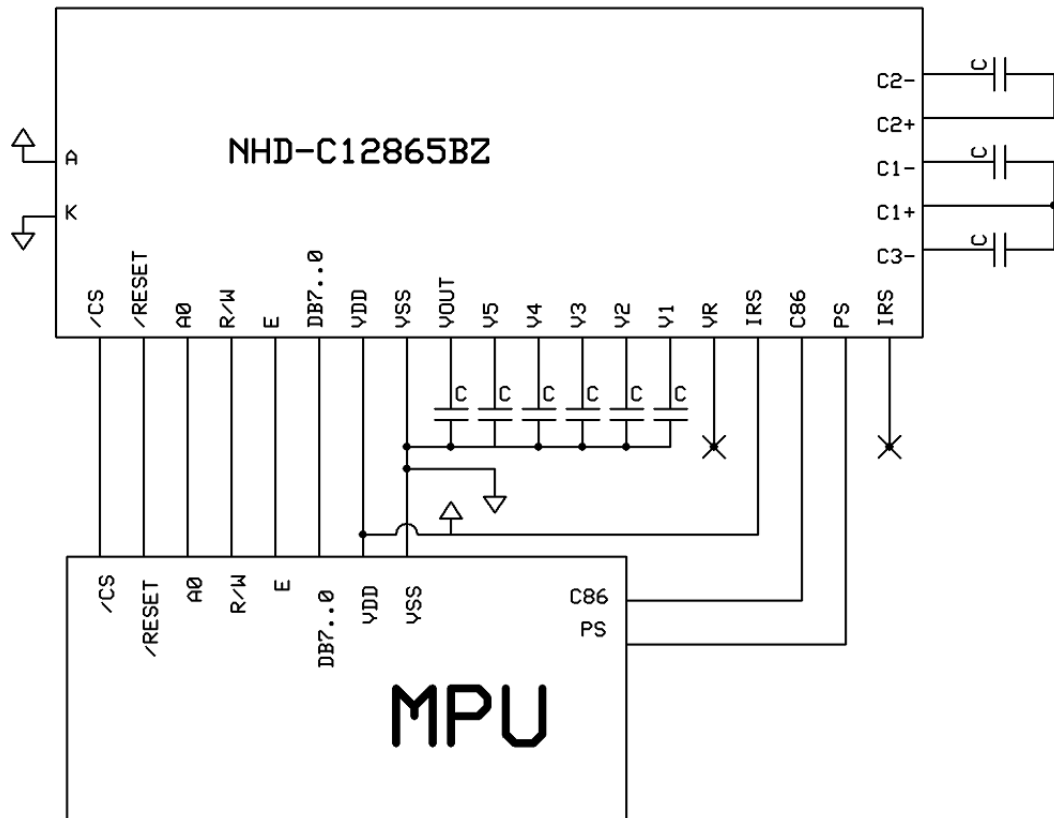

Electrical Characteristics

Item	Symbol	Condition	Min.	Typ.	Max.	Unit
Operating Temperature Range	Top	Absolute Max	-20	-	+70	°C
Storage Temperature Range	Tst	Absolute Max	-30	-	+80	°C
Supply Voltage	VDD		2.4	3.0	3.3	V
Supply Current	IDD	Ta=25°C, VDD=3.0V	-	1.5	2.5	mA
Supply for LCD (contrast)	VDD-V0	Ta=25°C	-	9.5	-	V
"H" Level input	Vih		2.2	-	VDD	V
"L" Level input	Vil		0	-	0.6	V
"H" Level output	Voh		2.4	-	-	V
"L" Level output	Vol		-	-	0.4	V

Optical Characteristics

Item	Symbol	Condition	Min.	Typ.	Max.	Unit
Viewing Angle - Vertical	θ	Cr≥2	-60	-	+35	°
Viewing Angle - Horizontal	Φ		-40	-	+40	°
Contrast Ratio	CR		-	6	-	-
Response Time (rise)	Tr	-	-	150	250	ms
Response Time (fall)	Tf	-	-	150	250	ms

Controller Information

Built-in SPLC501C. Download specification at http://www.newhavendisplay.com/app_notes/SPLC501C.pdf

Timing Characteristics

8.6.1. System bus read/write characteristics 1 (For the 8080 Series MPU)

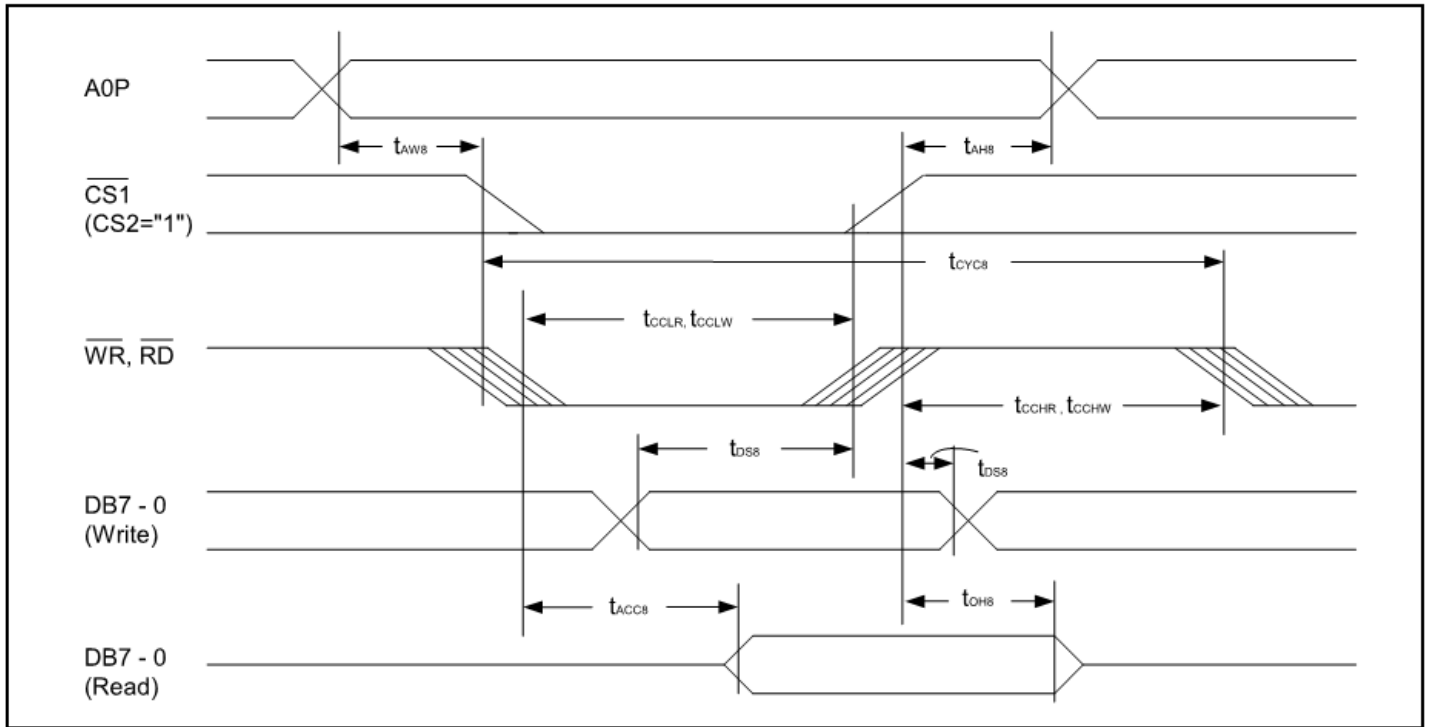

Item	Signal	Symbol	Condition	Rating		Units
				Min.	Max.	
Address hold time	A0P	t_{AH8}		0	-	ns
Address setup time	A0P	t_{AW8}		0	-	ns
System cycle time	A0P	t_{CYC8}		300	-	ns
Control L pulse width (WR)	WR	t_{CCLW}		60	-	ns
Control L pulse width (RD)	RD	t_{CCLR}		120	-	ns
Control H pulse width (WR)	WR	t_{CCHW}		60	-	ns
Control H pulse width (RD)	RD	t_{CCHR}		60	-	ns
Data setup time	DB7 - 0	t_{DS8}		40	-	ns
Address hold time		t_{DH8}		15	-	ns
RD access time		t_{ACC8}	$C_L = 100pF$	-	140	ns
Output disable time		t_{OH8}		10	100	ns

8.6.2. System bus read/write characteristics 2 (6800 series MPU)

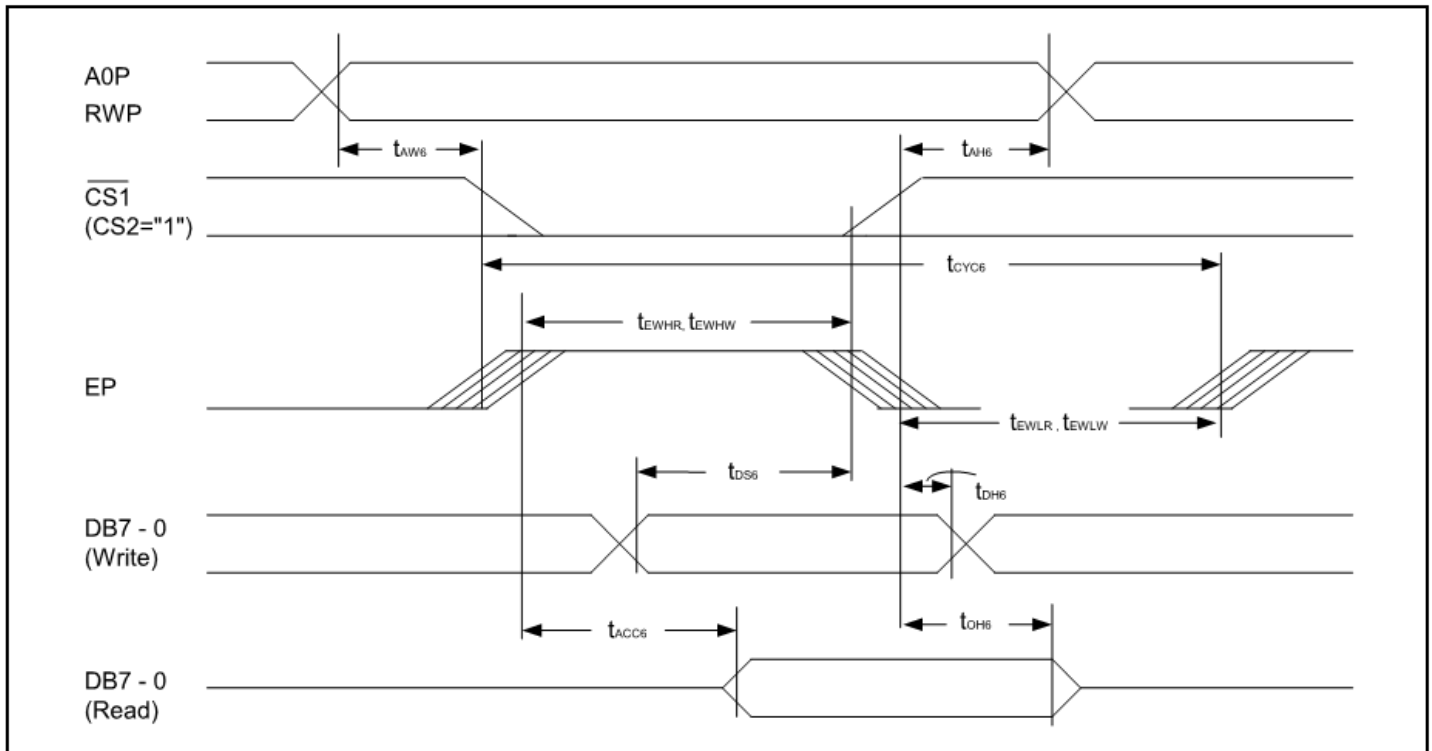

Item	Signal	Symbol	Condition	Rating		Units
				Min.	Max.	
Address hold time	A0P	t_{AH6}		0	-	ns
Address setup time	A0P	t_{AW6}		0	-	ns
System cycle time	A0P	t_{CYC6}		300	-	ns
Data setup time	DB7 - 0	t_{DS6}	$C_L = 100\text{pF}$	40	-	ns
Data hold time		t_{DH6}		15	-	ns
Access time	DB7 - 0	t_{ACC6}		-	140	ns
Output disable time		t_{OH6}		10	100	ns
Enable H pulse time	Read	EP	t_{EWHR}	120	-	ns
	Write		t_{EWHW}	60	-	ns
Enable L pulse time	Read	EP	t_{EWLR}	60	-	ns
	Write		t_{EWLW}	60	-	ns

8.6.3. The serial interface

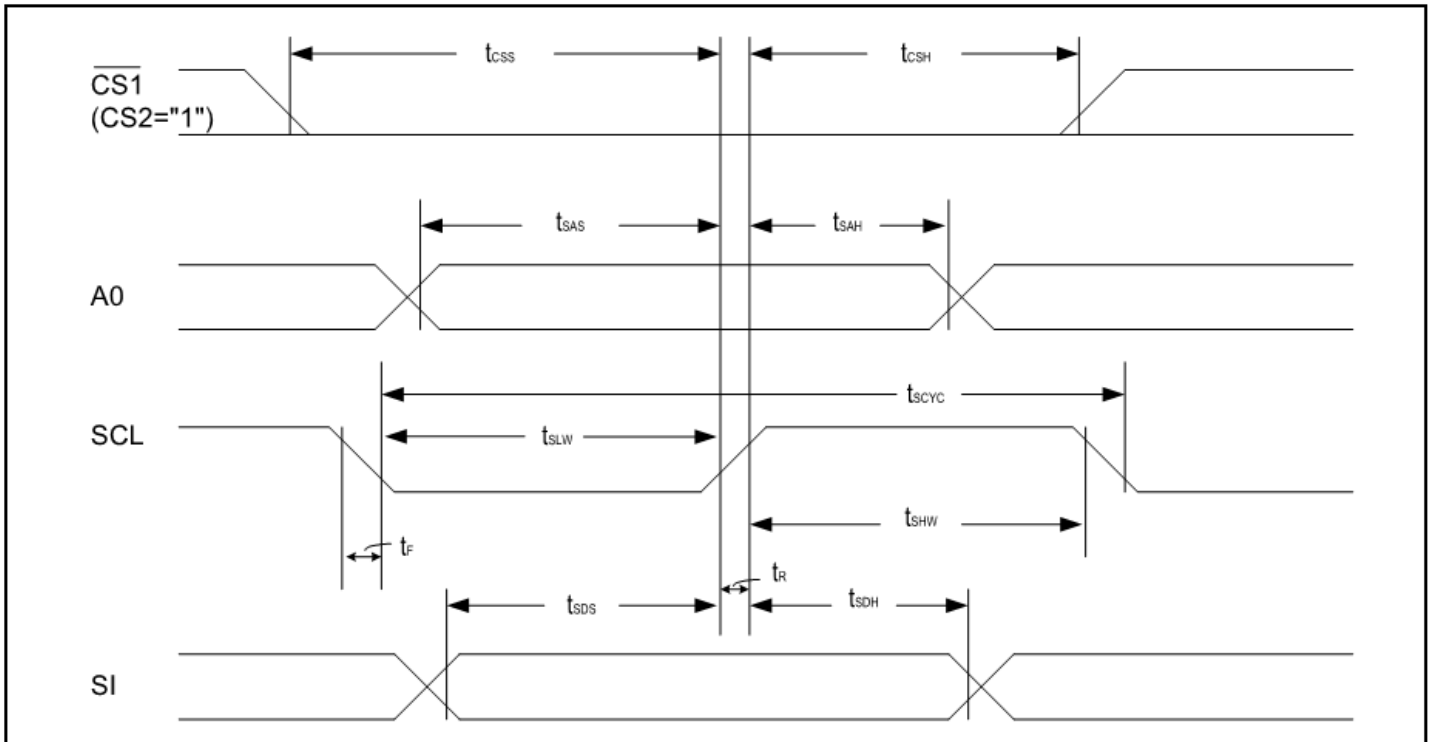

Item	Signal	Symbol	Condition	Rating		Units
				Min.	Max.	
Serial Clock Period		t_{SCYC}	-	250	-	ns
SCL 'H' pulse width	SCL	t_{SHW}	-	100	-	ns
SCL 'L' pulse width		t_{SLW}	-	100	-	ns
Address setup time	A0P	t_{SAS}	-	150	-	ns
Address hold time		t_{SAH}	-	150	-	ns
Data setup time	SI	t_{SDS}	-	100	-	ns
Data hold time		t_{SDH}	-	100	-	ns
CS-SCL time	CS	t_{CSS}	-	150	-	ns
		t_{CSH}	-	150	-	ns

Table of Commands

Command	Command Code											Function	
	A0P	RD	WR	DB7	DB6	DB5	DB4	DB3	DB2	DB1	DB0		
1). Display ON/OFF	0	1	0	1	0	1	0	1	1	1	0	LCD display ON/OFF 0: OFF, 1: ON	
2). Display start line set	0	1	0	0	1	Display start address					1	Sets the display RAM display start line address	
3). Page address set	0	1	0	1	0	1	1	Page address				1	Sets the display RAM page address
4). Column address set upper bit	0	1	0	0	0	0	1	Most significant column address				1	Sets the most significant 4 bits of the display RAM column address.
Column address set lower bit	0	1	0	0	0	0	0	Least significant column address				1	Set the least significant 4 bits of the display RAM column address.
5). Status read	0	0	1	Status				0	0	0	0	1	Reads the status data
6). Display data write	1	1	0	Write data								1	Writes to the display RAM
7). Display data read	1	0	1	Read data								1	Reads from the display RAM
8). ADC select	0	1	0	1	0	1	0	0	0	0	0	Sets the display RAM address SEG output correspondence 0: normal, 1:reverse	
9). Display normal/reverse	0	1	0	1	0	1	0	0	1	1	0	Sets the LCD display normal/ reverse 0: normal, 1:reverse	
10). Display all points ON/OFF	0	1	0	1	0	1	0	0	1	0	0	Display all points 0: normal display 1: all points ON	
11). LCD bias set	0	1	0	1	0	1	0	0	0	1	0	Sets the LCD driver voltage bias ratio SPLC501C.....0:1/9, 1:1/7	
12). Read/modify/write	0	1	0	1	1	1	0	0	0	0	0	Column address increment At write: +1 At read: 0	
13). End	0	1	0	1	1	1	0	1	1	1	0	Clear read/modify/write	
14). Reset	0	1	0	1	1	1	0	0	0	1	0	Internal reset	
15). Common output mode select	0	1	0	1	1	0	0	0	*	*	*	Select COM output scan direction 0: normal direction, 1: reverse direction	
16). Power control set	0	1	0	0	0	1	0	1	Operating mode			Select internal power supply operating mode	
17). V ₅ voltage regulator internal resistor ratio set	0	1	0	0	0	1	0	0	Resistor ratio			Select internal resistor ratio (Rb/Ra) mode	
18). Electronic volume mode set	0	1	0	1	0	0	0	0	0	0	1	Set the V ₅ output voltage electronic volume register	
Electronic volume register set	0	1	0	*	*	Electronic volume value							

Command	Command Code											Function
	A0P	RD	WR	DB7	DB6	DB5	DB4	DB3	DB2	DB1	DB0	
19). Static indicator ON/OFF	0	1	0	1	0	1	0	1	1	0	0	0: OFF, 1: ON
Static indicator Register set	0	1	0	*	*	*	*	*	*	Mode	1	Set the flashing mode
20). Page Blink	0	1	0	1	1	0	1	0	1	0	1	P7 - 0: 1 - blinking page 0 - no blinking, normal display
Page selection	0	1	0	P7	P6	P5	P4	P3	P2	P1	P0	
21). Driving Mode Set	0	1	0	1	1	0	1	0	0	1	0	Set the driving mode register
Mode selection	0	1	0	D1	D0	0	0	0	0	0	0	Driving capability (D1, D0): (1,1)>(0,0)>(0,1)>(1,0)
22). Power saver												Display OFF and display all points ON compound command
23). NOP	0	1	0	1	1	1	0	0	0	1	1	Command for non-operation
24). Test	0	1	0	1	1	1	1	*	*	*	*	Command for IC test. Do not use this command
				1	1	0	1	0	1	0	0	

Example Initialization Program

```
.....  
Sub Init  
Set P3.0  
Set P3.1  
Reset P3.4  
Set P3.3          'reset  
Reset P3.3  
Waitms 2  
Set P3.3  
Waitms 20  
A = &HA2          '1/9 BIAS  
Call Writecom  
A = &HA0          'ADC SELECT , NORMAL  
Call Writecom  
A = &HC8          'COM OUTPUT REVERSE  
Call Writecom  
A = &HA4          'DISPLAY ALL POINTS NORMAL  
Call Writecom  
A = &H40          'DISPLAY START LINE SET  
Call Writecom  
A = &H25          'INTERNAL RESISTOR RATIO  
Call Writecom  
A = &H81          'ELECTRONIC VOLUME MODE SET  
Call Writecom  
A = &H13          'ELECTRONIC VOLUME  
Call Writecom  
A = &H2F          'POWER CONTROLLER SET  
Call Writecom  
A = &HAF          'DISPLAY ON  
Call Writecom  
End Sub
```

```
.....  
Sub Writecom  
Reset P3.2        'A0  
Reset P3.1        'R/W  
Reset P3.4        'CS1  
Set P3.0          'E  
P1 = A  
Reset P3.0  
Set P3.4  
End Sub
```

```
.....  
Sub Writedata  
Set P3.2  
Reset P3.1  
Reset P3.4  
Set P3.0  
P1 = A  
Reset P3.0  
Set P3.4  
End Sub  
.....
```

Quality Information

Test Item	Content of Test	Test Condition	Note
High Temperature storage	Endurance test applying the high storage temperature for a long time.	+80°C , 48hrs	2
Low Temperature storage	Endurance test applying the low storage temperature for a long time.	-30°C , 48hrs	1,2
High Temperature Operation	Endurance test applying the electric stress (voltage & current) and the high thermal stress for a long time.	+70°C 48hrs	2
Low Temperature Operation	Endurance test applying the electric stress (voltage & current) and the low thermal stress for a long time.	-20°C , 48hrs	1,2
High Temperature / Humidity Operation	Endurance test applying the electric stress (voltage & current) and the high thermal with high humidity stress for a long time.	+40°C , 90% RH , 48hrs	1,2
Thermal Shock resistance	Endurance test applying the electric stress (voltage & current) during a cycle of low and high thermal stress.	-0°C,30min -> 25°C,5min -> 50°C,30min = 1 cycle 10 cycles	
Vibration test	Endurance test applying vibration to simulate transportation and use.	10-55Hz , 15mm amplitude. 60 sec in each of 3 directions X,Y,Z For 15 minutes	3
Static electricity test	Endurance test applying electric static discharge.	VS=800V, RS=1.5kΩ, CS=100pF One time	

Note 1: No condensation to be observed.

Note 2: Conducted after 4 hours of storage at 25°C, 0%RH.

Note 3: Test performed on product itself, not inside a container.

Precautions for using LCDs/LCMs

See Precautions at www.newhavendisplay.com/specs/precautions.pdf

Warranty Information and Terms & Conditions

http://www.newhavendisplay.com/index.php?main_page=terms