

NOTES:

1. MATERIALS AND FINISHES:
 - BODY - Be Cu, GOLD PLATING (.000050/.000070) THICK OVER ELECTROLESS NICKEL (.000050/.000070) THICK OVER (.000020/.000050) COPPER
 - BODY - Be Cu, GOLD PLATING (.000030 MIN THICK) OVER NICKEL (.000010 MIN)
 - COUPLING NUT - STAINLESS STEEL, PASSIVATED
 - CONTACT - Be Cu, GOLD PLATING (.000030 MIN THICK) OVER NICKEL (.000010 MIN)
2. ELECTRICAL:
 - A. IMPEDANCE: 50 OHM
 - B. FREQUENCY RANGE: DC - 18 GHz
 - C. VSWR: 1.020 +.002 X F IN GHZ MAX.
 - D. DIELECTRIC WITHSTANDING VOLTAGE: 1500 VRMS, MIN.
3. MECHANICAL:
 - A. TEMPERATURE RANGE: -65° C TO +85° C
4. PACKAGING:
 - A. QUANTITY: SINGLE PACK
 - B. MARKING: BAG TO BE MARKED "AMPHENOL, 131-91046, AND DATE CODE"

THIRD ANGLE PROJ.

REVISIONS

REV	DESCRIPTION	DATE	ECO	APPR
A	REL TO PROD	--	--	--
H	REDRAWN IN PRO-E	1/26/09	47233	CL
J	CHANGED PLATING CODE ON ITEM 5 FROM YA TO JE	7/21/11	48662	MJS
K	BODY CHANGED PLATING FROM SULPHAMATE NICKEL TO ELECTROLESS NICKEL	10/16/12	49268	CL

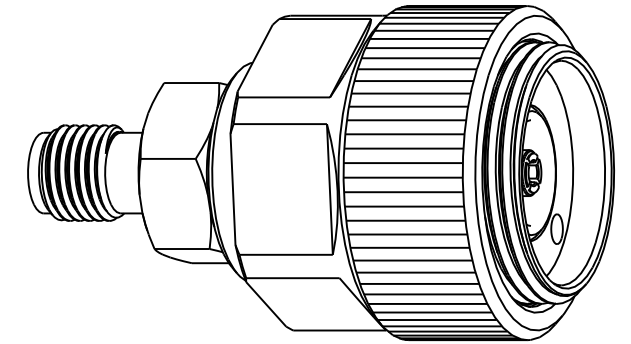

SCALE 2.000

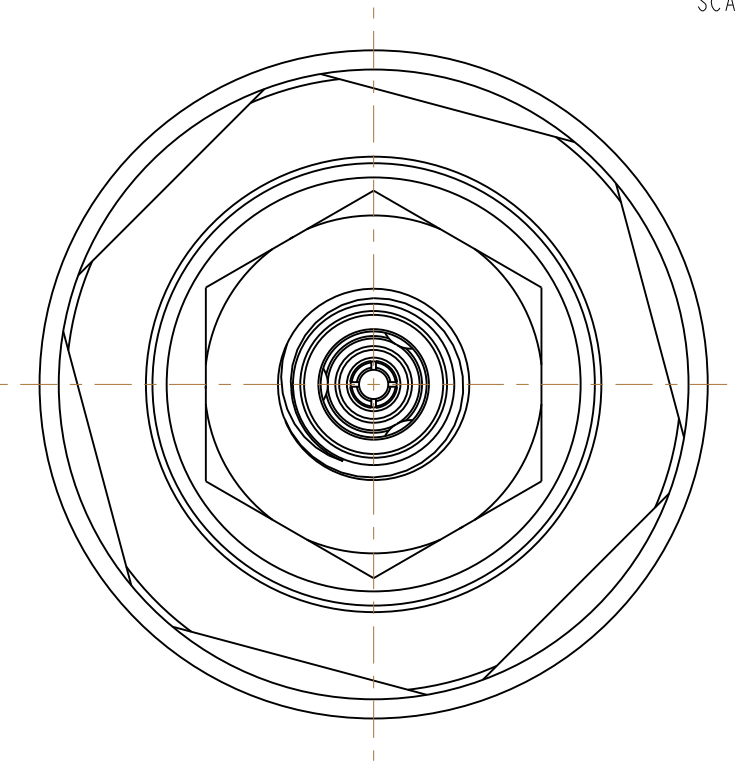
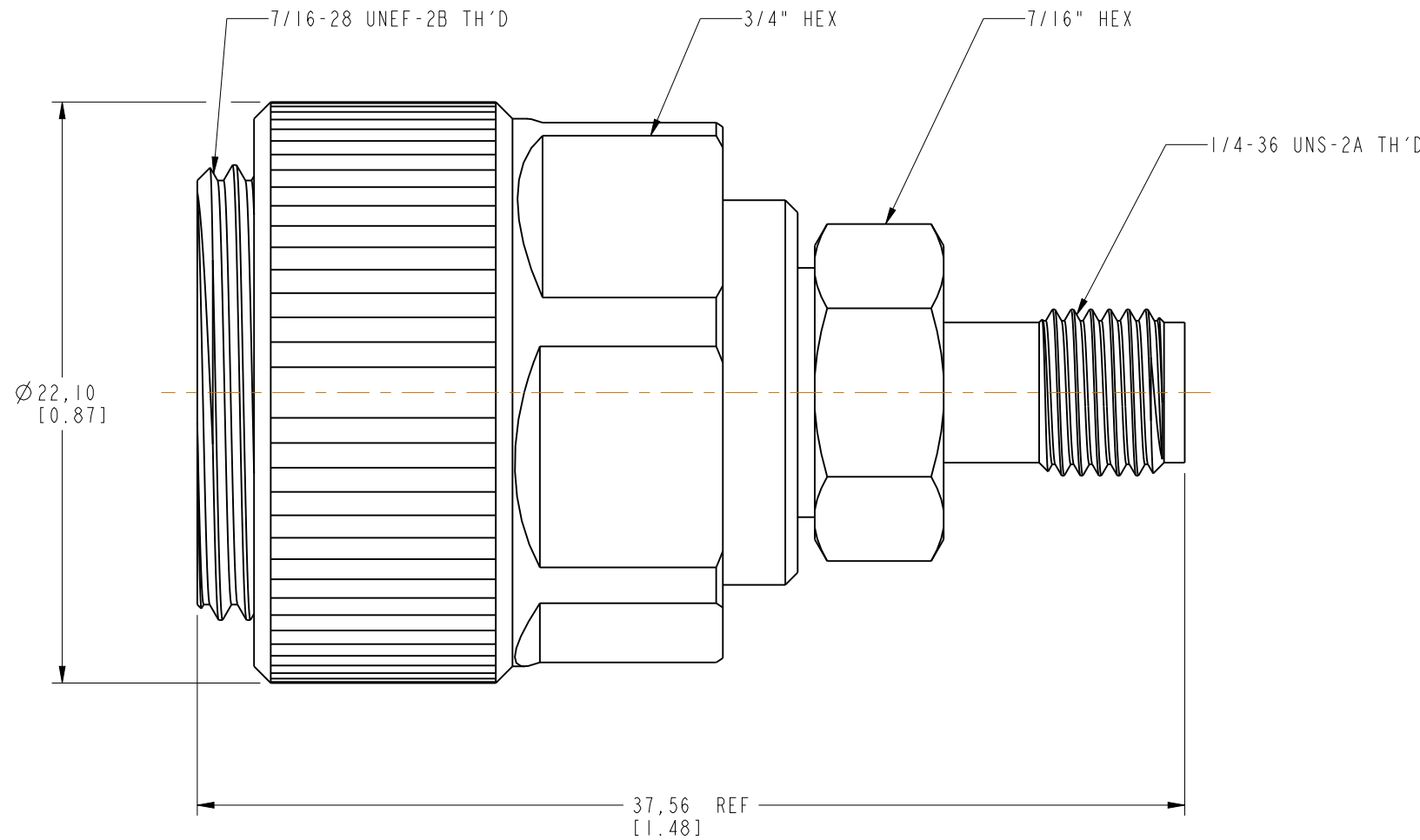

CUSTOMER OUTLINE DRAWING

ALL OTHER SHEETS ARE FOR INTERNAL USE ONLY

UNLESS OTHERWISE SPECIFIED, DIMENSIONS ARE IN METRIC AND TOLERANCES ARE: 0.5 - 6mm ±0.1mm 6 - 30mm ±0.2mm 30 - 120mm ±0.3mm ANGLES ±1°	MATERIAL	DRAWN CLEMENT	DATE 20-AUG-08	TITLE APC-7 TO 3.5MM FEMALE ADAPTOR		Amphenol RF Danbury CT USA, Tainan, Taiwan, Shenzhen, China www.amphenolrf.com	
	REFERENCE EAR # AND	ENGINEER CLEMENT	DATE 20-AUG-08				
NOTICE - These drawings, specifications, or other data (1) are, and remain the property of Amphenol corp. (2) must be returned upon request; and (3) are confidential and not to be disclosed to any person other than those to whom they are given by Amphenol Corp. the furnishing of these drawings, specifications, or other data by Amphenol Corp., or to any other person to anyone for any purpose is not to be regarded by implication or otherwise in any manner licensing, granting rights to permitting such holder or any other sperson to manufacture, use or sell any product, process or design, patented or otherwise, that may in any way be related to or disclosed by said drawings, specifications, or other data.	CONFIGURATION LEVEL:	APPROVED K. CAPOZZI	DATE 1/23/09	SCALE: 4.0:1.0	SHEET 2 OF 2	ITEM NO.131-91046	
	FINISH	CAD FILE Root Folder/APC-7/131-91046	DWG SIZE B	CODE ID 74868	REV K	PART NO.131-91046	