

THIS DRAWING IS UNPUBLISHED. RELEASED FOR PUBLICATION  
 © COPYRIGHT copyright.d8te- ALL RIGHTS RESERVED.

REVISIONS				
P	LTR	DESCRIPTION	DATE	APVD
	A	FIRST RELEASED	20DEC2017	J. J. W. H.

# 2306334-3 AS SHOWN

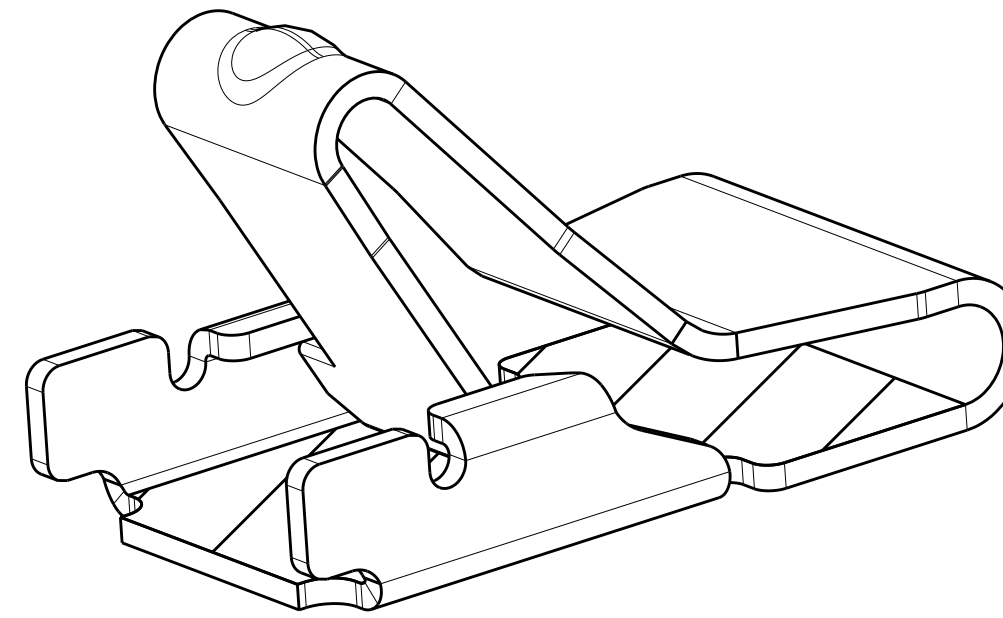
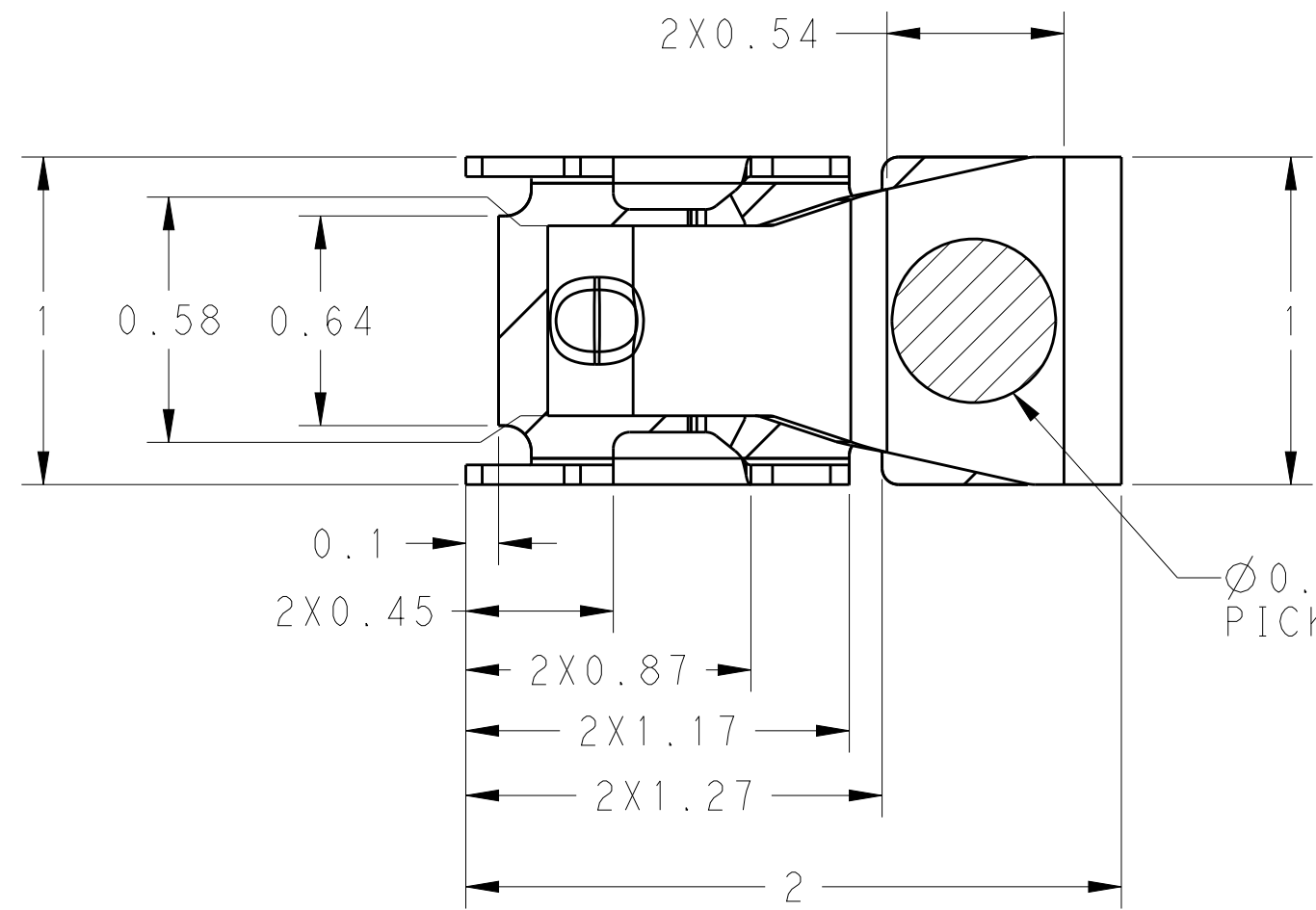

SCALE 60:1

NOTE:

① MATERIAL: STAINLESS STEEL, TEMPER: K1500, THK: 0.06 mm

② FINISH: NICKEL PLATING 0.002~0.003 mm OVER ALL, GOLD PLATING 0.0001 mm AT CONTACT AREA, GOLDP LATING 0.000025 mm AT SOLDDERING AREA.

3 WORKING POSITION: 0.7±0.2 mm.

Ø0.5 PICK & PLACE AREA

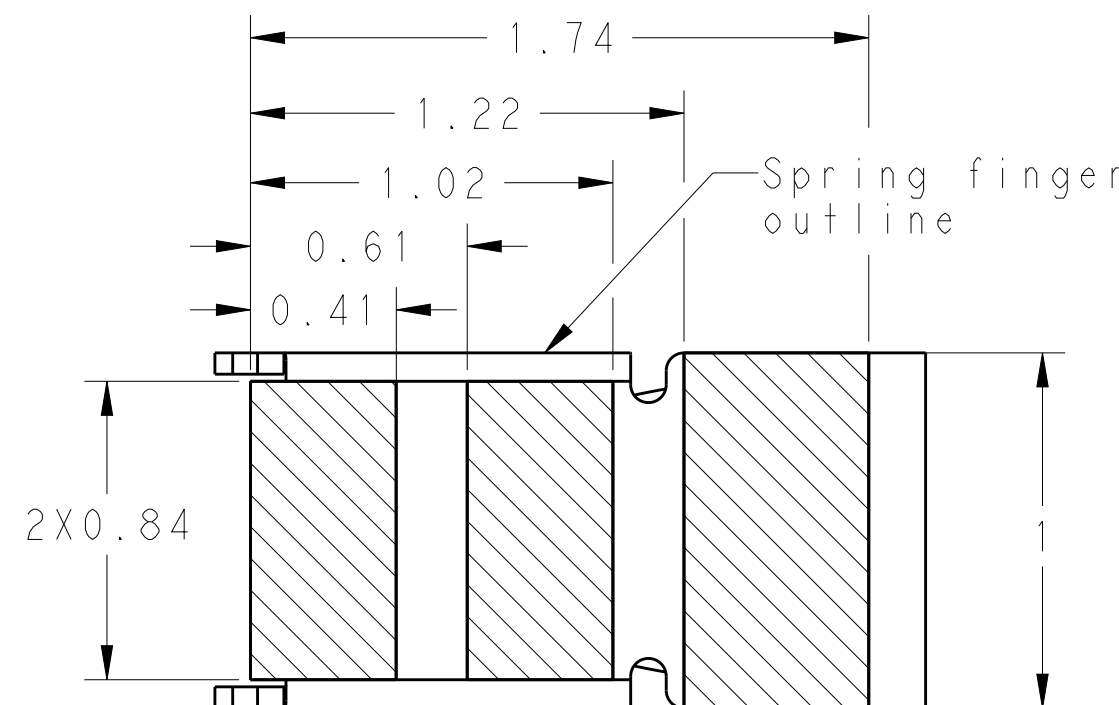
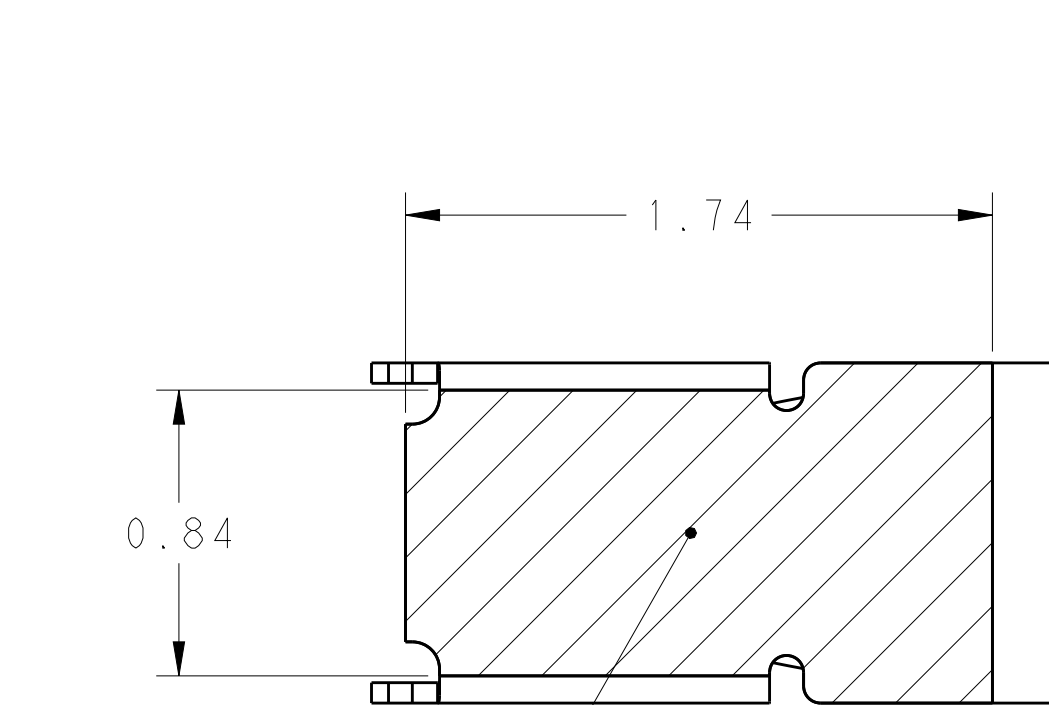
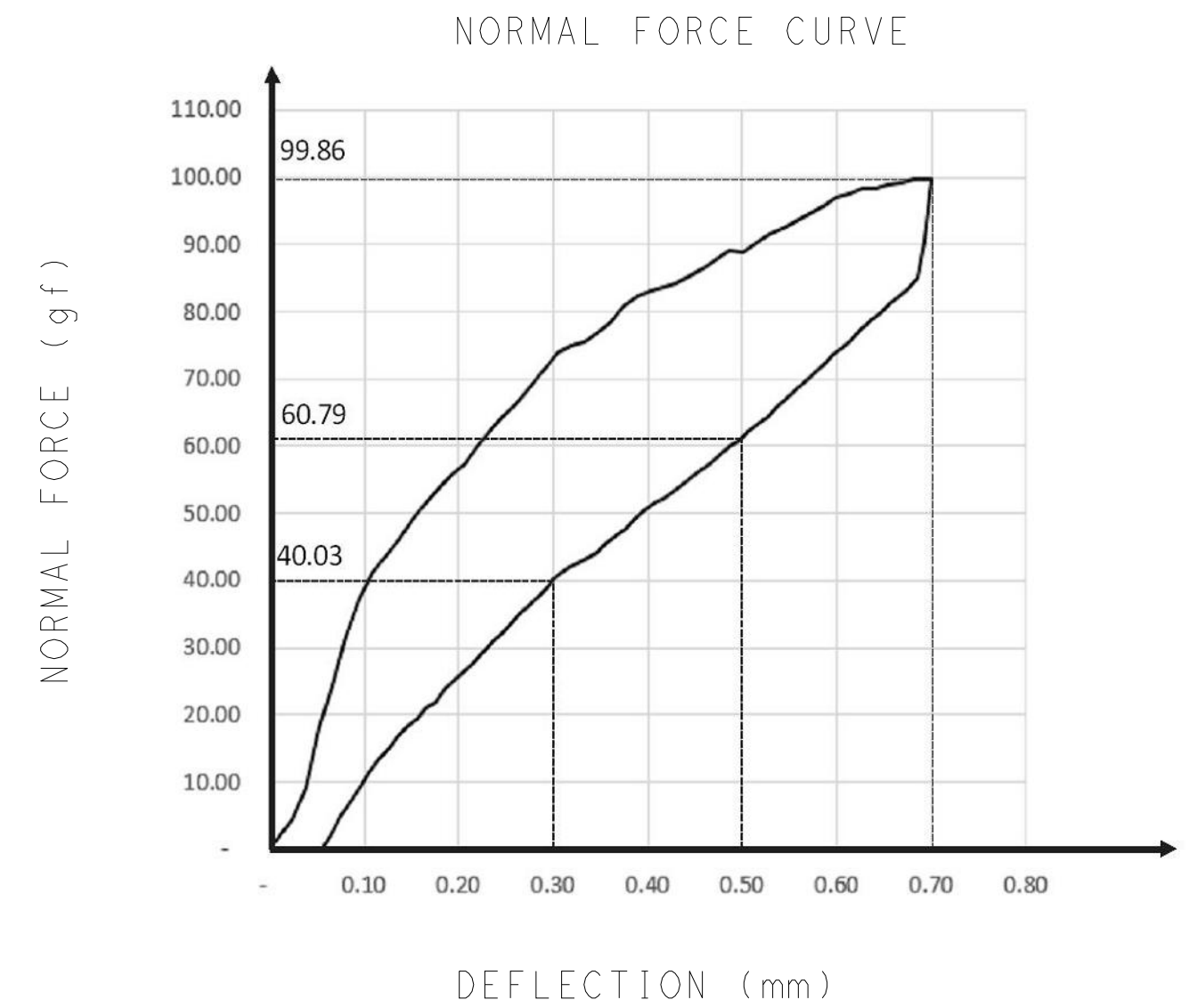
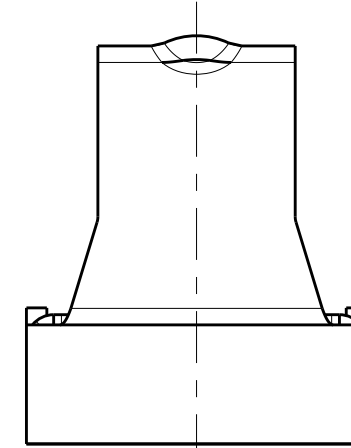
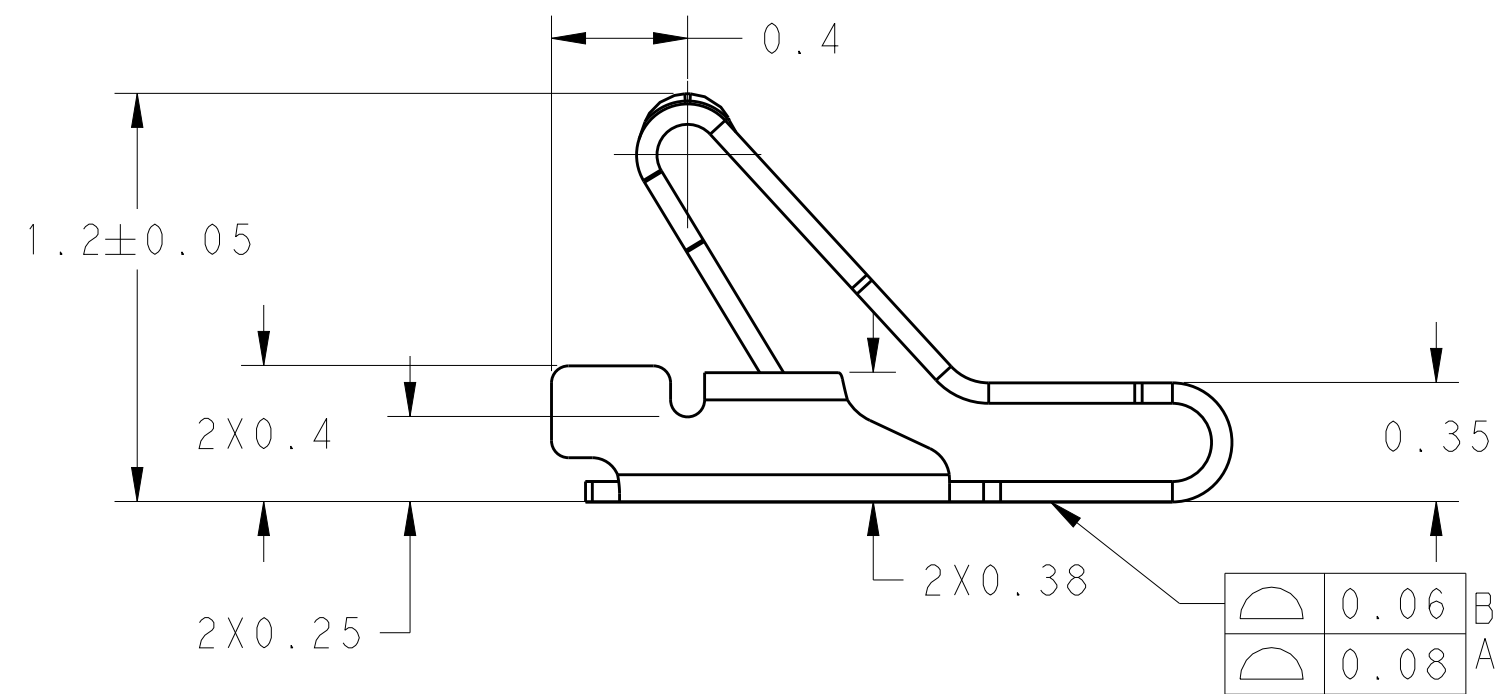

SCALE: 45:1  
 RECOMMENDED PCB LAYOUT  
 TOL: ±0.02

THIS DRAWING IS A CONTROLLED DOCUMENT.		DWN SIMON WU 4JUL2016	TE Connectivity	
DIMENSIONS: mm		CHK WENKE HE 4JUL2016		
TOLERANCES UNLESS OTHERWISE SPECIFIED:		APVD WENKE HE 4JUL2016	NAME	
0-PLC ±0.1		PRODUCT SPEC		
1-PLC ±0.1		APPLICATION SPEC		
2-PLC ±0.01		WEIGHT 0.0024		
3-PLC ±0.001		SIZE A2		
4-PLC ±0.0001		CAGE CODE -		
ANGLES ±3°		DRAWING NO C-2306334		
FINISH -		RESTRICTED TO		
MATERIAL -		SCALE 48:1 SHEET 1 OF 2 REV A		
-		CUSTOMER DRAWING		

THIS DRAWING IS UNPUBLISHED. RELEASED FOR PUBLICATION  
 © COPYRIGHT copyright.d8te- ALL RIGHTS RESERVED.

REVISIONS				
P	LTR	DESCRIPTION	DATE	APVD
-	-	SEE SHEET 1	-	-

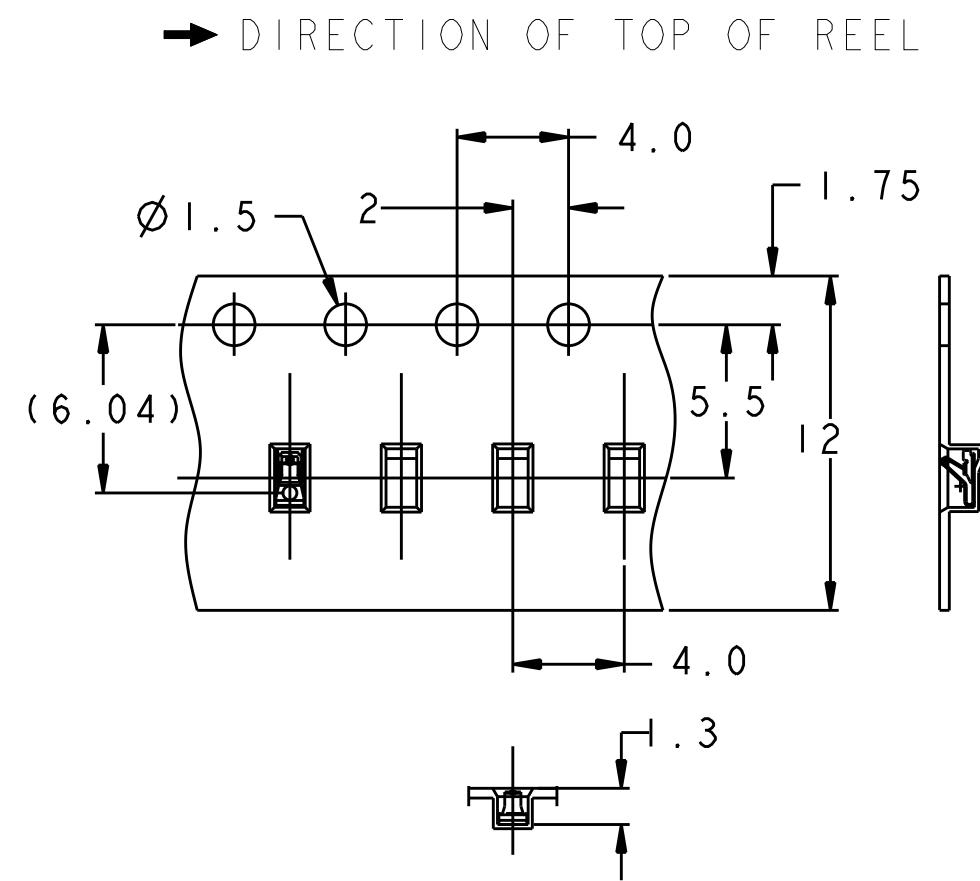
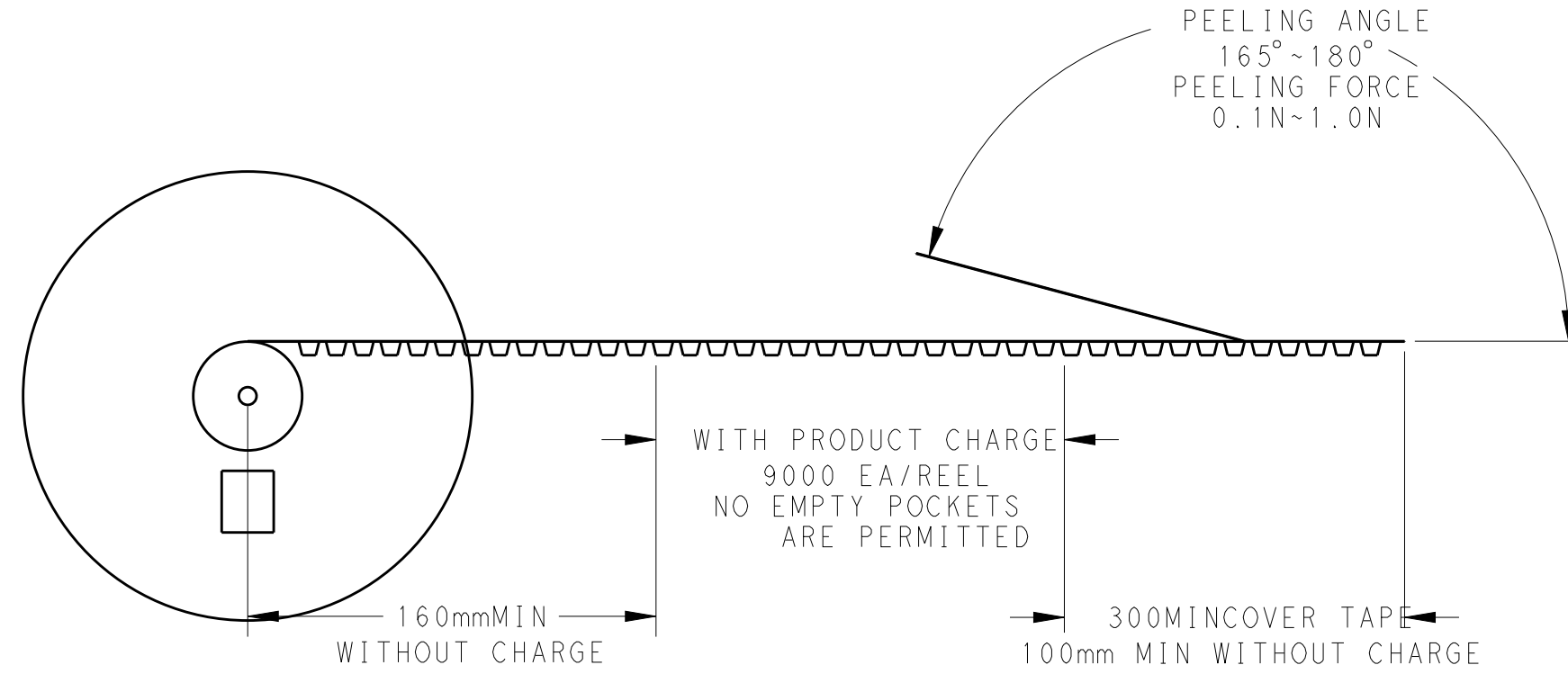
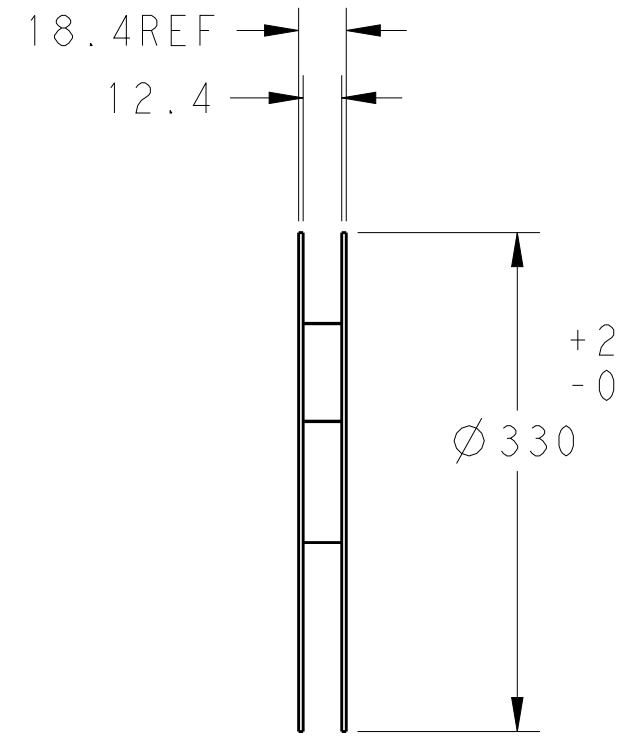

PACKAGE FOR REFERENCE

THIS DRAWING IS A CONTROLLED DOCUMENT.		DWN SIMON WU 4 JUL 2016	TE Connectivity	
DIMENSIONS: mm		CHK WENKE HE 4 JUL 2016		
TOLERANCES UNLESS OTHERWISE SPECIFIED: 0-PLC ±0.2 1-PLC ±0.1 2-PLC ±0.01 3-PLC ±0.001 4-PLC ±0.0001		APVD WENKE HE 4 JUL 2016	NAME 1.2H SPRING FINGER	
MATERIAL - -		PRODUCT SPEC -	SIZE A2	CAGE CODE -
FINISH - -		APPLICATION SPEC -	DRAWING NO G-2306334	RESTRICTED TO
CUSTOMER DRAWING		WEIGHT 0.0024	SCALE 1:1	SHEET 2 OF 2
			REV A	