

THIS DRAWING IS UNPUBLISHED. RELEASED FOR PUBLICATION
 © COPYRIGHT - By - ALL RIGHTS RESERVED.

REVISIONS				
P	LTR	DESCRIPTION	DATE	APVD
T2		REVISED PER ECO-16-004223	21JUL2016	NK MZ

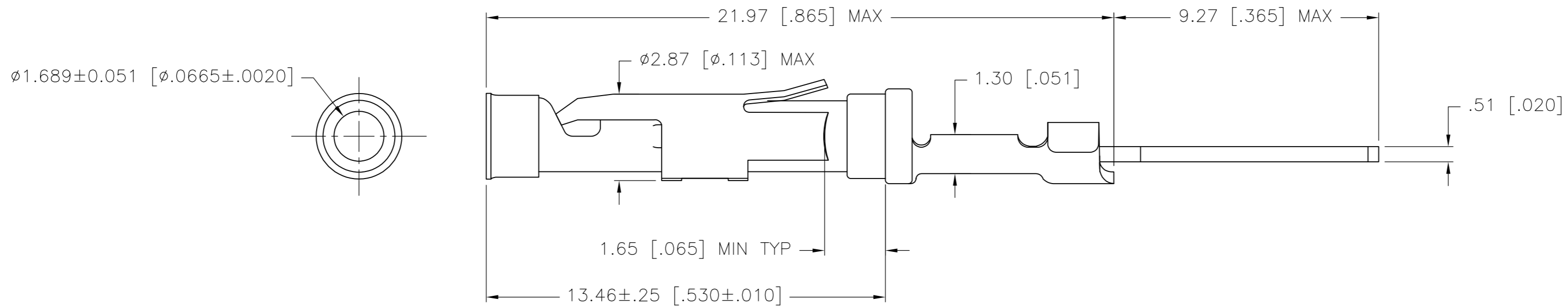
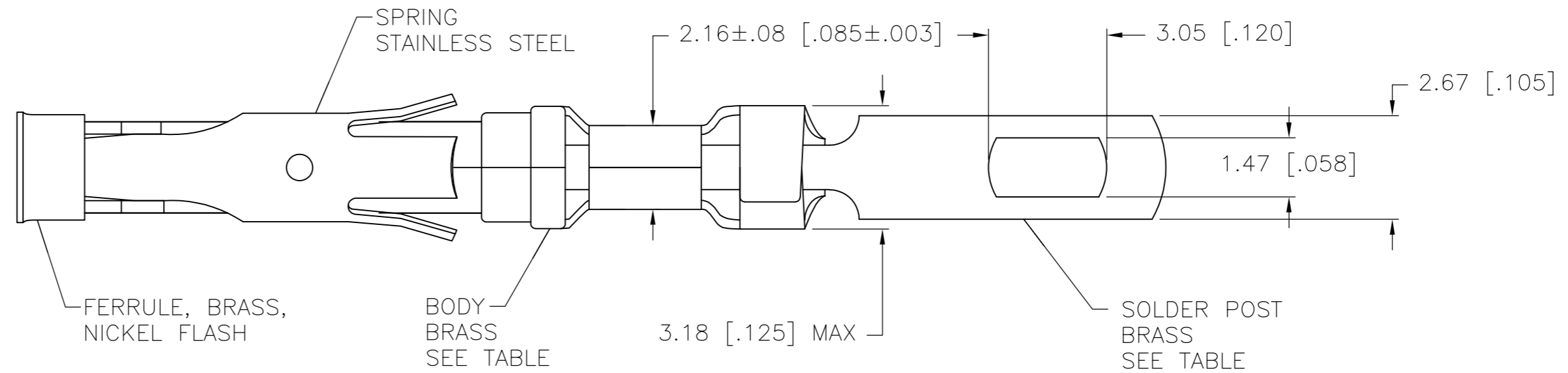

- 1 0.76 μm [.000030] MIN GOLD PER MIL-G-45204 ON MATING END FOR A LENGTH OF 5.08 [.200] MIN WITH A UNIFORM GRADIENT TO 0.25 μm [.000010] MIN GOLD PER MIL-G-45204 ON THE REMAINDER OVER 0.76 μm [.000030] MIN NICKEL PER QQ-N-290.
- 2 1.27 μm [.000050] MIN TIN-LEAD PER MIL-T-10727 OVER 0.76 μm [.000030] MIN NICKEL PER QQ-N-290.
- 3 2.54 μm [.000100] MIN TIN-LEAD PER MIL-T-10727 OVER 1.27 μm [.000050] MIN NICKEL PER QQ-N-290.
- 4 2.54 μm [.000100] MIN TIN PER MIL-T-10727 OVER 1.27 μm [.000050] MIN NICKEL PER QQ-N-290.
- 5 1.27 μm [.000050] MIN TIN PER MIL-T-10727 OVER 0.76 μm [.000030] MIN NICKEL PER QQ-N-290.

	SMALL PACK	4	1	202237-8
	STANDARD	4	1	202237-7
OBSOLETE	SMALL PACK	4	5	202237-6
	STANDARD	4	5	202237-5
	SMALL PACK	3	2	202237-4
	SMALL PACK	3	1	202237-3
	STANDARD	3	2	202237-2
	STANDARD	3	1	202237-1
	PACKAGING TYPE	SOLDER POST FINISH	BODY FINISH	PART NO

THIS DRAWING IS A CONTROLLED DOCUMENT.

DWN	R.SHIREY	31JUL91
CHK	R.STONE	20SEP91
APVD	J. WESTMAN	20SEP91
PRODUCT SPEC	-	
APPLICATION SPEC	-	
WEIGHT	-	
CUSTOMER DRAWING	SCALE	8:1

TE Connectivity

SOCKET ASSEMBLY, SOLDER POST, TYPE III+

SIZE: A2 CAGE CODE: 00779 DRAWING NO: 202237 RESTRICTED TO: -

SHEET 1 OF 1 REV T2