

## 700 / 800 / 900MHz 0.5 WATT BROADBAND CMOS RFEIC

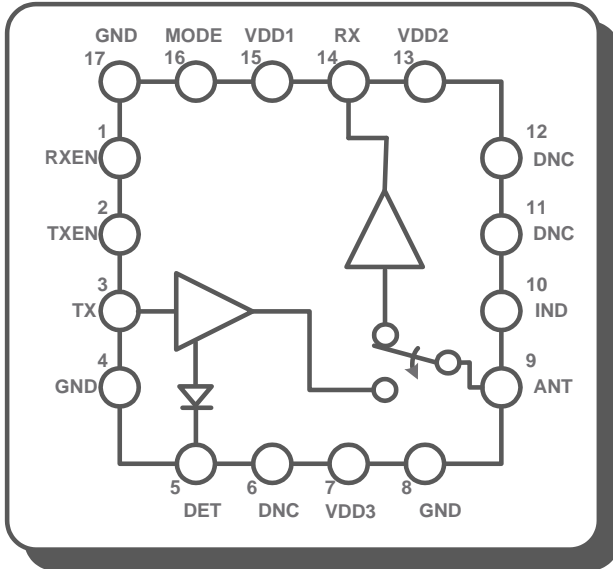

### Description

The RFX1010 is a broadband, fully integrated, single-chip, single-die RFEIC (RF Front-end Integrated Circuit) which incorporates all the RF functionality needed for a TDD-mode RF front-end operated in the 700/800/900MHz frequency bands.

The RFX1010 architecture integrates a linear PA, LNA, Transmit and Receive switching circuitry, associated matching networks, and harmonic filters all in a CMOS single-chip device. The RFX1010 requires minimal external components including the power supply bypass capacitors.

This RFEIC is designed for medium to high output power, and consumes low current in receive mode. The combination of superior output power, high sensitivity and efficiency, low noise, small form factor and low cost makes RFX1010 the ideal solution for multiple applications including IEEE 802.15.4, ZigBee, AMR, Smart Home Area Network and other ISM applications in the sub-GHz bands from 780 to 960MHz. It can also be used for IEEE 802.11p and 802.11ah.

### Features

- ▶ 700/800/900MHz Single-Chip, Single-Die RF Front-End IC
- ▶ Separate TX and RX RF Transceiver Ports and Single Antenna Port
- ▶ 700/800/900MHz Power Amplifier with Low-Pass Harmonic Filters
- ▶ Low Noise Amplifier
- ▶ Transmit/Receive Switch Circuitry
- ▶ High Transmit Signal Linearity Meeting Standards for OQPSK Modulation
- ▶ Low Voltage (1.2V) CMOS Control Logic
- ▶ ESD Protection Circuitry on All Pins DC Grounded RF Ports
- ▶ Internal RF Decoupling on All VDD Bias Pins
- ▶ Low Noise Figure for the Receive Channel
- ▶ High Power Handling Capability for Received Signals
- ▶ Very Low DC Power Consumption
- ▶ Full On-chip Matching and Decoupling Circuitry
- ▶ Minimal External Components Required
- ▶ 50-Ohm Input / Output Matching
- ▶ Market Proven Low Cost CMOS Technology
- ▶ 3 x 3 x 0.55mm Small Outline QFN-16 Package with Exposed Ground Pad

### Applications

- ▶ N. America 900MHz ISM Systems
- ▶ E Europe 870MHz SRD Systems
- ▶ Smart Grid/AMR/AMI
- ▶ Smart Home Appliances
- ▶ Remote Sensor and Control
- ▶ Other 700/800/900MHz Radios

**PIN ASSIGNMENTS:**

Pin Number	Pin Name	Description
1	RXEN	CMOS Input to Enable Receive Mode
2	TXEN	CMOS Input to Enable Transmit Mode
3	TX	RF TX Signal from the Transceiver to the PA: DC Shorted to GND
5	DET	Analog Voltage Proportional to the PA Power Output
4, 8, 17	GND	Ground – Must Be Connected to Ground in the Application Circuit
7	VDD3	Voltage Supply Connection for the Power Stage of PA
9	ANT	Common RF Port Connected to the Antenna, DC Shorted to GND
10	IND	Port for Connecting ANT Matching Inductor
6, 11, 12	DNC	Do Not Connect – Must be left floating in the Application Circuit
13	VDD2	Voltage Supply Connection for the LNA
14	RX	RF RX Signal from the LNA to the Transceiver, DC Shorted to GND
15	VDD1	Voltage Supply Connection for the Driver Stage of PA
16	MODE	CMOS Input to Control High Gain/Low Gain for RX

**PIN-OUT DIAGRAM:**

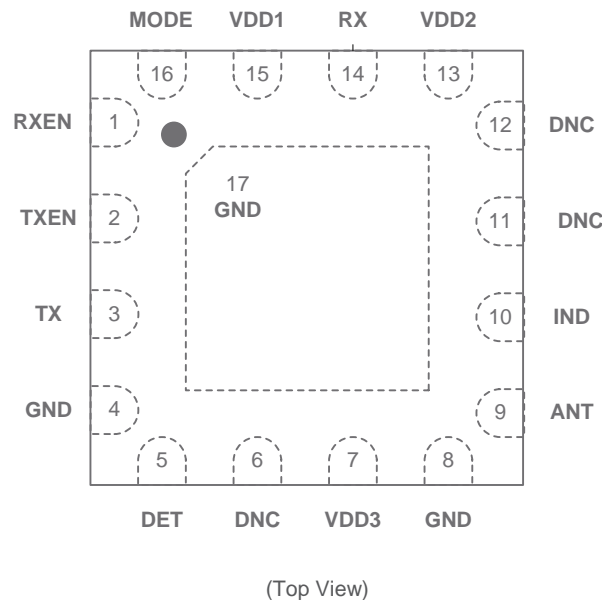

**ABSOLUTE MAXIMUM RATINGS:**

Parameters	Units	Min	Max	Conditions
DC VDD Voltage Supply	V	0	4.2	All VDD Pins
DC Control Pin Voltage	V	0	3.6	
TX RF Input Power	dBm		+7	
ANT RF Input Power	dBm		+5	When RX is "ON"
Junction Temperature	°C		+150	
Storage Ambient Temperature	°C	-50	+150	No RF and DC Voltages Applied Appropriate care required according to JEDEC Standards

*Note: Sustained operation at or above the Absolute Maximum Ratings for any one or combinations of the above parameters may result in permanent damage to the device and is not recommended. All Maximum RF Input Power Ratings assume 50-Ohm terminal impedance.*

**RECOMENDED OPERATING CONDITIONS:**

Parameters	Units	Min	Typ	Max	Conditions
DC VDD Voltage Supply (Note 1)	V	2.7	3.3	3.6	All VDD Pins
Control Voltage "High"	V	1.2		VDD	RXEN, TXEN, and MODE Pins
Control Voltage "Low"	V			0.3	RXEN, TXEN, and MODE Pins
Operating Ambient Temperature	°C	-40		+125	See note 2
$\theta_{ja}$	°C/W		38		

*Note 1 – For normal operation of the RFX1010, VDD must be continuously applied to all VDD supply pins.*

*Note2 – For operation above +85 °C, use the  $\theta_{ja}$  as guidance for system design to assure the junction temperature will not exceed the maximum of +150 °C.*

**DC Characteristics (VDD=3.3V; T=+25 °C)**

Parameters	Units	Min	Typ	Max	Conditions
DC Control Pin Current Consumption	µA		0.1		RXEN, TXEN, and MODE Pins
DC Shutdown Current	µA		1		
Transmit-Receive Switching Time	usec			1	
Shut-Down and "ON" State Switching Time	usec			1	

TRANSMIT TECHNICAL PARAMETERS (VDD=3.3V; T=+25 °C)

Parameters	Units	Min	Typ	Max	Conditions
Operating Frequency Band <sup>NOTE1</sup>	MHz	780		960	All RF Pins Loaded by 50-Ohms
Saturated Output Power	dBm	+26	+27		In Band
Linear Output Power	dBm		16		For 3% EVM, 802.11ah, 4MHz/64QAM
Large Signal Gain	dB		28		P <sub>OUT</sub> = +27dBm
Large Signal Current	mA		350		P <sub>OUT</sub> = +27dBm, Burst, 10% Duty Cycle
Quiescent Current	mA		40		
Second Harmonic	dBc		-32		P <sub>OUT</sub> = +27dBm
Third Harmonic	dBc		-22		P <sub>OUT</sub> = +27dBm
Input Return Loss (S11)	dB		-10		
Input/Output Impedance Single-Ended	Ohm		50		
Power Detector Voltage	mV	200		1800	Pout = +5 to +27dBm, 10kΩ load
VSWR for stability			6:1		For all non-harmonic related spurs below -42dBm/MHz, P <sub>IN</sub> fixed for P <sub>OUT</sub> =+27dBm with 50ohm load
VSWR for ruggedness			10:1		No damage, Pin <= +5dBm

Note 1: Matching component will vary for different frequency bands

RECEIVE TECHNICAL PARAMETERS (VDD=3.3V; T=+25 °C)

Parameters	Units	Min	Typ	Max	Conditions
Operating Frequency Band	MHz	780		960	All RF Pins are Loaded by 50-Ohm
Gain	dB		14		High Gain Mode
			12		Low Gain Mode
Noise Figure	dB		3		High Gain Mode
			3.5		Low Gain Mode
Input Return Loss (S11)	dB		-10		At ANT Pin
Output Return Loss (S22)	dB		-10		At RX Pin
RF Port Impedance	Ohm		50		At RX and ANT Pins
DC Current	mA		16		P <sub>OUT</sub> < -10dBm, High Gain Mode
DC Current	mA		10		P <sub>OUT</sub> < -10dBm, Low Gain Mode
Input P <sub>1dB</sub>	dBm		-5		High Gain Mode
			-5		Low Gain Mode

CONTROL SIGNAL DIAGRAM

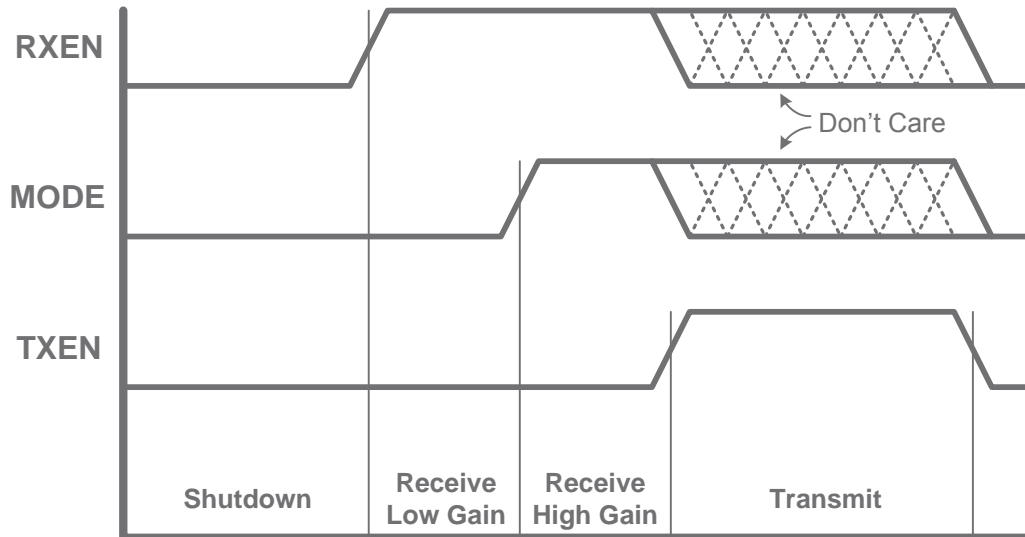

CONTROL LOGIC TRUTH TABLE

TXON	RXON	MODE	Operating Conditions
0	0	X	Shut-down
0	1	0	RX Active, Low Gain Mode
0	1	1	RX Active, High Gain Mode
1	X	X	TX Active

Note: "1" denotes high voltage state (> 1.2V)  
 "0" denotes low voltage stage (<0.3V) at Control Pins  
 "X" denotes the don't care state (Floating control pins is not allowed)

PACKAGE DIMENSIONS

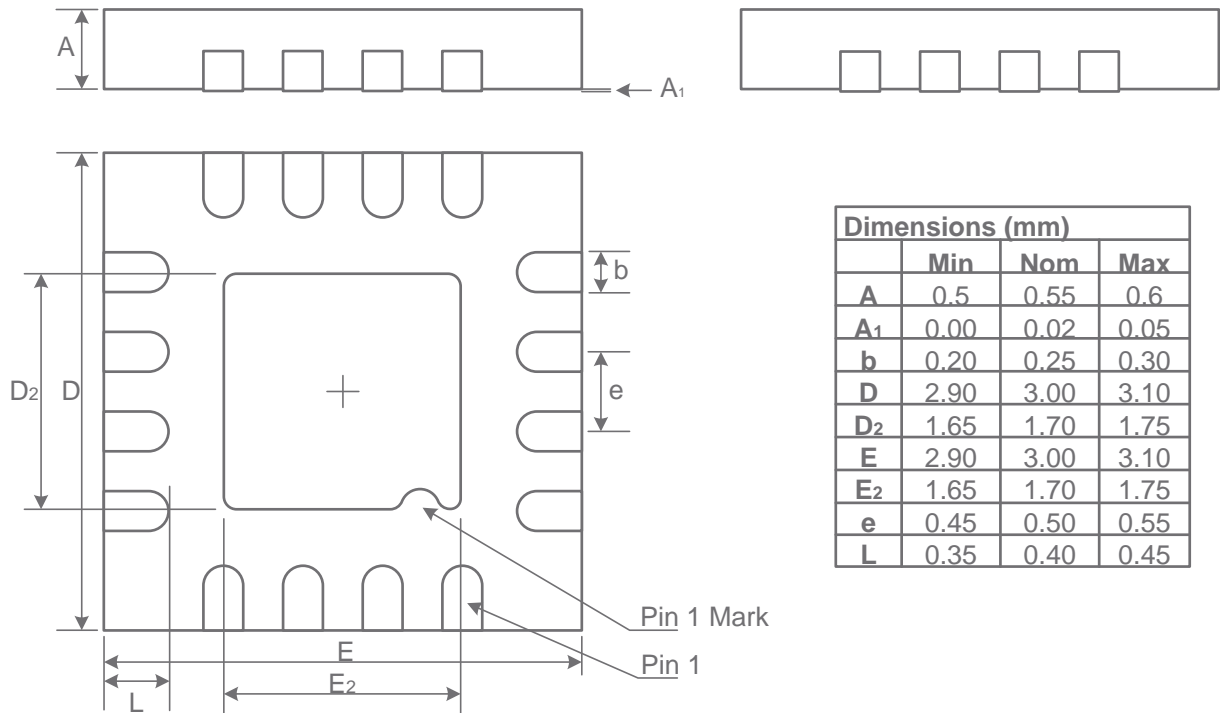

Dimensions (mm)			
	Min	Nom	Max
<b>A</b>	0.5	0.55	0.6
<b>A<sub>1</sub></b>	0.00	0.02	0.05
<b>b</b>	0.20	0.25	0.30
<b>D</b>	2.90	3.00	3.10
<b>D<sub>2</sub></b>	1.65	1.70	1.75
<b>E</b>	2.90	3.00	3.10
<b>E<sub>2</sub></b>	1.65	1.70	1.75
<b>e</b>	0.45	0.50	0.55
<b>L</b>	0.35	0.40	0.45

PACKAGE MARKING

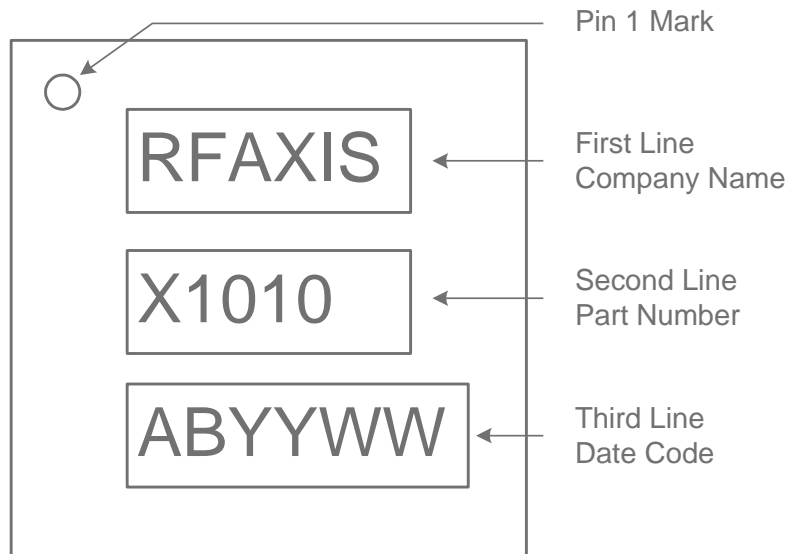

TAPE AND REEL INFORMATION:

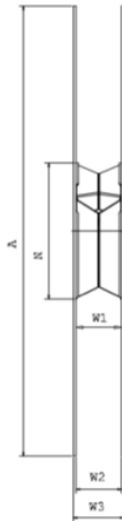
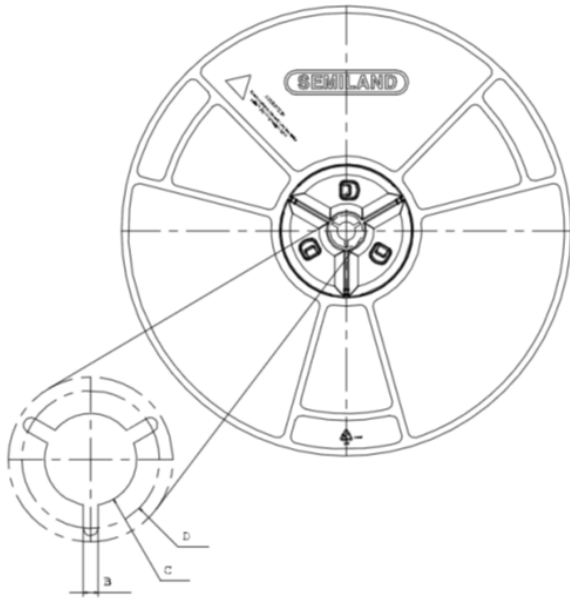
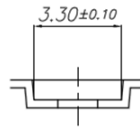
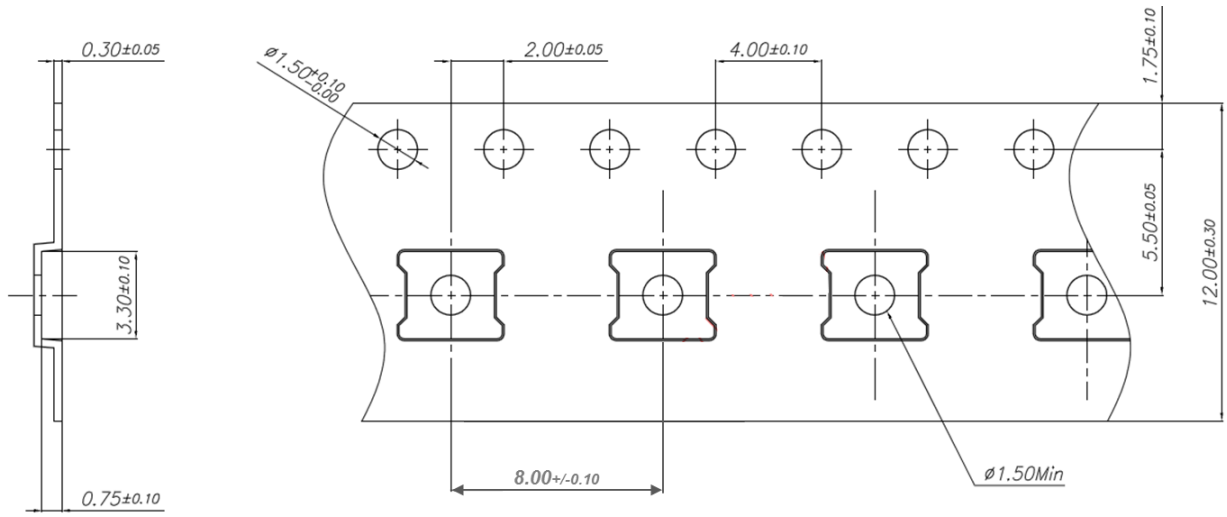

Size	12mm
A	330 <sup>+0.2</sup> <sub>-2.0</sub>
B	1.5min
C	13.0 <sup>+0.5</sup> <sub>-0.2</sub>
D	20.2min
N	100 <sup>+2.0</sup> <sub>-0.0</sub>
W1	12.4 <sup>+3.0</sup> <sub>-0.0</sub>
W2	12.4 <sup>+3.0</sup> <sub>-0.0</sub>
W3	16.4 <sup>+2.0</sup> <sub>-2.0</sub>
PART#	SRL-12134H