

THIS DRAWING IS UNPUBLISHED. RELEASED FOR PUBLICATION 20
 © COPYRIGHT 20 BY - ALL RIGHTS RESERVED.

LOC	DIST	REVISIONS					
		P	LTR	DESCRIPTION	DATE	DWN	APVD
-	-	A		RELEASE	02APR2015	M.S	X.X
		AI		UPDATE TABLE	16APR2015	M.S	X.X
		B		ECR-16-015004	25OCT2016	M.S	X.X
		BI		ECR-17-000249	05JAN2017	M.S	X.X

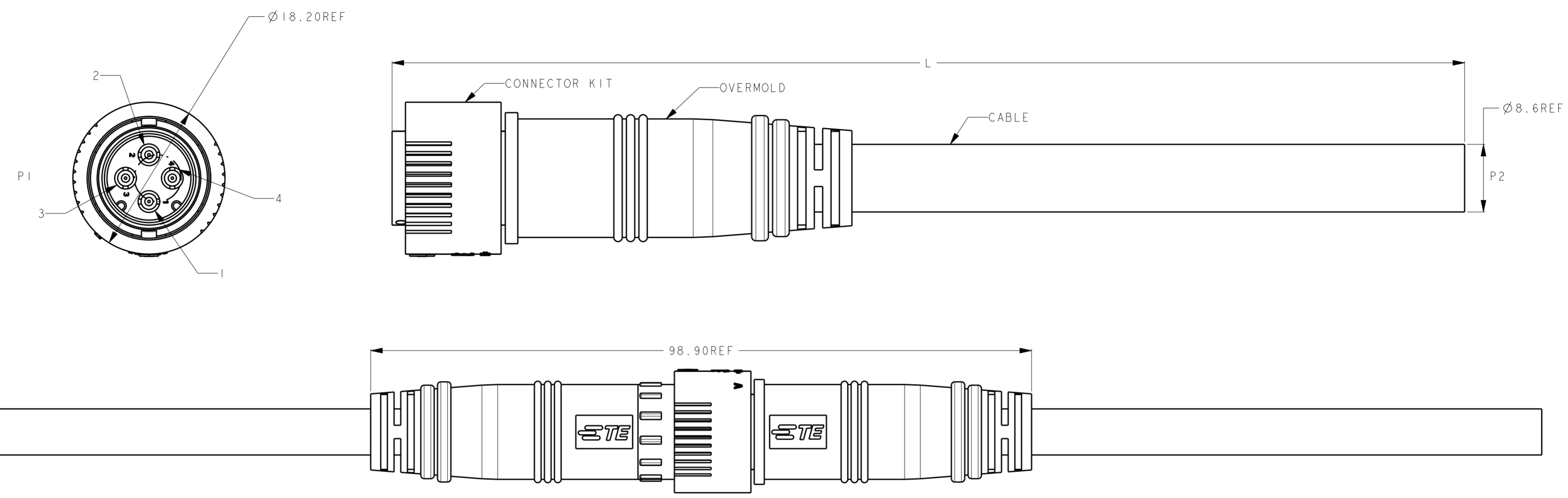

MATES WITH 2834005 SERIES

WIRING DIAGRAM		
P1	WIRE COLOR	P2
PI-1	RED	-
PI-2	WHITE	-
PI-3	BLACK	-
PI-4	BROWN	-

NOTES:
 1. MATE WITH 2834005 SERIES.
 2. RATINGS:
 VOLTAGE: 300V AC/DC
 CURRENT: 6A MAX.
 TEMPERATURE: 80°C

P/N	CABLE	DIM A	L (mm)
9-2834004-1	RUBBER (THERMOPLASTIC ELASTOMER TYPE)	Ø 8.5	150±5
9-2834004-2			250±10
9-2834004-3			500±15
9-2834004-4			1000±15

THIS DRAWING IS A CONTROLLED DOCUMENT.		DWN SHI MING 10SEP2014	TE Connectivity	
DIMENSIONS: mm		CHK SHI MING 10SEP2014		
TOLERANCES UNLESS OTHERWISE SPECIFIED:		APVD XU XIANG 10SEP2014	NAME 4P MALE CABLE ASSEMBLY	
0 PLC ±- 1 PLC ±1.0 2 PLC ±0.5 3 PLC ±- 4 PLC ±- ANGLES ±- FINISH ±-		PRODUCT SPEC 108-173041	SIZE A2	
MATERIAL		APPLICATION SPEC 114-173041	CAGE CODE -	DRAWING NO G-2834004
		WEIGHT -	RESTRICTED TO -	
		Customer Drawing		SCALE NTS
		SHEET 1 OF 2		REV BI

THIS DRAWING IS UNPUBLISHED. RELEASED FOR PUBLICATION 20
 © COPYRIGHT 20 BY - ALL RIGHTS RESERVED.

LOC		DIST		REVISIONS			
P	LTR	DESCRIPTION	DATE	DWN	APVD		
-	-	SEE SHEET 1	-	-	-		

1. PUT PIECES OF PARTS INTO THE PLASTIC BAG, AND SEALED WITH RUBBER BAND AS 1 BUNCH.

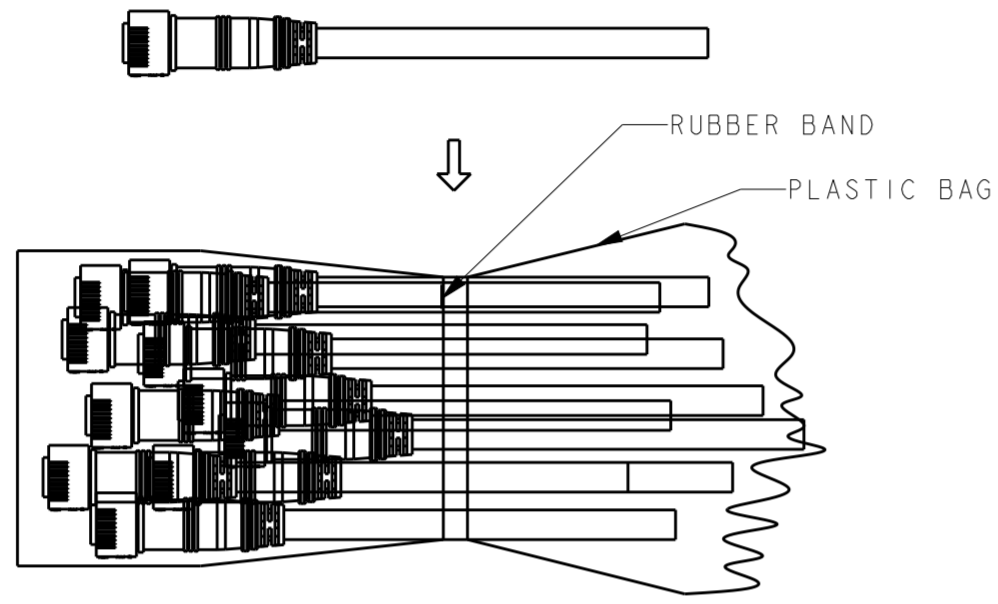

3. SEAL THE CARTON.

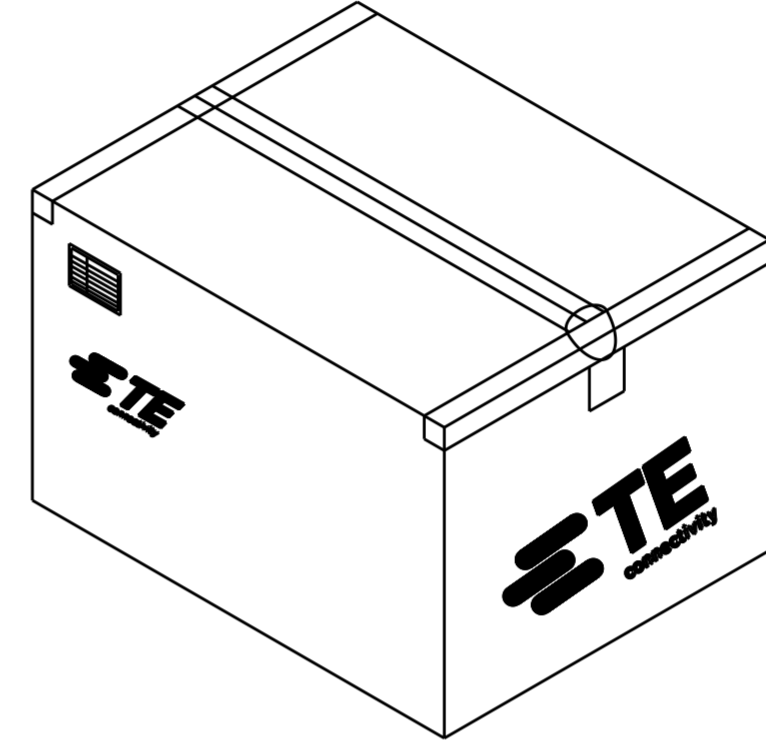

2. PUT BUNCHES OF PARTS INTO CARTON.

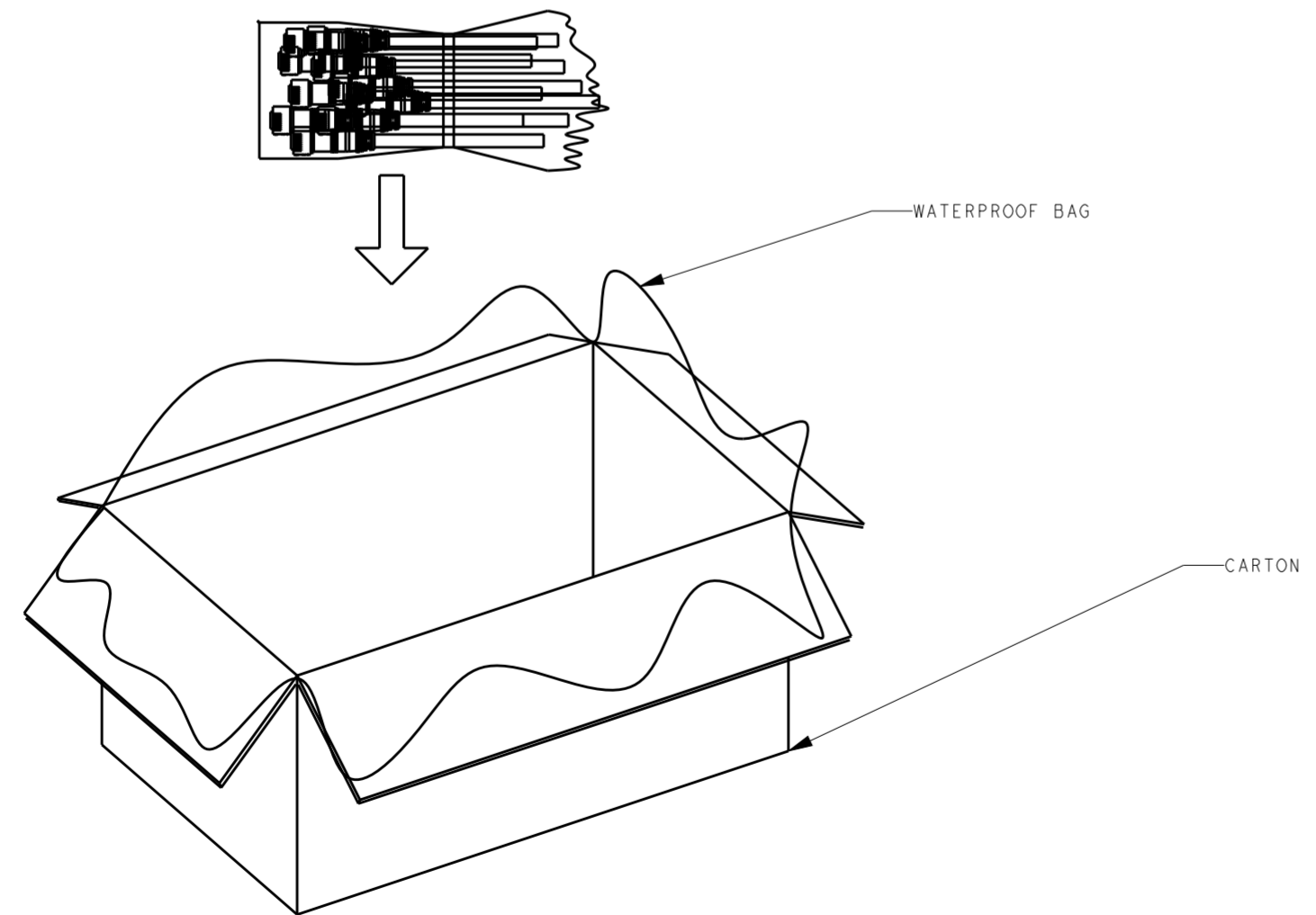

4. PACKAGING QUANTITIES (REFER SHEET 1 FOR PN DEFINITION):

P/N	PARTS PER CARTON (PCS)
9-2834004-1	500
9-2834004-2	260
9-2834004-3	90
9-2834004-4	60

THIS DRAWING IS A CONTROLLED DOCUMENT.		DWN SHI MING 10SEP2014	STE TE Connectivity	
DIMENSIONS: mm		CHK SHI MING 10SEP2014		
TOLERANCES UNLESS OTHERWISE SPECIFIED:		APVD XU XIANG 10SEP2014	NAME 4P MALE CABLE ASSEMBLY	
0 PLC ±		PRODUCT SPEC 108-173041	SIZE A2	
1 PLC ±1.0		APPLICATION SPEC 114-173041	CAGE CODE -	DRAWING NO C-2834004
2 PLC ±0.5		WEIGHT -	RESTRICTED TO -	SCALE NTS
3 PLC ±		MATERIAL -	SHEET 2 OF 2	REV BI
4 PLC ±		Customer Drawing		
ANGLES ±				
FINISH ±				