

Single-phase DC Brushless Motor Driver IC

■ GENERAL DESCRIPTION

The NJU7347 is single-phase DC brushless motor driver IC. It features MOS-FET driver circuit for better output characteristics.

It features Lock Detect, Frequency Generator Output and Thermal Shutdown Circuit.

Maximum output current is 200mA(12V). Input offset voltage is $\pm 7\text{mV}$.

It is suitable for 12V high current small fan-motor applications.

■ PACKAGE OUTLINE

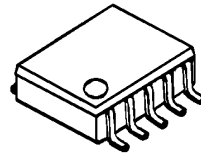

NJU7347R

■ FEATURES

- Operating Voltage 3.5 to 14V
- Frequency Generator Output
- Thermal Shutdown Circuit
- Lock Detect / Auto Release Circuit
- FG Output
- Low Operating Current
- Low Saturation Output Voltage
- $V_{\text{sat}} = \pm 0.3\text{V}$ @ $I_{\text{o}} = \pm 200\text{mA}$
- CMOS Technology
- Package Outline VSP10

■ BLOCK DIAGRAM

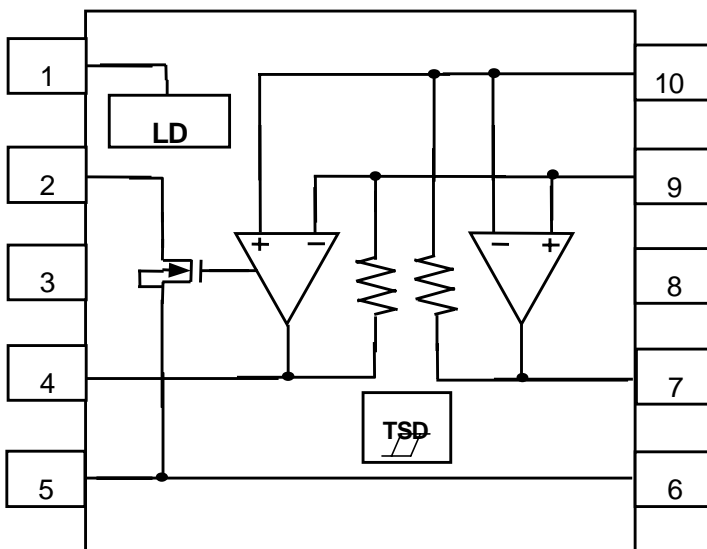

■ PIN FUNCTION

- 1: Ct
- 2: FG
- 3: V_{SS}
- 4: OUT B
- 5: V_{DD}
- 6: V_{DD}
- 7: OUT A
- 8: V_{SS}
- 9: IN-
- 10: IN+

(Note)

All V_{DD} and V_{SS} pins should be connected the power supply and the ground respectively. Otherwise, the electrical characteristic may not satisfy specifications

NJU7347

■ ABSOLUTE MAXIMUM RATINGS

(Ta=25°C)

PARAMETER	RATINGS	SYMBOL (unit)	NOTE
Supply Voltage	15.0	V _{DD} (V)	
Input Voltage	-0.3 ~ V _{DD} +0.3	V _{ID} (V)	
Output Current (Continuance)	200	I _O (mA)	
Output Current (Peak)	600	I _{OPEAK} (mA)	
Operating Temperature Range	-40 ~ +85	T _{opr} (°C)	
Storage Temperature Range	-50 ~ +150	T _{stg} (°C)	
Power Dissipation	400	P _D (mW)	Device itself

■ RECOMMENDED OPERATING CONDITIONS

(V_{DD} =12V, Ta=25°C)

PARAMETER	SYMBOL	CONDITION	MIN.	TYP.	MAX.	UNIT
Supply Voltage	V _{DD}	-	3.5	-	14.0	V
Output Current	I _O	-	-	-	200	mA

■ ELECTRICAL CHARACTERISTICS

PARAMETER	SYMBOL	CONDITION	MIN.	TYP.	MAX.	UNIT
General						
Operating Current	I_{DD}	-	-	3.0	5.0	mA
Thermal Shutdown Temperature	T_{TSD}	-	-	180	-	$^{\circ}C$
Thermal Shutdown Hysteresis	T_{HYS}	-	-	50	-	$^{\circ}C$
Hall Amplifier						
Input Offset Voltage	V_{IO}	-	-18	-	18	mV
Feedback Resistance	R_F	-	-	37.5	-	$k\Omega$
Input Common Mode Voltage Range	V_{ICM}	-	0.2~10.5	-	-	V
Output						
Maximum Output Voltage Range	V_{OH}	$I_o=+200mA$	11.55	11.70	-	V
	V_{OL}	$I_o=-200mA$	-	0.30	0.45	
Output Resistance	R_{ONH}	$I_o=+200mA$	-	1.5	-	Ω
	R_{ONL}	$I_o=-200mA$	-	1.5	-	
FG L Output Voltage	V_{FG}	$I_{FG}=5mA$	-	-	0.6	V
FG H Leak Current	$I_{FG-LEAK}$	$V_{FG}=12V$	-	-	1.0	μA
Lock Detect Circuit*						
Lock Protect Operation Voltage	V_{LOP}	-	4.0	-	-	V
Lock Detect Charge Current	I_{CHG}	-	-	3.2	-	μA
Lock Detect Discharge Current	I_{DCHG}	-	-	0.32	-	μA
Charge / Discharge Ratio	I_{CHG} / I_{DCHG}	-	-	10	-	
Clamp Voltage	V_{CL}	-	-	2.3	-	V
Detect Voltage	V_{ID}	-	-	0.6	-	V

NJU7347

■ TRUTH TABLE

Input			Output		
IN+	IN-	Ct	OUTA	OUTB	FG
H	L	L	H	L	H
L	H	L	L	H	L
H	L	H	H	Z	L
L	H	H	Z	H	L

■ POWER DISSIPATION

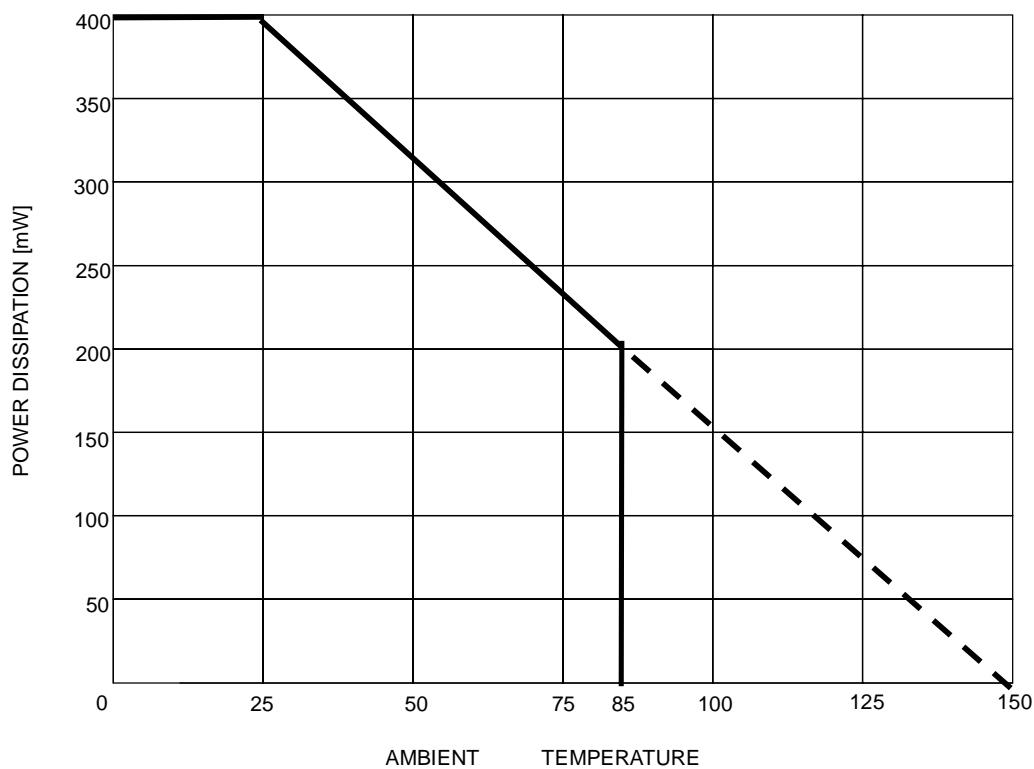

TYPICAL CHARACTERISTICS

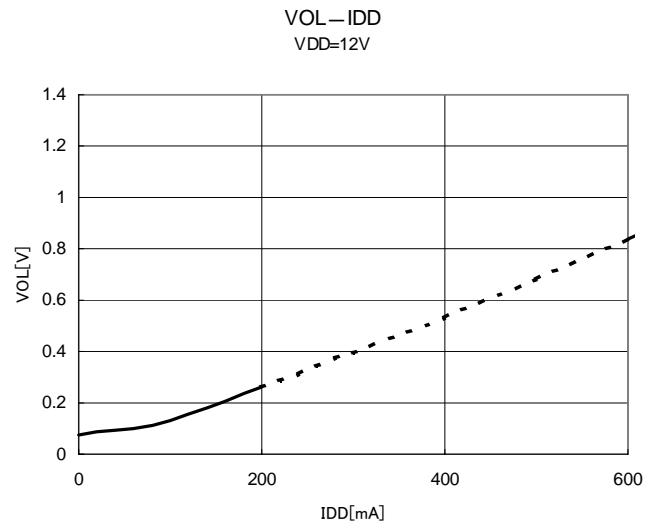
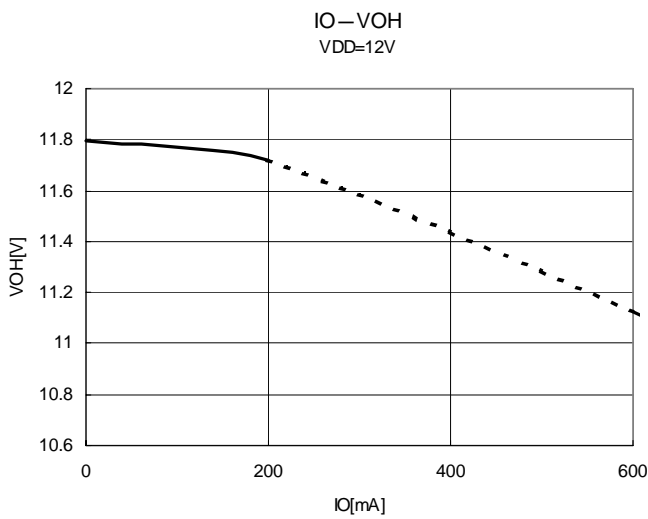
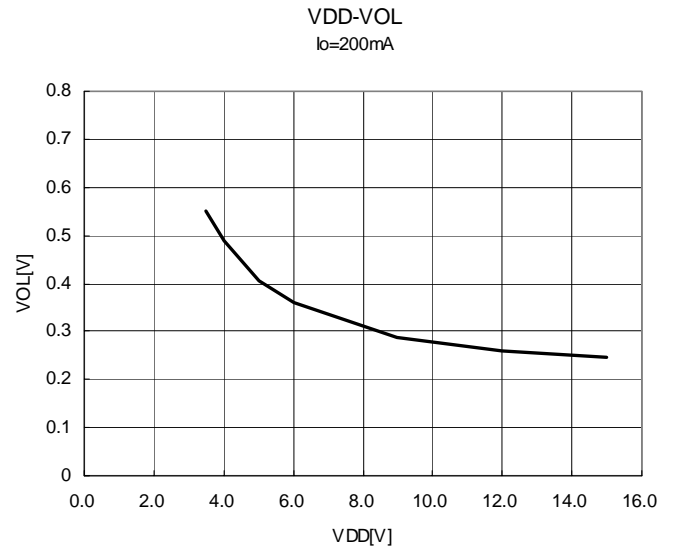
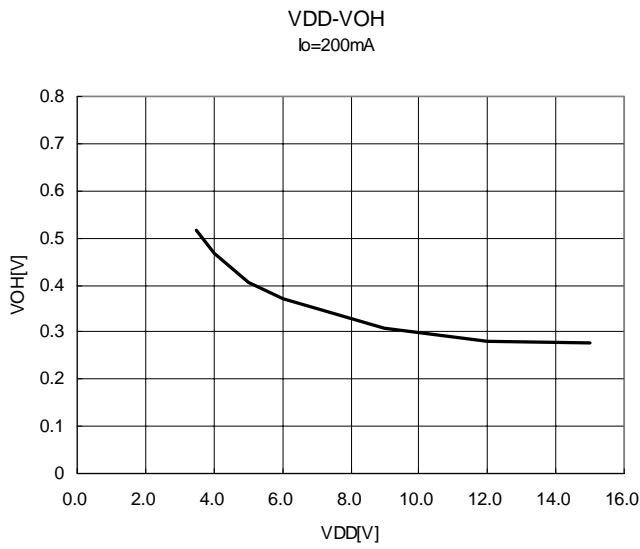
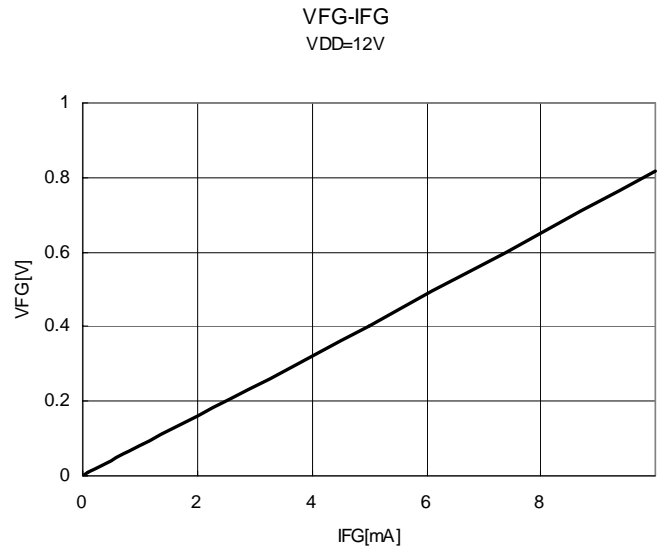
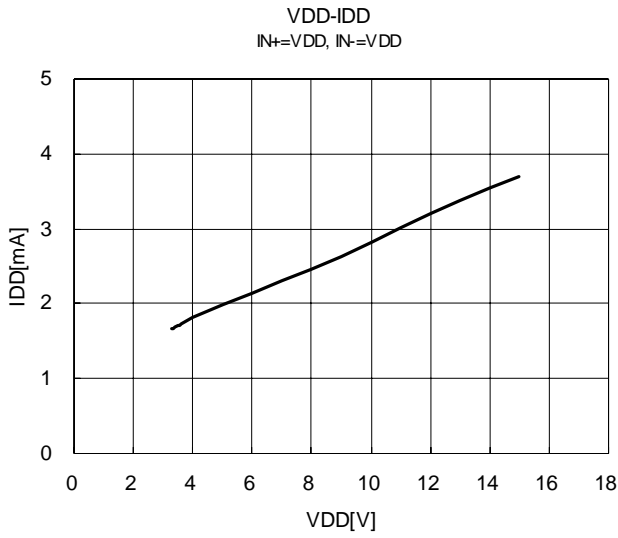

NJU7347

APPLICATION NOTE

The NJU7347 is a single-phase DC brushless motor driver IC in small VSP10 package. With minimal external components, It can drive up to 200mA of motor current for small fan application.

[Application Circuit Example]

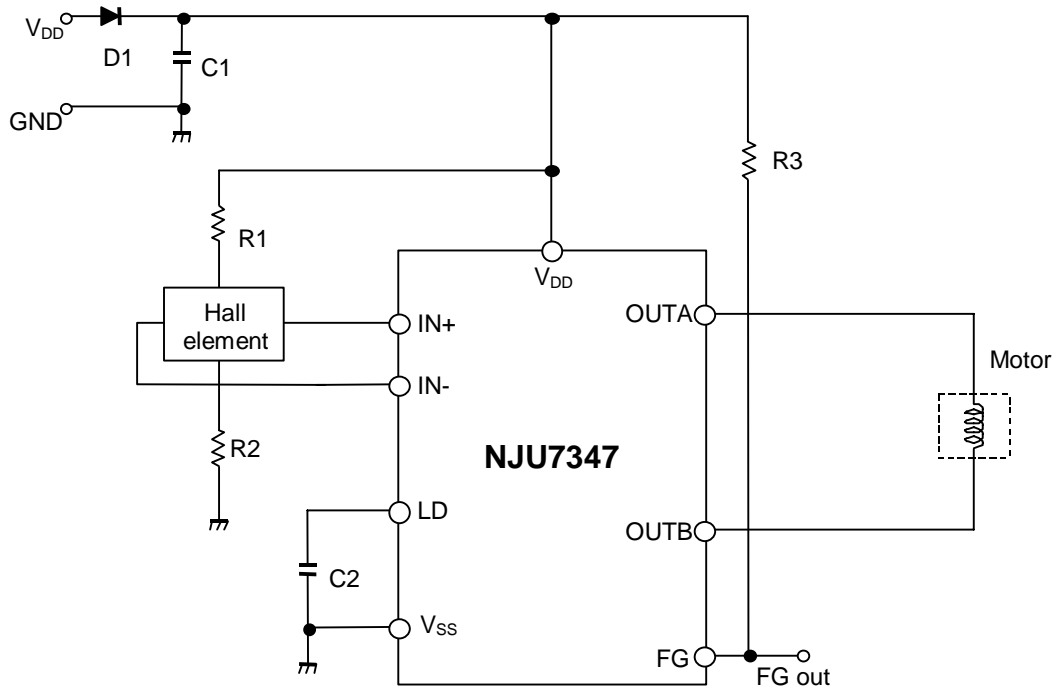

[Design Notes]

Above application example is designed for 12V operation with motor current of 200mA. It uses the following components:

Hall elements: HW101A (AKE)

1. Selection of **C1** and **D1**:

C1 is used for a noise reduction purpose. A typical value is 0.1uF.

Optimize the value in actual operating conditions if necessary. D1 is a diode for protection against reverse voltage supply. Silicon rectifier diode (WO3C, 10D1 and equivalent) is appropriate.

2. Lock Protection Function (Design of **C2** value):

Lock Protection Function, consists of Motor Lock Detection and Auto Resume Function, is a safety feature to protect a motor and a driver circuit from fatal destruction in case of motor halt.

Motor Lock Detection detects motor halt due to irregular load conditions and then cuts motor driving current for safety operation. A value of C2 determines Lock detection time (T_{on}) and Auto Resume Time (T_{off}).

Lock detection time (T_{on}) is given by:

$$T_{ON} = C2 \frac{V_{CL} - V_{ID}}{I_{CHG}} [\text{sec}]$$

Where C2 is 0.47uF:

$$T_{ON} = 0.47 \times 10^{-6} \times \frac{2.3 - 0.6}{3.2 \times 10^{-6}} = 0.25 [\text{sec}]$$

Auto Resume Time (Toff) is given by:

$$T_{OFF} = C2 \frac{V_{CL} - V_{ID}}{I_{DCHG}} [\text{sec}]$$

Where C2 is 0.47uF:

$$T_{OFF} = 0.47 \times 10^{-6} \times \frac{2.6 - 0.6}{0.32 \times 10^{-6}} = 2.5 [\text{sec}]$$

In actual application, Lock detection time (Ton) is affected by the mechanical time constant of a motor. Therefore, constant start up must be confirmed in actual evaluation taking operating variations (i.e. Temperature, Voltage change and so on) in consideration.

A typical value of C2 is either 0.47uF or 1uF depending on a motor.

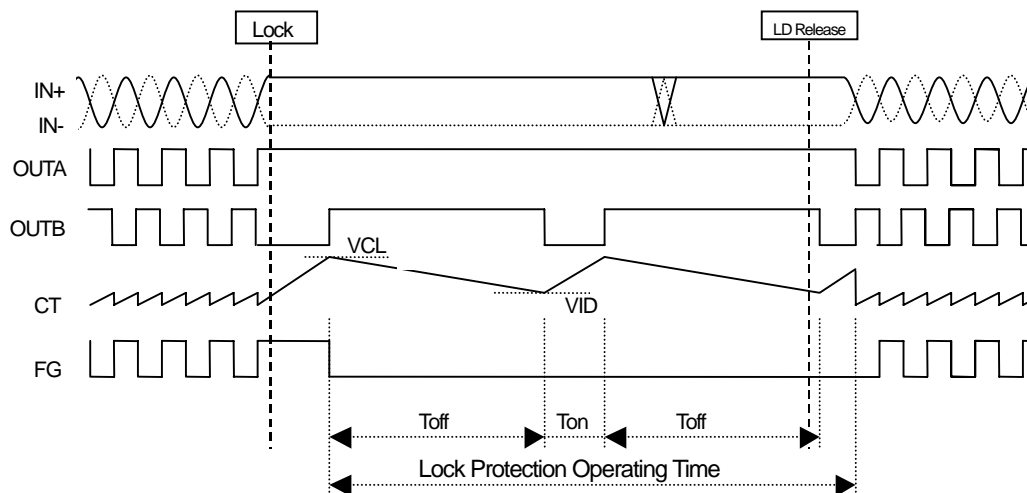

3. Design of hall element bias resistance (R1 and R2)

Hall amplifier is a differential amplifier.

The common-mode input voltage is between 0.2V and V_{DD}-4V and the input signal must be within the range. Non-excitation hall bias voltage is to be set at a half of V_{DD} for effective use of common-mode input voltage range. Therefore the same value of hall bias resistors is selected for R1 and R2.

Given that the bias current is set to be 5mA by HW101A datasheet, R1 and R2 can be determined as follows:

$$R1 + R2 + R_{in} = \frac{V_{DD}}{I_{hbias}} = \frac{12}{5 \times 10^{-3}} = 2.4k\Omega$$

$$R1 = R2 = 1k\Omega$$

NJU7347

The output voltage of hall elements is influenced by the bias current and magnetic flux density of hall elements.

The optimum input voltage of NJU7347 is 100mVp-p and higher. With such input voltage, the highest efficiency can be obtained.

4. Design of FG output resistance (R3)

FG Out(FG:Pin2) is an open drain output and R3 is a pull up resistor. A typical value of R3 is 10kΩ. The timing chart of FG Out is as follows.

Note that the pull up resistor shall be connected to below supply voltage.

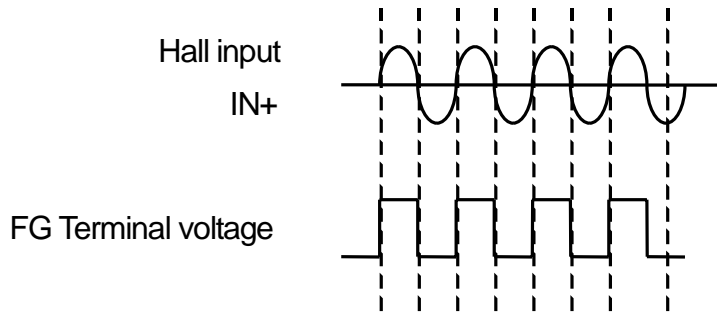

The specifications on this data book are only given for information, without any guarantee as regards either mistakes or omissions. The application circuit in this data book are described only to show representative usages of the product and not intended for the guarantee or permission of any right including the industrial rights.

book are described only to show representative usages of the product and not intended for the guarantee or permission of any right including the industrial rights.

Mouser Electronics

Authorized Distributor

Click to View Pricing, Inventory, Delivery & Lifecycle Information:

[NJR:](#)

[NJU7347R-TE1](#)