

EFM[®]32

... the world's most energy friendly microcontrollers

EFM32G Reference Manual

Gecko Series

- 32-bit ARM Cortex-M3 processor running at up to 32 MHz
- Up to 128 KB Flash and 16 KB RAM memory
- Energy efficient and autonomous peripherals
- Ultra low power Energy Modes with Sub μ operation
- Fast wake-up time of only 2 μ s

The EFM32G microcontroller series revolutionizes the 8- to 32-bit market with a combination of unmatched performance and ultra low power consumption in both active- and sleep modes. EFM32G devices consume as little as 180 μ A/MHz in run mode, and as little as 900 nA with a Real Time Counter running, Brown-out and full RAM and register retention.

EFM32G's low energy consumption outperforms any other available 8-, 16-, and 32-bit solution. The EFM32G includes autonomous and energy efficient peripherals, high overall chip- and analog integration, and the performance of the industry standard 32-bit ARM Cortex-M3 processor.

1 Energy Friendly Microcontrollers

1.1 Typical Applications

The EFM32G Gecko is the ideal choice for demanding 8-, 16-, and 32-bit energy sensitive applications. The devices are developed to minimise the product of power and time over all phases of MCU operation. This unique combination of ultra low energy consumption and the performance of the 32-bit ARM Cortex-M3 processor helps designers get more out of the available energy source in a variety of applications.

Ultra low energy EFM32G microcontrollers are perfect for:

- Gas metering
- Energy metering
- Water metering
- Smart metering
- Alarm and security systems
- Health and fitness applications
- Industrial and home automation

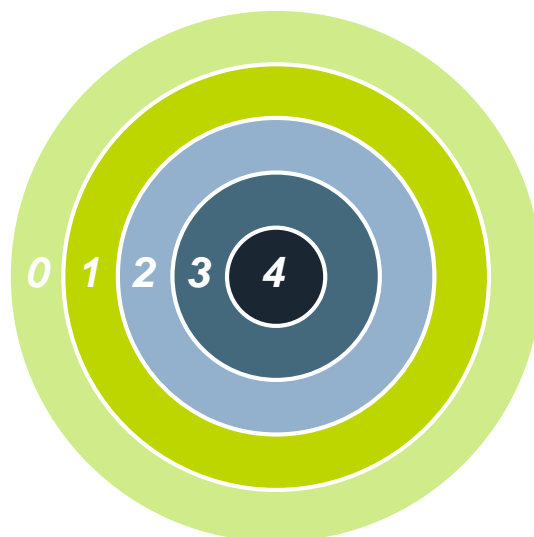

1.2 EFM32G Development

Because EFM32G microcontrollers include the ARM Cortex-M3 CPU, embedded designers benefit from a large existing ecosystem of industry standard development. The development suite spans the whole design process and includes powerful debug tools and some of the world's top brand compilers. Libraries with documentation and user examples shorten time from idea to market release.

The range of EFM32G devices ensures easy migration and feature upgrade possibilities.

2 About This Document

This document contains reference material for the EFM32G series of microcontrollers. All modules and peripherals in the EFM32G series devices are described in general terms. Not all modules are present in all devices and the feature set for each device might vary. Such differences, including pinout, are covered in the device-specific datasheets.

2.1 Conventions

Register Names

Register names are given with a module name prefix followed by the short register name:

TIMERn_CTRL - Control Register

The "n" denotes the module number for modules which can exist in more than one instance.

Some registers are grouped which leads to a group name following the module prefix:

GPIO_Px_DOUT - Port Data Out Register

The "x" denotes the port instance (A,B,...)

Bit Fields

Registers contain one or more bit fields which can be 1 to 32 bits wide. Bit fields wider than 1 bit are given with start and stop bit (x:y).

Address

The address for each register can be found by adding the modules base address (found in Memory Map), with the offset address for the register (found in module Register Map).

Access Type

The register access types used in the register descriptions are explained in Table 2.1 (p. 3) .

Table 2.1. Register Access Types

Access Type	Description
R	Read only. Writes are ignored
RW	Readable and writable
RW1	Readable and writable. Only writes to 1 have effect
W1	Read value undefined. Only writes to 1 have effect
W	Write only. Read value undefined.
RWH	Readable, writable and updated by hardware

Number format

0x prefix is used for hexadecimal numbers

0b prefix is used for binary numbers

Numbers without prefix are in decimal representation.

Reserved

Registers and bit fields marked with *reserved* are reserved for future use. These should be written to 0 unless otherwise stated in the Register Description. Reserved bits might be read as 1 in future devices.

Reset Value

The reset value denotes the value after reset.

Registers denoted with X have unknown value out of reset and need to be initialized before use. Note that read-modify-write operations on these registers before they are initialized results in undefined register values.

Pin Connections

Pin connections are given with a module prefix followed by a short pin name:

USn_TX (USART n TX pin)

The location for the pin names given in the module documentation can be found in the device-specific datasheet.

2.2 Related Documentation

Further documentation on the EFM32G family and the ARM Cortex-M3 can be found at the Energy Micro and ARM web pages:

www.energymicro.com

www.arm.com

3 System Overview

3.1 Introduction

The EFM32 MCUs are the world's most energy friendly microcontrollers. With a unique combination of the powerful 32-bit ARM Cortex-M3, innovative low energy techniques, short wake-up time from energy saving modes, and a wide selection of peripherals, the EFM32G microcontroller is well suited for any battery operated application as well as other systems requiring high performance and low-energy consumption, see Figure 3.1 (p. 7) .

3.2 Features

- **ARM Cortex-M3 CPU platform**
 - High Performance 32-bit processor @ up to 32 MHz
 - Memory Protection Unit
 - Wake-up Interrupt Controller
- **Flexible Energy Management System**
 - 20 nA @ 3 V Shutoff Mode
 - 0.6 μ A @ 3 V Stop Mode, including Power-on Reset, Brown-out Detector, RAM and CPU retention
 - 0.9 μ A @ 3 V Deep Sleep Mode, including Real Time Clock with 32.768 kHz oscillator, Power-on Reset, Brown-out Detector, RAM and CPU retention
 - 45 μ A/MHz @ 3 V Sleep Mode
 - 180 μ A/MHz @ 3 V Run Mode, with code executed from flash
- **128/64/32/16 KB Flash**
- **16/8 KB RAM**
- **Up to 90 General Purpose I/O pins**
 - Configurable Push-pull, Open-drain, pull-up/down, input filter, drive strength
 - Configurable peripheral I/O locations
 - 16 asynchronous external interrupts
- **8 Channel DMA Controller**
 - Alternate/primary descriptors with scatter-gather/ping-pong operation
- **8 Channel Peripheral Reflex System for autonomous inter-peripheral signaling**
- **External Bus Interface for up to 64 MB of external memory mapped space**
- **Integrated LCD Controller for up to 4x40 segments**
 - Voltage boost, adjustable contrast adjustment and autonomous animation feature
- **Hardware AES with 128/256-bit keys in 54/75 cycles**
- **Communication interfaces**
 - 3x Universal Synchronous/Asynchronous Receiver/Transmitter
 - UART/SPI/SmartCard (ISO 7816)/IrDA
 - Triple buffered full/half-duplex operation
 - 4-16 data bits
 - Universal Asynchronous Receiver/Transmitter
 - Triple buffered full/half-duplex operation
 - 8-9 data bits
 - 2x Low Energy UART
 - Autonomous operation with DMA in Deep Sleep Mode
 - I²C Interface with SMBus support
 - Address recognition in Stop Mode
- **Timers/Counters**
 - 3x 16-bit Timer/Counter
 - 3 Compare/Capture/PWM channels

- Dead-Time Insertion on TIMER0
- 16-bit Low Energy Timer
- 24-bit Real-Time Counter
- 3x 8-bit Pulse Counter
 - Asynchronous pulse counting/quadrature decoding
- Watchdog Timer with dedicated RC oscillator @ 50 nA
- **Ultra low power precision analog peripherals**
 - 12-bit 1 Msamples/s Analog to Digital Converter
 - 8 input channels and on-chip temperature sensor
 - Single ended or differential operation
 - Conversion tailgating for predictable latency
 - 12-bit 500 ksamples/s Digital to Analog Converter
 - 2 single ended channels/1 differential channel
 - 2x Analog Comparator
 - Programmable speed/current
 - Capacitive sensing with up to 8 inputs
 - Supply Voltage Comparator
- **Ultra efficient Power-on Reset and Brown-Out Detector**
- **2-pin Serial Wire Debug interface**
 - 1-pin Serial Wire Viewer
- **Temperature range -40 - 85°C**
- **Single power supply 1.8 - 3.8 V**
- **Packages**
 - QFN32
 - QFN64
 - LQFP100
 - BGA112

3.3 Block Diagram

A block diagram of EFM32G is shown in Figure 3.1 (p. 7). The color indicates peripheral availability in energy modes as described in Section 3.4 (p. 7) .

Figure 3.1. Diagram of EFM32G

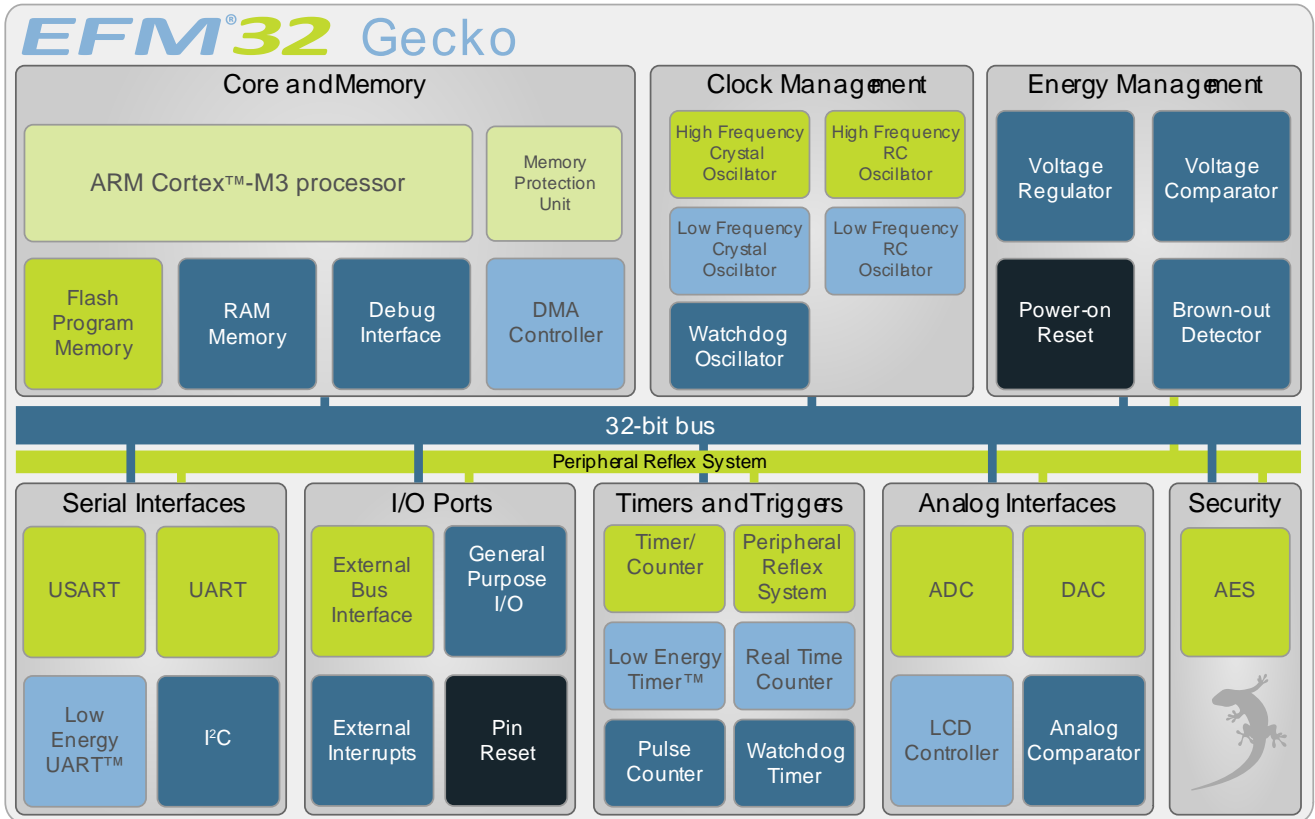

Note

In the block diagram, color indicates availability in different energy modes.

Figure 3.2. Energy Mode indicator

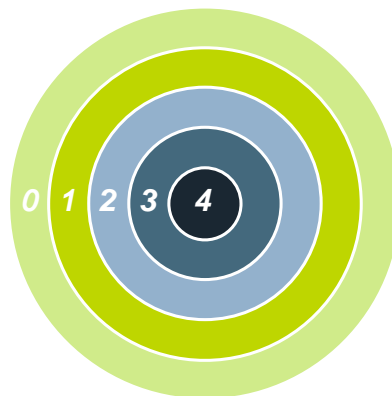

Note

In the energy mode indicator, the number n indicates Energy Mode n.

3.4 Energy Modes

There are five different Energy Modes (EM0-EM4) in the EFM32G, see Table 3.1 (p. 8). The EFM32G is designed to achieve a high degree of autonomous operation in low energy modes. The intelligent combination of peripherals, RAM with data retention, DMA, low-power oscillators and short wake-up times, makes it attractive to remain in low energy modes for long periods and thus saving energy consumption.

Tip

Throughout this document, the first figure in every module description contains an Energy Mode Indicator that shows in which energy mode(s) the module can operate (see Table 3.1 (p. 8)).

Table 3.1. Energy Mode Description

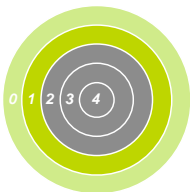
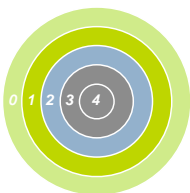
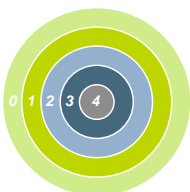
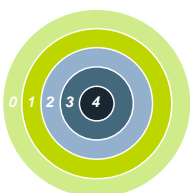
Energy Mode	Name	Description
	EM0 – Energy Mode 0 (Run mode)	In EM0, the CPU is running and consuming as little as 180 μA/MHz, when running code from flash. All peripherals can also be activated.
	EM1 – Energy Mode 1 (Sleep Mode)	In EM1, the CPU is sleeping and the power consumption is only 45 μA/MHz . The peripherals including, DMA, PRS and memory system is still available.
	EM2 – Energy Mode 2 (Deep Sleep Mode)	In EM2 the high frequency oscillator is turned off, but with the 32.768 kHz oscillator running, selected low energy peripherals (LCD, RTC, LETIMER, PCNT, WDOG, LEUART, I ² C, ACMP) are still available, giving a high degree of autonomous operation with a current consumption as low as 0.9 μA with RTC enabled. Power-on Reset, Brown-out Detection and full RAM and CPU retention is also included.
	EM3 - Energy Mode 3 (Stop Mode)	In EM3 the low-frequency oscillator is disabled, but there is still full CPU and RAM retention, as well as Power-on Reset, Pin reset and Brown-out Detector, with a consumption of only 0.6 μA. The low-power ACMP, asynchronous external interrupt, PCNT, and I ² C can wake-up the device. Even in this mode, the wake-up time is in the range of a few microseconds.
	EM4 – Energy Mode 4 (Shutoff Mode)	In EM4, the current is down to 20 nA and all chip functionality is turned off except the pin reset and the power on reset. All pins are put into their reset state.

3.5 Product Overview

Table 3.2 (p. 9) shows a device overview of the EFM32G Microcontroller Series, including peripheral functionality. For more information, the reader is referred to the device specific datasheets.

Table 3.2. EFM32G Microcontroller Series

EFM32G Part #	Flash	RAM	GPIO(pins)	LCD	USART+UART	LEUART	I ² C	Timer(PWM)	LETIMER	RTC	PCNT	Watchdog	ADC(pins)	DAC(pins)	ACMP(pins)	AES	EBI	Package
200F16	16	8	24	-	2	1	1	2 (6)	1	1	1	1	1 (4)	1 (1)	2 (5)	-	-	QFN32
200F32	32	8	24	-	2	1	1	2 (6)	1	1	1	1	1 (4)	1 (1)	2 (5)	-	-	QFN32
200F64	64	16	24	-	2	1	1	2 (6)	1	1	1	1	1 (4)	1 (1)	2 (5)	-	-	QFN32
210F128	128	16	24	-	2	1	1	2 (6)	1	1	1	1	1 (4)	1 (1)	2 (5)	Y	-	QFN32
230F32	32	8	56	-	3	2	1	3 (9)	1	1	3	1	1 (8)	2 (2)	2 (16)	Y	-	QFN64
230F64	64	16	56	-	3	2	1	3 (9)	1	1	3	1	1 (8)	2 (2)	2 (16)	Y	-	QFN64
230F128	128	16	56	-	3	2	1	3 (9)	1	1	3	1	1 (8)	2 (2)	2 (16)	Y	-	QFN64
280F32	32	8	85	-	3+1	2	1	3 (9)	1	1	3	1	1 (8)	2 (2)	2 (16)	Y	Y	LQFP100
280F64	64	16	85	-	3+1	2	1	3 (9)	1	1	3	1	1 (8)	2 (2)	2 (16)	Y	Y	LQFP100
280F128	128	16	85	-	3+1	2	1	3 (9)	1	1	3	1	1 (8)	2 (2)	2 (16)	Y	Y	LQFP100
290F32	32	8	90	-	3+1	2	1	3 (9)	1	1	3	1	1 (8)	2 (2)	2 (16)	Y	Y	BGA112
290F64	64	16	90	-	3+1	2	1	3 (9)	1	1	3	1	1 (8)	2 (2)	2 (16)	Y	Y	BGA112
290F128	128	16	90	-	3+1	2	1	3 (9)	1	1	3	1	1 (8)	2 (2)	2 (16)	Y	Y	BGA112
840F32	32	8	56	4x24	3	2	1	3 (9)	1	1	3	1	1 (8)	2 (2)	2 (8)	Y	-	QFN64
840F64	64	16	56	4x24	3	2	1	3 (9)	1	1	3	1	1 (8)	2 (2)	2 (8)	Y	-	QFN64
840F128	128	16	56	4x24	3	2	1	3 (9)	1	1	3	1	1 (8)	2 (2)	2 (8)	Y	-	QFN64
880F32	32	8	85	4x40	3+1	2	1	3 (9)	1	1	3	1	1 (8)	2 (2)	2 (16)	Y	Y ¹	LQFP100
880F64	64	16	85	4x40	3+1	2	1	3 (9)	1	1	3	1	1 (8)	2 (2)	2 (16)	Y	Y ¹	LQFP100
880F128	128	16	85	4x40	3+1	2	1	3 (9)	1	1	3	1	1 (8)	2 (2)	2 (16)	Y	Y ¹	LQFP100
890F32	32	8	90	4x40	3+1	2	1	3 (9)	1	1	3	1	1 (8)	2 (2)	2 (16)	Y	Y ¹	BGA112
890F64	64	16	90	4x40	3+1	2	1	3 (9)	1	1	3	1	1 (8)	2 (2)	2 (16)	Y	Y ¹	BGA112
890F128	128	16	90	4x40	3+1	2	1	3 (9)	1	1	3	1	1 (8)	2 (2)	2 (16)	Y	Y ¹	BGA112

¹EBI and LCD overlaps in the part. Only a reduced pin count LCD driver can be used simultaneously with the EBI.

4 System Processor

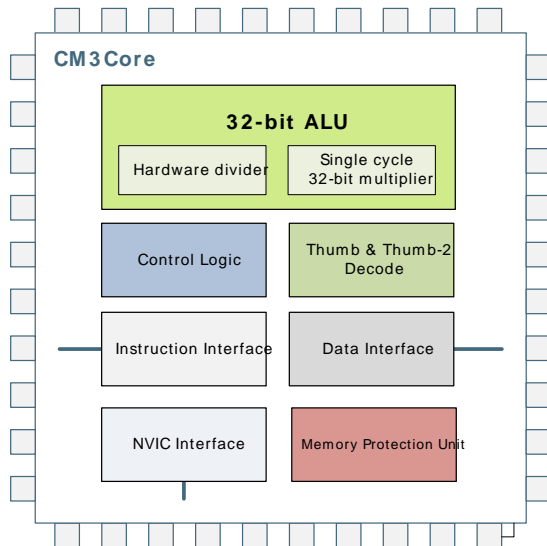
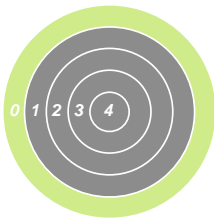

Quick Facts

What?

The industry leading Cortex-M3 processor from ARM is the CPU in the EFM32G microcontrollers.

Why?

The ARM Cortex-M3 is designed for exceptional short response time, high code density, and high 32-bit throughput while maintaining a strict cost and power consumption budget.

How?

Combined with the ultra low energy peripherals available in EFM32G devices, the Cortex-M3 processor's Harvard architecture and 3 stage pipeline, single cycle instructions and Thumb-2 instruction set support, and fast interrupt handling makes it perfect for 8- to 32-bit applications.

4.1 Introduction

The ARM Cortex-M3 32-bit RISC processor provides outstanding computational performance and exceptional system response to interrupts while meeting low cost requirements and low power consumption.

The ARM Cortex-M3 implemented is revision r2p0.

4.2 Features

- Harvard architecture
 - Separate data and program memory buses (No memory bottleneck as in a single bus system)
- 3-stage pipeline
- Thumb-2 instruction set
 - Enhanced levels of performance, energy efficiency, and code density
- Single cycle multiply and hardware divide instructions
 - 32-bit multiplication in a single cycle
 - Signed and unsigned divide operations between 2 and 12 cycles
- Atomic bit manipulation with bit banding
 - Direct access to single bits of data
 - Two 1MB bit banding regions for memory and peripherals mapping to 32MB alias regions
 - Atomic operation, cannot be interrupted by other bus activities
- 1.25 DMIPS/MHz
- Memory Protection Unit
 - Up to 8 protected memory regions
- 24 bits System Tick Timer for Real Time OS
- Excellent 32-bit migration choice for 8/16 bit architecture based designs

- Simplified stack-based programmer's model is compatible with traditional ARM architecture and retains the programming simplicity of legacy 8- and 16-bit architectures
- Unaligned data storage and access
 - Continuous storage of data requiring different byte lengths
 - Data access in a single core access cycle
- Integrated power modes
 - Sleep Now mode for immediate transfer to low power state
 - Sleep on Exit mode for entry into low power state after the servicing of an interrupt
 - Ability to extend power savings to other system components
- Optimized for low latency, nested interrupts

4.3 Functional Description

For a full functional description of the ARM Cortex-M3 (r2p0) implementation in the EFM32G family, the reader is referred to the *EFM32G Cortex-M3 Reference Manual*.

4.3.1 Interrupt Operation

Figure 4.1. Interrupt Operation

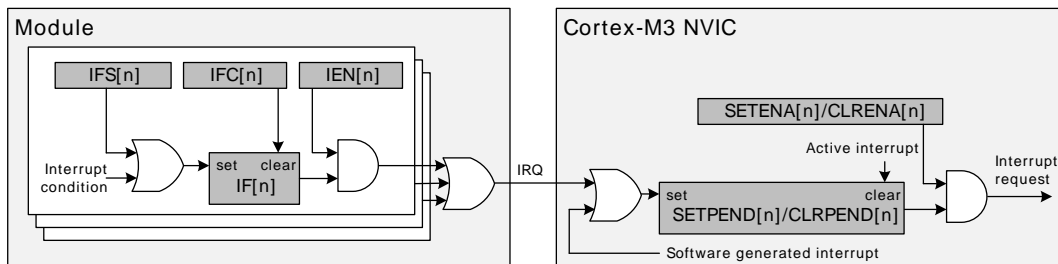

The EFM32G devices have up to 31 interrupt request lines (IRQ) which are connected to the Cortex-M3. Each of these lines (shown in Table 4.1 (p. 12)) is connected to one or more interrupt flags in one or more modules. The interrupt flags are set by hardware on an interrupt condition. It is also possible to set/clear the interrupt flags through the IFS/IFC registers. Each interrupt flag is then qualified with its own interrupt enable bit (IEN register), before being OR'ed with the other interrupt flags to generate the IRQ. A high IRQ line will set the corresponding pending bit (can also be set/cleared with the SETPEND/CLRPEND bits in ISPR0/ICPR0) in the Cortex-M3 NVIC. The pending bit is then qualified with a an enable bit (set/cleared with SETENA/CLRENA bits in ISER0/ICER0) before generating an interrupt request to the core. Figure 4.1 (p. 11) illustrates the interrupt system. For more information on how the interrupts are handled inside the Cortex-M3, the reader is referred to the *EFM32G Cortex-M3 Reference Manual*.

Table 4.1. Interrupt Request Lines (IRQ)

IRQ #	Source
0	DMA
1	GPIO_EVEN
2	TIMER0
3	USART0_RX
4	USART0_TX
5	ACMP0/ACMP1
6	ADC0
7	DAC0
8	I2C0
9	GPIO_ODD
10	TIMER1
11	TIMER2
12	USART1_RX
13	USART1_TX
14	USART2_RX
15	USART2_TX
16	UART0_RX
17	UART0_TX
18	LEUART0
19	LEUART1
20	LETIMER0
21	PCNT0
22	PCNT1
23	PCNT2
24	RTC
25	CMU
26	VCMP
27	LCD
28	MSC
29	AES

5 Memory and Bus System

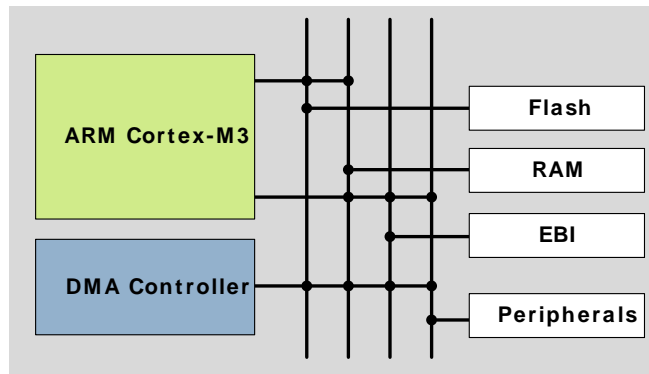
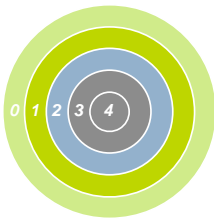

Quick Facts

What?

A low latency memory system including low energy Flash and RAM with data retention which makes the energy modes attractive.

Why?

RAM retention reduces the need for storing data in Flash and enables frequent use of the ultra low energy modes EM2 and EM3 with as little as 0.6 μA μA current consumption.

How?

Low energy and non-volatile Flash memory stores program and application data in all energy modes and can easily be reprogrammed in system. Low leakage RAM with data retention in EM0 to EM3 removes the data restore time penalty, and the DMA ensures fast autonomous transfers with predictable response time.

5.1 Introduction

The EFM32G contains an AMBA AHB Bus system to allow bus masters to access the memory mapped address space. A multilayer AHB bus matrix connects the 4 master bus interfaces to the AHB slaves (Figure 5.1 (p. 14)). The bus matrix allows several AHB slaves to be accessed simultaneously. An AMBA APB interface is used for the peripherals, which are accessed through an AHB-to-APB bridge connected to the AHB bus matrix. The 4 AHB bus masters are:

- **Cortex-M3 ICode:** Used for instruction fetches from Code memory (0x00000000 - 0x1FFFFFFF)
- **Cortex-M3 DCode:** Used for debug and data access to Code memory (0x00000000 - 0x1FFFFFFF)
- **Cortex-M3 System:** Used for instruction fetches, data and debug access to system space (0x20000000 - 0xDFFFFFFF, 0xE0100000 - 0xFFFFFFFF)
- **DMA:** Can access entire memory space (0x00000000 - 0xFFFFFFFF)

Figure 5.1. EFM32G Bus System

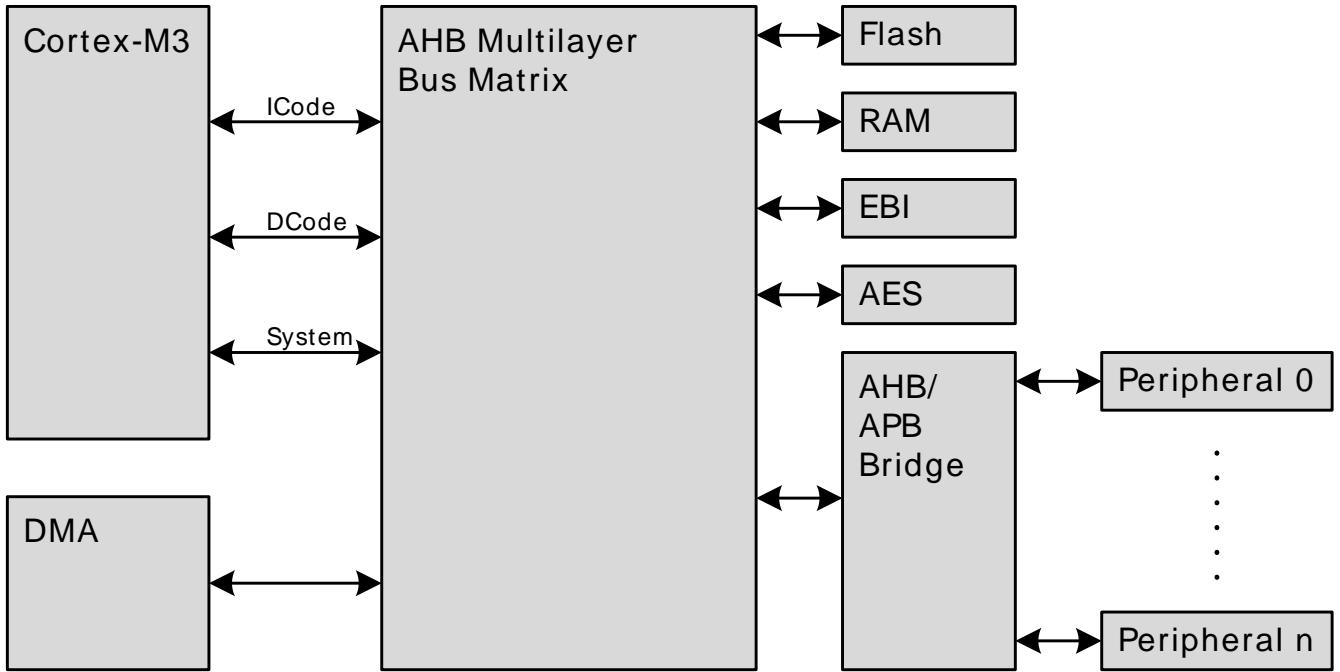

5.2 Functional Description

The memory segments are mapped together with the internal segments of the Cortex-M3 into the system memory map shown by Figure 5.2 (p. 14)

Figure 5.2. System Address Space

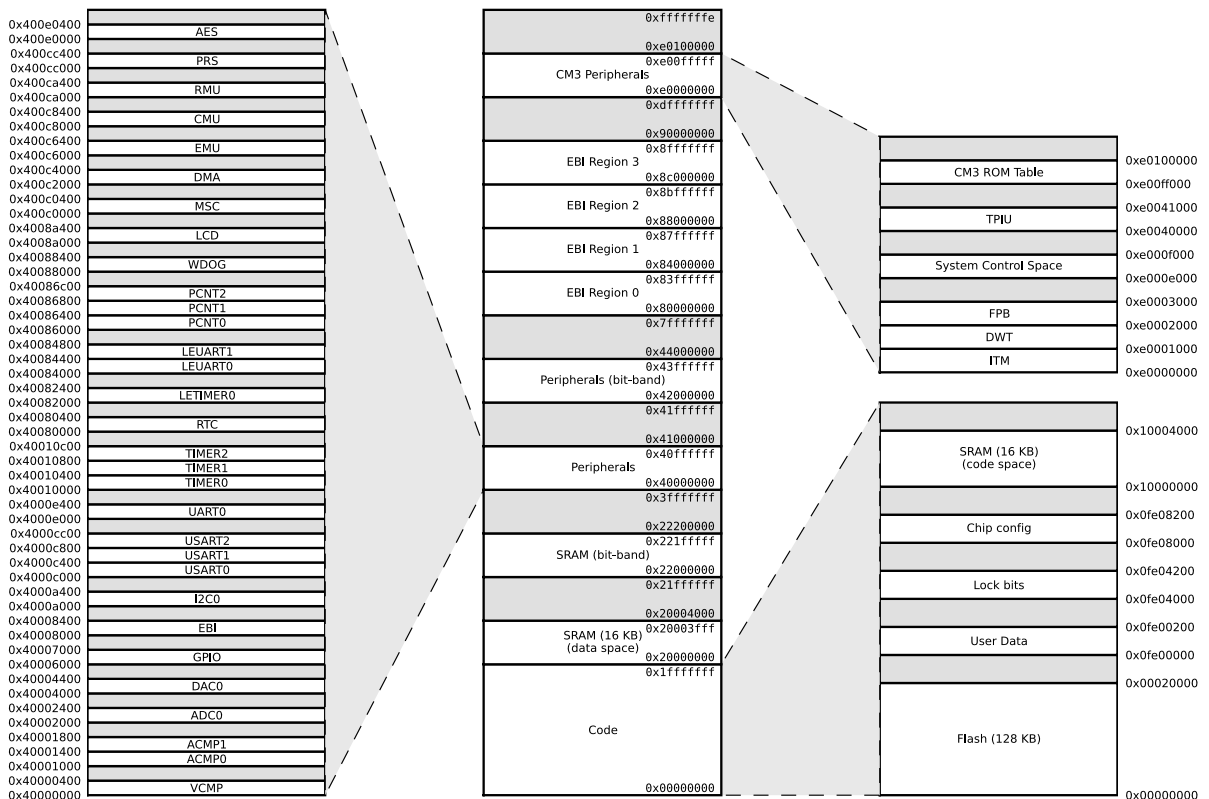

The embedded SRAM is located at address 0x20000000 in the memory map of the EFM32G. When running code located in SRAM starting at this address, the Cortex-M3 uses the System bus interface to fetch instructions. This results in reduced performance as the Cortex-M3 accesses stack, other data in SRAM and peripherals using the System bus interface. To be able to run code from SRAM efficiently, the SRAM is also mapped in the code space at address 0x10000000. When running code from this space, the Cortex-M3 fetches instructions through the I/D-Code bus interface, leaving the System bus interface for data access. The SRAM mapped into the code space can however only be accessed by the CPU, i.e. not the DMA.

5.2.1 Bit-banding

The SRAM bit-band alias and peripheral bit-band alias regions are located at 0x22000000 and 0x42000000 respectively. Read and write operations to these regions are converted into masked single-bit reads and atomic single-bit writes to the embedded SRAM and peripherals of the EFM32G.

Using a standard approach to modify a single register or SRAM bit in the aliased regions, would require software to read the value of the byte, half-word or word containing the bit, modify the bit, and then write the byte, half-word or word back to the register or SRAM address. Using bit-banding, this can be done in a single operation. As read-writeback, bit-masking and bit-shift operations are not necessary in software, code size is reduced and execution speed improved.

The bit-band regions allow each bit in the SRAM and Peripheral areas of the memory map to be addressed. To set or clear a bit in the embedded SRAM, write a 1 or a 0 to the following address:

Memory SRAM Area Set/Clear Bit

$$\text{bit_address} = 0x22000000 + (\text{address} - 0x20000000) \times 32 + \text{bit} \times 4 \quad (5.1)$$

where address is the address of the 32-bit word containing the bit to modify, and bit is the index of the bit in the 32-bit word.

To modify a bit in the Peripheral area, use the following address:

Memory Peripheral Area Bit Modification

$$\text{bit_address} = 0x42000000 + (\text{address} - 0x40000000) \times 32 + \text{bit} \times 4 \quad (5.2)$$

5.2.2 Peripherals

The peripherals are mapped into the peripheral memory segment, each with a fixed size address range according to Table 5.1 (p. 16) , Table 5.2 (p. 16) , and Table 5.3 (p. 17)

Table 5.1. Memory System Core Peripherals

Core peripherals	
Address range	Peripheral
0x400E0400 – 0x41FFFFFF	Reserved
0x400E0000 – 0x400E03FF	AES
0x400CC400 – 0x400FFFFFF	Reserved
0x400CC000 – 0x400CC3FF	PRS
0x400CA400 – 0x400CBFFF	Reserved
0x400CA000 – 0x400CA3FF	RMU
0x400C8400 – 0x400C9FFF	Reserved
0x400C8000 – 0x400C83FF	CMU
0x400C6400 – 0x400C7FFF	Reserved
0x400C6000 – 0x400C63FF	EMU
0x400C4000 – 0x400C5FFF	Reserved
0x400C2000 – 0x400C3FFF	DMA
0x400C0400 – 0x400C1FFF	Reserved
0x400C0000 – 0x400C03FF	MSC

Table 5.2. Memory System Low Energy Peripherals

Low energy peripherals	
Address range	Peripheral
0x4008A400 – 0x400BFFFF	Reserved
0x4008A000 – 0x4008A3FF	LCD
0x40088400 – 0x40089FFF	Reserved
0x40088000 – 0x400883FF	WDOG
0x40086C00 – 0x40087FFF	Reserved
0x40086800 – 0x40086BFF	PCNT2
0x40086400 – 0x400867FF	PCNT1
0x40086000 – 0x400863FF	PCNT0
0x40084800 – 0x40085FFF	Reserved
0x40084400 – 0x400847FF	LEUART1
0x40084000 – 0x400843FF	LEUART0
0x40082400 – 0x40083FFF	Reserved
0x40082000 – 0x400823FF	LETIMER0
0x40080400 – 0x40081FFF	Reserved
0x40080000 – 0x400803FF	RTC

Table 5.3. Memory System Peripherals

Peripherals	
Address range	Peripheral
0x40010C00 – 0x4007FFFF	Reserved
0x40010800 – 0x40010BFF	TIMER2
0x40010400 – 0x400107FF	TIMER1
0x40010000 – 0x400103FF	TIMER0
0x4000E400 – 0x4000FFFF	Reserved
0x4000E000 – 0x4000E3FF	UART0
0x4000CC00 – 0x4000DFFF	Reserved
0x4000C800 – 0x4000CBFF	USART2
0x4000C400 – 0x4000C7FF	USART1
0x4000C000 – 0x4000C3FF	USART0
0x4000A400 – 0x4000BFFF	Reserved
0x4000A000 – 0x4000A3FF	I2C0
0x40008400 – 0x40009FFF	Reserved
0x40008000 – 0x400083FF	EBI
0x40007000 – 0x40007FFF	Reserved
0x40006000 – 0x40006FFF	GPIO
0x40004400 – 0x40005FFF	Reserved
0x40004000 – 0x400043FF	DAC0
0x40002400 – 0x40003FFF	Reserved
0x40002000 – 0x400023FF	ADC0
0x40001800 – 0x40001FFF	Reserved
0x40001400 – 0x400017FF	ACMP1
0x40001000 – 0x400013FF	ACMP0
0x40000400 – 0x40000FFF	Reserved
0x40000000 – 0x400003FF	VCMP

5.2.3 Bus Matrix

The Bus Matrix connects the memory segments to the bus masters:

- Code: CPU instruction or data fetches from the code space
- System: CPU read and write to the SRAM, EBI and peripherals
- DMA: Access to code space, SRAM, EBI and peripherals

5.2.3.1 Arbitration

The Bus Matrix uses a round-robin arbitration algorithm which enables high throughput and low latency while starvation of simultaneous accesses to the same bus slave are eliminated. Round-robin does not assign a fixed priority to each bus master. The arbiter does not insert any bus wait-states.

5.2.3.2 Access Performance

The Bus Matrix is a multi-layer energy optimized AMBA AHB compliant bus with an internal bandwidth of 4x a single AHB interface.

The Bus Matrix accepts new transfers to be initiated by each master in each cycle without inserting any wait-states. However, the slaves may insert wait-states depending on their internal throughput and the clock frequency.

The Cortex-M3 and the DMA Controller, and the peripherals (not peripherals in the low frequency clock domain) run on clocks which can be prescaled separately. When accessing a peripheral which runs on a frequency equal to or faster than the HFCORECLK, the number of wait cycles per access, in addition to master arbitration, is given by:

Memory Wait Cycles with Clock Equal or Faster than the HFCORECLK

$$N_{\text{cycles}} = 2 + N_{\text{slave cycles}} \quad (5.3)$$

where $N_{\text{slave cycles}}$ is the wait cycles introduced by the slave.

When accessing a peripheral which runs on a slower clock than the HFCORECLK, wait cycles are introduced to allow the transfer to complete on the peripheral clock. The number of wait cycles per access, in addition to master arbitration, is given by:

Memory Wait Cycles with Clock Slower than the CPU

$$N_{\text{cycles}} = (2 + N_{\text{slave cycles}}) \times f_{\text{HFCORECLK}}/f_{\text{HFPERCLK}} \quad (5.4)$$

where $N_{\text{slave cycles}}$ is the wait cycles introduced by the slave.

Clocks and prescaling are described in more detail in Chapter 11 (p. 92) .

5.3 Access to Low Energy Peripherals (Asynchronous Registers)

5.3.1 Introduction

The Low Energy Peripherals are capable of running when the high frequency oscillator and core system is powered off, i.e. in energy mode EM2 and in some cases also EM3. This enables the peripherals to perform tasks while the system energy consumption is minimal.

The Low Energy Peripherals are:

- Liquid Crystal Display driver - LCD
- Low Energy Timer - LETIMER
- Low Energy UART - LEUART
- Pulse Counter - PCNT
- Real Time Counter - RTC
- Watchdog - WDOG

All Low Energy Peripherals are memory mapped, with automatic data synchronization. Because the Low Energy Peripherals are running on clocks asynchronous to the core clock, there are some constraints on how register accesses are performed, as described in the following sections.

5.3.1.1 Writing

Every Low Energy Peripheral has one or more registers with data that needs to be synchronized into the Low Energy clock domain to maintain data consistency and predictable operation. Due to

synchronization, the write operation requires 3 positive edges of the clock of the Low Energy Peripheral being accessed. Such registers are marked "Asynchronous" in their description header.

See Figure 5.3 (p. 19) for an overview of the writing operation.

After writing data to a register which value is to be synchronized into the Low Energy clock domain, a corresponding busy flag in the <module_name>_SYNCBUSY register (e.g. RTC_SYNCBUSY) is set. This flag is set as long as synchronization is in progress and is cleared upon completion.

Note

Subsequent writes to the same register before the corresponding busy flag is cleared is not supported. Write before the busy flag is cleared may result in undefined behavior.

In general the SYNCBUSY register only needs to be observed if there is a risk of multiple write access to a register (which must be prevented). It is not required to wait until the relevant flag in the SYNCBUSY register is cleared after writing a register. E.g. can EM2 be entered directly after writing a register.

Figure 5.3. Write operation to Low Energy Peripherals

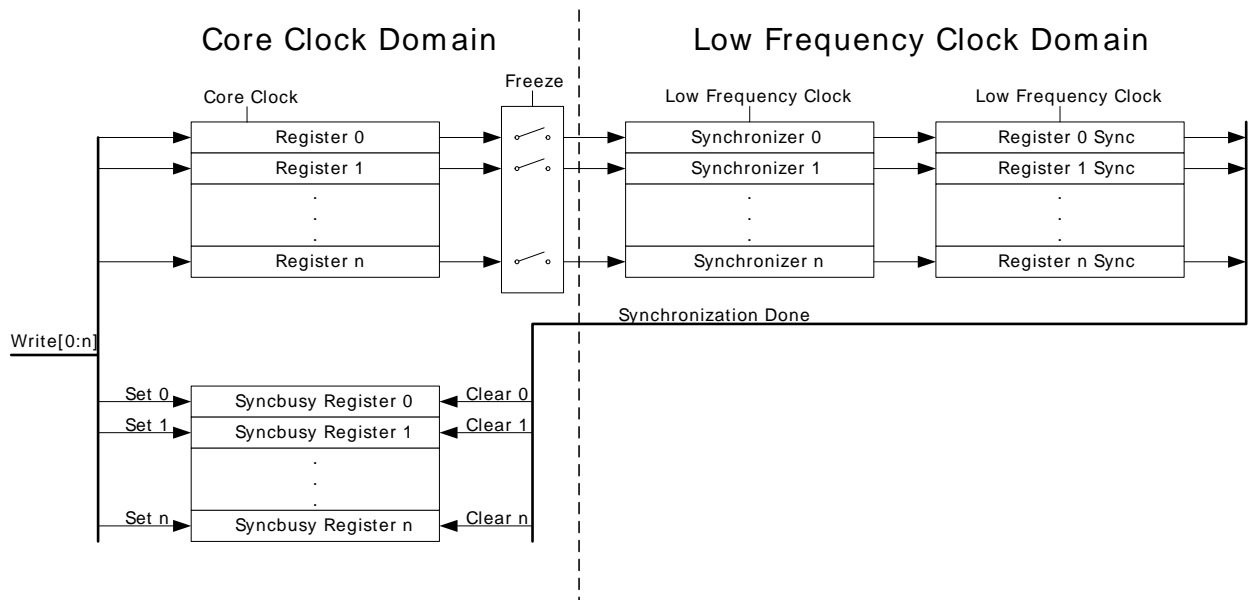

5.3.1.2 Reading

When reading from a Low Energy Peripheral, the data read is synchronized regardless if it originates in the Low Energy clock domain or core clock domain. Registers which are updated/ maintained by the Low Energy Peripheral are read directly from the Low Energy clock domain. Registers which originate in the core clock domain, are read from the core clock domain. See Figure 5.4 (p. 20) for an overview of the reading operation.

Note

Writing a register and then immediately reading the new value of the register may give the impression that the write operation is complete. This may not be the case. Please refer to the SYNCBUSY register for correct status of the write operation to the Low Energy Peripheral.

Figure 5.4. Read operation form Low Energy Peripherals

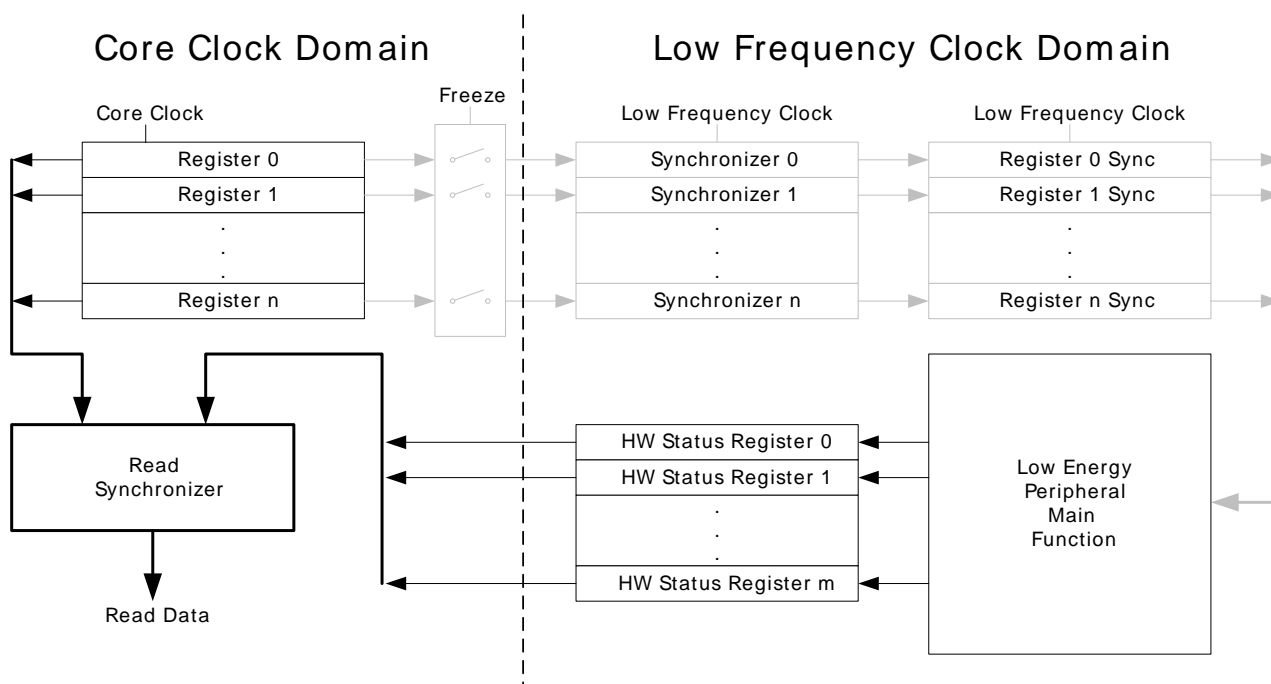

5.3.2 FREEZE register

In all Low Energy Peripheral there is a <module_name>_FREEZE register (e.g. RTC_FREEZE). The register contains a bit named REGFREEZE. If precise control of the synchronization process is required, this bit may be utilized. When REGFREEZE is set, the synchronization process is halted allowing the software to write multiple Low Energy registers before starting the synchronization process, thus providing precise control of the module update process. The synchronization process is started by clearing the REGFREEZE bit.

5.4 Flash

The Flash retains data in any state and typically stores the application code, special user data and security information. The Flash memory is typically programmed through the debug interface, but can also be erased and written to from software.

- Up to 128 KB of memory
- Page size of 512 bytes (minimum erase unit)
- Minimum 20K erase cycles endurance
- Greater than 10 years data retention at 85°C
- Lock-bits for memory protection
- Data retention in any state

5.5 SRAM

The primary task of the SRAM memory is to store application data. Additionally, it is possible to execute instructions from SRAM, and the DMA may be set up to transfer data between the SRAM, Flash and peripherals.

- Up to 16 KB memory
- Bit-band access support
- 4KB blocks may be individually powered down when not in use
- Data retention of the entire memory in EM0 to EM3

5.6 Device Information (DI) Page

The DI page contains calibration values, a unique identification number and other useful data. See the table below for a complete overview.

Table 5.4. Device Information Table

DI Address	Register	Description
0x0FE08020	CMU_LFRCCOCTRL	
0x0FE08028	CMU_HFRCCOCTRL	
0x0FE08030	CMU_AUXHFRCCOCTRL	
0x0FE08040	ADC0_CAL	
0x0FE08048	ADC0_BIASPROG	
0x0FE08050	DAC0_CAL	
0x0FE08058	DAC0_BIASPROG	
0x0FE08060	ACMP0_CTRL	
0x0FE08068	ACMP1_CTRL	
0x0FE08070	LCD_DISPCTRLX	
0x0FE08078	CMU_LCDCTRL	
0x0FE081B0	DI_CRC	[15:0]: DI data CRC-16
0x0FE081B2	CAL_TEMP_0	[7:0] Calibration temperature (DegC)
0x0FE081B3	RESERVED	[7:0]: Reserved for other temperature information
0x0FE081B4	ADC0_CAL_1V25	[14:8]: Gain for 1V25 reference [6:0]: Offset for 1V25 reference
0x0FE081B6	ADC0_CAL_2V5	[14:8]: Gain for 2V5 reference [6:0]: Offset for 2V5 reference
0x0FE081B8	ADC0_CAL_VDD	[14:8]: Gain for VDD reference [6:0]: Offset for VDD reference
0x0FE081BA	ADC0_CAL_5VDIFF	[14:8]: Gain for 5VDIFF reference [6:0]: Offset for 5VDIFF reference
0x0FE081BC	ADC0_CAL_2XVDDVSS	[14:8]: Reserved (gain for this reference cannot be calibrated) [6:0]: Offset for 2XVDDVSS reference
0x0FE081BE	ADC0_TEMP_0_READ_1V25	[15:4] Temperature reading at 1V25 reference [3:0] Reserved
0x0FE081C0	RESERVED	[15:0] Reserved for other temperature information
0x0FE081C2	RESERVED	[15:0] Reserved
0x0FE081C4	RESERVED	[31:0] Reserved
0x0FE081C8	DAC0_CAL_1V25	[22:16]: Gain for 1V25 reference [13:8]: Channel 1 offset for 1V25 reference [5:0]: Channel 0 offset for 1V25 reference
0x0FE081CC	DAC0_CAL_2V5	[22:16]: Gain for 2V5 reference [13:8]: Channel 1 offset for 2V5 reference [5:0]: Channel 0 offset for 2V5 reference
0x0FE081D0	DAC0_CAL_VDD	[22:16]: Reserved (gain for this reference cannot be calibrated) [13:8]: Channel 1 offset for VDD reference [5:0]: Channel 0 offset for VDD reference
0x0FE081D4	RESERVED	[31:0] Reserved
0x0FE081D8	RESERVED	[31:0] Reserved

DI Address	Register	Description
0x0FE081DC	HFRCO_CALIB_BAND_1	[7:0]: 1 MHz tuning
0x0FE081DD	HFRCO_CALIB_BAND_7	[7:0]: 7 MHz tuning
0x0FE081DE	HFRCO_CALIB_BAND_11	[7:0]: 11 MHz tuning
0x0FE081DF	HFRCO_CALIB_BAND_14	[7:0]: 14 MHz tuning
0x0FE081E0	HFRCO_CALIB_BAND_21	[7:0]: 21 MHz tuning
0x0FE081E1	HFRCO_CALIB_BAND_28	[7:0]: 28 MHz tuning
0x0FE081E2	RESERVED	[15:0] Reserved
0x0FE081E4	RESERVED	[31:0] Reserved
0x0FE081F0	UNIQUE_0	[31:0] Unique number
0x0FE081F4	UNIQUE_1	[63:32] Unique number
0x0FE081F8	MEM_INFO_FLASH	[15:0]: Flash size, kbyte count as unsigned integer (eg. 128)
0x0FE081FA	MEM_INFO_RAM	[15:0]: Ram size, kbyte count as unsigned integer (eg. 16)
0x0FE081FC	PART_NUMBER	[15:0]: EFM32 part number as unsigned integer (eg. 230)
0x0FE081FE	PART_FAMILY	[7:0]: EFM32 part family number (Gecko = 71d)
0x0FE081FF	PROD_REV	[7:0]: EFM32 Production ID

6 DBG - Debug Interface

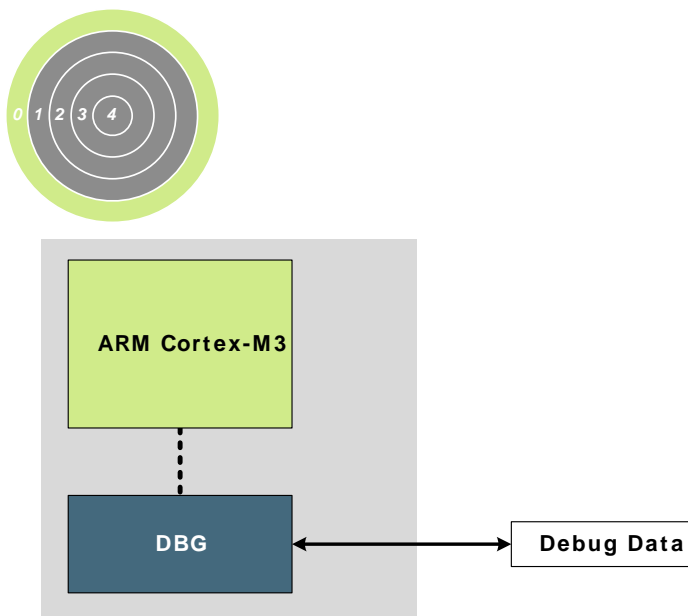

Quick Facts

What?

The DBG (Debug Interface) is used to program and debug EFM32G devices.

Why?

The Debug Interface makes it easy to re-program and update the system in field, and allows debugging with minimal I/O pin use.

How?

The Cortex-M3 supports advanced debugging features. EFM32G devices only use two port pins for debugging or programming. The systems internal and external state can be examined with debug extensions supporting instruction or data access break- and watch points.

6.1 Introduction

The EFM32G devices include hardware debug support through a 2-pin serial-wire debug interface. In addition there is also a 1-wire Serial Wire Viewer pin which can be used to output profiling information, data trace and software-generated messages.

6.2 Features

- Flash Patch and Breakpoint (FPB) unit
 - Implement breakpoints and code patches
- Data Watch point and Trace (DWT) unit
 - Implement watch points, trigger resources, and system profiling
- Instrumentation Trace Macrocell (ITM)
 - Application-driven trace source that supports printf style debugging

6.3 Functional Description

There are three debug pins on the device, which also can be used as GPIO. The three debug pins are:

- SWCLK Serial Wire Clock input. This pin is enabled after reset and has a built-in pull down.
- SWDIO Serial Wire data Input/Output. This pin is enabled after a reset and has a built in pull-up.
- SWO Serial Wire Viewer Output. This pin is disabled after a reset.

For more information on how to enable the debug pin outputs/inputs the reader is referred to Section 28.3.2.1 (p. 397) , the ARM Cortex-M3 Technical Reference Manual and the ARM CoreSight Technical Reference Manual

6.4 Debug Lock and Device Erase

The debug access to the Cortex-M3 is locked by clearing the Debug Lock Word (DLW), see Section 7.3.2 (p. 29)

When debug access is locked, the debug interface remains accessible, but the connection to the Cortex-M3 core is blocked. This mechanism is controlled by the Authentication Access Port (AAP) as illustrated by Figure 6.1 (p. 24) .

Figure 6.1. AAP - Authentication Access Port

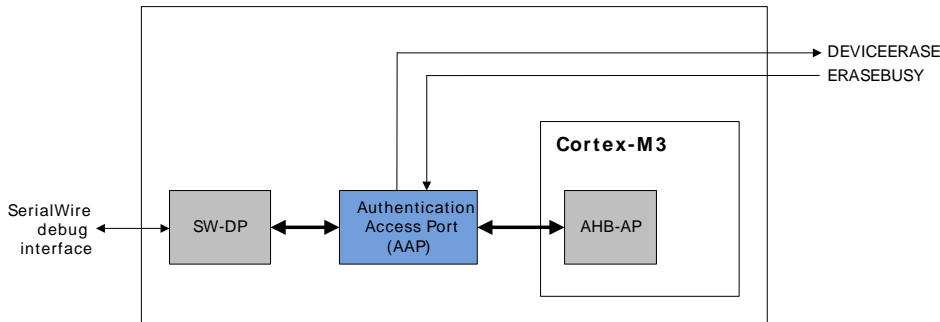

The device is unlocked by writing to the AAP_CMDKEY register and then setting the DEVICEERASE bit of the AAP_CMD register via the debug interface. This erase operation erases the main block, all lock bits are reset and debug access through the AHB-AP is enabled. The operation takes 40 ms to complete. Note that the SRAM contents will also be deleted during a device erase.

The debugger may read the status from the AAP_STATUS register. When the ERASEBUSY bit is set low after DEVICEERASE of the AAP_CMD register is set, the debugger may set the SYSRESETREQ bit in the AAP_CMD register. After reset, the debugger may resume a normal debug session through the AHB-AP.

Note

If the debug pins are reconfigured for other I/O purposes than debug, a device erase may no longer be executed. The pins are configured for debug in their reset state.

6.5 Register Map

The offset register address is relative to the registers base address.

Offset	Name	Type	Description
0x000	AAP_CMD	W1	Command Register
0x004	AAP_CMDKEY	W1	Command Key Register
0x008	AAP_STATUS	R	Status Register
0x0FC	AAP_IDR	R	AAP Identification Register

6.6 Register Description

6.6.1 AAP_CMD - Command Register

Offset	Bit Position																															
0x000	31	30	29	28	27	26	25	24	23	22	21	20	19	18	17	16	15	14	13	12	11	10	9	8	7	6	5	4	3	2	1	0
Reset																															0	0
Access																															W1	W1
Name																															SYSRESETREQ	DEVICEERASE

Bit	Name	Reset	Access	Description
31:2	<i>Reserved</i>	<i>To ensure compatibility with future devices, always write bits to 0. More information in Section 2.1 (p. 3)</i>		
1	SYSRESETREQ	0	W1	System Reset Request A system reset request is generated when set to 1. This register is write enabled from the AAP_CMDKEY register.
0	DEVICEERASE	0	W1	Erase the Flash Main Block, SRAM and Lock Bits When set, all data and program code in the main block is erased, the SRAM is cleared and then the Lock bit (LB) page is erased. This also includes the Debug lock word (DLW), causing debug access to be enabled after the next reset. The information block user data page (UD) is left unchanged, but the User data page lock word (ULW) is erased. This register is write enabled from the AAP_CMDKEY register.

6.6.2 AAP_CMDKEY - Command Key Register

Offset	Bit Position																															
0x004	31	30	29	28	27	26	25	24	23	22	21	20	19	18	17	16	15	14	13	12	11	10	9	8	7	6	5	4	3	2	1	0
Reset																															0x00000000	
Access																															W1	
Name																															WRITEKEY	

Bit	Name	Reset	Access	Description
31:0	WRITEKEY	0x00000000	W1	CMD Key Register

Bit	Name	Reset	Access	Description
The key value must be written to this register to write enable the AAP_CMD register.				
	Value	Mode	Description	
	0xCFACC118	WRITEEN	Enable write to AAP_CMD	

6.6.3 AAP_STATUS - Status Register

Offset	Bit Position																															
0x008	31	30	29	28	27	26	25	24	23	22	21	20	19	18	17	16	15	14	13	12	11	10	9	8	7	6	5	4	3	2	1	0
Reset																																0
Access																																R
Name																																ERASEBUSY

Bit	Name	Reset	Access	Description
31:1	Reserved	To ensure compatibility with future devices, always write bits to 0. More information in Section 2.1 (p. 3)		
0	ERASEBUSY	0	R	Device Erase Command Status This bit is set when a device erase is executing.

6.6.4 AAP_IDR - AAP Identification Register

Offset	Bit Position																															
0x0FC	31	30	29	28	27	26	25	24	23	22	21	20	19	18	17	16	15	14	13	12	11	10	9	8	7	6	5	4	3	2	1	0
Reset																																0x16E60001
Access																																R
Name																																ID

Bit	Name	Reset	Access	Description
31:0	ID	0x16E60001	R	AAP Identification Register Access port identification register in compliance with the ARM ADI v5 specification (JEDEC Manufacturer ID) .

7 MSC - Memory System Controller

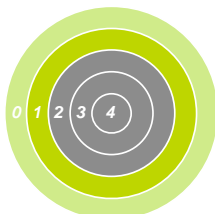

```

01000101011011100110010101110010
01100111011110010010000001001101
01101001011000110111001001101111
00100000011100100111010101101100
01100101011100110010000001110100
01101000011001010010000001110111
01101111011100100110110001100100
00100000011011110110011000100000
01101100011011110111011100101101
01100101011011100110010101110010
01100111011110010010000001101101
01101001011000110111001001101111
01100011011011110110111001110100
01110010011011110110110001101100
01100101011100100010000001100100
01100101011100110110100101100111
01101110001000010100010101101110
    
```

Quick Facts

What?

The user can perform Flash memory read, read configuration and write operations through the Memory System Controller (MSC) .

Why?

The MSC allows the application code, user data and flash lock bits to be stored in non-volatile Flash memory. Certain memory system functions, such as program memory wait-states and bus faults are also configured from the MSC peripheral register interface, giving the developer the ability to dynamically customize the memory system performance, security level, energy consumption and error handling capabilities to the requirements at hand.

How?

The MSC integrates a low-energy Flash IP with a charge pump, enabling minimum energy consumption while eliminating the need for external programming voltage to erase the memory. An easy to use write and erase interface is supported by an internal, fixed-frequency oscillator and autonomous flash timing and control reduces software complexity while not using other timer resources.

Application code may dynamically scale between high energy optimization and high code execution performance through advanced read modes.

7.1 Introduction

The Memory System Controller (MSC) is the program memory unit of the EFM32G microcontroller. The flash memory is readable and writable from both the Cortex-M3 and DMA. The flash memory is divided into two blocks; the main block and the information block. Program code is normally written to the main block. Additionally, the information block is available for special user data and flash lock bits. There is also a read-only page in the information block containing system and device calibration data. Read and write operations are supported in the energy modes EM0 and EM1.

7.2 Features

- AHB read interface
 - Scalable access performance to optimize the Cortex-M3 code interface
 - Zero wait-state access up to 16 MHz and one wait-state for 16 MHz and above
 - Advanced energy optimization functionality

- Conditional branch target prefetch suppression
- Cortex-M3 unfolding of if-then (IT) blocks
- DMA read support in EM0 and EM1
- Command and status interface
 - Flash write and erase
 - Accessible from Cortex-M3 in EM0
 - DMA write support in EM0 and EM1
- Core clock independent Flash timing
 - Internal oscillator and internal timers for precise and autonomous Flash timing
 - General purpose timers are not occupied during Flash erase and write operations
 - Need for special time scaling registers eliminated
- Configurable interrupt erase abort
 - Improved interrupt predictability
- Memory and bus fault control
- Security features
 - Lockable debug access
 - Page lock bits
- End-of-write and end-of-erase interrupts

7.3 Functional Description

The size of the main block is device dependent. The largest size available is 128 KB (256 pages). The information block is fixed in size for all devices with 512 bytes available for user data. The information block also contains chip configuration data located in a reserved area. The main block is mapped to address 0x00000000 and the information block is mapped to address 0x0FE00000. Table 7.1 (p. 28) outlines how the Flash is mapped in the memory space. All Flash memory is organized into 512 byte pages.

Table 7.1. MSC Flash Memory Mapping

Block	Page	Base address	Write/Erase by	Software readable	Purpose/Name	Size
Main ¹	0	0x00000000	Software, debug	Yes	User code and data	16 KB - 128 KB
	.		Software, debug	Yes		
	255	0x0001FF00	Software, debug	Yes		
Reserved	-	0x00020000	-	-	Reserved for flash expansion	~24 MB
Information	0	0x0FE00000	Software, debug	Yes	User Data (UD)	2 KB/64 KB
	-	0x0FE00200	-	-	Reserved	
	1	0x0FE04000	Debug only	Yes	Lock Bits (LB)	
	-	0x0FE04200	-	-	Reserved	
	2	0x0FE08000	-	Yes	Device Information (DI)	
	-	0x0FE08200	-	-	Reserved	
Reserved	-	0x0FE10000	-	-	Reserved for flash expansion	Rest of code space

¹Block/page erased by a device erase

7.3.1 User Data (UD) Page Description

This is the user data page in the information block. The page can be erased and written by software. The page is erased by the ERASEPAGE command of the MSC_WRITECMD register. Note that the page is not erased by a device erase operation. The device erase operation is described in Section 6.4 (p. 23) .

7.3.2 Lock Bits (LB) Page Description

This page contains the following information:

- Main block Page Lock Words (PLWs)
- User data page Lock Word (ULWs)
- Debug Lock Word (DLW)

The words in this page are organized as shown in Table 7.2 (p. 29) :

Table 7.2. Lock Bits Page Structure

127	DLW
126	ULW
N	PLW[N]
...	...
1	PLW[1]
0	PLW[0]

There are 32 page lock bits per page lock word (PLW). Bit 0 refers to the first page and bit 31 refers to the last page within a PLW. Thus, PLW[0] contains lock bits for page 0-31 in the main block, PLW[1] contains lock bits for page 32-63 etc. A page is locked when the bit is 0. A locked page cannot be erased or written.

Note

Trying to write to a locked page before writing to a page which is not locked will write the data that was attempted to write in the locked page. The recommended procedure is to perform the write twice.

Word 127 is the debug lock word (DLW). Bit 0 of this word is the debug lock bit. If this bit is 1, then debug access is enabled. Debug access to the core is disabled from power-on reset until the DLW is evaluated immediately before the Cortex-M3 starts execution of the user application code. If the bit is 0, then debug access to the core remains blocked.

Word 126 is the user page lock word (ULW). Bit 0 of this word is the page lock bit. The lock bits can be reset by a device erase operation initiated from the Authentication Access Port (AAP) registers. The AAP is described in more detail in Section 6.4 (p. 23) . Note that the AAP is only accessible from the debug interface, and cannot be accessed from the Cortex-M3 core.

7.3.3 Device Information (DI) Page

This read-only page holds oscillator, DAC and ADC calibration data from the production test as well as an unique device ID. The page is further described in Section 5.6 (p. 21) .

7.3.4 Device Revision

The device revision number is read from the ROM Table. The Revision number is extracted from the PID2 and PID3 registers, as illustrated in Figure 7.1 (p. 30) .The Rev[7:4] and Rev[3:0] must be combined to form the complete revision number Revision[7:0].

Figure 7.1. Revision Number Extraction

PID2 (0xE00FFE8)			PID3 (0xE00FFEC)		
31:8	7:4	3:0	31:8	7:4	3:0
	Rev[7:4]			Rev[3:0]	

The Revision number is to be interpreted according to Table 7.3 (p. 30) .

Table 7.3. Revision Number Interpretation

Revision[7:0]	Revision
0x00	A
0x01	B
0x02	C

7.3.5 Post-reset Behavior

Calibration values are automatically written to registers by the MSC before application code startup. The values are also available to read from the DI page for later reference by software. Other information such as the device ID and production date is also stored in the DI page and is readable from software.

7.3.5.1 One Wait-state Access

After reset, the HFCORECLK is normally 14 MHz from the HFRCO and the MODE field of the MSC_READCTRL register is set to WS1 (one wait-state). The reset value must be WS1 as an uncalibrated HFRCO may produce a frequency higher than 16 MHz. Software must not select a zero wait-state mode unless the clock is guaranteed to be 16 MHz or below, otherwise the resulting behavior is undefined. If a HFCORECLK frequency above 16 MHz is to be set by software, the MODE field of the MSC_READCTRL register must be set to WS1 or WS1SCBTP before the core clock is switched to the higher frequency clock source.

When changing to a lower frequency, the MODE field of the MSC_READCTRL register must be set to WS0 or WS0SCBTP only after the frequency transition has completed. If the HFRCO is used, wait until the oscillator is stable on the new frequency. Otherwise, the behavior is unpredictable.

7.3.5.2 Zero Wait-state Access

At 16 MHz and below, read operations from flash may be performed without any wait-states. Zero wait-state access greatly improves code execution performance at frequencies from 16 MHz and below. By default, the Cortex-M3 uses speculative prefetching and If-Then block folding to maximize code execution performance at the cost of additional flash accesses and energy consumption.

7.3.5.3 Suppressed Conditional Branch Target Prefetch (SCBTP)

MSC offers a special instruction fetch mode which optimizes energy consumption by cancelling Cortex-M3 conditional branch target prefetches. Normally, the Cortex-M3 core prefetches both the next sequential instruction and the instruction at the branch target address when a conditional branch instruction reaches the pipeline decode stage. This prefetch scheme improves performance while one extra instruction is fetched from memory at each conditional branch, regardless of whether the branch is taken or not. To optimize for low energy, the MSC can be configured to cancel these speculative branch target prefetches. With this configuration, energy consumption is more optimal, as the branch target instruction fetch is delayed until the branch condition is evaluated.

The performance penalty with this mode enabled is source code dependent, but is normally less than 1% for core frequencies from 16 MHz and below. To enable the mode at frequencies from 16 MHz and below write WS0SCBTP to the MODE field of the MSC_READCTRL register. For frequencies above 16 MHz, use the WS1SCBTP mode. An increased performance penalty per clock cycle must be expected

in this mode compared to WS0SCBTP mode. The performance penalty in WS1SCBTP mode depends greatly on the density and organization of conditional branch instructions in the code.

7.3.5.4 Cortex-M3 If-Then Block Folding

The Cortex-M3 offers a mechanism known as if-then block folding. This is a form of speculative prefetching where small if-then blocks are collapsed in the prefetch buffer if the condition evaluates to false. The instructions in the block then appear to execute in zero cycles. With this scheme, performance is optimized at the cost of higher energy consumption as the processor fetches more instructions from memory than it actually executes. To disable the mode, write a 1 to the DISFOLD bit in the NVIC Auxiliary Control Register; see the Cortex-M3 Technical Reference Manual for details. Normally, it is expected that this feature is most efficient at core frequencies above 16 MHz. Folding is enabled by default.

7.3.6 Erase and Write Operations

Both page erase and write operations require that the address is written into the MSC_ADDRB register. For erase operations, the address may be any within the page to be erased. Load the address by writing 1 to the LADDRIM bit in the MSC_WRITECMD register. The LADDRIM bit only has to be written once when loading the first address. After each word is written the internal address register ADDR will be incremented automatically by 4. The INVADDR bit of the MSC_STATUS register is set if the loaded address is outside the flash and the LOCKED bit of the MSC_STATUS register is set if the page addressed is locked. Any attempts to command erase of or write to the page are ignored if INVADDR or the LOCKED bits of the MSC_STATUS register are set.

When a word is written to the MSC_WDATA register, the WDATABREADY bit of the MSC_STATUS register is cleared. When this status bit is set, software or DMA may write the next word.

A single word write is commanded by setting the WRITEONCE bit of the MSC_WRITECMD register. The operation is complete when the BUSY bit of the MSC_STATUS register is cleared and control of the flash is handed back to the AHB interface, allowing application code to resume execution.

For a DMA write the software must write the first word to the MSC_WDATA register and then set the WRITETRIG bit of the MSC_WRITECMD register. DMA triggers when the WDATABREADY bit of the MSC_STATUS register is set.

It is possible to write words twice between each erase by keeping at 1 the bits that are not to be changed. Let us take as an example writing two 16 bit values, 0xAAAA and 0x5555. To safely write them in the same flash word this method can be used:

- Write 0xFFFFAAAA (word in flash becomes 0xFFFFAAAA)
- Write 0x5555FFFF (word in flash becomes 0x5555AAAA)

Note

The WRITEONCE, WRITETRIG and ERASEPAGE bits in the MSC_WRITECMD register cannot safely be written from code in Flash. It is recommended to place a small code section in RAM to set these bits and wait for the operation to complete. Also note that DMA transfers to or from any other address in Flash while a write or erase operation is in progress will produce unpredictable results.

7.4 Register Map

The offset register address is relative to the registers base address.

Offset	Name	Type	Description
0x000	MSC_CTRL	RW	Memory System Control Register
0x004	MSC_READCTRL	RW	Read Control Register
0x008	MSC_WRITECTRL	RW	Write Control Register
0x00C	MSC_WRITECMD	W1	Write Command Register
0x010	MSC_ADDRB	RW	Page Erase/Write Address Buffer
0x018	MSC_WDATA	RW	Write Data Register
0x01C	MSC_STATUS	R	Status Register
0x02C	MSC_IF	R	Interrupt Flag Register
0x030	MSC_IFS	W1	Interrupt Flag Set Register
0x034	MSC_IFC	W1	Interrupt Flag Clear Register
0x038	MSC_IEN	RW	Interrupt Enable Register
0x03C	MSC_LOCK	RW	Configuration Lock Register

7.5 Register Description

7.5.1 MSC_CTRL - Memory System Control Register

Offset	Bit Position																															
0x000	31	30	29	28	27	26	25	24	23	22	21	20	19	18	17	16	15	14	13	12	11	10	9	8	7	6	5	4	3	2	1	0
Reset																																1
Access																																RW
Name																																BUSFAULT

Bit	Name	Reset	Access	Description
31:1	Reserved	To ensure compatibility with future devices, always write bits to 0. More information in Section 2.1 (p. 3)		

0	BUSFAULT	1	RW	Bus Fault Response Enable When this bit is set, the memory system generates bus error response
	Value	Mode	Description	
	0	GENERATE	A bus fault is generated on access to unmapped code and system space	
	1	IGNORE	Accesses to unmapped address space is ignored	

7.5.2 MSC_READCTRL - Read Control Register

Offset	Bit Position																															
0x004	31	30	29	28	27	26	25	24	23	22	21	20	19	18	17	16	15	14	13	12	11	10	9	8	7	6	5	4	3	2	1	0
Reset																																0x1
Access																																RW
Name																																MODE

Bit	Name	Reset	Access	Description															
31:3	Reserved	To ensure compatibility with future devices, always write bits to 0. More information in Section 2.1 (p. 3)																	
2:0	MODE	0x1	RW	Read Mode															
<p>After reset, the core clock is 14 MHz from the HFRCO and the MODE field of MSC_READCTRL register is set to WS1. The reset value is WS1 because the HFRCO may produce a frequency above 16 MHz before it is calibrated. WS1 or WS1SCBTP mode is required for a frequency above 16 MHz. If software wants to set a core clock frequency above 16 MHz, this register must be set to WS1 or WS1SCBTP before the core clock is switched to the higher frequency. When changing to a lower frequency, this register can be set to WS0 or WS0SCBTP after the frequency transition has been completed. If the HFRCO is used as clock source, wait until the oscillator is stable on the new frequency to avoid unpredictable behavior.</p>																			
<table border="1"> <thead> <tr> <th>Value</th> <th>Mode</th> <th>Description</th> </tr> </thead> <tbody> <tr> <td>0</td> <td>WS0</td> <td>Zero wait-states inserted in fetch or read transfers</td> </tr> <tr> <td>1</td> <td>WS1</td> <td>One wait-state inserted for each fetch or read transfer. This mode is required for a core frequency above 16 MHz.</td> </tr> <tr> <td>2</td> <td>WS0SCBTP</td> <td>Zero wait-states inserted with the Suppressed Conditional Branch Target Prefetch (SCBTP) function enabled. SCBTP saves energy by delaying Cortex-M3 conditional branch target prefetches until the conditional branch instruction is in the execute stage. When the instruction reaches this stage, the evaluation of the branch condition is completed and the core does not perform a speculative prefetch of both the branch target address and the next sequential address. With the SCBTP function enabled, one instruction fetch is saved for each branch not taken, with a negligible performance penalty.</td> </tr> <tr> <td>3</td> <td>WS1SCBTP</td> <td>One wait-state access with SCBTP enabled.</td> </tr> </tbody> </table>					Value	Mode	Description	0	WS0	Zero wait-states inserted in fetch or read transfers	1	WS1	One wait-state inserted for each fetch or read transfer. This mode is required for a core frequency above 16 MHz.	2	WS0SCBTP	Zero wait-states inserted with the Suppressed Conditional Branch Target Prefetch (SCBTP) function enabled. SCBTP saves energy by delaying Cortex-M3 conditional branch target prefetches until the conditional branch instruction is in the execute stage. When the instruction reaches this stage, the evaluation of the branch condition is completed and the core does not perform a speculative prefetch of both the branch target address and the next sequential address. With the SCBTP function enabled, one instruction fetch is saved for each branch not taken, with a negligible performance penalty.	3	WS1SCBTP	One wait-state access with SCBTP enabled.
Value	Mode	Description																	
0	WS0	Zero wait-states inserted in fetch or read transfers																	
1	WS1	One wait-state inserted for each fetch or read transfer. This mode is required for a core frequency above 16 MHz.																	
2	WS0SCBTP	Zero wait-states inserted with the Suppressed Conditional Branch Target Prefetch (SCBTP) function enabled. SCBTP saves energy by delaying Cortex-M3 conditional branch target prefetches until the conditional branch instruction is in the execute stage. When the instruction reaches this stage, the evaluation of the branch condition is completed and the core does not perform a speculative prefetch of both the branch target address and the next sequential address. With the SCBTP function enabled, one instruction fetch is saved for each branch not taken, with a negligible performance penalty.																	
3	WS1SCBTP	One wait-state access with SCBTP enabled.																	

7.5.3 MSC_WRITECTRL - Write Control Register

Offset	Bit Position																															
0x008	31	30	29	28	27	26	25	24	23	22	21	20	19	18	17	16	15	14	13	12	11	10	9	8	7	6	5	4	3	2	1	0
Reset																															0	0
Access																															RW	RW
Name																															IRQERASEABORT	WREN

Bit	Name	Reset	Access	Description
31:2	Reserved	To ensure compatibility with future devices, always write bits to 0. More information in Section 2.1 (p. 3)		
1	IRQERASEABORT	0	RW	Abort Page Erase on Interrupt
<p>When this bit is set to 1, any Cortex-M3 interrupt aborts any current page erase operation. If the CPU reads the interrupt vectors from Flash in this case, the CPU can enter an unpredictable state. This can be avoided by moving the interrupt vectors to RAM.</p>				
0	WREN	0	RW	Enable Write/Erase Controller
<p>When this bit is set, the MSC write and erase functionality is enabled</p>				

7.5.4 MSC_WRITECMD - Write Command Register

Offset	Bit Position																															
0x00C	31	30	29	28	27	26	25	24	23	22	21	20	19	18	17	16	15	14	13	12	11	10	9	8	7	6	5	4	3	2	1	0
Reset																					0	0	0	0	0							
Access																					W1	W1	W1	W1	W1							
Name																					WRITETRIG	WRITEONCE	WRITEEND	ERASEPAGE	LADDRIM							

Bit	Name	Reset	Access	Description
31:5	Reserved	To ensure compatibility with future devices, always write bits to 0. More information in Section 2.1 (p. 3)		
4	WRITETRIG	0	W1	Word Write Sequence Trigger Start write of the first word written to MSC_WDATA, then add 4 to ADDR and write the next word if available within a 30us timeout. When ADDR is incremented past the page boundary, ADDR is set to the base of the page.
3	WRITEONCE	0	W1	Word Write-Once Trigger Write the word in MSC_WDATA to ADDR. Flash access is returned to the AHB interface as soon as the write operation completes. The WREN bit in the MSC_WRITECTRL register must be set in order to use this command.
2	WRITEEND	0	W1	End Write Mode Write 1 to end write mode when using the WRITETRIG command.
1	ERASEPAGE	0	W1	Erase Page Erase any user defined page selected by the MSC_ADDRB register. The WREN bit in the MSC_WRITECTRL register must be set in order to use this command.
0	LADDRIM	0	W1	Load MSC_ADDRB into ADDR Load the internal write address register ADDR from the MSC_ADDRB register. The internal address register ADDR is incremented automatically by 4 after each word is written. When ADDR is incremented past the page boundary, ADDR is set to the base of the page.

7.5.5 MSC_ADDRB - Page Erase/Write Address Buffer

Offset	Bit Position																																
0x010	31	30	29	28	27	26	25	24	23	22	21	20	19	18	17	16	15	14	13	12	11	10	9	8	7	6	5	4	3	2	1	0	
Reset																	0x00000000																
Access																	RW																
Name																	ADDRB																

Bit	Name	Reset	Access	Description
31:0	ADDRB	0x00000000	RW	Page Erase or Write Address Buffer This register holds the page address for the erase or write operation. As a page is 512 bytes, bit [8:0] of this register are ignored for erase commands. For write commands, bit [1:0] are ignored as writes are 32-bit wide only. This register is loaded into the internal MSC_ADDR register when the LADDRIM field in MSC_CMD is set. The MSC_ADDR register is not readable.

7.5.6 MSC_WDATA - Write Data Register

Offset	Bit Position																																
0x018	31	30	29	28	27	26	25	24	23	22	21	20	19	18	17	16	15	14	13	12	11	10	9	8	7	6	5	4	3	2	1	0	
Reset																	0x00000000																
Access																	RW																
Name																	WDATA																

Bit	Name	Reset	Access	Description
1	WRITE Set when a write is done	0	R	Write Done Interrupt Read Flag
0	ERASE Set when erase is done	0	R	Erase Done Interrupt Read Flag

7.5.9 MSC_IFS - Interrupt Flag Set Register

Offset	Bit Position																															
0x030	31	30	29	28	27	26	25	24	23	22	21	20	19	18	17	16	15	14	13	12	11	10	9	8	7	6	5	4	3	2	1	0
Reset																															0	0
Access																															W1	W1
Name																															WRITE	ERASE

Bit	Name	Reset	Access	Description
31:2	<i>Reserved</i>	<i>To ensure compatibility with future devices, always write bits to 0. More information in Section 2.1 (p. 3)</i>		
1	WRITE Set the write done bit and generate interrupt	0	W1	Write Done Interrupt Set
0	ERASE Set the erase done bit and generate interrupt	0	W1	Erase Done Interrupt Set

7.5.10 MSC_IFC - Interrupt Flag Clear Register

Offset	Bit Position																															
0x034	31	30	29	28	27	26	25	24	23	22	21	20	19	18	17	16	15	14	13	12	11	10	9	8	7	6	5	4	3	2	1	0
Reset																															0	0
Access																															W1	W1
Name																															WRITE	ERASE

Bit	Name	Reset	Access	Description
31:2	<i>Reserved</i>	<i>To ensure compatibility with future devices, always write bits to 0. More information in Section 2.1 (p. 3)</i>		
1	WRITE Clear the write done bit	0	W1	Write Done Interrupt Clear
0	ERASE Clear the erase done bit	0	W1	Erase Done Interrupt Clear

7.5.11 MSC_IEN - Interrupt Enable Register

Offset	Bit Position																															
0x038	31	30	29	28	27	26	25	24	23	22	21	20	19	18	17	16	15	14	13	12	11	10	9	8	7	6	5	4	3	2	1	0
Reset																															0	0
Access																															RW	RW
Name																															WRITE	ERASE

Bit	Name	Reset	Access	Description
31:2	Reserved	To ensure compatibility with future devices, always write bits to 0. More information in Section 2.1 (p. 3)		
1	WRITE Enable the write done interrupt	0	RW	Write Done Interrupt Enable
0	ERASE Enable the erase done interrupt	0	RW	Erase Done Interrupt Enable

7.5.12 MSC_LOCK - Configuration Lock Register

Offset	Bit Position																															
0x03C	31	30	29	28	27	26	25	24	23	22	21	20	19	18	17	16	15	14	13	12	11	10	9	8	7	6	5	4	3	2	1	0
Reset																															0x0000	
Access																															RW	
Name																															LOCKKEY	

Bit	Name	Reset	Access	Description
31:16	Reserved	To ensure compatibility with future devices, always write bits to 0. More information in Section 2.1 (p. 3)		
15:0	LOCKKEY Configuration Lock	0x0000	RW	

Write any other value than the unlock code to lock access to MSC_CTRL, MSC_READCTRL and MSC_WRITECTRL. Write the unlock code to enable access. When reading the register, bit 0 is set when the lock is enabled.

Mode	Value	Description
Read Operation		
UNLOCKED	0	MSC registers are unlocked
LOCKED	1	MSC registers are locked
Write Operation		
LOCK	0	Lock MSC registers
UNLOCK	0x1B71	Unlock MSC registers

8 DMA - DMA Controller

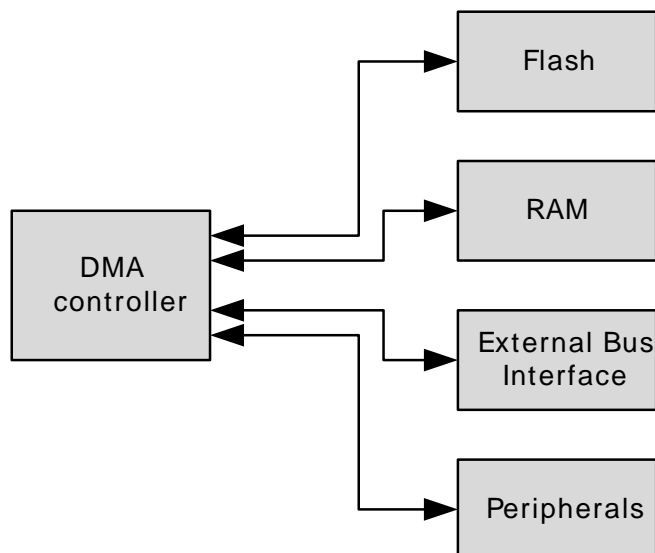
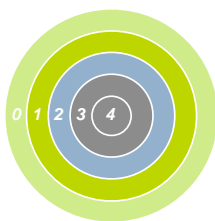

Quick Facts

What?

The DMA controller can move data without CPU intervention, effectively reducing the energy consumption for a data transfer.

Why?

The DMA can perform data transfers more energy efficiently than the CPU and allows autonomous operation in low energy modes. The LEUART can for instance provide full UART communication in EM2, consuming only a few μA by using the DMA to move data between the LEUART and RAM.

How?

The DMA controller has multiple highly configurable, prioritized DMA channels. Advanced transfer modes such as ping-pong and scatter-gather make it possible to tailor the controller to the specific needs of an application.

8.1 Introduction

The Direct Memory Access (DMA) controller performs memory operations independently of the CPU. This has the benefit of reducing the energy consumption and the workload of the CPU, and enables the system to stay in low energy modes when moving for instance data from the USART to RAM or from the External Bus Interface to the DAC. The DMA controller uses the PL230 μDMA controller licensed from ARM¹. Each of the PL230s channels can on the EFM32 be connected to any of the EFM32 peripherals.

8.2 Features

- The DMA controller is accessible as a memory mapped peripheral
- Possible data transfers include
 - RAM/External Bus Interface/Flash to peripheral
 - Peripheral to RAM/External Bus Interface
 - RAM/External Bus Interface /Flash to RAM/External Bus Interface
- The DMA controller has 8 independent channels
- Each channel has one (primary) or two (primary and alternate) descriptors
- The configuration for each channel includes
 - Transfer mode
 - Priority
 - Word-count
 - Word-size (8, 16, 32 bit)
- The transfer modes include
 - Basic (using the primary or alternate DMA descriptor)
 - Ping-pong (switching between the primary or alternate DMA descriptors, for continuous data flow to/from peripherals)

¹ARM PL230 homepage [<http://infocenter.arm.com/help/index.jsp?topic=/com.arm.doc.ddi0417a/index.html>]

- Scatter-gather (using the primary descriptor to configure the alternate descriptor)
- Each channel has a programmable transfer length
- A DMA channel can be triggered by any of several sources:
 - Communication modules (USART, UART, LEUART)
 - Timers (TIMER)
 - Analog modules (DAC, ADC)
 - Software
- Programmable mapping between channel number and peripherals - any DMA channel can be triggered by any of the available sources
- Interrupts upon transfer completion
- Data transfer to/from LEUART in EM2 is supported by the DMA, providing extremely low energy consumption while performing UART communications

8.3 Block Diagram

An overview of the DMA and the modules it interacts with is shown in Figure 8.1 (p. 39) .

Figure 8.1. DMA Block Diagram

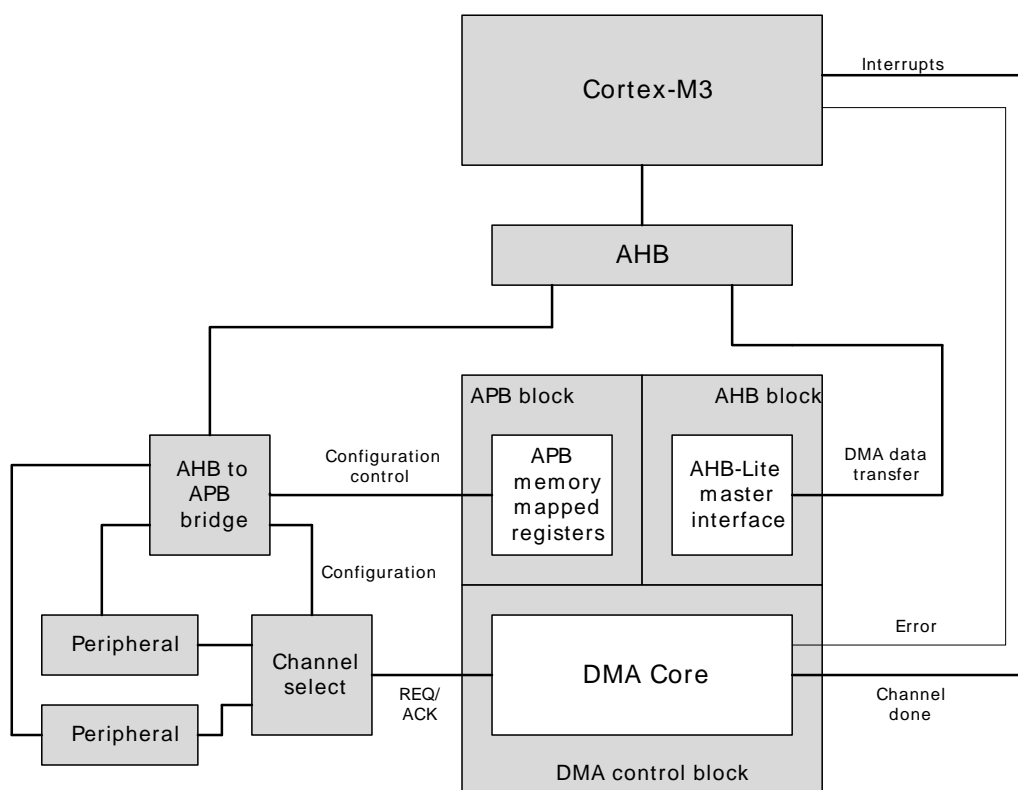

The DMA Controller consists of four main parts:

- An APB block allowing software to configure the DMA controller
- An AHB block allowing the DMA to read and write the DMA descriptors and the source and destination data for the DMA transfers
- A DMA control block controlling the operation of the DMA, including request/acknowledge signals for the connected peripherals
- A channel select block routing the right peripheral request to each DMA channel

8.4 Functional Description

The DMA Controller is highly flexible. It is capable of transferring data between peripherals and memory without involvement from the processor core. This can be used to increase system performance by

off-loading the processor from copying large amounts of data or avoiding frequent interrupts to service peripherals needing more data or having available data. It can also be used to reduce the system energy consumption by making the DMA work autonomously with the LEUART for data transfer in EM2 without having to wake up the processor core from sleep.

The DMA Controller contains 8 independent channels. Each of these channels can be connected to any of the available peripheral trigger sources by writing to the configuration registers, see Section 8.4.1 (p. 40) . In addition, each channel can be triggered by software (for large memory transfers or for debugging purposes).

What the DMA Controller should do when one of its channels is triggered, is configured through channel descriptors residing in system memory. Before enabling a channel, the software must therefore take care to write this configuration to memory. When the channel is triggered, the DMA Controller will first read the channel descriptor from system memory, and then it will proceed to perform the memory transfers as specified by the descriptor. The descriptor contains the memory address to read from, the memory address to write to, the number of bytes to be transferred, etc. The channel descriptor is described in detail in Section 8.4.3 (p. 50) .

In addition to the basic transfer mode, the DMA Controller also supports two advanced transfer modes; ping-pong and scatter-gather. Ping-pong transfers are ideally suited for streaming data for high-speed peripheral communication as the DMA will be ready to retrieve the next incoming data bytes immediately while the processor core is still processing the previous ones (and similarly for outgoing communication). Scatter-gather involves executing a series of tasks from memory, and allows sophisticated schemes to be implemented by software.

Using different priority levels for the channels and setting the number of bytes after which the DMA Controller rearbiterates, it is possible to ensure that timing-critical transfers are serviced on time.

8.4.1 Channel Select Configuration

The channel select block allows selecting which peripheral's request lines (dma_req, dma_sreq) to connect to each DMA channel.

This configuration is done by software through the extra registers DMA_CH0_CTRL- DMA_CH7_CTRL, with SOURCESEL and SIGSEL components. SOURCESEL selects which peripheral to listen to. SIGSEL selects which of the peripheral's output signals is selected.

All peripherals are connected to dma_req. When this signal is triggered, the DMA performs a number of transfers as specified by the channel descriptor (2^R). The USARTs are additionally connected to the dma_sreq line. When only dma_sreq is asserted but not dma_req, then the DMA will perform exactly one transfer only (given that dma_sreq is enabled by software).

8.4.2 DMA control

8.4.2.1 DMA arbitration rate

You can configure when the controller arbitrates during a DMA transfer. This enables you to reduce the latency to service a higher priority channel.

The controller provides four bits that configure how many AHB bus transfers occur before it rearbiterates. These bits are known as the R_power bits because the value you enter, R, is raised to the power of two and this determines the arbitration rate. For example, if R = 4 then the arbitration rate is 2^4 , that is, the controller arbitrates every 16 DMA transfers.

Table 8.1 (p. 40) lists the arbitration rates.

Table 8.1. AHB bus transfer arbitration interval

R_power	Arbitrate after x DMA transfers
b0000	x = 1

R_power	Arbitrate after x DMA transfers
b0001	x = 2
b0010	x = 4
b0011	x = 8
b0100	x = 16
b0101	x = 32
b0110	x = 64
b0111	x = 128
b1000	x = 256
b1001	x = 512
b1010 - b1111	x = 1024

Note You must take care not to assign a low-priority channel with a large R_power because this prevents the controller from servicing high-priority requests, until it rearbitrates.

When $N > 2^R$ and is not an integer multiple of 2^R then the controller always performs sequences of 2^R transfers until $N < 2^R$ remain to be transferred. The controller performs the remaining N transfers at the end of the DMA cycle.

You store the value of the R_power bits in the channel control data structure. See Section 8.4.3.3 (p. 53) for more information about the location of the R_power bits in the data structure.

8.4.2.2 Priority

When the controller arbitrates, it determines the next channel to service by using the following information:

- the channel number
- the priority level, default or high, that is assigned to the channel.

You can configure each channel to use either the default priority level or a high priority level by setting the DMA_CHPRIS register.

Channel number zero has the highest priority and as the channel number increases, the priority of a channel decreases. Table 8.2 (p. 41) lists the DMA channel priority levels in descending order of priority.

Table 8.2. DMA channel priority

Channel number	Priority level setting	Descending order of channel priority
0	High	Highest-priority DMA channel
1	High	-
2	High	-
3	High	-
4	High	-
5	High	-
6	High	-
7	High	-
0	Default	-

Channel number	Priority level setting	Descending order of channel priority
1	Default	-
2	Default	-
3	Default	-
4	Default	-
5	Default	-
6	Default	-
7	Default	Lowest-priority DMA channel

After a DMA transfer completes, the controller polls all the DMA channels that are available. Figure 8.2 (p. 42) shows the process it uses to determine which DMA transfer to perform next.

Figure 8.2. Polling flowchart

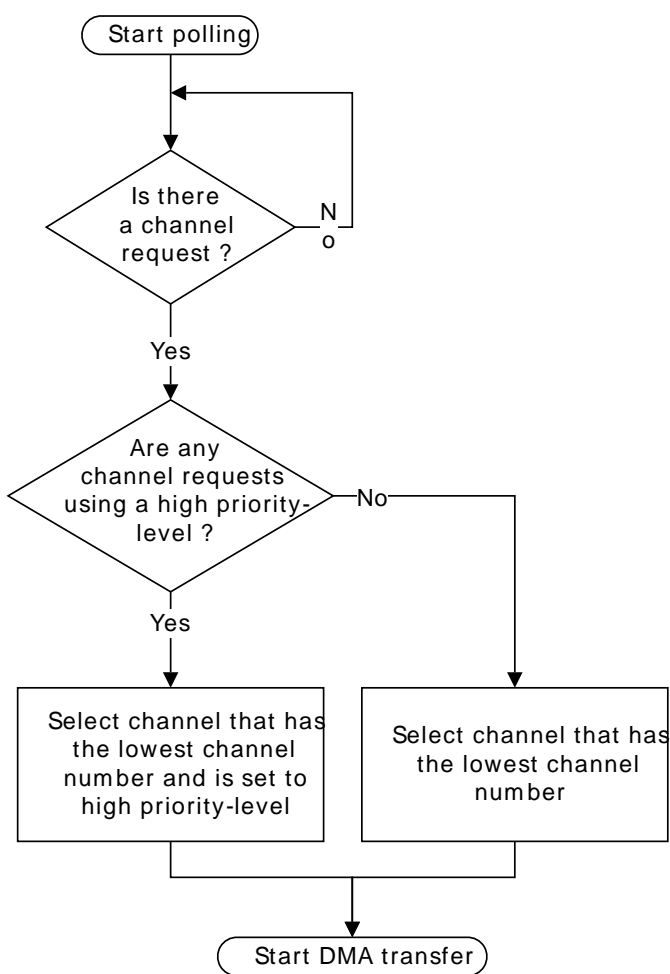

8.4.2.3 DMA cycle types

The cycle_ctrl bits control how the controller performs a DMA cycle. You can set the cycle_ctrl bits as Table 8.3 (p. 42) lists.

Table 8.3. DMA cycle types

cycle_ctrl	Description
b000	Channel control data structure is invalid
b001	Basic DMA transfer

cycle_ctrl	Description
b010	Auto-request
b011	Ping-pong
b100	Memory scatter-gather using the primary data structure
b101	Memory scatter-gather using the alternate data structure
b110	Peripheral scatter-gather using the primary data structure
b111	Peripheral scatter-gather using the alternate data structure

Note

The cycle_ctrl bits are located in the channel_cfg memory location that Section 8.4.3.3 (p. 53) describes.

For all cycle types, the controller arbitrates after 2^R DMA transfers. If you set a low-priority channel with a large 2^R value then it prevents all other channels from performing a DMA transfer, until the low-priority DMA transfer completes. Therefore, you must take care when setting the R_power, that you do not significantly increase the latency for high-priority channels.

8.4.2.3.1 Invalid

After the controller completes a DMA cycle it sets the cycle type to invalid, to prevent it from repeating the same DMA cycle.

8.4.2.3.2 Basic

In this mode, you configure the controller to use either the primary, or alternate, data structure. After you enable the channel, and the controller receives a request then the flow for this DMA cycle is:

1. The controller performs 2^R transfers. If the number of transfers remaining is zero the flow continues at step 3 (p. 43) .
2. The controller arbitrates:
 - if a higher-priority channel is requesting service then the controller services that channel
 - if the peripheral or software signals a request to the controller then it continues at step 1 (p. 43) .
3. The controller sets dma_done[C] HIGH for one HFCORECLK cycle. This indicates to the host processor that the DMA cycle is complete.

8.4.2.3.3 Auto-request

When the controller operates in this mode, it is only necessary for it to receive a single request to enable it to complete the entire DMA cycle. This enables a large data transfer to occur, without significantly increasing the latency for servicing higher priority requests, or requiring multiple requests from the processor or peripheral.

You can configure the controller to use the primary, or alternate, data structure. After you enable the channel, and the controller receives a request for this channel, then the flow for this DMA cycle is:

1. The controller performs 2^R transfers for channel C. If the number of transfers remaining is zero the flow continues at step 3 (p. 43) .
2. The controller arbitrates. When channel C has the highest priority then the DMA cycle continues at step 1 (p. 43) .
3. The controller sets dma_done[C] HIGH for one HFCORECLK cycle. This indicates to the host processor that the DMA cycle is complete.

8.4.2.3.4 Ping-pong

In ping-pong mode, the controller performs a DMA cycle using one of the data structures and it then performs a DMA cycle using the other data structure. The controller continues to switch from primary to

alternate to primary... until it reads a data structure that is invalid, or until the host processor disables the channel.

Figure 8.3 (p. 44) shows an example of a ping-pong DMA transaction.

Figure 8.3. Ping-pong example

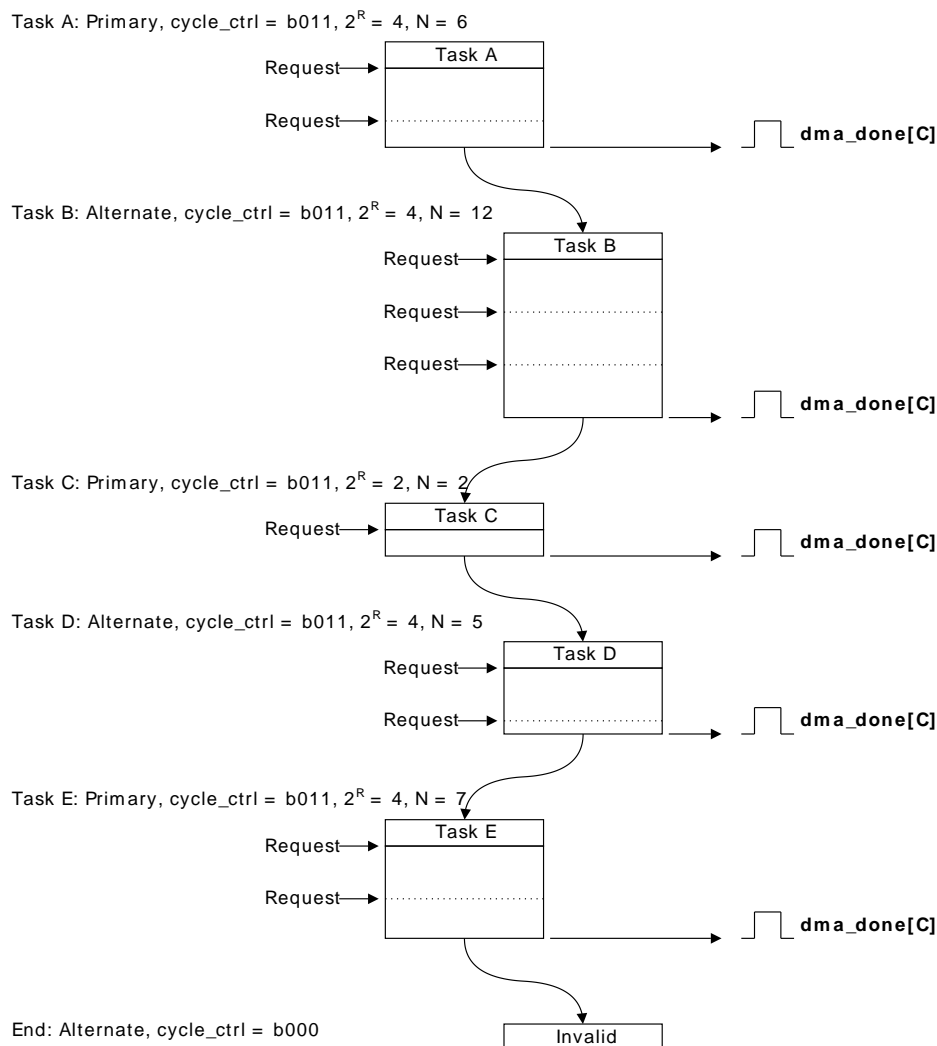

In Figure 8.3 (p. 44) :

- Task A
1. The host processor configures the primary data structure for task A.
 2. The host processor configures the alternate data structure for task B. This enables the controller to immediately switch to task B after task A completes, provided that a higher priority channel does not require servicing.
 3. The controller receives a request and performs four DMA transfers.
 4. The controller arbitrates. After the controller receives a request for this channel, the flow continues if the channel has the highest priority.
 5. The controller performs the remaining two DMA transfers.
 6. The controller sets dma_done[C] HIGH for one HFCORECLK cycle and enters the arbitration process.

After task A completes, the host processor can configure the primary data structure for task C. This enables the controller to immediately switch to task C after task B completes, provided that a higher priority channel does not require servicing.

After the controller receives a new request for the channel and it has the highest priority then task B commences:

- Task B
7. The controller performs four DMA transfers.
 8. The controller arbitrates. After the controller receives a request for this channel, the flow continues if the channel has the highest priority.
 9. The controller performs four DMA transfers.
 10. The controller arbitrates. After the controller receives a request for this channel, the flow continues if the channel has the highest priority.
 11. The controller performs the remaining four DMA transfers.
 12. The controller sets `dma_done[C]` HIGH for one `HFCORECLK` cycle and enters the arbitration process.

After task B completes, the host processor can configure the alternate data structure for task D.

After the controller receives a new request for the channel and it has the highest priority then task C commences:

- Task C
13. The controller performs two DMA transfers.
 14. The controller sets `dma_done[C]` HIGH for one `HFCORECLK` cycle and enters the arbitration process.

After task C completes, the host processor can configure the primary data structure for task E.

After the controller receives a new request for the channel and it has the highest priority then task D commences:

- Task D
15. The controller performs four DMA transfers.
 16. The controller arbitrates. After the controller receives a request for this channel, the flow continues if the channel has the highest priority.
 17. The controller performs the remaining DMA transfer.
 18. The controller sets `dma_done[C]` HIGH for one `HFCORECLK` cycle and enters the arbitration process.

After the controller receives a new request for the channel and it has the highest priority then task E commences:

- Task E
19. The controller performs four DMA transfers.
 20. The controller arbitrates. After the controller receives a request for this channel, the flow continues if the channel has the highest priority.
 21. The controller performs the remaining three DMA transfers.
 22. The controller sets `dma_done[C]` HIGH for one `HFCORECLK` cycle and enters the arbitration process.

If the controller receives a new request for the channel and it has the highest priority then it attempts to start the next task. However, because the host processor has not configured the alternate data structure, and on completion of task D the controller set the `cycle_ctrl` bits to `b000`, then the ping-pong DMA transaction completes.

Note

You can also terminate the ping-pong DMA cycle in Figure 8.3 (p. 44), if you configure task E to be a basic DMA cycle by setting the `cycle_ctrl` field to `3'b001`.

8.4.2.3.5 Memory scatter-gather

In memory scatter-gather mode the controller receives an initial request and then performs four DMA transfers using the primary data structure. After this transfer completes, it starts a DMA cycle using the

alternate data structure. After this cycle completes, the controller performs another four DMA transfers using the primary data structure. The controller continues to switch from primary to alternate to primary... until either:

- the host processor configures the alternate data structure for a basic cycle
- it reads an invalid data structure.

Note

After the controller completes the N primary transfers it invalidates the primary data structure by setting the `cycle_ctrl` field to b000.

The controller only asserts `dma_done[C]` when the scatter-gather transaction completes using an auto-request cycle.

In scatter-gather mode, the controller uses the primary data structure to program the alternate data structure. Table 8.4 (p. 46) lists the fields of the `channel_cfg` memory location for the primary data structure, that you must program with constant values and those that can be user defined.

Table 8.4. `channel_cfg` for a primary data structure, in memory scatter-gather mode

Bit	Field	Value	Description
Constant-value fields:			
[31:30]	<code>dst_inc</code>	b10	Configures the controller to use word increments for the address
[29:28]	<code>dst_size</code>	b10	Configures the controller to use word transfers
[27:26]	<code>src_inc</code>	b10	Configures the controller to use word increments for the address
[25:24]	<code>src_size</code>	b10	Configures the controller to use word transfers
[17:14]	<code>R_power</code>	b0010	Configures the controller to perform four DMA transfers
[3]	<code>next_useburst</code>	0	For a memory scatter-gather DMA cycle, this bit must be set to zero
[2:0]	<code>cycle_ctrl</code>	b100	Configures the controller to perform a memory scatter-gather DMA cycle
User defined values:			
[23:21]	<code>dst_prot_ctrl</code>	-	Configures the state of <code>HPROT</code> when the controller writes the destination data
[20:18]	<code>src_prot_ctrl</code>	-	Configures the state of <code>HPROT</code> when the controller reads the source data
[13:4]	<code>n_minus_1</code>	N^1	Configures the controller to perform N DMA transfers, where N is a multiple of four

¹Because the `R_power` field is set to four, you must set N to be a multiple of four. The value given by $N/4$ is the number of times that you must configure the alternate data structure.

See Section 8.4.3.3 (p. 53) for more information.

Figure 8.4 (p. 47) shows a memory scatter-gather example.

Figure 8.4. Memory scatter-gather example

Initialization: 1. Configure primary to enable the copy A, B, C, and D operations: cycle_ctrl = b100, 2^R = 4, N = 16.
 2. Write the primary source data to memory, using the structure shown in the following table.

	src_data_end_ptr	dst_data_end_ptr	channel_cfg	Unused
Data for Task A	0x0A000000	0x0AE00000	cycle_ctrl = b101, 2 ^R = 4, N = 3	0xFFFFFFFF
Data for Task B	0x0B000000	0x0BE00000	cycle_ctrl = b101, 2 ^R = 2, N = 8	0xFFFFFFFF
Data for Task C	0x0C000000	0x0CE00000	cycle_ctrl = b101, 2 ^R = 8, N = 5	0xFFFFFFFF
Data for Task D	0x0D000000	0x0DE00000	cycle_ctrl = b010, 2 ^R = 4, N = 4	0xFFFFFFFF

Memory scatter-gather transaction:

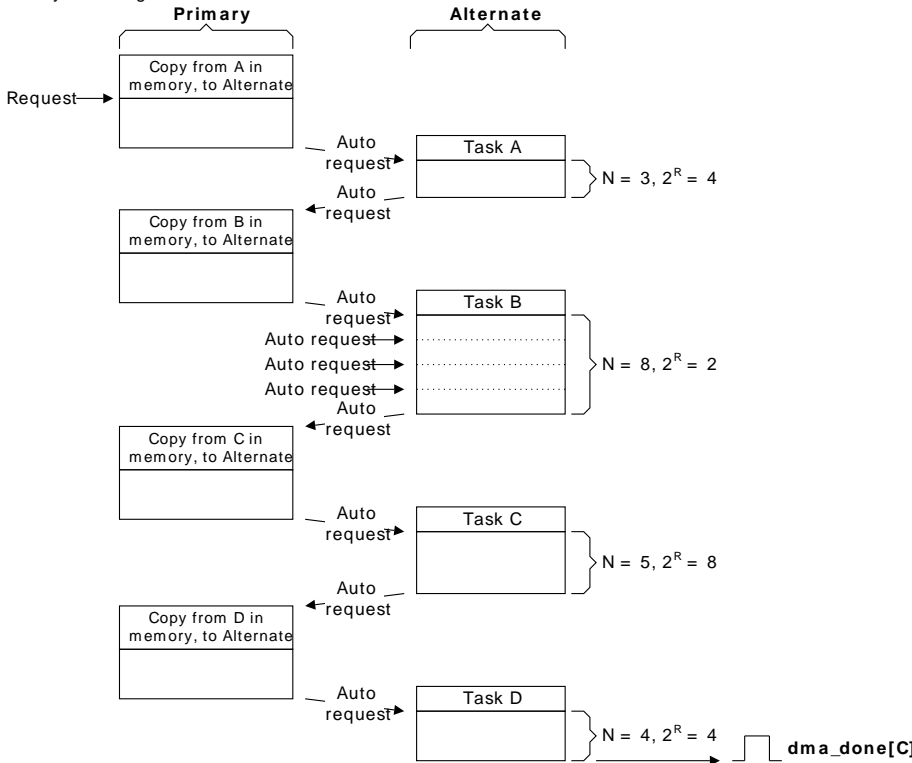

In Figure 8.4 (p. 47) :

Initialization

1. The host processor configures the primary data structure to operate in memory scatter-gather mode by setting cycle_ctrl to b100. Because a data structure for a single channel consists of four words then you must set 2^R to 4. In this example, there are four tasks and therefore N is set to 16.
2. The host processor writes the data structure for tasks A, B, C, and D to the memory locations that the primary src_data_end_ptr specifies.
3. The host processor enables the channel.

The memory scatter-gather transaction commences when the controller receives a request on dma_req[] or a manual request from the host processor. The transaction continues as follows:

Primary, copy A

1. After receiving a request, the controller performs four DMA transfers. These transfers write the alternate data structure for task A.

Task A

2. The controller generates an auto-request for the channel and then arbitrates.
3. The controller performs task A. After it completes the task, it generates an auto-request for the channel and then arbitrates.

Primary, copy B

4. The controller performs four DMA transfers. These transfers write the alternate data structure for task B.

Task B

5. The controller generates an auto-request for the channel and then arbitrates.
6. The controller performs task B. After it completes the task, it generates an auto-request for the channel and then arbitrates.

Primary, copy C

7. The controller performs four DMA transfers. These transfers write the alternate data structure for task C.

- 8. The controller generates an auto-request for the channel and then arbitrates.
- Task C 9. The controller performs task C. After it completes the task, it generates an auto-request for the channel and then arbitrates.
- Primary, copy D 10. The controller performs four DMA transfers. These transfers write the alternate data structure for task D.
- 11. The controller sets the cycle_ctrl bits of the primary data structure to b000, to indicate that this data structure is now invalid.
- 12. The controller generates an auto-request for the channel and then arbitrates.
- Task D 13. The controller performs task D using an auto-request cycle.
- 14. The controller sets dma_done [C] HIGH for one HFCORECLK cycle and enters the arbitration process.

8.4.2.3.6 Peripheral scatter-gather

In peripheral scatter-gather mode the controller receives an initial request from a peripheral and then it performs four DMA transfers using the primary data structure. It then immediately starts a DMA cycle using the alternate data structure, without re-arbitrating.

Note These are the only circumstances, where the controller does not enter the arbitration process after completing a transfer using the primary data structure.

After this cycle completes, the controller re-arbitrates and if the controller receives a request from the peripheral that has the highest priority then it performs another four DMA transfers using the primary data structure. It then immediately starts a DMA cycle using the alternate data structure, without re-arbitrating. The controller continues to switch from primary to alternate to primary... until either:

- the host processor configures the alternate data structure for a basic cycle
- it reads an invalid data structure.

Note After the controller completes the N primary transfers it invalidates the primary data structure by setting the cycle_ctrl field to b000.

The controller asserts dma_done [C] when the scatter-gather transaction completes using a basic cycle.

In scatter-gather mode, the controller uses the primary data structure to program the alternate data structure. Table 8.5 (p. 48) lists the fields of the channel_cfg memory location for the primary data structure, that you must program with constant values and those that can be user defined.

Table 8.5. channel_cfg for a primary data structure, in peripheral scatter-gather mode

Bit	Field	Value	Description
Constant-value fields:			
[31:30]	dst_inc	b10	Configures the controller to use word increments for the address
[29:28]	dst_size	b10	Configures the controller to use word transfers
[27:26]	src_inc	b10	Configures the controller to use word increments for the address
[25:24]	src_size	b10	Configures the controller to use word transfers
[17:14]	R_power	b0010	Configures the controller to perform four DMA transfers
[2:0]	cycle_ctrl	b110	Configures the controller to perform a peripheral scatter-gather DMA cycle
User defined values:			
[23:21]	dst_prot_ctrl	-	Configures the state of HPROT when the controller writes the destination data
[20:18]	src_prot_ctrl	-	Configures the state of HPROT when the controller reads the source data

Bit	Field	Value	Description
[13:4]	n_minus_1	N ¹	Configures the controller to perform N DMA transfers, where N is a multiple of four
[3]	next_useburst	-	When set to 1, the controller sets the chnl_useburst_set [C] bit to 1 after the alternate transfer completes

¹Because the R_power field is set to four, you must set N to be a multiple of four. The value given by N/4 is the number of times that you must configure the alternate data structure.

See Section 8.4.3.3 (p. 53) for more information.

Figure 8.5 (p. 49) shows a peripheral scatter-gather example.

Figure 8.5. Peripheral scatter-gather example

Initialization: 1. Configure primary to enable the copy A, B, C, and D operations: cycle_ctrl = b110, 2^R = 4, N = 16.
 2. Write the primary source data in memory, using the structure shown in the following table.

	src_data_end_ptr	dst_data_end_ptr	channel_cfg	Unused
Data for Task A	0x0A000000	0x0AE00000	cycle_ctrl = b111, 2 ^R = 4, N = 3	0xFFFFFFFF
Data for Task B	0x0B000000	0x0BE00000	cycle_ctrl = b111, 2 ^R = 2, N = 8	0xFFFFFFFF
Data for Task C	0x0C000000	0x0CE00000	cycle_ctrl = b111, 2 ^R = 8, N = 5	0xFFFFFFFF
Data for Task D	0x0D000000	0x0DE00000	cycle_ctrl = b001, 2 ^R = 4, N = 4	0xFFFFFFFF

Peripheral scatter-gather transaction:

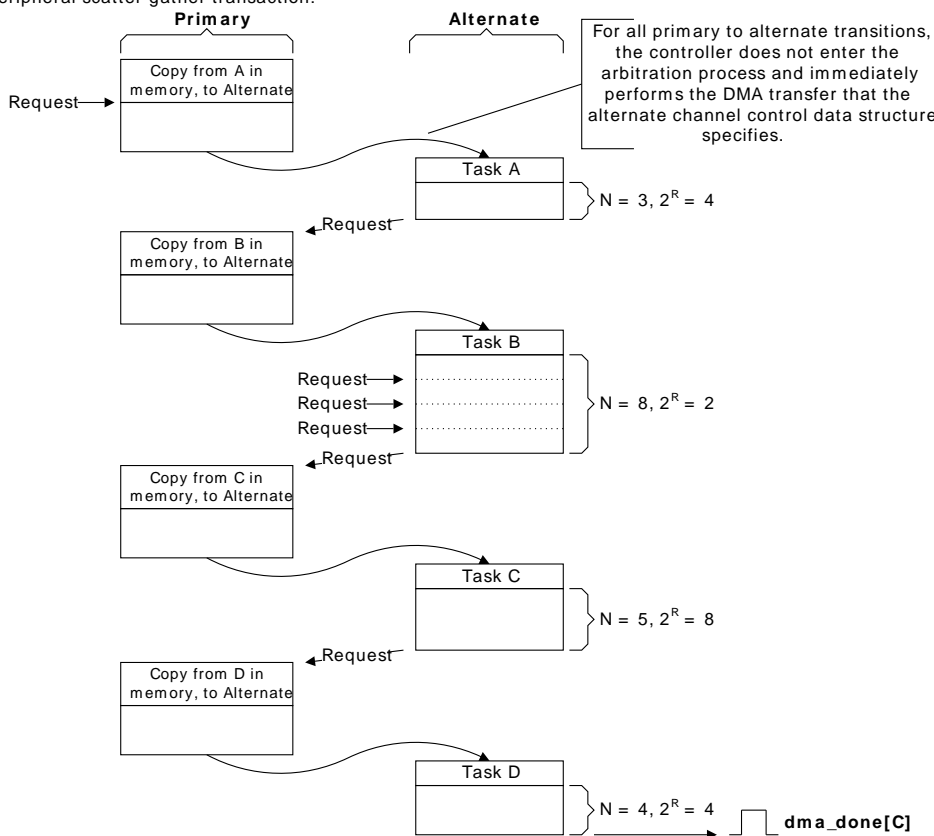

In Figure 8.5 (p. 49) :

Initialization

1. The host processor configures the primary data structure to operate in peripheral scatter-gather mode by setting cycle_ctrl to b110. Because a data structure for a single channel consists of four words then you must set 2^R to 4. In this example, there are four tasks and therefore N is set to 16.
2. The host processor writes the data structure for tasks A, B, C, and D to the memory locations that the primary src_data_end_ptr specifies.
3. The host processor enables the channel.

The peripheral scatter-gather transaction commences when the controller receives a request on dma_req[]. The transaction continues as follows:

- Primary, copy A 1. After receiving a request, the controller performs four DMA transfers. These transfers write the alternate data structure for task A.
- Task A 2. The controller performs task A.
3. After the controller completes the task it enters the arbitration process.

After the peripheral issues a new request and it has the highest priority then the process continues with:

- Primary, copy B 4. The controller performs four DMA transfers. These transfers write the alternate data structure for task B.
- Task B 5. The controller performs task B. To enable the controller to complete the task, the peripheral must issue a further three requests.
6. After the controller completes the task it enters the arbitration process.

After the peripheral issues a new request and it has the highest priority then the process continues with:

- Primary, copy C 7. The controller performs four DMA transfers. These transfers write the alternate data structure for task C.
- Task C 8. The controller performs task C.
9. After the controller completes the task it enters the arbitration process.

After the peripheral issues a new request and it has the highest priority then the process continues with:

- Primary, copy D 10. The controller performs four DMA transfers. These transfers write the alternate data structure for task D.
11. The controller sets the cycle_ctrl bits of the primary data structure to b000, to indicate that this data structure is now invalid.
- Task D 12. The controller performs task D using a basic cycle.
13. The controller sets dma_done[C] HIGH for one HFCORECLK cycle and enters the arbitration process.

8.4.2.4 Error signaling

If the controller detects an ERROR response on the AHB-Lite master interface, it:

- disables the channel that corresponds to the ERROR
- sets dma_err HIGH.

After the host processor detects that dma_err is HIGH, it must check which channel was active when the ERROR occurred. It can do this by:

1. Reading the DMA_CHENS register to create a list of disabled channels.

When a channel asserts dma_done[] then the controller disables the channel. The program running on the host processor must always keep a record of which channels have recently asserted their dma_done[] outputs.

2. It must compare the disabled channels list from step 1 (p. 50), with the record of the channels that have recently set their dma_done[] outputs. The channel with no record of dma_done[C] being set is the channel that the ERROR occurred on.

8.4.3 Channel control data structure

You must provide an area of system memory to contain the channel control data structure. This system memory must:

- provide a contiguous area of system memory that the controller and host processor can access
- have a base address that is an integer multiple of the total size of the channel control data structure.

Figure 8.6 (p. 51) shows the memory that the controller requires for the channel control data structure, when all 8 channels and the optional alternate data structure are in use.

Figure 8.6. Memory map for 8 channels, including the alternate data structure

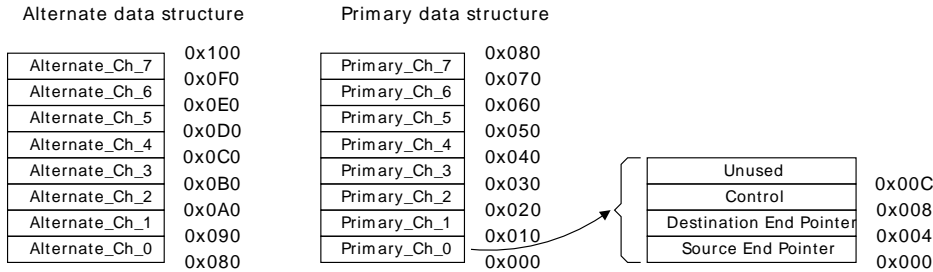

This structure in Figure 8.6 (p. 51) uses 256 bytes of system memory. The controller uses the lower 8 address bits to enable it to access all of the elements in the structure and therefore the base address must be at 0xXXXXXX00.

You can configure the base address for the primary data structure by writing the appropriate value in the DMA_CTRLBASE register.

You do not need to set aside the full 256 bytes if not all 8 channels are used or not all alternate descriptors are used. If e.g. only 4 channels are used and they only need the primary descriptors, then only 64 bytes need be set aside.

Table 8.6 (p. 51) lists the address bits that the controller uses when it accesses the elements of the channel control data structure.

Table 8.6. Address bit settings for the channel control data structure

Address bits				
[7]	[6]	[5]	[4]	[3:0]
A	C[2]	C[1]	C[0]	0x0, 0x4, or 0x8

Where:

- A** Selects one of the channel control data structures:
 A = 0 Selects the primary data structure.
 A = 1 Selects the alternate data structure.
- C[2:0]** Selects the DMA channel.
- Address[3:0]** Selects one of the control elements:
 0x0 Selects the source data end pointer.
 0x4 Selects the destination data end pointer.
 0x8 Selects the control data configuration.
 0xC The controller does not access this address location. If required, you can enable the host processor to use this memory location as system memory.

Note

It is not necessary for you to calculate the base address of the alternate data structure because the DMA_ALTCTRLBASE register provides this information.

Figure 8.7 (p. 52) shows a detailed memory map of the descriptor structure.

Figure 8.7. Detailed memory map for the 8 channels, including the alternate data structure

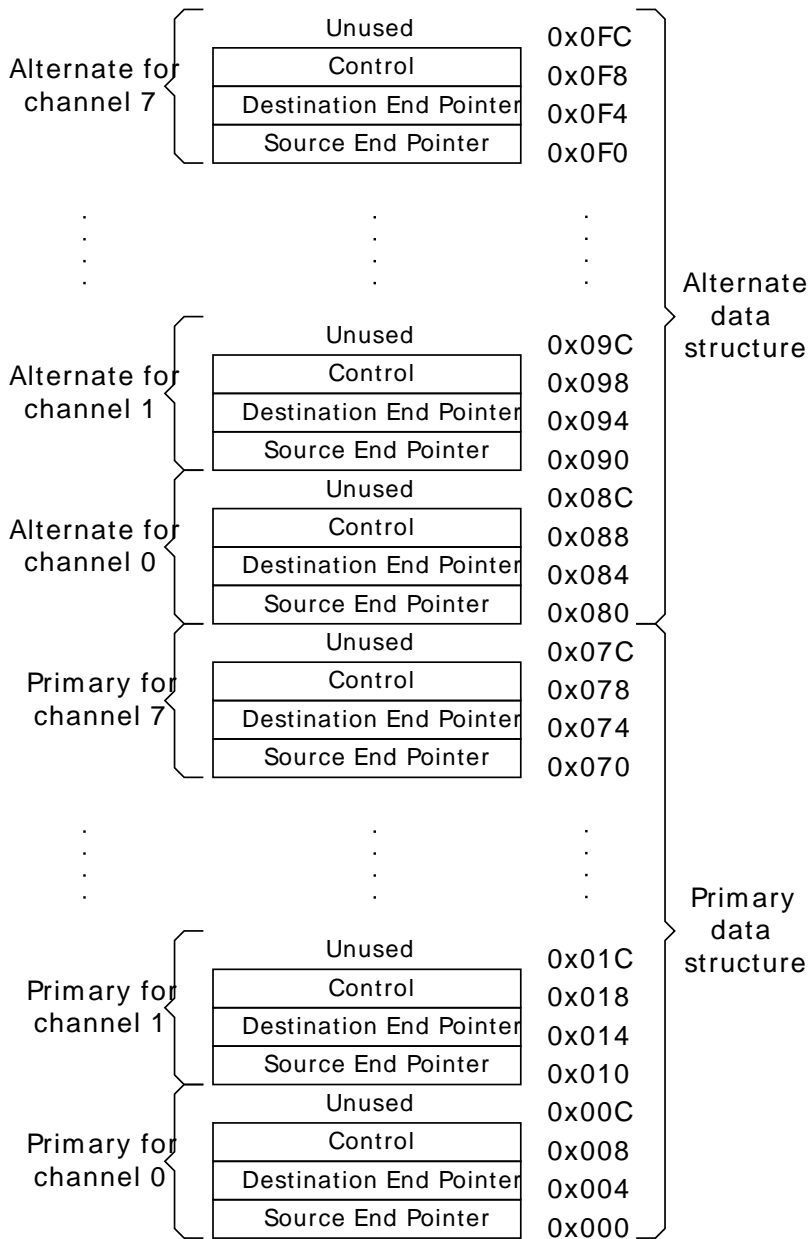

The controller uses the system memory to enable it to access two pointers and the control information that it requires for each channel. The following subsections will describe these 32-bit memory locations and how the controller calculates the DMA transfer address.

8.4.3.1 Source data end pointer

The `src_data_end_ptr` memory location contains a pointer to the end address of the source data. Figure 8.7 (p. 52) lists the bit assignments for this memory location.

Table 8.7. `src_data_end_ptr` bit assignments

Bit	Name	Description
[31:0]	<code>src_data_end_ptr</code>	Pointer to the end address of the source data

Before the controller can perform a DMA transfer, you must program this memory location with the end address of the source data. The controller reads this memory location when it starts a 2^R DMA transfer.

Note

The controller does not write to this memory location.

Bit	Name	Description
[13:4]	n_minus_1	<p>Prior to the DMA cycle commencing, these bits represent the total number of DMA transfers that the DMA cycle contains. You must set these bits according to the size of DMA cycle that you require.</p> <p>The 10-bit value indicates the number of DMA transfers, minus one. The possible values are:</p> <p>b000000000 = 1 DMA transfer</p> <p>b000000001 = 2 DMA transfers</p> <p>b000000010 = 3 DMA transfers</p> <p>b000000011 = 4 DMA transfers</p> <p>b000000100 = 5 DMA transfers</p> <p>.</p> <p>.</p> <p>.</p> <p>b111111111 = 1024 DMA transfers.</p> <p>The controller updates this field immediately prior to it entering the arbitration process. This enables the controller to store the number of outstanding DMA transfers that are necessary to complete the DMA cycle.</p>
[3]	next_useburst	<p>Controls if the chnl_useburst_set [C] bit is set to a 1, when the controller is performing a peripheral scatter-gather and is completing a DMA cycle that uses the alternate data structure.</p> <div style="background-color: #f0f0f0; padding: 5px; margin: 10px 0;"> <p>Note</p> <p>Immediately prior to completion of the DMA cycle that the alternate data structure specifies, the controller sets the chnl_useburst_set [C] bit to 0 if the number of remaining transfers is less than 2^R. The setting of the next_useburst bit controls if the controller performs an additional modification of the chnl_useburst_set [C] bit.</p> </div> <p>In peripheral scatter-gather DMA cycle then after the DMA cycle that uses the alternate data structure completes, either:</p> <p>0 = the controller does not change the value of the chnl_useburst_set [C] bit. If the chnl_useburst_set [C] bit is 0 then for all the remaining DMA cycles in the peripheral scatter-gather transaction, the controller responds to requests on dma_req[] and dma_sreq[], when it performs a DMA cycle that uses an alternate data structure.</p> <p>1 = the controller sets the chnl_useburst_set [C] bit to a 1. Therefore, for the remaining DMA cycles in the peripheral scatter-gather transaction, the controller only responds to requests on dma_req[], when it performs a DMA cycle that uses an alternate data structure.</p>
[2:0]	cycle_ctrl	<p>The operating mode of the DMA cycle. The modes are:</p> <p>b000 Stop. Indicates that the data structure is invalid.</p> <p>b001 Basic. The controller must receive a new request, prior to it entering the arbitration process, to enable the DMA cycle to complete.</p> <p>b010 Auto-request. The controller automatically inserts a request for the appropriate channel during the arbitration process. This means that the initial request is sufficient to enable the DMA cycle to complete.</p> <p>b011 Ping-pong. The controller performs a DMA cycle using one of the data structures. After the DMA cycle completes, it performs a DMA cycle using the other data structure. After the DMA cycle completes and provided that the host processor has updated the original data structure, it performs a DMA cycle using the original data structure. The controller continues to perform DMA cycles until it either reads an invalid data structure or the host processor changes the cycle_ctrl bits to b001 or b010. See Section 8.4.2.3.4 (p. 43).</p> <p>b100 Memory scatter/gather. See Section 8.4.2.3.5 (p. 45).</p> <p>When the controller operates in memory scatter-gather mode, you must only use this value in the primary data structure.</p> <p>b101 Memory scatter/gather. See Section 8.4.2.3.5 (p. 45).</p> <p>When the controller operates in memory scatter-gather mode, you must only use this value in the alternate data structure.</p> <p>b110 Peripheral scatter/gather. See Section 8.4.2.3.6 (p. 48).</p> <p>When the controller operates in peripheral scatter-gather mode, you must only use this value in the primary data structure.</p> <p>b111 Peripheral scatter/gather. See Section 8.4.2.3.6 (p. 48).</p>

Bit	Name	Description
		When the controller operates in peripheral scatter-gather mode, you must only use this value in the alternate data structure.

At the start of a DMA cycle, or 2^R DMA transfer, the controller fetches the channel_cfg from system memory. After it performs 2^R, or N, transfers it stores the updated channel_cfg in system memory.

The controller does not support a dst_size value that is different to the src_size value. If it detects a mismatch in these values, it uses the src_size value for source and destination and when it next updates the n_minus_1 field, it also sets the dst_size field to the same as the src_size field.

After the controller completes the N transfers it sets the cycle_ctrl field to b000, to indicate that the channel_cfg data is invalid. This prevents it from repeating the same DMA transfer.

8.4.3.4 Address calculation

To calculate the source address of a DMA transfer, the controller performs a left shift operation on the n_minus_1 value by a shift amount that src_inc specifies, and then subtracts the resulting value from the source data end pointer. Similarly, to calculate the destination address of a DMA transfer, it performs a left shift operation on the n_minus_1 value by a shift amount that dst_inc specifies, and then subtracts the resulting value from the destination end pointer.

Depending on the value of src_inc and dst_inc, the source address and destination address can be calculated using the equations:

- src_inc = b00 and dst_inc = b00
 - source address = src_data_end_ptr - n_minus_1
 - destination address = dst_data_end_ptr - n_minus_1.
- src_inc = b01 and dst_inc = b01
 - source address = src_data_end_ptr - (n_minus_1 << 1)
 - destination address = dst_data_end_ptr - (n_minus_1 << 1).
- src_inc = b10 and dst_inc = b10
 - source address = src_data_end_ptr - (n_minus_1 << 2)
 - destination address = dst_data_end_ptr - (n_minus_1 << 2).
- src_inc = b11 and dst_inc = b11
 - source address = src_data_end_ptr
 - destination address = dst_data_end_ptr.

Table 8.10 (p. 56) lists the destination addresses for a DMA cycle of six words.

Table 8.10. DMA cycle of six words using a word increment

Initial values of channel_cfg, prior to the DMA cycle				
src_size = b10, dst_inc = b10, n_minus_1 = b101, cycle_ctrl = 1				
	End Pointer	Count	Difference ¹	Address
DMA transfers	0x2AC	5	0x14	0x298
	0x2AC	4	0x10	0x29C
	0x2AC	3	0xC	0x2A0
	0x2AC	2	0x8	0x2A4
	0x2AC	1	0x4	0x2A8
	0x2AC	0	0x0	0x2AC
Final values of channel_cfg, after the DMA cycle				
src_size = b10, dst_inc = b10, n_minus_1 = 0, cycle_ctrl = 0				

¹This value is the result of count being shifted left by the value of dst_inc.

Table 8.11 (p. 57) lists the destination addresses for a DMA transfer of 12 bytes using a halfword increment.

Table 8.11. DMA cycle of 12 bytes using a halfword increment

Initial values of channel_cfg, prior to the DMA cycle				
src_size = b00, dst_inc = b01, n_minus_1 = b1011, cycle_ctrl = 1, R_power = b11				
	End Pointer	Count	Difference ¹	Address
DMA transfers	0x5E7	11	0x16	0x5D1
	0x5E7	10	0x14	0x5D3
	0x5E7	9	0x12	0x5D5
	0x5E7	8	0x10	0x5D7
	0x5E7	7	0xE	0x5D9
	0x5E7	6	0xC	0x5DB
	0x5E7	5	0xA	0x5DD
	0x5E7	4	0x8	0x5DF
Values of channel_cfg after 2 ^R DMA transfers				
src_size = b00, dst_inc = b01, n_minus_1 = b011, cycle_ctrl = 1, R_power = b11				
	End Pointer	Count	Difference	Address
DMA transfers	0x5E7	3	0x6	0x5E1
	0x5E7	2	0x4	0x5E3
	0x5E7	1	0x2	0x5E5
	0x5E7	0	0x0	0x5E7
Final values of channel_cfg, after the DMA cycle				
src_size = b00, dst_inc = b01, n_minus_1 = 0, cycle_ctrl = 0 ² , R_power = b11				

¹This value is the result of count being shifted left by the value of dst_inc.

²After the controller completes the DMA cycle it invalidates the channel_cfg memory location by clearing the cycle_ctrl field.

8.4.4 Interaction with the EMU

The DMA interacts with the Energy Management Unit (EMU) to allow transfers from e.g. the LEUART to occur in EM2. The EMU can wake up the DMA sufficiently long to allow data transfers to occur. See section "DMA Support" in the LEUART documentation.

8.4.5 Interrupts

The PL230 dma_done[n:0] signals, one for each channel, as well as the dma_err signal, are available as interrupts to the Cortex-M3 core. They are combined into one interrupt vector, DMA_INT. If interrupts for the DMA is enabled in the ARM Cortex-M3 core, an interrupt will be made if one or more of the interrupt flags in DMA_IF and their corresponding bits in DMA_IEN are set.

8.5 Examples

A basic example of how to program the DMA for transferring 42 bytes from the USART1 to memory location 0x20003420. Assumes that the channel 0 is currently disabled, and that the DMA_ALTCTRLBASE register has already been configured.

Example 8.1. DMA Transfer

1. Configure the channel select for using USART1 with DMA channel 0
 - a. Write SOURCESEL=0b001101 and SIGSEL=XX to DMA_CHCTRL0
2. Configure the primary channel descriptor for DMA channel 0
 - a. Write XX (read address of USART1) to src_data_end_ptr
 - b. Write 0x20003420 + 40 to dst_data_end_ptr
 - c. Write these values to channel_cfg for channel 0:
 - i. dst_inc=b01 (destination halfword address increment)
 - ii. dst_size=b01 (halfword transfer size)
 - iii. src_inc=b11 (no address increment for source)
 - iv. src_size=01 (halfword transfer size)
 - v. dst_prot_ctrl=000 (no cache/buffer/privilege)
 - vi. src_prot_ctrl=000 (no cache/buffer/privilege)
 - vii. R_power=b0000 (arbitrate after each DMA transfer)
 - viii. in_minus_1=d20 (transfer 21 halfwords)
 - ix. next_useburst=b0 (not applicable)
 - x. cycle_ctrl=b001 (basic operating mode)
3. Enable the DMA
 - a. Write EN=1 to DMA_CONFIG
4. Disable the single requests for channel 0 (i.e. do not react to data available, wait for buffer full)
 - a. Write DMA_CHUSEBURSTS[0]=1
5. Enable buffer-full requests for channel 0
 - a. Write DMA_CHREQMASKC[0]=1
6. Use the primary data structure for channel 0
 - a. Write DMA_CHALTC[0]=1
7. Enable channel 0
 - a. Write DMA_CHENS[0]=1

8.6 Register Map

The offset register address is relative to the registers base address.

Offset	Name	Type	Description
0x000	DMA_STATUS	R	DMA Status Registers
0x004	DMA_CONFIG	W	DMA Configuration Register
0x008	DMA_CTRLBASE	RW	Channel Control Data Base Pointer Register
0x00C	DMA_ALTCTRLBASE	R	Channel Alternate Control Data Base Pointer Register
0x010	DMA_CHWAITSTATUS	R	Channel Wait on Request Status Register
0x014	DMA_CHSWREQ	W1	Channel Software Request Register
0x018	DMA_CHUSEBURSTS	RW1	Channel Useburst Set Register
0x01C	DMA_CHUSEBURSTC	W1	Channel Useburst Clear Register
0x020	DMA_CHREQMASKS	RW1	Channel Request Mask Set Register
0x024	DMA_CHREQMASKC	W1	Channel Request Mask Clear Register
0x028	DMA_CHENS	RW1	Channel Enable Set Register
0x02C	DMA_CHENC	W1	Channel Enable Clear Register
0x030	DMA_CHALTS	RW1	Channel Alternate Set Register
0x034	DMA_CHALTC	W1	Channel Alternate Clear Register
0x038	DMA_CHPRIS	RW1	Channel Priority Set Register
0x03C	DMA_CHPRIC	W1	Channel Priority Clear Register
0x04C	DMA_ERRORC	RW	Bus Error Clear Register
0xE10	DMA_CHREQSTATUS	R	Channel Request Status
0xE18	DMA_CHSREQSTATUS	R	Channel Single Request Status
0x1000	DMA_IF	R	Interrupt Flag Register
0x1004	DMA_IFS	W1	Interrupt Flag Set Register
0x1008	DMA_IFC	W1	Interrupt Flag Clear Register
0x100C	DMA_IEN	RW	Interrupt Enable register
0x1100	DMA_CH0_CTRL	RW	Channel Control Register
0x1104	DMA_CH1_CTRL	RW	Channel Control Register
0x1108	DMA_CH2_CTRL	RW	Channel Control Register
0x110C	DMA_CH3_CTRL	RW	Channel Control Register
0x1110	DMA_CH4_CTRL	RW	Channel Control Register
0x1114	DMA_CH5_CTRL	RW	Channel Control Register
0x1118	DMA_CH6_CTRL	RW	Channel Control Register
0x111C	DMA_CH7_CTRL	RW	Channel Control Register

8.7 Register Description

8.7.1 DMA_STATUS - DMA Status Registers

Offset	Bit Position																																
0x000	31	30	29	28	27	26	25	24	23	22	21	20	19	18	17	16	15	14	13	12	11	10	9	8	7	6	5	4	3	2	1	0	
Reset													0x07																0x0				0
Access													R																R				R
Name													CHNUM																STATE				EN

Bit	Name	Reset	Access	Description
31:21	Reserved	To ensure compatibility with future devices, always write bits to 0. More information in Section 2.1 (p. 3)		
20:16	CHNUM	0x07	R	Channel Number Number of available DMA channels minus one. Always reads as 7, as there are 8 channels.
15:8	Reserved	To ensure compatibility with future devices, always write bits to 0. More information in Section 2.1 (p. 3)		
7:4	STATE	0x0	R	Control Current State State can be one of the following. Higher values (11-15) are undefined.
	Value	Mode	Description	
	0	IDLE	Idle	
	1	RDCHCTRLDATA	Reading channel controller data	
	2	RDSRCENDPTR	Reading source data end pointer	
	3	RDDSTENDPTR	Reading destination data end pointer	
	4	RDSRCDATA	Reading source data	
	5	WRDSTDATA	Writing destination data	
	6	WAITREQCLR	Waiting for DMA request to clear	
	7	WRCHCTRLDATA	Writing channel controller data	
	8	STALLED	Stalled	
	9	DONE	Done	
	10	PERSCATTRANS	Peripheral scatter-gather transition	
3:1	Reserved	To ensure compatibility with future devices, always write bits to 0. More information in Section 2.1 (p. 3)		
0	EN	0	R	DMA Enable Status When this bit is 1, the DMA is enabled.

8.7.2 DMA_CONFIG - DMA Configuration Register

Offset	Bit Position																																
0x004	31	30	29	28	27	26	25	24	23	22	21	20	19	18	17	16	15	14	13	12	11	10	9	8	7	6	5	4	3	2	1	0	
Reset																									0								0
Access																									W								W
Name																									CHPROT								EN

Bit	Name	Reset	Access	Description
31:6	Reserved	To ensure compatibility with future devices, always write bits to 0. More information in Section 2.1 (p. 3)		
5	CHPROT	0	W	Channel Protection Control

Bit	Name	Reset	Access	Description
				Control whether accesses done by the DMA controller are privileged or not. When CHPROT = 1 then HPROT is HIGH and the access is privileged. When CHPROT = 0 then HPROT is LOW and the access is non-privileged.
4:1	Reserved	To ensure compatibility with future devices, always write bits to 0. More information in Section 2.1 (p. 3)		
0	EN	0	W	Enable DMA Set this bit to enable the DMA controller.

8.7.3 DMA_CTRLBASE - Channel Control Data Base Pointer Register

Offset	Bit Position																																
0x008	31	30	29	28	27	26	25	24	23	22	21	20	19	18	17	16	15	14	13	12	11	10	9	8	7	6	5	4	3	2	1	0	
Reset																	0x00000000																
Access																	RW																
Name																	CTRLBASE																

Bit	Name	Reset	Access	Description
31:0	CTRLBASE	0x00000000	RW	Channel Control Data Base Pointer The base pointer for a location in system memory that holds the channel control data structure. This register must be written to point to a location in system memory with the channel control data structure before the DMA can be used. Note that ctrl_base_ptr[7:0] must be 0.

8.7.4 DMA_ALTCTRLBASE - Channel Alternate Control Data Base Pointer Register

Offset	Bit Position																																
0x00C	31	30	29	28	27	26	25	24	23	22	21	20	19	18	17	16	15	14	13	12	11	10	9	8	7	6	5	4	3	2	1	0	
Reset																	0x00000080																
Access																	R																
Name																	ALTCTRLBASE																

Bit	Name	Reset	Access	Description
31:0	ALTCTRLBASE	0x00000080	R	Channel Alternate Control Data Base Pointer The base address of the alternate data structure. This register will read as DMA_CTRLBASE + 0x80.

8.7.5 DMA_CHWAITSTATUS - Channel Wait on Request Status Register

Offset	Bit Position																																																						
	31	30	29	28	27	26	25	24	23	22	21	20	19	18	17	16	15	14	13	12	11	10	9	8	7	6	5	4	3	2	1	0																							
0x010																																																							
Reset																									1	1	1	1	1	1	1	1	1	1	1	1	1	1	1	1	1	1	1	1	1	1	1	1	1	1	1	1	1	1	
Access																									R	R	R	R	R	R	R	R	R	R	R	R	R	R	R	R	R	R	R	R	R	R	R	R	R	R	R	R	R	R	R
Name																									CH7WAITSTATUS	CH6WAITSTATUS	CH5WAITSTATUS	CH4WAITSTATUS	CH3WAITSTATUS	CH2WAITSTATUS	CH1WAITSTATUS	CH0WAITSTATUS																							

Bit	Name	Reset	Access	Description
31:8	Reserved	To ensure compatibility with future devices, always write bits to 0. More information in Section 2.1 (p. 3)		
7	CH7WAITSTATUS	1	R	Channel 7 Wait on Request Status Status for wait on request for channel 7.
6	CH6WAITSTATUS	1	R	Channel 6 Wait on Request Status Status for wait on request for channel 6.
5	CH5WAITSTATUS	1	R	Channel 5 Wait on Request Status Status for wait on request for channel 5.
4	CH4WAITSTATUS	1	R	Channel 4 Wait on Request Status Status for wait on request for channel 4.
3	CH3WAITSTATUS	1	R	Channel 3 Wait on Request Status Status for wait on request for channel 3.
2	CH2WAITSTATUS	1	R	Channel 2 Wait on Request Status Status for wait on request for channel 2.
1	CH1WAITSTATUS	1	R	Channel 1 Wait on Request Status Status for wait on request for channel 1.
0	CH0WAITSTATUS	1	R	Channel 0 Wait on Request Status Status for wait on request for channel 0.

8.7.6 DMA_CHSWREQ - Channel Software Request Register

Offset	Bit Position																																																					
	31	30	29	28	27	26	25	24	23	22	21	20	19	18	17	16	15	14	13	12	11	10	9	8	7	6	5	4	3	2	1	0																						
0x014																																																						
Reset																									0	0	0	0	0	0	0	0	0	0	0	0	0	0	0	0	0	0	0	0	0	0	0	0	0	0	0	0	0	0
Access																									W1	W1	W1	W1	W1	W1	W1	W1	W1	W1	W1	W1	W1	W1	W1	W1	W1	W1	W1	W1	W1	W1	W1	W1	W1	W1	W1	W1	W1	W1
Name																									CH7SWREQ	CH6SWREQ	CH5SWREQ	CH4SWREQ	CH3SWREQ	CH2SWREQ	CH1SWREQ	CH0SWREQ																						

Bit	Name	Reset	Access	Description
31:8	Reserved	To ensure compatibility with future devices, always write bits to 0. More information in Section 2.1 (p. 3)		
7	CH7SWREQ	0	W1	Channel 7 Software Request Write 1 to this bit to generate a DMA request for this channel.
6	CH6SWREQ	0	W1	Channel 6 Software Request Write 1 to this bit to generate a DMA request for this channel.

Bit	Name	Reset	Access	Description
5	CH5SWREQ	0	W1	Channel 5 Software Request Write 1 to this bit to generate a DMA request for this channel.
4	CH4SWREQ	0	W1	Channel 4 Software Request Write 1 to this bit to generate a DMA request for this channel.
3	CH3SWREQ	0	W1	Channel 3 Software Request Write 1 to this bit to generate a DMA request for this channel.
2	CH2SWREQ	0	W1	Channel 2 Software Request Write 1 to this bit to generate a DMA request for this channel.
1	CH1SWREQ	0	W1	Channel 1 Software Request Write 1 to this bit to generate a DMA request for this channel.
0	CH0SWREQ	0	W1	Channel 0 Software Request Write 1 to this bit to generate a DMA request for this channel.

8.7.7 DMA_CHUSEBURSTS - Channel Useburst Set Register

Offset	Bit Position																																	
0x018	31	30	29	28	27	26	25	24	23	22	21	20	19	18	17	16	15	14	13	12	11	10	9	8	7	6	5	4	3	2	1	0		
Reset																	0	0	0	0	0	0	0	0	0	0	0	0	0	0	0	0	0	
Access																	RW1	RW1	RW1	RW1	RW1	RW1	RW1	RW1	RW1	RW1	RW1	RW1	RW1	RW1	RW1	RW1	RW1	
Name																	CH7USEBURSTS	CH6USEBURSTS	CH5USEBURSTS	CH4USEBURSTS	CH3USEBURSTS	CH2USEBURSTS	CH1USEBURSTS	CH0USEBURSTS										

Bit	Name	Reset	Access	Description
31:8	<i>Reserved</i>	<i>To ensure compatibility with future devices, always write bits to 0. More information in Section 2.1 (p. 3)</i>		
7	CH7USEBURSTS	0	RW1	Channel 7 Useburst Set See description for channel 0.
6	CH6USEBURSTS	0	RW1	Channel 6 Useburst Set See description for channel 0.
5	CH5USEBURSTS	0	RW1	Channel 5 Useburst Set See description for channel 0.
4	CH4USEBURSTS	0	RW1	Channel 4 Useburst Set See description for channel 0.
3	CH3USEBURSTS	0	RW1	Channel 3 Useburst Set See description for channel 0.
2	CH2USEBURSTS	0	RW1	Channel 2 Useburst Set See description for channel 0.
1	CH1USEBURSTS	0	RW1	Channel 1 Useburst Set See description for channel 0.
0	CH0USEBURSTS	0	RW1	Channel 0 Useburst Set

Write to 1 to enable the useburst setting for this channel. Reading returns the useburst status. After the penultimate 2^NR transfer completes, if the number of remaining transfers, N, is less than 2^NR then the controller resets the chnl_useburst_set bit to 0. This enables you to complete the remaining transfers using dma_req[] or dma_sreq[]. In peripheral scatter-gather mode, if the next_useburst bit is set in channel_cfg then the controller sets the chnl_useburst_set[C] bit to a 1, when it completes the DMA cycle that uses the alternate data structure.

Bit	Name	Reset	Access	Description
	Value	Mode		Description
	0	SINGLEANDBURST		Channel responds to both single and burst requests
	1	BURSTONLY		Channel responds to burst requests only

8.7.8 DMA_CHUSEBURSTC - Channel Useburst Clear Register

Offset	Bit Position																																																					
0x01C	31	30	29	28	27	26	25	24	23	22	21	20	19	18	17	16	15	14	13	12	11	10	9	8	7	6	5	4	3	2	1	0																						
Reset																									0	0	0	0	0	0	0	0	0	0	0	0	0	0	0	0	0	0	0	0	0	0	0	0	0	0	0	0	0	0
Access																									W1	W1	W1	W1	W1	W1	W1	W1	W1	W1	W1	W1	W1	W1	W1	W1	W1	W1	W1	W1	W1	W1	W1	W1	W1	W1	W1	W1	W1	W1
Name																									CH7USEBURSTC	CH6USEBURSTC	CH5USEBURSTC	CH4USEBURSTC	CH3USEBURSTC	CH2USEBURSTC	CH1USEBURSTC	CH0USEBURSTC																						

Bit	Name	Reset	Access	Description
31:8	Reserved	<i>To ensure compatibility with future devices, always write bits to 0. More information in Section 2.1 (p. 3)</i>		
7	CH7USEBURSTC	0	W1	Channel 7 Useburst Clear Write to 1 to disable useburst setting for this channel.
6	CH6USEBURSTC	0	W1	Channel 6 Useburst Clear Write to 1 to disable useburst setting for this channel.
5	CH5USEBURSTC	0	W1	Channel 5 Useburst Clear Write to 1 to disable useburst setting for this channel.
4	CH4USEBURSTC	0	W1	Channel 4 Useburst Clear Write to 1 to disable useburst setting for this channel.
3	CH3USEBURSTC	0	W1	Channel 3 Useburst Clear Write to 1 to disable useburst setting for this channel.
2	CH2USEBURSTC	0	W1	Channel 2 Useburst Clear Write to 1 to disable useburst setting for this channel.
1	CH1USEBURSTC	0	W1	Channel 1 Useburst Clear Write to 1 to disable useburst setting for this channel.
0	CH0USEBURSTC	0	W1	Channel 0 Useburst Clear Write to 1 to disable useburst setting for this channel.

8.7.9 DMA_CHREQMASKS - Channel Request Mask Set Register

Offset	Bit Position																																																					
0x020	31	30	29	28	27	26	25	24	23	22	21	20	19	18	17	16	15	14	13	12	11	10	9	8	7	6	5	4	3	2	1	0																						
Reset																									0	0	0	0	0	0	0	0	0	0	0	0	0	0	0	0	0	0	0	0	0	0	0	0	0	0	0	0	0	0
Access																									RW1	RW1	RW1	RW1	RW1	RW1	RW1	RW1	RW1	RW1	RW1	RW1	RW1	RW1	RW1	RW1	RW1	RW1	RW1	RW1	RW1	RW1	RW1	RW1	RW1	RW1	RW1	RW1	RW1	RW1
Name																									CH7REQMASKS	CH6REQMASKS	CH5REQMASKS	CH4REQMASKS	CH3REQMASKS	CH2REQMASKS	CH1REQMASKS	CH0REQMASKS																						

Bit	Name	Reset	Access	Description
31:8	Reserved	To ensure compatibility with future devices, always write bits to 0. More information in Section 2.1 (p. 3)		
7	CH7REQMASKS	0	RW1	Channel 7 Request Mask Set Write to 1 to disable peripheral requests for this channel.
6	CH6REQMASKS	0	RW1	Channel 6 Request Mask Set Write to 1 to disable peripheral requests for this channel.
5	CH5REQMASKS	0	RW1	Channel 5 Request Mask Set Write to 1 to disable peripheral requests for this channel.
4	CH4REQMASKS	0	RW1	Channel 4 Request Mask Set Write to 1 to disable peripheral requests for this channel.
3	CH3REQMASKS	0	RW1	Channel 3 Request Mask Set Write to 1 to disable peripheral requests for this channel.
2	CH2REQMASKS	0	RW1	Channel 2 Request Mask Set Write to 1 to disable peripheral requests for this channel.
1	CH1REQMASKS	0	RW1	Channel 1 Request Mask Set Write to 1 to disable peripheral requests for this channel.
0	CH0REQMASKS	0	RW1	Channel 0 Request Mask Set Write to 1 to disable peripheral requests for this channel.

8.7.10 DMA_CHREQMASKC - Channel Request Mask Clear Register

Offset	Bit Position																																																					
0x024	31	30	29	28	27	26	25	24	23	22	21	20	19	18	17	16	15	14	13	12	11	10	9	8	7	6	5	4	3	2	1	0																						
Reset																									0	0	0	0	0	0	0	0	0	0	0	0	0	0	0	0	0	0	0	0	0	0	0	0	0	0	0	0	0	0
Access																									W1	W1	W1	W1	W1	W1	W1	W1	W1	W1	W1	W1	W1	W1	W1	W1	W1	W1	W1	W1	W1	W1	W1	W1	W1	W1	W1	W1	W1	W1
Name																									CH7REQMASKC	CH6REQMASKC	CH5REQMASKC	CH4REQMASKC	CH3REQMASKC	CH2REQMASKC	CH1REQMASKC	CH0REQMASKC																						

Bit	Name	Reset	Access	Description
31:8	Reserved	To ensure compatibility with future devices, always write bits to 0. More information in Section 2.1 (p. 3)		
7	CH7REQMASKC	0	W1	Channel 7 Request Mask Clear Write to 1 to enable peripheral requests for this channel.
6	CH6REQMASKC	0	W1	Channel 6 Request Mask Clear Write to 1 to enable peripheral requests for this channel.
5	CH5REQMASKC	0	W1	Channel 5 Request Mask Clear Write to 1 to enable peripheral requests for this channel.
4	CH4REQMASKC	0	W1	Channel 4 Request Mask Clear Write to 1 to enable peripheral requests for this channel.
3	CH3REQMASKC	0	W1	Channel 3 Request Mask Clear Write to 1 to enable peripheral requests for this channel.
2	CH2REQMASKC	0	W1	Channel 2 Request Mask Clear Write to 1 to enable peripheral requests for this channel.
1	CH1REQMASKC	0	W1	Channel 1 Request Mask Clear Write to 1 to enable peripheral requests for this channel.

Bit	Name	Reset	Access	Description
0	CH0REQMASKC	0	W1	Channel 0 Request Mask Clear Write to 1 to enable peripheral requests for this channel.

8.7.11 DMA_CHENS - Channel Enable Set Register

Offset	Bit Position																																																				
0x028	31	30	29	28	27	26	25	24	23	22	21	20	19	18	17	16	15	14	13	12	11	10	9	8	7	6	5	4	3	2	1	0																					
Reset																								0	0	0	0	0	0	0	0	0	0	0	0	0	0	0	0	0	0	0	0	0	0	0	0	0	0	0	0	0	0
Access																								RW1	RW1	RW1	RW1	RW1	RW1	RW1	RW1	RW1	RW1	RW1	RW1	RW1	RW1	RW1	RW1	RW1	RW1	RW1	RW1	RW1	RW1	RW1	RW1	RW1	RW1	RW1	RW1	RW1	RW1
Name																								CH7ENS	CH6ENS	CH5ENS	CH4ENS	CH3ENS	CH2ENS	CH1ENS	CH0ENS																						

Bit	Name	Reset	Access	Description
31:8	<i>Reserved</i>	<i>To ensure compatibility with future devices, always write bits to 0. More information in Section 2.1 (p. 3)</i>		
7	CH7ENS	0	RW1	Channel 7 Enable Set Write to 1 to enable this channel. Reading returns the enable status of the channel.
6	CH6ENS	0	RW1	Channel 6 Enable Set Write to 1 to enable this channel. Reading returns the enable status of the channel.
5	CH5ENS	0	RW1	Channel 5 Enable Set Write to 1 to enable this channel. Reading returns the enable status of the channel.
4	CH4ENS	0	RW1	Channel 4 Enable Set Write to 1 to enable this channel. Reading returns the enable status of the channel.
3	CH3ENS	0	RW1	Channel 3 Enable Set Write to 1 to enable this channel. Reading returns the enable status of the channel.
2	CH2ENS	0	RW1	Channel 2 Enable Set Write to 1 to enable this channel. Reading returns the enable status of the channel.
1	CH1ENS	0	RW1	Channel 1 Enable Set Write to 1 to enable this channel. Reading returns the enable status of the channel.
0	CH0ENS	0	RW1	Channel 0 Enable Set Write to 1 to enable this channel. Reading returns the enable status of the channel.

8.7.12 DMA_CHENC - Channel Enable Clear Register

Offset	Bit Position																																																				
0x02C	31	30	29	28	27	26	25	24	23	22	21	20	19	18	17	16	15	14	13	12	11	10	9	8	7	6	5	4	3	2	1	0																					
Reset																								0	0	0	0	0	0	0	0	0	0	0	0	0	0	0	0	0	0	0	0	0	0	0	0	0	0	0	0	0	0
Access																								W1	W1	W1	W1	W1	W1	W1	W1	W1	W1	W1	W1	W1	W1	W1	W1	W1	W1	W1	W1	W1	W1	W1	W1	W1	W1	W1	W1	W1	W1
Name																								CH7ENC	CH6ENC	CH5ENC	CH4ENC	CH3ENC	CH2ENC	CH1ENC	CH0ENC																						

Bit	Name	Reset	Access	Description
31:8	<i>Reserved</i>	<i>To ensure compatibility with future devices, always write bits to 0. More information in Section 2.1 (p. 3)</i>		

Bit	Name	Reset	Access	Description
7	CH7ENC	0	W1	Channel 7 Enable Clear Write to 1 to disable this channel. See also description for channel 0.
6	CH6ENC	0	W1	Channel 6 Enable Clear Write to 1 to disable this channel. See also description for channel 0.
5	CH5ENC	0	W1	Channel 5 Enable Clear Write to 1 to disable this channel. See also description for channel 0.
4	CH4ENC	0	W1	Channel 4 Enable Clear Write to 1 to disable this channel. See also description for channel 0.
3	CH3ENC	0	W1	Channel 3 Enable Clear Write to 1 to disable this channel. See also description for channel 0.
2	CH2ENC	0	W1	Channel 2 Enable Clear Write to 1 to disable this channel. See also description for channel 0.
1	CH1ENC	0	W1	Channel 1 Enable Clear Write to 1 to disable this channel. See also description for channel 0.
0	CH0ENC	0	W1	Channel 0 Enable Clear Write to 1 to disable this channel. Note that the controller disables a channel, by setting the appropriate bit, when either it completes the DMA cycle, or it reads a channel_cfg memory location which has cycle_ctrl = b000, or an ERROR occurs on the AHB-Lite bus.

8.7.13 DMA_CHALTS - Channel Alternate Set Register

Offset	Bit Position																																																	
0x030	31	30	29	28	27	26	25	24	23	22	21	20	19	18	17	16	15	14	13	12	11	10	9	8	7	6	5	4	3	2	1	0																		
Reset																			0	0	0	0	0	0	0	0	0	0	0	0	0	0	0	0	0	0	0	0	0	0	0	0	0	0	0	0	0	0	0	
Access																			RW1	RW1	RW1	RW1	RW1	RW1	RW1	RW1	RW1	RW1	RW1	RW1	RW1	RW1	RW1	RW1	RW1	RW1	RW1	RW1	RW1	RW1	RW1	RW1	RW1	RW1	RW1	RW1	RW1	RW1	RW1	RW1
Name																			CH7ALTS	CH6ALTS	CH5ALTS	CH4ALTS	CH3ALTS	CH2ALTS	CH1ALTS	CH0ALTS																								

Bit	Name	Reset	Access	Description
31:8	<i>Reserved</i>	<i>To ensure compatibility with future devices, always write bits to 0. More information in Section 2.1 (p. 3)</i>		
7	CH7ALTS	0	RW1	Channel 7 Alternate Structure Set Write to 1 to select the alternate structure for this channel.
6	CH6ALTS	0	RW1	Channel 6 Alternate Structure Set Write to 1 to select the alternate structure for this channel.
5	CH5ALTS	0	RW1	Channel 5 Alternate Structure Set Write to 1 to select the alternate structure for this channel.
4	CH4ALTS	0	RW1	Channel 4 Alternate Structure Set Write to 1 to select the alternate structure for this channel.
3	CH3ALTS	0	RW1	Channel 3 Alternate Structure Set Write to 1 to select the alternate structure for this channel.
2	CH2ALTS	0	RW1	Channel 2 Alternate Structure Set Write to 1 to select the alternate structure for this channel.
1	CH1ALTS	0	RW1	Channel 1 Alternate Structure Set Write to 1 to select the alternate structure for this channel.
0	CH0ALTS	0	RW1	Channel 0 Alternate Structure Set

Bit	Name	Reset	Access	Description
7	CH7PRIS	0	RW1	Channel 7 High Priority Set Write to 1 to obtain high priority for this channel. Reading returns the channel priority status.
6	CH6PRIS	0	RW1	Channel 6 High Priority Set Write to 1 to obtain high priority for this channel. Reading returns the channel priority status.
5	CH5PRIS	0	RW1	Channel 5 High Priority Set Write to 1 to obtain high priority for this channel. Reading returns the channel priority status.
4	CH4PRIS	0	RW1	Channel 4 High Priority Set Write to 1 to obtain high priority for this channel. Reading returns the channel priority status.
3	CH3PRIS	0	RW1	Channel 3 High Priority Set Write to 1 to obtain high priority for this channel. Reading returns the channel priority status.
2	CH2PRIS	0	RW1	Channel 2 High Priority Set Write to 1 to obtain high priority for this channel. Reading returns the channel priority status.
1	CH1PRIS	0	RW1	Channel 1 High Priority Set Write to 1 to obtain high priority for this channel. Reading returns the channel priority status.
0	CH0PRIS	0	RW1	Channel 0 High Priority Set Write to 1 to obtain high priority for this channel. Reading returns the channel priority status.

8.7.16 DMA_CHPRIC - Channel Priority Clear Register

Offset	Bit Position																																		
0x03C	31	30	29	28	27	26	25	24	23	22	21	20	19	18	17	16	15	14	13	12	11	10	9	8	7	6	5	4	3	2	1	0			
Reset																	0	0	0	0	0	0	0	0	0	0	0	0	0	0	0	0	0	0	
Access																	W1	W1	W1	W1	W1	W1	W1	W1	W1	W1	W1	W1	W1	W1	W1	W1	W1	W1	
Name																	CH7PRIC	CH6PRIC	CH5PRIC	CH4PRIC	CH3PRIC	CH2PRIC	CH1PRIC	CH0PRIC											

Bit	Name	Reset	Access	Description
31:8	<i>Reserved</i>	<i>To ensure compatibility with future devices, always write bits to 0. More information in Section 2.1 (p. 3)</i>		
7	CH7PRIC	0	W1	Channel 7 High Priority Clear Write to 1 to clear high priority for this channel.
6	CH6PRIC	0	W1	Channel 6 High Priority Clear Write to 1 to clear high priority for this channel.
5	CH5PRIC	0	W1	Channel 5 High Priority Clear Write to 1 to clear high priority for this channel.
4	CH4PRIC	0	W1	Channel 4 High Priority Clear Write to 1 to clear high priority for this channel.
3	CH3PRIC	0	W1	Channel 3 High Priority Clear Write to 1 to clear high priority for this channel.
2	CH2PRIC	0	W1	Channel 2 High Priority Clear Write to 1 to clear high priority for this channel.
1	CH1PRIC	0	W1	Channel 1 High Priority Clear Write to 1 to clear high priority for this channel.
0	CH0PRIC	0	W1	Channel 0 High Priority Clear

Bit	Name	Reset	Access	Description
				Write to 1 to clear high priority for this channel.

8.7.17 DMA_ERRORC - Bus Error Clear Register

Offset	Bit Position																															
0x04C	31	30	29	28	27	26	25	24	23	22	21	20	19	18	17	16	15	14	13	12	11	10	9	8	7	6	5	4	3	2	1	0
Reset																																0
Access																																RW
Name																																ERRORC

Bit	Name	Reset	Access	Description
31:1	Reserved	To ensure compatibility with future devices, always write bits to 0. More information in Section 2.1 (p. 3)		
0	ERRORC	0	RW	Bus Error Clear This bit is set high if an AHB bus error has occurred. Writing a 1 to this bit will clear the bit. If the error is deasserted at the same time as an error occurs on the bus, the error condition takes precedence and ERRORC remains asserted.

8.7.18 DMA_CHREQSTATUS - Channel Request Status

Offset	Bit Position																															
0xE10	31	30	29	28	27	26	25	24	23	22	21	20	19	18	17	16	15	14	13	12	11	10	9	8	7	6	5	4	3	2	1	0
Reset																																0
Access																																R
Name																																CH7REQSTATUS CH6REQSTATUS CH5REQSTATUS CH4REQSTATUS CH3REQSTATUS CH2REQSTATUS CH1REQSTATUS CH0REQSTATUS

Bit	Name	Reset	Access	Description
31:8	Reserved	To ensure compatibility with future devices, always write bits to 0. More information in Section 2.1 (p. 3)		
7	CH7REQSTATUS	0	R	Channel 7 Request Status When this bit is 1, it indicates that the peripheral connected as the input to this DMA channel is requesting the controller to service the DMA channel. The controller services the request by performing the DMA cycle using 2 ^R DMA transfers.
6	CH6REQSTATUS	0	R	Channel 6 Request Status When this bit is 1, it indicates that the peripheral connected as the input to this DMA channel is requesting the controller to service the DMA channel. The controller services the request by performing the DMA cycle using 2 ^R DMA transfers.
5	CH5REQSTATUS	0	R	Channel 5 Request Status When this bit is 1, it indicates that the peripheral connected as the input to this DMA channel is requesting the controller to service the DMA channel. The controller services the request by performing the DMA cycle using 2 ^R DMA transfers.
4	CH4REQSTATUS	0	R	Channel 4 Request Status When this bit is 1, it indicates that the peripheral connected as the input to this DMA channel is requesting the controller to service the DMA channel. The controller services the request by performing the DMA cycle using 2 ^R DMA transfers.
3	CH3REQSTATUS	0	R	Channel 3 Request Status

Bit	Name	Reset	Access	Description
				When this bit is 1, it indicates that the peripheral connected as the input to this DMA channel is requesting the controller to service the DMA channel. The controller services the request by performing the DMA cycle using 2 ^R DMA transfers.
2	CH2REQSTATUS	0	R	Channel 2 Request Status When this bit is 1, it indicates that the peripheral connected as the input to this DMA channel is requesting the controller to service the DMA channel. The controller services the request by performing the DMA cycle using 2 ^R DMA transfers.
1	CH1REQSTATUS	0	R	Channel 1 Request Status When this bit is 1, it indicates that the peripheral connected as the input to this DMA channel is requesting the controller to service the DMA channel. The controller services the request by performing the DMA cycle using 2 ^R DMA transfers.
0	CH0REQSTATUS	0	R	Channel 0 Request Status When this bit is 1, it indicates that the peripheral connected as the input to this DMA channel is requesting the controller to service the DMA channel. The controller services the request by performing the DMA cycle using 2 ^R DMA transfers.

8.7.19 DMA_CHSREQSTATUS - Channel Single Request Status

Offset	Bit Position																																																	
0xE18	31	30	29	28	27	26	25	24	23	22	21	20	19	18	17	16	15	14	13	12	11	10	9	8	7	6	5	4	3	2	1	0																		
Reset																	R	0	R	0	R	0	R	0	R	0	R	0	R	0	R	0	R	0	R	0	R	0	R	0	R	0	R	0	R	0				
Access																	R		R		R		R		R		R		R		R		R		R		R		R		R		R		R		R		R	
Name																	CH7SREQSTATUS	CH6SREQSTATUS	CH5SREQSTATUS	CH4SREQSTATUS	CH3SREQSTATUS	CH2SREQSTATUS	CH1SREQSTATUS	CH0SREQSTATUS																										

Bit	Name	Reset	Access	Description
31:8	Reserved	To ensure compatibility with future devices, always write bits to 0. More information in Section 2.1 (p. 3)		
7	CH7SREQSTATUS	0	R	Channel 7 Single Request Status When this bit is 1, it indicates that the peripheral connected as the input to this DMA channel is requesting the controller to service the DMA channel. The controller services the request by performing the DMA cycle using single DMA transfers.
6	CH6SREQSTATUS	0	R	Channel 6 Single Request Status When this bit is 1, it indicates that the peripheral connected as the input to this DMA channel is requesting the controller to service the DMA channel. The controller services the request by performing the DMA cycle using single DMA transfers.
5	CH5SREQSTATUS	0	R	Channel 5 Single Request Status When this bit is 1, it indicates that the peripheral connected as the input to this DMA channel is requesting the controller to service the DMA channel. The controller services the request by performing the DMA cycle using single DMA transfers.
4	CH4SREQSTATUS	0	R	Channel 4 Single Request Status When this bit is 1, it indicates that the peripheral connected as the input to this DMA channel is requesting the controller to service the DMA channel. The controller services the request by performing the DMA cycle using single DMA transfers.
3	CH3SREQSTATUS	0	R	Channel 3 Single Request Status When this bit is 1, it indicates that the peripheral connected as the input to this DMA channel is requesting the controller to service the DMA channel. The controller services the request by performing the DMA cycle using single DMA transfers.
2	CH2SREQSTATUS	0	R	Channel 2 Single Request Status When this bit is 1, it indicates that the peripheral connected as the input to this DMA channel is requesting the controller to service the DMA channel. The controller services the request by performing the DMA cycle using single DMA transfers.
1	CH1SREQSTATUS	0	R	Channel 1 Single Request Status When this bit is 1, it indicates that the peripheral connected as the input to this DMA channel is requesting the controller to service the DMA channel. The controller services the request by performing the DMA cycle using single DMA transfers.
0	CH0SREQSTATUS	0	R	Channel 0 Single Request Status When this bit is 1, it indicates that the peripheral connected as the input to this DMA channel is requesting the controller to service the DMA channel. The controller services the request by performing the DMA cycle using single DMA transfers.

8.7.20 DMA_IF - Interrupt Flag Register

Offset	Bit Position																																
0x1000	31	30	29	28	27	26	25	24	23	22	21	20	19	18	17	16	15	14	13	12	11	10	9	8	7	6	5	4	3	2	1	0	
Reset	0																									0	0	0	0	0	0	0	0
Access	R																									R	R	R	R	R	R	R	R
Name	ERR																									CH7DONE	CH6DONE	CH5DONE	CH4DONE	CH3DONE	CH2DONE	CH1DONE	CH0DONE

Bit	Name	Reset	Access	Description
31	ERR	0	R	DMA Error Interrupt Flag This flag is set when an error has occurred on the AHB bus.
30:8	<i>Reserved</i>	<i>To ensure compatibility with future devices, always write bits to 0. More information in Section 2.1 (p. 3)</i>		
7	CH7DONE	0	R	DMA Channel 7 Complete Interrupt Flag Set when the DMA channel has completed its transfer. If the channel is disabled, the flag is set when there is a request for the channel.
6	CH6DONE	0	R	DMA Channel 6 Complete Interrupt Flag Set when the DMA channel has completed its transfer. If the channel is disabled, the flag is set when there is a request for the channel.
5	CH5DONE	0	R	DMA Channel 5 Complete Interrupt Flag Set when the DMA channel has completed its transfer. If the channel is disabled, the flag is set when there is a request for the channel.
4	CH4DONE	0	R	DMA Channel 4 Complete Interrupt Flag Set when the DMA channel has completed its transfer. If the channel is disabled, the flag is set when there is a request for the channel.
3	CH3DONE	0	R	DMA Channel 3 Complete Interrupt Flag Set when the DMA channel has completed its transfer. If the channel is disabled, the flag is set when there is a request for the channel.
2	CH2DONE	0	R	DMA Channel 2 Complete Interrupt Flag Set when the DMA channel has completed its transfer. If the channel is disabled, the flag is set when there is a request for the channel.
1	CH1DONE	0	R	DMA Channel 1 Complete Interrupt Flag Set when the DMA channel has completed its transfer. If the channel is disabled, the flag is set when there is a request for the channel.
0	CH0DONE	0	R	DMA Channel 0 Complete Interrupt Flag Set when the DMA channel has completed its transfer. If the channel is disabled, the flag is set when there is a request for the channel.

8.7.21 DMA_IFS - Interrupt Flag Set Register

Offset	Bit Position																																
0x1004	31	30	29	28	27	26	25	24	23	22	21	20	19	18	17	16	15	14	13	12	11	10	9	8	7	6	5	4	3	2	1	0	
Reset	0																									0	0	0	0	0	0	0	0
Access	W1																									W1	W1	W1	W1	W1	W1	W1	W1
Name	ERR																									CH7DONE	CH6DONE	CH5DONE	CH4DONE	CH3DONE	CH2DONE	CH1DONE	CH0DONE

Bit	Name	Reset	Access	Description
31	ERR	0	W1	DMA Error Interrupt Flag Set Set to 1 to set DMA error interrupt flag.
30:8	<i>Reserved</i>	<i>To ensure compatibility with future devices, always write bits to 0. More information in Section 2.1 (p. 3)</i>		
7	CH7DONE	0	W1	DMA Channel 7 Complete Interrupt Flag Set Write to 1 to set the corresponding DMA channel complete interrupt flag.

Bit	Name	Reset	Access	Description
6	CH6DONE	0	W1	DMA Channel 6 Complete Interrupt Flag Set Write to 1 to set the corresponding DMA channel complete interrupt flag.
5	CH5DONE	0	W1	DMA Channel 5 Complete Interrupt Flag Set Write to 1 to set the corresponding DMA channel complete interrupt flag.
4	CH4DONE	0	W1	DMA Channel 4 Complete Interrupt Flag Set Write to 1 to set the corresponding DMA channel complete interrupt flag.
3	CH3DONE	0	W1	DMA Channel 3 Complete Interrupt Flag Set Write to 1 to set the corresponding DMA channel complete interrupt flag.
2	CH2DONE	0	W1	DMA Channel 2 Complete Interrupt Flag Set Write to 1 to set the corresponding DMA channel complete interrupt flag.
1	CH1DONE	0	W1	DMA Channel 1 Complete Interrupt Flag Set Write to 1 to set the corresponding DMA channel complete interrupt flag.
0	CH0DONE	0	W1	DMA Channel 0 Complete Interrupt Flag Set Write to 1 to set the corresponding DMA channel complete interrupt flag.

8.7.22 DMA_IFC - Interrupt Flag Clear Register

Offset	Bit Position																																
	31	30	29	28	27	26	25	24	23	22	21	20	19	18	17	16	15	14	13	12	11	10	9	8	7	6	5	4	3	2	1	0	
0x1008	0																																
Reset	0																									0	0	0	0	0	0	0	0
Access	W1																									W1	W1	W1	W1	W1	W1	W1	W1
Name	ERR																									CH7DONE	CH6DONE	CH5DONE	CH4DONE	CH3DONE	CH2DONE	CH1DONE	CH0DONE

Bit	Name	Reset	Access	Description
31	ERR	0	W1	DMA Error Interrupt Flag Clear Set to 1 to clear DMA error interrupt flag. Note that if an error happened, the Bus Error Clear Register must be used to clear the DMA.
30:8	<i>Reserved</i>	<i>To ensure compatibility with future devices, always write bits to 0. More information in Section 2.1 (p. 3)</i>		
7	CH7DONE	0	W1	DMA Channel 7 Complete Interrupt Flag Clear Write to 1 to clear the corresponding DMA channel complete interrupt flag.
6	CH6DONE	0	W1	DMA Channel 6 Complete Interrupt Flag Clear Write to 1 to clear the corresponding DMA channel complete interrupt flag.
5	CH5DONE	0	W1	DMA Channel 5 Complete Interrupt Flag Clear Write to 1 to clear the corresponding DMA channel complete interrupt flag.
4	CH4DONE	0	W1	DMA Channel 4 Complete Interrupt Flag Clear Write to 1 to clear the corresponding DMA channel complete interrupt flag.
3	CH3DONE	0	W1	DMA Channel 3 Complete Interrupt Flag Clear Write to 1 to clear the corresponding DMA channel complete interrupt flag.
2	CH2DONE	0	W1	DMA Channel 2 Complete Interrupt Flag Clear Write to 1 to clear the corresponding DMA channel complete interrupt flag.
1	CH1DONE	0	W1	DMA Channel 1 Complete Interrupt Flag Clear Write to 1 to clear the corresponding DMA channel complete interrupt flag.
0	CH0DONE	0	W1	DMA Channel 0 Complete Interrupt Flag Clear Write to 1 to clear the corresponding DMA channel complete interrupt flag.

8.7.23 DMA_IEN - Interrupt Enable register

Offset	Bit Position																																
0x100C	31	30	29	28	27	26	25	24	23	22	21	20	19	18	17	16	15	14	13	12	11	10	9	8	7	6	5	4	3	2	1	0	
Reset	0																									0	0	0	0	0	0	0	0
Access	RW																									RW	RW	RW	RW	RW	RW	RW	RW
Name	ERR																									CH7DONE	CH6DONE	CH5DONE	CH4DONE	CH3DONE	CH2DONE	CH1DONE	CH0DONE

Bit	Name	Reset	Access	Description
31	ERR	0	RW	DMA Error Interrupt Flag Enable Set this bit to enable interrupt on AHB bus error.
30:8	Reserved	To ensure compatibility with future devices, always write bits to 0. More information in Section 2.1 (p. 3)		
7	CH7DONE	0	RW	DMA Channel 7 Complete Interrupt Enable Write to 1 to enable complete interrupt on this DMA channel. Clear to disable the interrupt.
6	CH6DONE	0	RW	DMA Channel 6 Complete Interrupt Enable Write to 1 to enable complete interrupt on this DMA channel. Clear to disable the interrupt.
5	CH5DONE	0	RW	DMA Channel 5 Complete Interrupt Enable Write to 1 to enable complete interrupt on this DMA channel. Clear to disable the interrupt.
4	CH4DONE	0	RW	DMA Channel 4 Complete Interrupt Enable Write to 1 to enable complete interrupt on this DMA channel. Clear to disable the interrupt.
3	CH3DONE	0	RW	DMA Channel 3 Complete Interrupt Enable Write to 1 to enable complete interrupt on this DMA channel. Clear to disable the interrupt.
2	CH2DONE	0	RW	DMA Channel 2 Complete Interrupt Enable Write to 1 to enable complete interrupt on this DMA channel. Clear to disable the interrupt.
1	CH1DONE	0	RW	DMA Channel 1 Complete Interrupt Enable Write to 1 to enable complete interrupt on this DMA channel. Clear to disable the interrupt.
0	CH0DONE	0	RW	DMA Channel 0 Complete Interrupt Enable Write to 1 to enable complete interrupt on this DMA channel. Clear to disable the interrupt.

8.7.24 DMA_CHx_CTRL - Channel Control Register

Offset	Bit Position																															
0x1100	31	30	29	28	27	26	25	24	23	22	21	20	19	18	17	16	15	14	13	12	11	10	9	8	7	6	5	4	3	2	1	0
Reset												0x00																				
Access												RW																				
Name												SOURCESEL											SIGSEL									

Bit	Name	Reset	Access	Description
31:22	Reserved	To ensure compatibility with future devices, always write bits to 0. More information in Section 2.1 (p. 3)		
21:16	SOURCESEL	0x00	RW	Source Select Select input source to DMA channel.

Bit	Name	Reset	Access	Description
	Value	Mode		Description
	0b000000	NONE		No source selected
	0b001000	ADC0		Analog to Digital Converter 0
	0b001010	DAC0		Digital to Analog Converter 0
	0b001100	USART0		Universal Synchronous/Asynchronous Receiver/Transmitter 0
	0b001101	USART1		Universal Synchronous/Asynchronous Receiver/Transmitter 1
	0b001110	USART2		Universal Synchronous/Asynchronous Receiver/Transmitter 2
	0b010000	LEUART0		Low Energy UART 0
	0b010001	LEUART1		Low Energy UART 1
	0b010100	I2C0		I2C 0
	0b011000	TIMER0		Timer 0
	0b011001	TIMER1		Timer 1
	0b011010	TIMER2		Timer 2
	0b101100	UART0		Universal Asynchronous Receiver/Transmitter 0
	0b110000	MSC		
	0b110001	AES		Advanced Encryption Standard Accelerator

15:4 *Reserved* *To ensure compatibility with future devices, always write bits to 0. More information in Section 2.1 (p. 3)*

3:0 **SIGSEL** 0x0 RW **Signal Select**

Select input signal to DMA channel.

Value	Mode	Description
SOURCESEL = 0b000000 (NONE)		
0bxxxx	OFF	Channel input selection is turned off
SOURCESEL = 0b001000 (ADC0)		
0b0000	ADC0SINGLE	ADC0SINGLE
0b0001	ADC0SCAN	ADC0SCAN
SOURCESEL = 0b001010 (DAC0)		
0b0000	DAC0CH0	DAC0CH0
0b0001	DAC0CH1	DAC0CH1
SOURCESEL = 0b001100 (USART0)		
0b0000	USART0RXDATAV	USART0RXDATAV REQ/SREQ
0b0001	USART0TXBL	USART0TXBL REQ/SREQ
0b0010	USART0TXEMPTY	USART0TXEMPTY
SOURCESEL = 0b001101 (USART1)		
0b0000	USART1RXDATAV	USART1RXDATAV REQ/SREQ
0b0001	USART1TXBL	USART1TXBL REQ/SREQ
0b0010	USART1TXEMPTY	USART1TXEMPTY
SOURCESEL = 0b001110 (USART2)		
0b0000	USART2RXDATAV	USART2RXDATAV REQ/SREQ
0b0001	USART2TXBL	USART2TXBL REQ/SREQ
0b0010	USART2TXEMPTY	USART2TXEMPTY
SOURCESEL = 0b010000 (LEUART0)		
0b0000	LEUART0RXDATAV	LEUART0RXDATAV
0b0001	LEUART0TXBL	LEUART0TXBL
0b0010	LEUART0TXEMPTY	LEUART0TXEMPTY
SOURCESEL = 0b010001 (LEUART1)		
0b0000	LEUART1RXDATAV	LEUART1RXDATAV
0b0001	LEUART1TXBL	LEUART1TXBL
0b0010	LEUART1TXEMPTY	LEUART1TXEMPTY
SOURCESEL = 0b010100 (I2C0)		
0b0000	I2C0RXDATAV	I2C0RXDATAV
0b0001	I2C0TXBL	I2C0TXBL

Bit	Name	Reset	Access	Description
	Value	Mode		Description
	SOURCESEL = 0b011000 (TIMER0)			
	0b0000	TIMER0UFOF		TIMER0UFOF
	0b0001	TIMER0CC0		TIMER0CC0
	0b0010	TIMER0CC1		TIMER0CC1
	0b0011	TIMER0CC2		TIMER0CC2
	SOURCESEL = 0b011001 (TIMER1)			
	0b0000	TIMER1UFOF		TIMER1UFOF
	0b0001	TIMER1CC0		TIMER1CC0
	0b0010	TIMER1CC1		TIMER1CC1
	0b0011	TIMER1CC2		TIMER1CC2
	SOURCESEL = 0b011010 (TIMER2)			
	0b0000	TIMER2UFOF		TIMER2UFOF
	0b0001	TIMER2CC0		TIMER2CC0
	0b0010	TIMER2CC1		TIMER2CC1
	0b0011	TIMER2CC2		TIMER2CC2
	SOURCESEL = 0b101100 (UART0)			
	0b0000	UART0RXDATAV		UART0RXDATAV REQ/SREQ
	0b0001	UART0TXBL		UART0TXBL REQ/SREQ
	0b0010	UART0TXEMPTY		UART0TXEMPTY
	SOURCESEL = 0b110000 (MSC)			
	0b0000	MSCWDATA		MSCWDATA
	SOURCESEL = 0b110001 (AES)			
	0b0000	AESDATAWR		AESDATAWR
	0b0001	AESXORDATAWR		AESXORDATAWR
	0b0010	AESDATARD		AESDATARD
	0b0011	AESKEYWR		AESKEYWR

9 RMU - Reset Management Unit

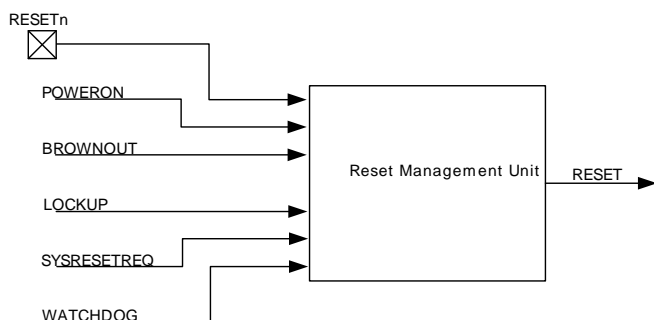
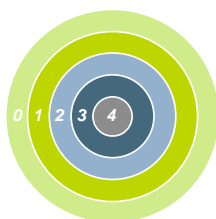

Quick Facts

What?

The RMU ensures correct reset operation. It is responsible for connecting the different reset sources to the reset lines of the EFM32G.

Why?

A correct reset sequence is needed to ensure safe and synchronous startup of the EFM32G. In the case of error situations such as power supply glitches or software crash, the RMU provides proper reset and startup of the EFM32G.

How?

The Power-on Reset and Brown-out Detector of the EFM32G provides power line monitoring with exceptionally low power consumption. The cause of the reset may be read from a register, thus providing software with information about the cause of the reset.

9.1 Introduction

The RMU is responsible for handling the reset functionality of the EFM32G.

9.2 Features

- Reset sources
 - Power-on Reset (POR)
 - Brown-out Detection (BOD)
 - RESETn pin reset
 - Watchdog reset
 - Software triggered reset (SYSRESETREQ)
 - Core LOCKUP condition
- A software readable register indicates the cause of the last reset

9.3 Functional Description

The RMU monitors each of the reset sources of the EFM32G. If one or more reset sources go active, the RMU applies reset to the EFM32G. When the reset sources go inactive the EFM32G starts up. At startup the EFM32G loads the stack pointer and program entry point from memory, and starts execution.

As seen in Figure 9.1 (p. 78) the Power-on Reset, Brown-out Detectors and RESETn pin all reset the whole system including the Debug Interface. A Watch Dog timeout, a Core Lockup condition or a System reset request from software resets the whole system except the Debug Interface.

Whenever a reset source is active, the corresponding bit in the RMU_RSTCAUSE register is set. At startup the program code may investigate this register in order to determine the cause of the reset. The register must be cleared by software.

Figure 9.1. RMU Reset Input Sources and Connections.

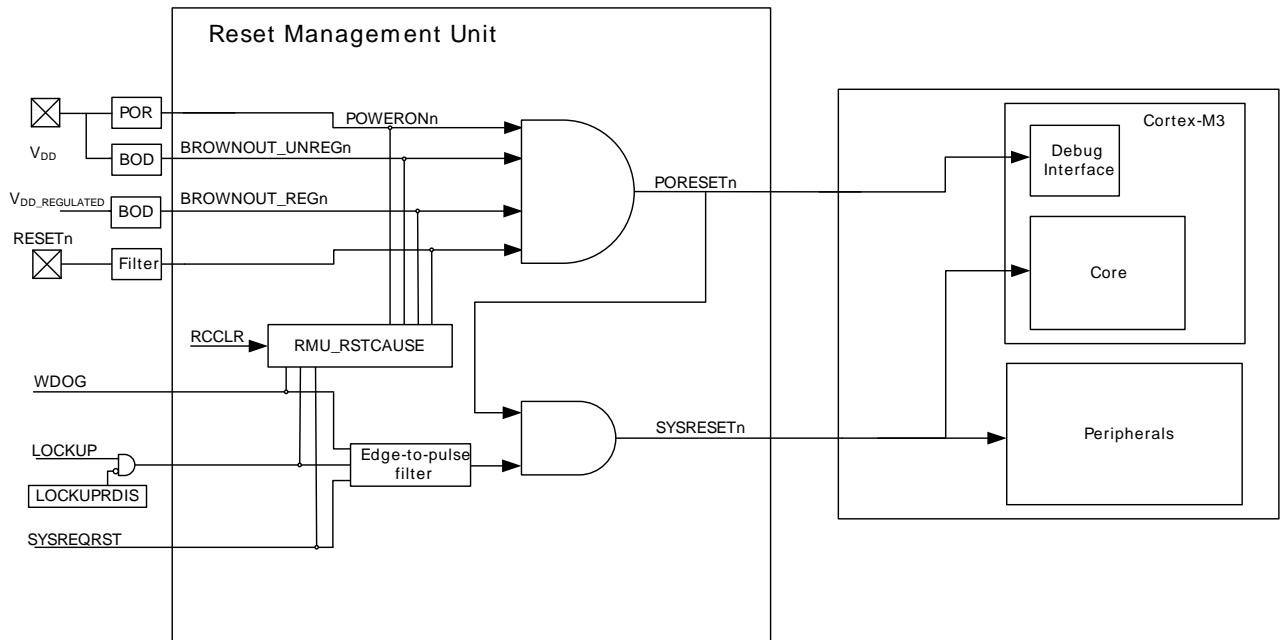

9.3.1 RMU_RSTCAUSE Register

The RMU_RSTCAUSE register indicates the reason for the last reset. The register should be cleared after the value has been read at startup. Otherwise the register may indicate multiple causes for the reset at next startup. The following procedure must be done to clear RMU_RSTCAUSE:

1. Write a 1 to RCCLR in RMU_CMD
2. Write a 1 to bit 0 in EMU_AUXCTRL
3. Write a 0 to bit 0 in EMU_AUXCTRL

RMU_RSTCAUSE should be interpreted according to Table 9.1 (p. 78). X bits are don't care. Notice that it is possible to have multiple reset causes. For example, an external reset and a watchdog reset may happen simultaneously.

Table 9.1. RMU Reset Cause Register Interpretation

Register Value	Cause
0bXXX XXX1	A Power-on Reset has been performed. X bits are don't care.
0bXXX XX10	A Brown-out has been detected on the unregulated power.
0bXX0 0100	A Brown-out has been detected on the regulated power.
0bXXX 1X00	An external reset has been applied.
0bXX1 XX00	A watchdog reset has occurred.
0bX10 0000	A lockup reset has occurred.
0b1X0 0000	A system request reset has occurred.

Note

When exiting EM4 with external reset, both the BODREGRST and BODUNREGRST in RSTCAUSE might be set (i.e. are invalid)

9.3.2 Power-On Reset (POR)

The POR ensures that the EFM32G does not start up before the supply voltage V_{DD} has reached the threshold voltage V_{PORthr} (see Device Datasheet Electrical Characteristics for details). Before the

threshold voltage is reached, the EFM32G is kept in reset state. The operation of the POR is illustrated in Figure 9.2 (p. 79), with the active low POWERONn reset signal. The reason for the “unknown” region is that the corresponding supply voltage is too low for any reliable operation.

Figure 9.2. RMU Power-on Reset Operation

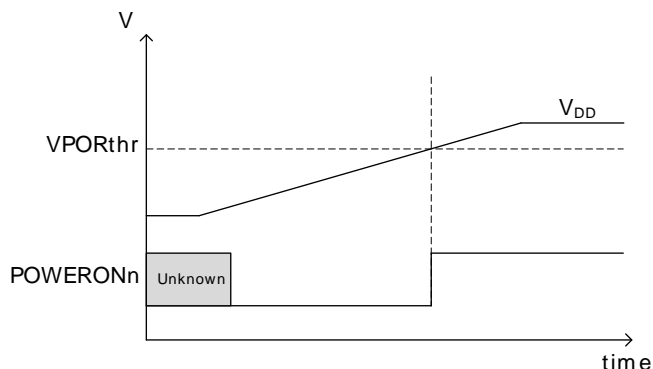

9.3.3 Brown-Out Detector Reset (BOD)

The EFM32G has 2 brownout detectors, one for the unregulated 3.0 V power and one for the internal 1.8 V power. The BODs are constantly monitoring the voltages. Whenever the voltage is below the VBODthr value (see Electrical Characteristics for details), the corresponding active low BROWNOUTn line is held low. The BODs also include hysteresis, which prevents instability in the corresponding BROWNOUTn line when the supply is crossing the VBODthr limit. The operation of the BOD is illustrated in Figure 9.3 (p. 79). The “unknown” regions are handled by the POR module.

Figure 9.3. RMU Brown-out Detector Operation

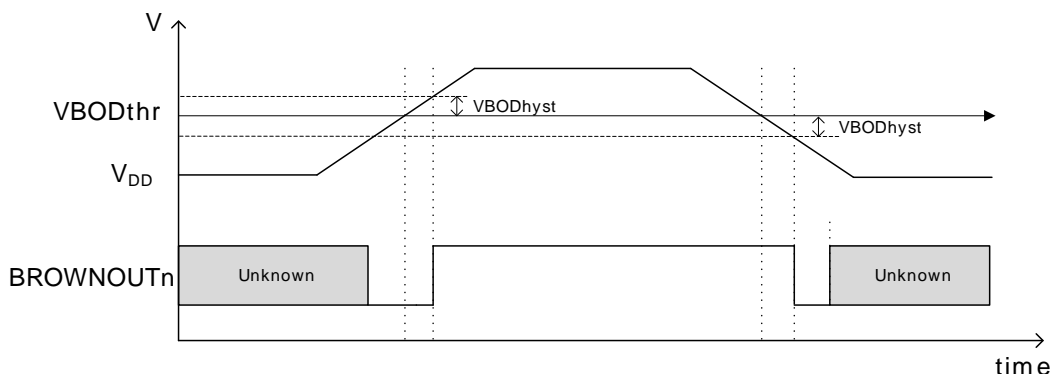

9.3.4 RESEn pin Reset

Forcing the RESEn pin low generates a reset of the EFM32G. The RESEn pin includes an on-chip pull-up resistor, and can therefore be left unconnected if no external reset source is needed. Also connected to the RESEn line is a filter which prevents glitches from resetting the EFM32G.

9.3.5 Watchdog Reset

The Watchdog circuit is a timer which (when enabled) must be cleared by software regularly. If software does not clear it, a Watchdog reset is activated. This functionality provides recovery from a software stalemate. Refer to the Watchdog section for specifications and description. A Watchdog reset does not reset the Debug Interface. This allows an active debug session to continue in case of a Watchdog reset.

9.3.6 Lockup Reset

A Cortex-M3 lockup is the result of the core being locked up because of an unrecoverable exception following the activation of the processor’s built-in system state protection hardware.

A Cortex-M3 lockup gives immediate indication of seriously errant kernel software. This is the result of the core being locked up due to an unrecoverable exception following the activation of the processor's built in system state protection hardware. For more information about the Cortex-M3 lockup conditions see the ARMv7-M Architecture Reference Manual. The Lockup reset does not reset the Debug Interface. Set the LOCKUPRDIS bit in the RMU_CTRL register in order to disable this reset source.

9.3.7 System Reset Request

Software may initiate a reset (e.g. if it finds itself in a non-recoverable state). By asserting the SYSRESETREQ in the Application Interrupt and Reset Control Register (write 0x05FA 0004), a reset is issued. The SYSRESETREQ does not reset the Debug Interface.

9.4 Register Map

The offset register address is relative to the registers base address.

Offset	Name	Type	Description
0x000	RMU_CTRL	RW	Control Register
0x004	RMU_RSTCAUSE	R	Reset Cause Register
0x008	RMU_CMD	W1	Command Register

9.5 Register Description

9.5.1 RMU_CTRL - Control Register

Offset	Bit Position																															
0x000	31	30	29	28	27	26	25	24	23	22	21	20	19	18	17	16	15	14	13	12	11	10	9	8	7	6	5	4	3	2	1	0
Reset																																0
Access																																RW
Name																																LOCKUPRDIS

Bit	Name	Reset	Access	Description
31:1	Reserved	To ensure compatibility with future devices, always write bits to 0. More information in Section 2.1 (p. 3)		
0	LOCKUPRDIS	0	RW	Lockup Reset Disable Set this bit to disable the LOCKUP signal(from the Cortex-M3) from resetting the device.

9.5.2 RMU_RSTCAUSE - Reset Cause Register

Offset	Bit Position																															
0x004	31	30	29	28	27	26	25	24	23	22	21	20	19	18	17	16	15	14	13	12	11	10	9	8	7	6	5	4	3	2	1	0
Reset																																0
Access																																R
Name																																SYSREQRST LOCKUPRST WDOGRST EXTRST BODREGRST BODUNREGRST PORST

Bit	Name	Reset	Access	Description
31:7	Reserved	To ensure compatibility with future devices, always write bits to 0. More information in Section 2.1 (p. 3)		
6	SYSREQRST	0	R	System Request Reset Set if a system request reset has been performed. Must be cleared by software. Please see Table 9.1 (p. 78) for details on how to interpret this bit.
5	LOCKUPRST	0	R	LOCKUP Reset Set if a LOCKUP reset has been requested. Must be cleared by software. Please see Table 9.1 (p. 78) for details on how to interpret this bit.
4	WDOGRST	0	R	Watchdog Reset Set if a watchdog reset has been performed. Must be cleared by software. Please see Table 9.1 (p. 78) for details on how to interpret this bit.

Bit	Name	Reset	Access	Description
3	EXTRST	0	R	External Pin Reset Set if an external pin reset has been performed. Must be cleared by software. Please see Table 9.1 (p. 78) for details on how to interpret this bit.
2	BODREGRST	0	R	Brown Out Detector Regulated Domain Reset Set if a regulated domain brown out detector reset has been performed. Must be cleared by software. Please see Table 9.1 (p. 78) for details on how to interpret this bit.
1	BODUNREGRST	0	R	Brown Out Detector Unregulated Domain Reset Set if an unregulated domain brown out detector reset has been performed. Must be cleared by software. Please see Table 9.1 (p. 78) for details on how to interpret this bit.
0	PORST	0	R	Power On Reset Set if a power on reset has been performed. Must be cleared by software. Please see Table 9.1 (p. 78) for details on how to interpret this bit.

9.5.3 RMU_CMD - Command Register

Offset	Bit Position																															
0x008	31	30	29	28	27	26	25	24	23	22	21	20	19	18	17	16	15	14	13	12	11	10	9	8	7	6	5	4	3	2	1	0
Reset																																0
Access																																W1
Name																																RCCLR

Bit	Name	Reset	Access	Description
31:1	<i>Reserved</i>	<i>To ensure compatibility with future devices, always write bits to 0. More information in Section 2.1 (p. 3)</i>		
0	RCCLR	0	W1	Reset Cause Clear Set this bit to clear the LOCKUPRST and SYSREQRST bits in the RMU_RSTCAUSE register. Use the HRCCLR bit in the EMU_AUXCTRL register to clear the remaining bits.

10 EMU - Energy Management Unit

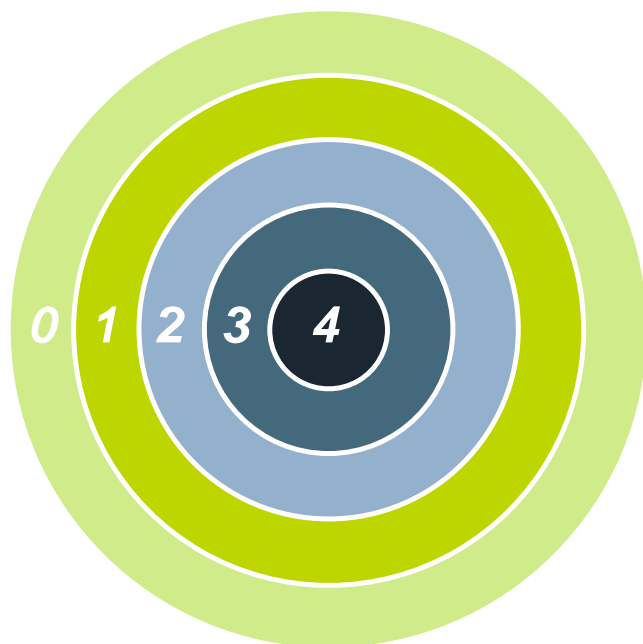

Quick Facts

What?

The EMU (Energy Management Unit) handles the different low energy modes in the EFM32G microcontrollers.

Why?

The need for performance and peripheral functions varies over time in most applications. By efficiently scaling the available resources in real-time to match the demands of the application, the energy consumption can be kept at a minimum.

How?

With a broad selection of energy modes, a high number of low-energy peripherals available even in EM2, and short wake-up time (2 μ s from EM2 and EM3), applications can dynamically minimize energy consumption during program execution.

10.1 Introduction

The Energy Management Unit (EMU) manages all the low energy modes (EM) in EFM32G microcontrollers. Each energy mode manages if the CPU and the various peripherals are available. The energy modes range from EM0 to EM4, where EM0, also called run mode, enables the CPU and all peripherals. The lowest recoverable energy mode, EM3, disables the CPU and most peripherals while maintaining wake-up and RAM functionality. EM4 disables everything except the POR and pin reset.

The various energy modes differ in:

- Energy consumption
- CPU activity
- Reaction time
- Wake-up triggers
- Active peripherals
- Available clock sources

Low energy modes EM1 to EM4 are enabled through the application software. In EM1-EM3, a range of wake-up triggers return the microcontroller back to EM0. EM4 can only return to EM0 by power on reset or external pin reset.

The EMU can also be used to turn off the power to unused SRAM blocks.

10.2 Features

- Energy Mode control from software
- Flexible wakeup from low energy modes
- Low wakeup time

10.3 Functional Description

The Energy Management Unit (EMU) is responsible for managing the wide range of energy modes available in EFM32G. An overview of the EMU module is shown in Figure 10.1 (p. 84) .

Figure 10.1. EMU Overview

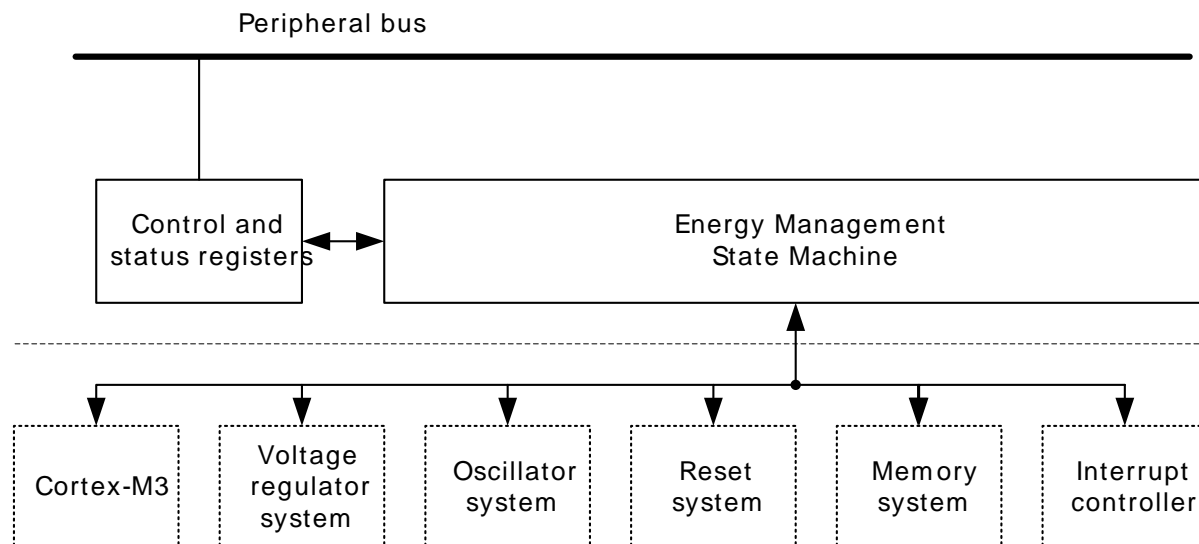

The EMU is available as a peripheral on the peripheral bus. The energy management state machine is triggered from the Cortex-M3 and controls the internal voltage regulators, oscillators, memories and interrupt systems in the low energy modes. Events from the interrupt or reset systems can in turn cause the energy management state machine to return to its active state. This is further described in the following sections.

10.3.1 Energy Modes

There are five main energy modes available in EFM32G, called Energy Mode 0 (EM0) through Energy Mode 4 (EM4). EM0, also called the active mode, is the energy mode in which any peripheral function can be enabled and the Cortex-M3 core is executing instructions. EM1 through EM4, also called low energy modes, provide a selection of reduced peripheral functionality that also lead to reduced energy consumption, as described below.

Figure 10.2 (p. 85) shows the transitions between different energy modes. After reset the EMU will always start in EM0. A transition from EM0 to another energy mode is always initiated by software. EM0 is the highest activity mode, in which all functionality is available. EM0 is therefore also the mode with highest energy consumption.

The low energy modes EM1 through EM4 result in less functionality being available, and therefore also reduced energy consumption. The Cortex-M3 is not executing instructions in any low energy mode. Each low energy mode provides different energy consumptions associated with it, for example because a different set of peripherals are enabled or because these peripherals are configured differently.

A transition from EM0 to a low energy mode can only be triggered by software.

A transition from EM1 – EM3 to EM0 can be triggered by an enabled interrupt or event. In addition, a chip reset will return the device to EM0. A transition from EM4 can only be triggered by a pin reset or power-on reset.

Figure 10.2. EMU Energy Mode Transitions

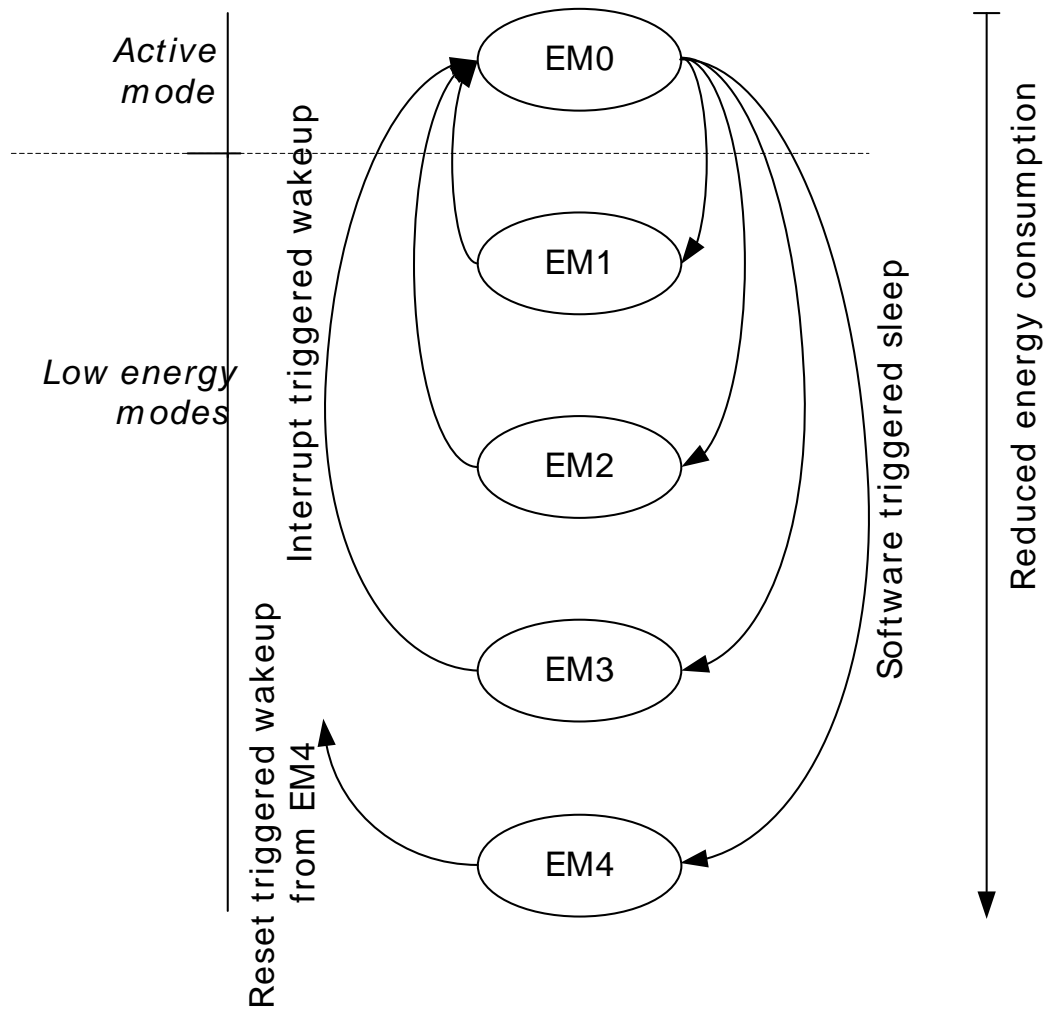

No direct transitions between EM1, EM2 or EM3 are available, as can also be seen from Figure 10.2 (p. 85) . Instead, a wakeup will transition back to EM0, in which software can enter any other low energy mode. An overview of the supported energy modes and the functionality available in each mode is shown in Table 10.1 (p. 86) . Most peripheral functionality indicated as On in a particular energy mode can also be turned off from software in order to save further energy.

Table 10.1. EMU Energy Mode Overview

	EM0 ¹	EM1 ²	EM2 ²	EM3 ²	EM4 ²
Wakeup time to EM0	-	-	2 μs	2 μs	160 μs
MCU clock tree	On	-	-	-	-
High frequency peripheral clock trees	On	On	-	-	-
Core voltage regulator	On	On	-	-	-
High frequency oscillator	On	On	-	-	-
I ² C full functionality	On	On	-	-	-
Low frequency peripheral clock trees	On	On	On	-	-
Low frequency oscillator	On	On	On	-	-
Real Time Counter	On	On	On	-	-
LCD	On	On	On	-	-
LEUART	On	On	On	-	-
LETIMER	On	On	On	-	-
PCNT	On	On	On	-	-
ACMP	On	On	On	On	-
I ² C receive address recognition	On	On	On	On	-
Watchdog	On	On	On	On ³	-
Pin interrupts	On	On	On	On	-
RAM voltage regulator/RAM retention	On	On	On	On	-
Brown Out Reset	On	On	On	On	-
Power On Reset	On	On	On	On	On
Pin Reset	On	On	On	On	On

¹Energy Mode 0/Active Mode²Energy Mode 1/2/3/4³When the 1 kHz clock is selected

The different Energy Modes are summarized in the following sections.

10.3.1.1 EM0

- The high frequency oscillator is active
- High frequency clock trees are active
- All peripheral functionality is available

10.3.1.2 EM1

- The high frequency oscillator is active
- MCU clock tree is inactive
- High frequency peripheral clock trees are active
- All peripheral functionality is available

10.3.1.3 EM2

- The high frequency oscillator is inactive
- The high frequency peripheral and MCU clock trees are inactive

- The low frequency oscillator and clock trees are active
- Low frequency peripheral functionality (RTC, Watchdog, LCD, LEUART, I²C, LETIMER, PCNT) is available
- Wakeup through peripheral interrupt or asynchronous pin interrupt
- RAM and register values are preserved

10.3.1.4 EM3

- Both high and low frequency oscillators and clock trees are inactive
- Wakeup through asynchronous pin interrupts, I²C address recognition or ACMP edge interrupt
- Watchdog enabled when 1 kHz clock has been selected
- All other peripheral functionality is disabled
- RAM and register values are preserved

10.3.1.5 EM4

- All oscillators and regulators are inactive
- RAM and register values are not preserved
- Wakeup from external pin reset

10.3.2 Entering a Low Energy Mode

A low energy mode is entered by first configuring the desired Energy Mode through the EMU_CTRL register and the SLEEPDEEP bit in the Cortex-M3 System Control Register, see Table 10.2 (p. 87). A Wait For Interrupt (WFI) or Wait For Event (WFE) instruction from the Cortex-M3 triggers the transition into a low energy mode.

The transition into a low energy mode can optionally be delayed until the lowest priority Interrupt Service Routine (ISR) is exited, if the SLEEPONEXIT bit in the Cortex-M3 System Control Register is set.

Entering the lowest energy mode, EM4, is done by writing a sequence to the EM4CTRL bitfield in the EMU_CTRL register. Writing a zero to the EM4CTRL bitfield will restart the power sequence. EM2BLOCK prevents the EMU to enter EM2 or lower, and it will instead enter EM1.

EM3 is equal to EM2, except that the LFACTK/LFBCLK are disabled in EM3. The LFACTK/LFBCLK must be disabled by the user before entering low energy mode.

The EMVREG bit in EMU_CTRL can be used to prevent the voltage regulator from being turned off in low energy modes. The device will then essentially stay in EM1 when entering a low energy mode.

Table 10.2. EMU Entering a Low Energy Mode

Low Energy Mode	EM4CTRL	EMVREG	EM2BLOCK	SLEEPDEEP	Cortex-M3 Instruction
EM1	0	x	x	0	WFI or WFE
EM2	0	0	0	1	WFI or WFE
EM4	Write sequence: 2, 3, 2, 3, 2, 3, 2, 3, 2	x	x	x	x

('x' means don't care)

10.3.3 Leaving a Low Energy Mode

In each low energy mode a selection of peripheral units are available, and software can either enable or disable the functionality. Enabled interrupts that can cause wakeup from a low energy mode is shown

in Table 10.3 (p. 88). The wakeup triggers always return the EFM32 to EM0. Additionally, any reset source will return to EM0.

Table 10.3. EMU Wakeup Triggers from Low Energy Modes

Peripheral	Wakeup Trigger	EM0 ¹	EM1 ²	EM2 ²	EM3 ²	EM4 ²
RTC	Any enabled interrupt	-	Yes	Yes	-	-
USART	Receive / transmit	-	Yes	-	-	-
UART	Receive / transmit	-	Yes	-	-	-
LEUART	Receive / transmit	-	Yes	Yes	-	-
I ² C	Any enabled interrupt	-	Yes	-	-	-
I ² C	Receive address recognition	-	Yes	Yes	Yes	-
TIMER	Any enabled interrupt	-	Yes	-	-	-
LETIMER	Any enabled interrupt	-	Yes	Yes	-	-
CMU	Any enabled interrupt	-	Yes	-	-	-
DMA	Any enabled interrupt	-	Yes	-	-	-
MSC	Any enabled interrupt	-	Yes	-	-	-
DAC	Any enabled interrupt	-	Yes	-	-	-
ADC	Any enabled interrupt	-	Yes	-	-	-
AES	Any enabled interrupt	-	Yes	-	-	-
PCNT	Any enabled interrupt	-	Yes	Yes	Yes ³	-
LCD	Any enabled interrupt	-	Yes	Yes	-	-
ACMP	Any enabled edge interrupt	-	Yes	Yes	Yes	-
VCMP	Any enabled edge interrupt	-	Yes	Yes	Yes	-
Pin interrupts	Asynchronous	-	Yes	Yes	Yes	-
Pin	Reset	-	Yes	Yes	Yes	Yes
Power	Cycle Off/On		Yes	Yes	Yes	Yes

¹Energy Mode 0/Active Mode

²Energy mode 1/2/3/4

³When using an external clock

10.3.4 Powering off SRAM blocks

The SRAM blocks can be individually disabled using the POWERDOWN bitfield in the EMU_MEMCTRL register. To disable a block means that the power source is removed from the entire block, which will conserve energy. Once a block has been disabled it can only be enabled by reset.

All the blocks can be turned off except the first one.

10.4 Register Map

The offset register address is relative to the registers base address.

Offset	Name	Type	Description
0x000	EMU_CTRL	RW	Control Register
0x004	EMU_MEMCTRL	RW	Memory Control Register
0x008	EMU_LOCK	RW	Configuration Lock Register
0x024	EMU_AUXCTRL	RW	Auxiliary Control Register

10.5 Register Description

10.5.1 EMU_CTRL - Control Register

Offset	Bit Position																															
	31	30	29	28	27	26	25	24	23	22	21	20	19	18	17	16	15	14	13	12	11	10	9	8	7	6	5	4	3	2	1	0
0x000																											EM4CTRL	EM2BLOCK	EMVREG			
Reset																											0x0	0	0			
Access																											RW	RW	RW			
Name																											EM4CTRL	EM2BLOCK	EMVREG			

Bit	Name	Reset	Access	Description									
31:4	Reserved	To ensure compatibility with future devices, always write bits to 0. More information in Section 2.1 (p. 3)											
3:2	EM4CTRL	0x0	RW	Energy Mode 4 Control This register is used to enter Energy Mode 4, in which the device only wakes up from an external pin reset, from a power cycle, or EM4 wakeup reset request. Energy Mode 4 is entered when the EM4 sequence is written to this bitfield.									
1	EM2BLOCK	0	RW	Energy Mode 2 Block This bit is used to prevent the MCU to enter Energy Mode 2 or lower.									
0	EMVREG	0	RW	Energy Mode Voltage Regulator Control Control the voltage regulator in low energy modes 2 and 3.									
<table border="1"> <thead> <tr> <th>Value</th> <th>Mode</th> <th>Description</th> </tr> </thead> <tbody> <tr> <td>0</td> <td>REDUCED</td> <td>Reduced voltage regulator drive strength in EM2 and EM3.</td> </tr> <tr> <td>1</td> <td>FULL</td> <td>Full voltage regulator drive strength in EM2 and EM3.</td> </tr> </tbody> </table>					Value	Mode	Description	0	REDUCED	Reduced voltage regulator drive strength in EM2 and EM3.	1	FULL	Full voltage regulator drive strength in EM2 and EM3.
Value	Mode	Description											
0	REDUCED	Reduced voltage regulator drive strength in EM2 and EM3.											
1	FULL	Full voltage regulator drive strength in EM2 and EM3.											

10.5.2 EMU_MEMCTRL - Memory Control Register

Offset	Bit Position																															
	31	30	29	28	27	26	25	24	23	22	21	20	19	18	17	16	15	14	13	12	11	10	9	8	7	6	5	4	3	2	1	0
0x004																											POWERDOWN					
Reset																											0x0					
Access																											RW					
Name																											POWERDOWN					

Bit	Name	Reset	Access	Description
31:3	Reserved	To ensure compatibility with future devices, always write bits to 0. More information in Section 2.1 (p. 3)		

Bit	Name	Reset	Access	Description
2:0	POWERDOWN	0x0	RW	RAM block power-down
Individual 4KB RAM block power-down. When a block is powered down, it cannot be powered up again. The block will be powered up after the reset. Block 0 (address range 0x20000000-0x20000FFF) may never be powered down.				
	Value	Mode	Description	
	4	BLK3	Power down RAM block 3 (address range 0x20003000-0x20003FFF)	
	6	BLK23	Power down RAM blocks 2-3 (address range 0x20002000-0x20003FFF)	
	7	BLK123	Power down RAM blocks 1-3 (address range 0x20001000-0x20003FFF)	

10.5.3 EMU_LOCK - Configuration Lock Register

Offset	Bit Position																															
0x008	31	30	29	28	27	26	25	24	23	22	21	20	19	18	17	16	15	14	13	12	11	10	9	8	7	6	5	4	3	2	1	0
Reset																	0x0000															
Access																	RW															
Name																	LOCKKEY															

Bit	Name	Reset	Access	Description
31:16	Reserved	To ensure compatibility with future devices, always write bits to 0. More information in Section 2.1 (p. 3)		
15:0	LOCKKEY	0x0000	RW	Configuration Lock Key
Write any other value than the unlock code to lock all EMU registers from editing. Write the unlock code to unlock. When reading the register, bit 0 is set when the lock is enabled.				
	Mode	Value	Description	
	Read Operation			
	UNLOCKED	0	EMU registers are unlocked	
	LOCKED	1	EMU registers are locked	
	Write Operation			
	LOCK	0	Lock EMU registers	
	UNLOCK	0xADE8	Unlock EMU registers	

10.5.4 EMU_AUXCTRL - Auxiliary Control Register

Offset	Bit Position																															
0x024	31	30	29	28	27	26	25	24	23	22	21	20	19	18	17	16	15	14	13	12	11	10	9	8	7	6	5	4	3	2	1	0
Reset																																0
Access																																RW
Name																																HRCCLR

Bit	Name	Reset	Access	Description
31:1	Reserved	To ensure compatibility with future devices, always write bits to 0. More information in Section 2.1 (p. 3)		
0	HRCCLR	0	RW	Hard Reset Cause Clear

Bit	Name	Reset	Access	Description
Write to 1 and then 0 to clear the POR, BOD and WDOG reset cause register bits. See also the Reset Management Unit (RMU).				

11 CMU - Clock Management Unit

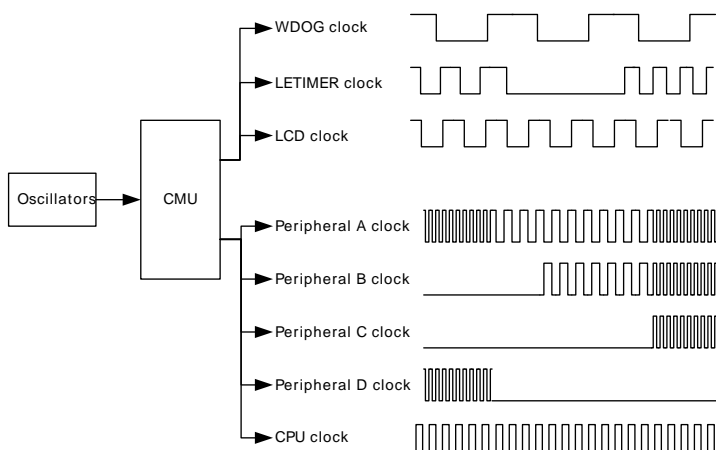
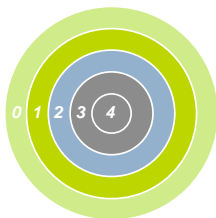

Quick Facts

What?

The CMU controls oscillators and clocks. EFM32G supports four different oscillators with minimized power consumption and short start-up time. An additional separate RC oscillator is used for flash programming and debug trace. The CMU also has HW support for calibration of RC oscillators.

Why?

Oscillators and clocks contribute significantly to the power consumption of the MCU. With the low power oscillators combined with the flexible clock control scheme, it is possible to minimize the energy consumption in any given application.

How?

The CMU can configure different clock sources, enable/disable clocks to peripherals on an individual basis and set the prescaler for the different clocks. The short oscillator start-up times makes duty-cycling between active mode and the different low energy modes (EM2-4) very efficient. The calibration feature ensures high accuracy RC oscillators. Several interrupts are available to avoid CPU polling of flags.

11.1 Introduction

The Clock Management Unit (CMU) is responsible for controlling the oscillators and clocks on-board the EFM32G. The CMU provides the capability to turn on and off the clock on an individual basis to all peripheral modules in addition to enable/disable and configure the available oscillators. The high degree of flexibility enables software to minimize energy consumption in any specific application by not wasting power on peripherals and oscillators that are inactive.

11.2 Features

- Multiple clock sources available:
 - 1-28 MHz High Frequency RC Oscillator (HFRCO)
 - 4-32 MHz High Frequency Crystal Oscillator (HF XO)
 - 32.768 kHz Low Frequency RC Oscillator (LFRCO)
 - 32.768 kHz Low Frequency Crystal Oscillator (LF XO)
- Low power oscillators
- Low start-up times
- Separate prescaler for High Frequency Core Clocks (HFCORECLK) and Peripheral Clocks (HFPERCLK)
- Individual clock prescaler selection for each Low Energy Peripheral
- Clock Gating on an individual basis to core modules and all peripherals

- Selectable clocks can be output on two pins for use externally.
- Auxiliary 14 MHz RC oscillator (AUXHFRCO) for flash programming and debug trace.

11.3 Functional Description

An overview of the CMU is shown in Figure 11.1 (p. 94). The number of peripheral modules that are connected to the different clocks varies from device to device.

Figure 11.1. CMU Overview

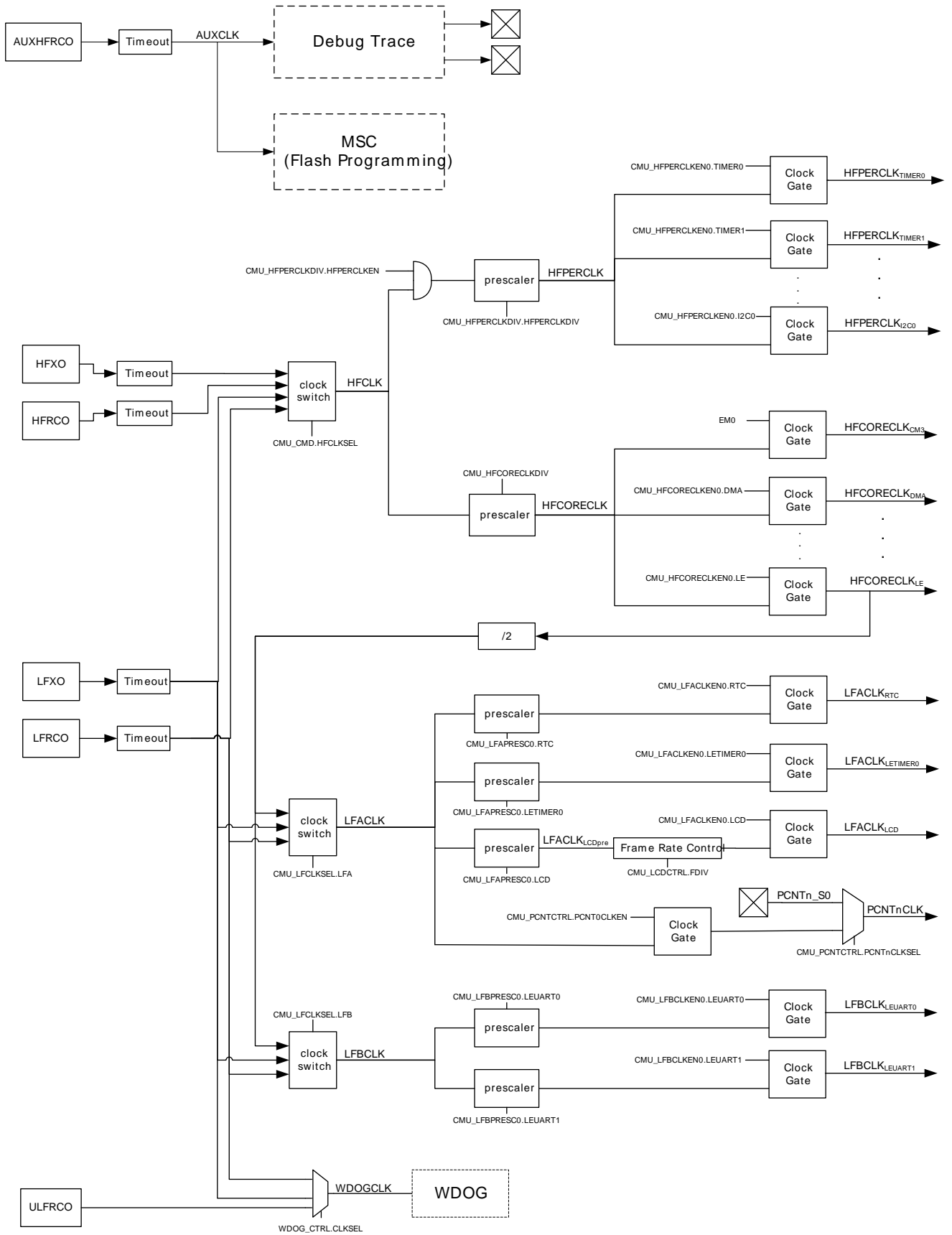

11.3.1 System Clocks

11.3.1.1 HFCLK - High Frequency Clock

HFCLK is the selected High Frequency Clock. This clock is used by the CMU and drives the two prescalers that generate HFCORECLK and HFPERCLK. The HFCLK can be driven by a high-frequency oscillator (HFRCO or HFXO) or one of the low-frequency oscillators (LFRCO or LFXO). By default the HFRCO is selected. In most applications, one of the high frequency oscillators will be the preferred choice. To change the selected HFCLK write to HFCLKSEL in CMU_CMD. The HFCLK is running in EM0 and EM1.

11.3.1.2 HFCORECLK - High Frequency Core Clock

HFCORECLK is a prescaled version of HFCLK. This clock drives the Core Modules, which consists of the CPU and modules that are tightly coupled to the CPU, e.g. MSC, DMA etc. This also includes the interface to the Low Energy Peripherals. Some of the modules that are driven by this clock can be clock gated completely when not in use. This is done by clearing the clock enable bit for the specific module in CMU_HFCORECLKEN0. The frequency of HFCORECLK is set using the CMU_HFCORECLKDIV register. The setting can be changed dynamically and the new setting takes effect immediately.

Note

Note that if HFPERCLK runs faster than HFCORECLK, the number of clock cycles for each bus-access to peripheral modules will increase with the ratio between the clocks. Please refer to Section 5.2.3.2 (p. 18) for more details.

11.3.1.3 HFPERCLK - High Frequency Peripheral Clock

Like HFCORECLK, HFPERCLK is also a potentially prescaled version of HFCLK. This clock drives the High-Frequency Peripherals. All the peripherals that are driven by this clock can be clock gated completely when not in use. This is done by clearing the clock enable bit for the specific peripheral in CMU_HFPERCLKEN0. The frequency of HFPERCLK is set using the CMU_HFPERCLKDIV register. The setting can be changed dynamically and the new setting takes effect immediately.

Note

Note that if HFPERCLK runs faster than HFCORECLK, the number of clock cycles for each bus-access to peripheral modules will increase with the ratio between the clocks. E.g. if a bus-access normally takes three cycles, it will take 9 cycles if HFPERCLK runs three times as fast as the HFCORECLK.

11.3.1.4 LFACTK - Low Frequency A Clock

LFACTK is the selected clock for the Low Energy A Peripherals. There are three selectable sources for LFACTK: LFRCO, LFXO and HFCORECLK_{LE}/2. In addition, the LFACTK can be disabled. From reset, the LFACTK source is set to LFRCO. However, note that the LFRCO is disabled from reset. The selection is configured using the LFA field in CMU_LFCLKSEL. The HFCORECLK_{LE}/2 setting allows the Low Energy A Peripherals to be used as high-frequency peripherals.

Note

If HFCORECLK/2 is selected as LFACTK, the clock will stop in EM2/3.

Each Low Energy Peripheral that is clocked by LFACTK has its own prescaler setting and enable bit. The prescaler settings are configured using CMU_LFAPRESC0 and the clock enable bits can be found in CMU_LFACTKEN0. Notice that the LCD has an additional high resolution prescaler for Frame Rate Control, configured by FDIV in CMU_LCDCTRL. When operating in oversampling mode, the pulse counters are clocked by LFACTK. This is configured for each pulse counter (n) individually by setting PCNTnCLKSEL in CMU_PCNTCTRL.

11.3.1.5 LFBCLK - Low Frequency B Clock

LFBCLK is the selected clock for the Low Energy B Peripherals. There are three selectable sources for LFBCLK: LFRCO, LFXO and HFCORECLK_{LE}/2. In addition, the LFBCLK can be disabled. From reset, the LFBCLK source is set to LFRCO. However, note that the LFRCO is disabled from reset. The selection is configured using the LFB field in CMU_LFCLKSEL. The HFCORECLK_{LE}/2 setting allows the Low Energy B Peripherals to be used as high-frequency peripherals.

Note

If HFCORECLK/2 is selected as LFBCLK, the clock will stop in EM2/3.

Each Low Energy Peripheral that is clocked by LFBCLK has its own prescaler setting and enable bit. The prescaler settings are configured using CMU_LFBPRESC0 and the clock enable bits can be found in CMU_LFBCLKEN0.

11.3.1.6 PCNTnCLK - Pulse Counter n Clock

Each available pulse counter is driven by its own clock, PCNTnCLK where n is the pulse counter instance number. Each pulse counter can be configured to use an external pin (PCNTn_S0) or LFACTK as PCNTnCLK.

11.3.1.7 WDOGCLK - Watchdog Timer Clock

The Watchdog Timer (WDOG) can be configured to use one of three different clock sources: LFRCO, LFXO or ULFRCO. ULFRCO (Ultra Low Frequency RC Oscillator) is a separate 1 kHz RC oscillator that also runs in EM3.

11.3.1.8 AUXCLK - Auxiliary Clock

AUXCLK is a 14 MHz clock driven by a separate RC oscillator, AUXHFRCO. This clock is used for flash programming and Serial Wire Output (SWO). During flash programming, this clock will be active. If the AUXHFRCO has not been enabled explicitly by software, the MSC module will automatically start and stop it. The AUXHFRCO is enabled by writing a 1 to AUXHFRCOEN in CMU_OSCENCMD. This explicit enabling is required when SWO is used.

11.3.2 Oscillator Selection

11.3.2.1 Start-up Time

The different oscillators have different start-up times. For the RC oscillators, the start-up time is fixed, but both the LFXO and the HFXO have configurable start-up time. The start-up time is configured by software and can be optimized for the chosen crystal used in the application.

There are individual bits for each oscillator indicating the status of the oscillator:

- ENABLED - Indicates that the oscillator is enabled
- READY - Start-up time is exceeded
- SELECTED - Start-up time is exceeded and oscillator is chosen as clock source

These status bits are located in the CMU_STATUS register.

11.3.2.2 Switching Clock Source

The HFRCO oscillator is a low energy oscillator with extremely short wake-up time. Therefore, this oscillator is always chosen by hardware as the clock source for HFCLK when the device starts up (e.g. after reset and after waking up from EM2 and EM3). After reset, the HFRCO frequency is 14 MHz.

Software can switch between the different clock sources at run-time. E.g., when the HFRCO is the clock source, software can switch to HFXO by writing the field HFCLKSEL in the CMU_CMD command register. See Figure 11.2 (p. 97) for a description of the sequence of events for this specific operation.

Note

It is important first to enable the HFXO since switching to a disabled oscillator will effectively stop HFCLK and only a reset can recover the system.

During the start-up period HFCLK will stop since the oscillator driving it is not ready. This effectively stalls the Core Modules and the High-Frequency Peripherals. It is possible to avoid this by first enabling the HFXO and then wait for the oscillator to become ready before switching the clock source. This way, the system continues to run on the HFRCO until the HFXO has timed out and provides a reliable clock. This sequence of events is shown in Figure 11.3 (p. 98) .

A separate flag is set when the oscillator is ready. This flag can also be configured to generate an interrupt.

Figure 11.2. CMU Switching from HFRCO to HFXO before HFXO is ready

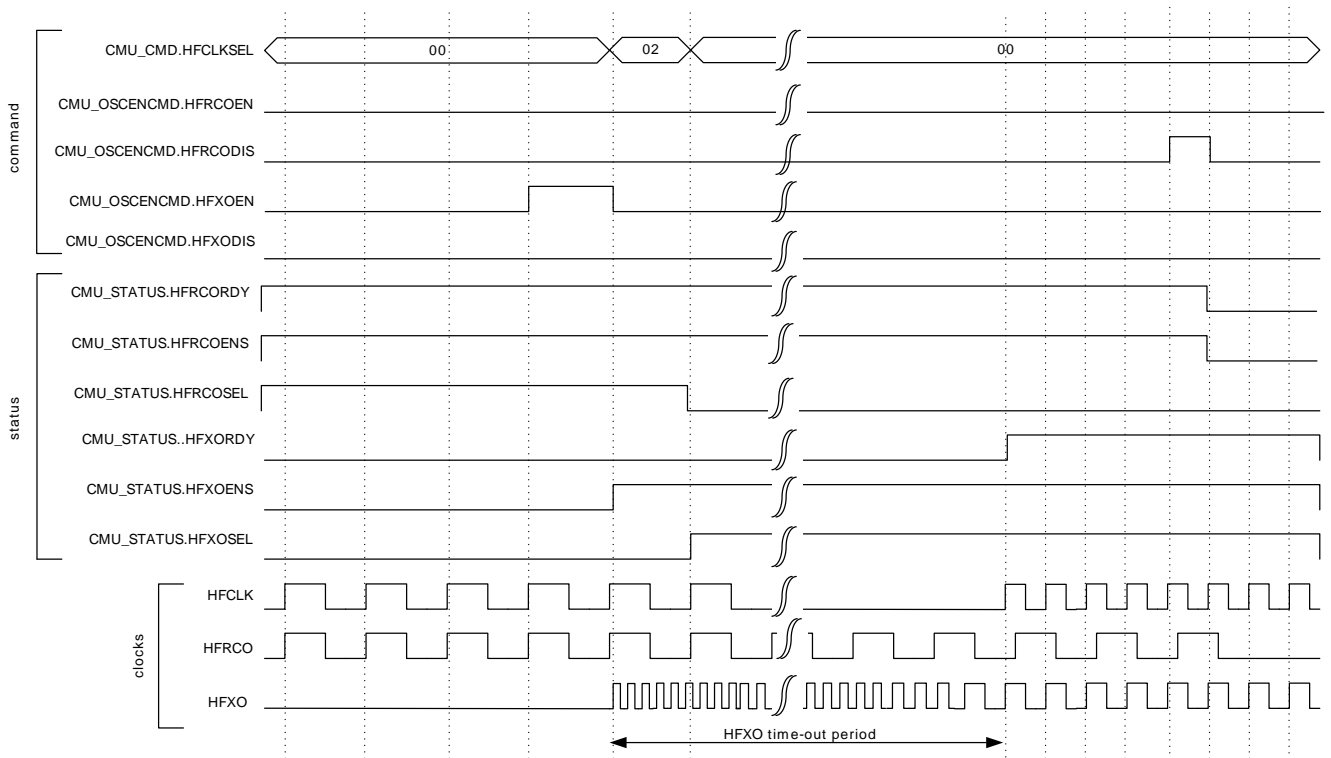
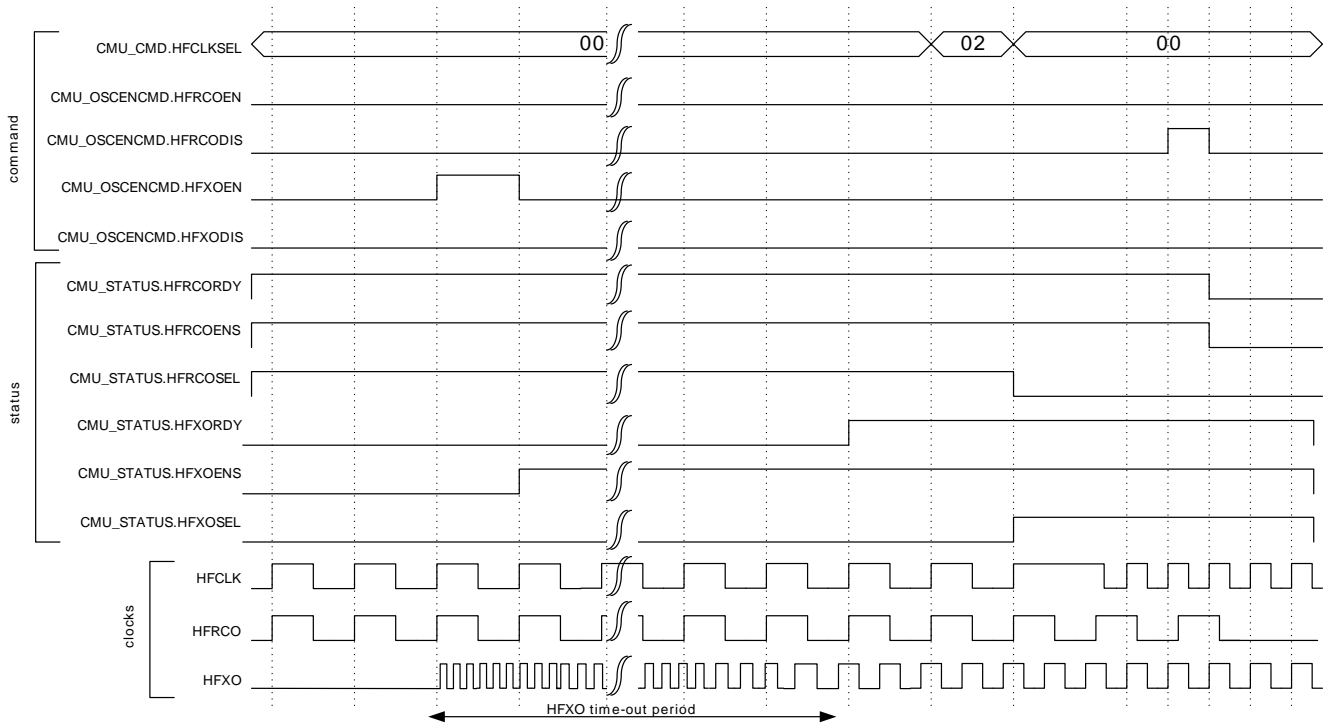

Figure 11.3. CMU Switching from HFRCO to HFXO after HFXO is ready



Switching clock source for LFACLK and LFBCLK is done by setting the LFA and LFB fields in CMU_LFCLKSEL. To ensure no stalls in the Low Energy Peripherals, the clock source should be ready before switching to it.

Note

To save energy, remember to turn off all oscillators not in use.

11.3.3 Oscillator Configuration

11.3.3.1 HFXO and LFXO

The crystal oscillators are by default configured to ensure safe startup of all crystals. In order to optimize startup time and power consumption for a given crystal, it is possible to adjust the gain in the oscillator by programming the LFXOBOOST and HFXOBOOST fields in CMU_CTRL for LFXO and HFXO respectively.

The HFXO crystal is connected to the HFXTAL_N/HFXTAL_P pins as shown in Figure 11.4 (p. 98)

Figure 11.4. HFXO Pin Connection

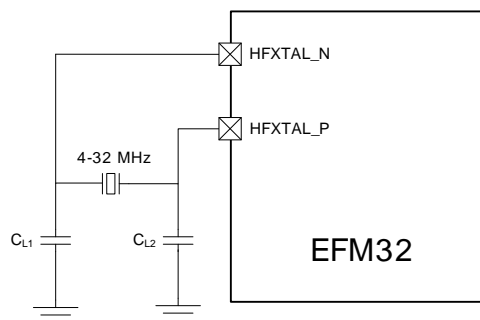

Similarly, the LFXO crystal is connected to the LFXXTAL_N/LFXXTAL_P pins as shown in Figure 11.5 (p. 99)

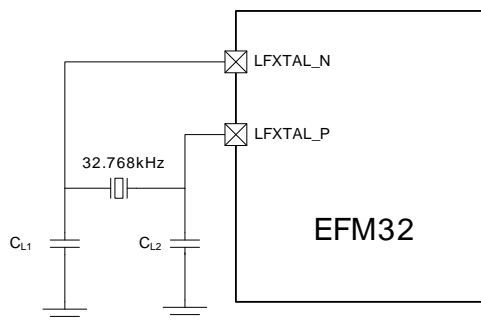
Figure 11.5. LFXO Pin Connection

It is possible to connect an external clock source to HFXTAL_N/LFXTAL_N pin of the HFXO or LFXO oscillator. By configuring the HFXOMODE/LFXOMODE fields in CMU_CTRL, the HFXO/LFXO can be bypassed.

11.3.3.2 HFRCO, LFRCO and AUXHFRCO

It is possible to calibrate the HFRCO, LFRCO and AUXHFRCO to achieve higher accuracy (see the device datasheets for details on accuracy). The frequency is adjusted by changing the TUNING fields in CMU_HFRCOCTRL/CMU_LFRCOCTRL/CMU_AUXHFRCOCTRL. Changing to a higher value will result in a higher frequency. Please refer to the datasheet for stepsize details.

The HFRCO can be set to one of several different frequency bands from 1 MHz to 28 MHz by setting the BAND field in CMU_HFRCOCTRL. The HFRCO frequency bands are calibrated during production test, and the production tested calibration values can be read from the Device Information (DI) page. The DI page contains a separate tuning value for each frequency band. During reset HFRCO tuning value is set to the production calibrated value for the 14 MHz band, which is the default frequency band. When changing to a different HFRCO band, make sure to also update the tuning value.

The LFRCO and AUXHFRCO are also calibrated in production and their TUNING value is set to the correct value during reset.

The CMU has built-in HW support to efficiently calibrate the RC oscillators at run-time, see Figure 11.6 (p. 100). The concept is to select a reference and compare the RC frequency with the reference frequency. When the calibration circuit is started, one down-counter running on HFCLK and one up-counter running on a selectable reference clock are started simultaneously. When the down-counter has reached 0, both counters are stopped and software can read out the reference counter value (CALCLK counter) and compare with the start value of the down-counter. Then it is easy to find the ratio between the reference and the oscillator subject to the calibration. With this HW support, it is simple to write efficient calibration algorithms in software.

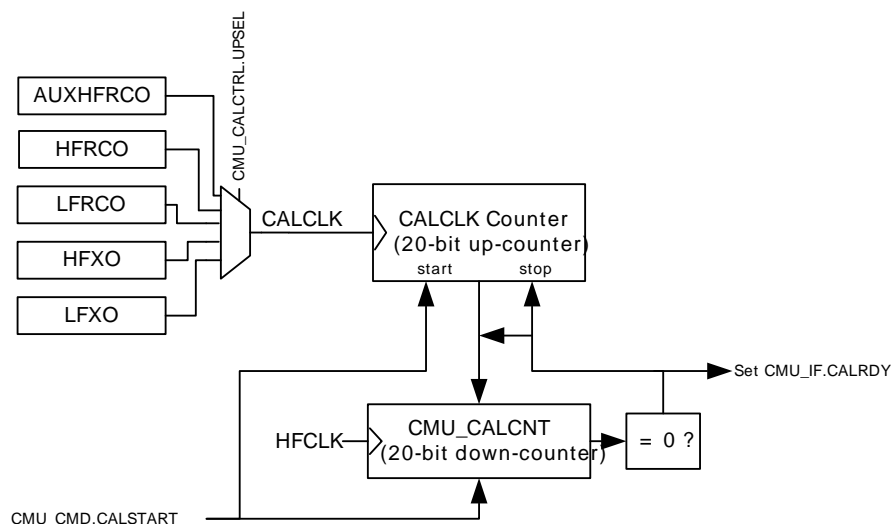
Figure 11.6. HW-support for RC Oscillator Calibration

11.3.4 Output Clock on a Pin

It is possible to configure the CMU to output clocks on two pins. This clock selection is done using CLKOUTSEL0 and CLKOUTSEL1 fields in CMU_CTRL. The output pins must be configured in the CMU_ROUTE register.

- LFRCO or LFXO can be output on one pin (CMU_OUT1)
- HFRCO, HFXO, HFCLK/2, HFCLK/4, HFCLK/8, HFCLK/16 or ULFRCO can be output on another pin (CMU_OUT0)

Note that HFXO and HFRCO clock outputs to pin can be unstable after startup and should not be output on a pin before HFXORDY/HFRCORDY is set high in CMU_STATUS.

11.3.5 Protection

It is possible to lock the control- and command registers to prevent unintended software writes to critical clock settings. This is controlled by the CMU_LOCK register.

11.4 Register Map

The offset register address is relative to the registers base address.

Offset	Name	Type	Description
0x000	CMU_CTRL	RW	CMU Control Register
0x004	CMU_HFCORECLKDIV	RW	High Frequency Core Clock Division Register
0x008	CMU_HFPERCLKDIV	RW	High Frequency Peripheral Clock Division Register
0x00C	CMU_HFRCTRL	RW	HFRCO Control Register
0x010	CMU_LFRCTRL	RW	LFRCO Control Register
0x014	CMU_AUXHFRCTRL	RW	AUXHFRCO Control Register
0x018	CMU_CALCTRL	RW	Calibration Control Register
0x01C	CMU_CALCNT	RWH	Calibration Counter Register
0x020	CMU_OSCENCMD	W1	Oscillator Enable/Disable Command Register
0x024	CMU_CMD	W1	Command Register
0x028	CMU_LFCLKSEL	RW	Low Frequency Clock Select Register
0x02C	CMU_STATUS	R	Status Register
0x030	CMU_IF	R	Interrupt Flag Register
0x034	CMU_IFS	W1	Interrupt Flag Set Register
0x038	CMU_IFC	W1	Interrupt Flag Clear Register
0x03C	CMU_IEN	RW	Interrupt Enable Register
0x040	CMU_HFCORECLKEN0	RW	High Frequency Core Clock Enable Register 0
0x044	CMU_HFPERCLKEN0	RW	High Frequency Peripheral Clock Enable Register 0
0x050	CMU_SYNCBUSY	R	Synchronization Busy Register
0x054	CMU_FREEZE	RW	Freeze Register
0x058	CMU_LFACLKEN0	RW	Low Frequency A Clock Enable Register 0 (Async Reg)
0x060	CMU_LFBCLKEN0	RW	Low Frequency B Clock Enable Register 0 (Async Reg)
0x068	CMU_LFAPRESC0	RW	Low Frequency A Prescaler Register 0 (Async Reg)
0x070	CMU_LFBPRESC0	RW	Low Frequency B Prescaler Register 0 (Async Reg)
0x078	CMU_PCNTCTRL	RW	PCNT Control Register
0x07C	CMU_LCDCTRL	RW	LCD Control Register
0x080	CMU_ROUTE	RW	I/O Routing Register
0x084	CMU_LOCK	RW	Configuration Lock Register

11.5 Register Description

11.5.1 CMU_CTRL - CMU Control Register

Offset	Bit Position																																																
0x000	31	30	29	28	27	26	25	24	23	22	21	20	19	18	17	16	15	14	13	12	11	10	9	8	7	6	5	4	3	2	1	0																	
Reset									0	0x0				0x3				0					1	0x0				0x3				0	0x1				0x3				0x0								
Access									RW	RW				RW				RW	RW				RW	RW				RW				RW				RW													
Name									CLKOUTSEL1	CLKOUTSEL0				LFXOTIMEOUT				LFXOBUFCUR					LFXOBOOST	LFXOMODE				HFXTIMEOUT					HFXTGLITCHDETEN				HFXTBUFCUR					HFXTBOOST				HFXTMODE			

Bit	Name	Reset	Access	Description
31:24	Reserved	To ensure compatibility with future devices, always write bits to 0. More information in Section 2.1 (p. 3)		

23	CLKOUTSEL1	0	RW	Clock Output Select 1 Controls the clock output multiplexer. To actually output on the pin, set CLKOUT1PEN in CMU_ROUTE.
	Value	Mode	Description	
	0	LFRCO	LFRCO (directly from oscillator)	
	1	LFXO	LFXO (directly from oscillator)	

22:20	CLKOUTSEL0	0x0	RW	Clock Output Select 0 Controls the clock output multiplexer. To actually output on the pin, set CLKOUT0PEN in CMU_ROUTE.
	Value	Mode	Description	
	0	HFRCO	HFRCO (directly from oscillator)	
	1	HFXO	HFXO (directly from oscillator)	
	2	HFCLK2	HFCLK/2	
	3	HFCLK4	HFCLK/4	
	4	HFCLK8	HFCLK/8	
	5	HFCLK16	HFCLK/16	
	6	ULFRCO	ULFRCO (directly from oscillator)	

19:18	LFXOTIMEOUT	0x3	RW	LFXO Timeout Configures the start-up delay for LFXO.
	Value	Mode	Description	
	0	8CYCLES	Timeout period of 8 cycles	
	1	1KCYCLES	Timeout period of 1024 cycles	
	2	16KCYCLES	Timeout period of 16384 cycles	
	3	32KCYCLES	Timeout period of 32768 cycles	

17	LFXOBUFCUR	0	RW	LFXO Boost Buffer Current This value has been set during calibration and should not be changed.
----	------------	---	----	---

16:14	Reserved	To ensure compatibility with future devices, always write bits to 0. More information in Section 2.1 (p. 3)		
-------	----------	---	--	--

13	LFXOBOOST	1	RW	LFXO Start-up Boost Current Adjusts start-up boost current for LFXO.
	Value	Mode	Description	
	0	70PCENT	70 %	
	1	100PCENT	100 % (default)	

12:11	LFXOMODE	0x0	RW	LFXO Mode Set this to configure the external source for the LFXO. The oscillator setting takes effect when 1 is written to LFXOEN in CMU_OSCENCMD. The oscillator setting is reset to default when 1 is written to LFXODIS in CMU_OSCENCMD.
-------	----------	-----	----	---

Bit	Name	Reset	Access	Description
	Value	Mode		Description
	0	XTAL		32.768 kHz crystal oscillator
	1	BUFEXTCLK		An AC coupled buffer is coupled in series with LFXTAL_N pin, suitable for external sinus wave (32.768 kHz).
	2	DIGEXTCLK		Digital external clock on LFXTAL_N pin. Oscillator is effectively bypassed.
10:9	HFXOTIMEOUT	0x3	RW	HFXO Timeout Configures the start-up delay for HFXO.
	Value	Mode		Description
	0	8CYCLES		Timeout period of 8 cycles
	1	256CYCLES		Timeout period of 256 cycles
	2	1KCYCLES		Timeout period of 1024 cycles
	3	16KCYCLES		Timeout period of 16384 cycles
8	<i>Reserved</i>	<i>To ensure compatibility with future devices, always write bits to 0. More information in Section 2.1 (p. 3)</i>		
7	HFXOGLITCHDETEN	0	RW	HFXO Glitch Detector Enable This bit enables the glitch detector which is active as long as the start-up ripple-counter is counting. A detected glitch will reset the ripple-counter effectively increasing the start-up time. Once the ripple-counter has timed-out, glitches will not be detected.
6:5	HFXOBUF CUR	0x1	RW	HFXO Boost Buffer Current This value has been set during calibration and should not be changed.
4	<i>Reserved</i>	<i>To ensure compatibility with future devices, always write bits to 0. More information in Section 2.1 (p. 3)</i>		
3:2	HFXOBOOST	0x3	RW	HFXO Start-up Boost Current Used to adjust start-up boost current for HFXO.
	Value	Mode		Description
	0	50PCENT		50 %
	1	70PCENT		70 %
	2	80PCENT		80 %
	3	100PCENT		100 % (default)
1:0	HFXOMODE	0x0	RW	HFXO Mode Set this to configure the external source for the HFXO. The oscillator setting takes effect when 1 is written to HFXOEN in CMU_OSCENCMD. The oscillator setting is reset to default when 1 is written to HFXODIS in CMU_OSCENCMD.
	Value	Mode		Description
	0	XTAL		4-32 MHz crystal oscillator
	1	BUFEXTCLK		An AC coupled buffer is coupled in series with HFXTAL_N, suitable for external sine wave (4-32 MHz). The sine wave should have a minimum of 200mV peak to peak.
	2	DIGEXTCLK		Digital external clock on HFXTAL_N pin. Oscillator is effectively bypassed.

11.5.2 CMU_HFCORECLKDIV - High Frequency Core Clock Division Register

Offset	Bit Position																															
0x004	31	30	29	28	27	26	25	24	23	22	21	20	19	18	17	16	15	14	13	12	11	10	9	8	7	6	5	4	3	2	1	0
Reset																																
Access																																
Name	HFCORECLKDIV																															

Bit	Name	Reset	Access	Description
31:4	Reserved	To ensure compatibility with future devices, always write bits to 0. More information in Section 2.1 (p. 3)		
3:0	HFCORECLKDIV	0x0	RW	HFCORECLK Divider Specifies the clock divider for HFCORECLK.
	Value	Mode	Description	
	0	HFCLK	HFCORECLK = HFCLK	
	1	HFCLK2	HFCORECLK = HFCLK/2	
	2	HFCLK4	HFCORECLK = HFCLK/4	
	3	HFCLK8	HFCORECLK = HFCLK/8	
	4	HFCLK16	HFCORECLK = HFCLK/16	
	5	HFCLK32	HFCORECLK = HFCLK/32	
	6	HFCLK64	HFCORECLK = HFCLK/64	
	7	HFCLK128	HFCORECLK = HFCLK/128	
	8	HFCLK256	HFCORECLK = HFCLK/256	
	9	HFCLK512	HFCORECLK = HFCLK/512	

11.5.3 CMU_HFPERCLKDIV - High Frequency Peripheral Clock Division Register

Offset	Bit Position																															
0x008	31	30	29	28	27	26	25	24	23	22	21	20	19	18	17	16	15	14	13	12	11	10	9	8	7	6	5	4	3	2	1	0
Reset																								1					0x0			
Access																								RW					RW			
Name																								HFPERCLKEN					HFPERCLKDIV			

Bit	Name	Reset	Access	Description
31:9	Reserved	To ensure compatibility with future devices, always write bits to 0. More information in Section 2.1 (p. 3)		
8	HFPERCLKEN	1	RW	HFPERCLK Enable Set to enable the HFPERCLK.
7:4	Reserved	To ensure compatibility with future devices, always write bits to 0. More information in Section 2.1 (p. 3)		
3:0	HFPERCLKDIV	0x0	RW	HFPERCLK Divider Specifies the clock divider for the HFPERCLK.
	Value	Mode	Description	
	0	HFCLK	HFPERCLK = HFCLK	
	1	HFCLK2	HFPERCLK = HFCLK/2	
	2	HFCLK4	HFPERCLK = HFCLK/4	
	3	HFCLK8	HFPERCLK = HFCLK/8	
	4	HFCLK16	HFPERCLK = HFCLK/16	
	5	HFCLK32	HFPERCLK = HFCLK/32	
	6	HFCLK64	HFPERCLK = HFCLK/64	
	7	HFCLK128	HFPERCLK = HFCLK/128	
	8	HFCLK256	HFPERCLK = HFCLK/256	
	9	HFCLK512	HFPERCLK = HFCLK/512	

11.5.4 CMU_HFRCTRL - HFRCO Control Register

Offset	Bit Position																															
0x00C	31	30	29	28	27	26	25	24	23	22	21	20	19	18	17	16	15	14	13	12	11	10	9	8	7	6	5	4	3	2	1	0
Reset																	0x00			0x3			0x80									
Access																	RW			RW			RW									
Name																	SUDELAY			BAND			TUNING									

Bit	Name	Reset	Access	Description
31:17	Reserved	To ensure compatibility with future devices, always write bits to 0. More information in Section 2.1 (p. 3)		

16:12	SUDELAY	0x00	RW	HFRCO Start-up Delay Always write this field to 0.
-------	---------	------	----	--

11	Reserved	To ensure compatibility with future devices, always write bits to 0. More information in Section 2.1 (p. 3)		
----	----------	---	--	--

10:8	BAND	0x3	RW	HFRCO Band Select Write this field to set the frequency band in which the HFRCO is to operate. When changing this setting there will be no glitches on the HFRCO output, hence it is safe to change this setting even while the system is running on the HFRCO. To ensure an accurate frequency, the HFTUNING value should also be written when changing the frequency band. The calibrated tuning value for the different bands can be read from the Device Information page.
------	------	-----	----	--

Value	Mode	Description
0	1MHZ	1 MHz. NOTE: Also set the TUNING value (bits 7:0) when changing band.
1	7MHZ	7 MHz. NOTE: Also set the TUNING value (bits 7:0) when changing band.
2	11MHZ	11 MHz. NOTE: Also set the TUNING value (bits 7:0) when changing band.
3	14MHZ	14 MHz. NOTE: Also set the TUNING value (bits 7:0) when changing band.
4	21MHZ	21 MHz. NOTE: Also set the TUNING value (bits 7:0) when changing band.
5	28MHZ	28 MHz. NOTE: Also set the TUNING value (bits 7:0) when changing band.

7:0	TUNING	0x80	RW	HFRCO Tuning Value Writing this field adjusts the HFRCO frequency (the higher value, the higher frequency). This field is updated with the production calibrated value for the 14 MHz band during reset, and the reset value might therefore vary between devices.
-----	--------	------	----	--

11.5.5 CMU_LFRCTRL - LFRCO Control Register

Offset	Bit Position																															
0x010	31	30	29	28	27	26	25	24	23	22	21	20	19	18	17	16	15	14	13	12	11	10	9	8	7	6	5	4	3	2	1	0
Reset																									0x40							
Access																									RW							
Name																									TUNING							

Bit	Name	Reset	Access	Description
31:7	Reserved	To ensure compatibility with future devices, always write bits to 0. More information in Section 2.1 (p. 3)		

6:0	TUNING	0x40	RW	LFRCO Tuning Value Writing this field adjusts the LFRCO frequency (the higher value, the higher frequency). This field is updated with the production calibrated value during reset, and the reset value might therefore vary between devices.
-----	--------	------	----	--

11.5.6 CMU_AUXHFRCOCTRL - AUXHFRCO Control Register

Offset	Bit Position																															
0x014	31	30	29	28	27	26	25	24	23	22	21	20	19	18	17	16	15	14	13	12	11	10	9	8	7	6	5	4	3	2	1	0
Reset																									0x80							
Access																									RW							
Name																									TUNING							

Bit	Name	Reset	Access	Description
31:8	Reserved	To ensure compatibility with future devices, always write bits to 0. More information in Section 2.1 (p. 3)		
7:0	TUNING	0x80	RW	AUXHFRCO Tuning Value This value has been set during calibration and should not be changed.

11.5.7 CMU_CALCTRL - Calibration Control Register

Offset	Bit Position																															
0x018	31	30	29	28	27	26	25	24	23	22	21	20	19	18	17	16	15	14	13	12	11	10	9	8	7	6	5	4	3	2	1	0
Reset																									0x0							
Access																									RW							
Name																									UPSEL							

Bit	Name	Reset	Access	Description
31:3	Reserved	To ensure compatibility with future devices, always write bits to 0. More information in Section 2.1 (p. 3)		
2:0	UPSEL	0x0	RW	Calibration Up-counter Select Selects clock source for the calibration up-counter

Value	Mode	Description
0	HFXO	Select HFXO as up-counter
1	LFXO	Select LFXO as up-counter
2	HFRCO	Select HFRCO as up-counter
3	LFRCO	Select LFRCO as up-counter
4	AUXHFRCO	Select AUXHFRCO as up-counter

11.5.8 CMU_CALCNT - Calibration Counter Register

Offset	Bit Position																															
	31	30	29	28	27	26	25	24	23	22	21	20	19	18	17	16	15	14	13	12	11	10	9	8	7	6	5	4	3	2	1	0
0x01C																																
Reset																				0x00000												
Access																				RWH												
Name																				CALCNT												

Bit	Name	Reset	Access	Description
31:20	Reserved	To ensure compatibility with future devices, always write bits to 0. More information in Section 2.1 (p. 3)		
19:0	CALCNT	0x00000	RWH	Calibration Counter Write top value before calibration. Read calibration result from this register when Calibration Ready flag has been set.

11.5.9 CMU_OSCENCMD - Oscillator Enable/Disable Command Register

Offset	Bit Position																															
	31	30	29	28	27	26	25	24	23	22	21	20	19	18	17	16	15	14	13	12	11	10	9	8	7	6	5	4	3	2	1	0
0x020																																
Reset																						0										
Access																						W1										
Name																						LFXODIS, LFXOEN, LFRCODIS, LFRCOEN, AUXHFRCODIS, AUXHFRCOEN, HFXODIS, HFXOEN, HFRCODIS, HFRCOEN										

Bit	Name	Reset	Access	Description
31:10	Reserved	To ensure compatibility with future devices, always write bits to 0. More information in Section 2.1 (p. 3)		
9	LFXODIS	0	W1	LFXO Disable Disables the LFXO. LFXOEN has higher priority if written simultaneously.
8	LFXOEN	0	W1	LFXO Enable Enables the LFXO.
7	LFRCODIS	0	W1	LFRCO Disable Disables the LFRCO. LFRCOEN has higher priority if written simultaneously.
6	LFRCOEN	0	W1	LFRCO Enable Enables the LFRCO.
5	AUXHFRCODIS	0	W1	AUXHFRCO Disable Disables the AUXHFRCO. AUXHFRCOEN has higher priority if written simultaneously. WARNING: Do not disable this clock during a flash erase/write operation.
4	AUXHFRCOEN	0	W1	AUXHFRCO Enable Enables the AUXHFRCO.
3	HFXODIS	0	W1	HFXO Disable Disables the HFXO. HFXOEN has higher priority if written simultaneously. WARNING: Do not disable the HFRXO if this oscillator is selected as the source for HFCLK.

Bit	Name	Reset	Access	Description
2	HFXOEN Enables the HFXO.	0	W1	HFXO Enable
1	HFRCODIS Disables the HFRCO. HFRCOEN has higher priority if written simultaneously. WARNING: Do not disable the HFRCO if this oscillator is selected as the source for HFCLK.	0	W1	HFRCO Disable
0	HFRCOEN Enables the HFRCO.	0	W1	HFRCO Enable

11.5.10 CMU_CMD - Command Register

Offset	Bit Position																															
0x024	31	30	29	28	27	26	25	24	23	22	21	20	19	18	17	16	15	14	13	12	11	10	9	8	7	6	5	4	3	2	1	0
Reset																											0	0x0				
Access																											W1	W1				
Name																											CALSTART		HFCLKSEL			

Bit	Name	Reset	Access	Description
31:4	Reserved	To ensure compatibility with future devices, always write bits to 0. More information in Section 2.1 (p. 3)		
3	CALSTART Starts the calibration, effectively loading the CMU_CALCNT into the down-counter and start decrementing.	0	W1	Calibration Start
2:0	HFCLKSEL Selects the clock source for HFCLK. Note that selecting an oscillator that is disabled will cause the system clock to stop. Check the status register and confirm that oscillator is ready before switching.	0x0	W1	HFCLK Select

Value	Mode	Description
1	HFRCO	Select HFRCO as HFCLK
2	HFXO	Select HFXO as HFCLK
3	LFRCO	Select LFRCO as HFCLK
4	LFXO	Select LFXO as HFCLK

11.5.11 CMU_LFCLKSEL - Low Frequency Clock Select Register

Offset	Bit Position																															
0x028	31	30	29	28	27	26	25	24	23	22	21	20	19	18	17	16	15	14	13	12	11	10	9	8	7	6	5	4	3	2	1	0
Reset																											0x1	0x1				
Access																											RW	RW				
Name																											LFB		LFA			

Bit	Name	Reset	Access	Description
31:4	Reserved	To ensure compatibility with future devices, always write bits to 0. More information in Section 2.1 (p. 3)		
3:2	LFB Selects the clock source for LFBCLK	0x1	RW	Clock Select for LFB

Value	Mode	Description
0	DISABLED	LFCLK is disabled

Bit	Name	Reset	Access	Description
	Value	Mode		Description
1	LFRCO			LFRCO selected as LFBCLK
2	LFXO			LFXO selected as LFBCLK
3	HFCORECLKLEDIV2			HFCORECLK _{LE} divided by two is selected as LFBCLK
1:0	LFA	0x1	RW	Clock Select for LFA
Selects the clock source for LFACLK.				
	Value	Mode		Description
0	DISABLED			LFACLK is disabled
1	LFRCO			LFRCO selected as LFACLK
2	LFXO			LFXO selected as LFACLK
3	HFCORECLKLEDIV2			HFCORECLK _{LE} divided by two is selected as LFACLK

11.5.12 CMU_STATUS - Status Register

Offset	Bit Position																																																
0x02C	31	30	29	28	27	26	25	24	23	22	21	20	19	18	17	16	15	14	13	12	11	10	9	8	7	6	5	4	3	2	1	0																	
Reset																0	0	0	0	1	0	0	0	0	0	0	0	0	0	0	0	0	0	0	0	0	0	0	0	0	0	0	0	0	0	0	0		
Access																R	R	R	R	R	R	R	R	R	R	R	R	R	R	R	R	R	R	R	R	R	R	R	R	R	R	R	R	R	R	R	R	R	R
Name																CALBSY	LFXOSEL	LFRCOSEL	HFXOSEL	HFRCOSEL	LFXORDY	LFXOENS	LFRCORDY	LFRCOENS	AUXHFRCORDY	AUXHFRCOENS	HFXORDY	HFXOENS	HFRCORDY	HFRCOENS																			

Bit	Name	Reset	Access	Description
31:15	<i>Reserved</i>	<i>To ensure compatibility with future devices, always write bits to 0. More information in Section 2.1 (p. 3)</i>		
14	CALBSY	0	R	Calibration Busy Calibration is on-going.
13	LFXOSEL	0	R	LFXO Selected LFXO is selected as HFCLK clock source.
12	LFRCOSEL	0	R	LFRCO Selected LFRCO is selected as HFCLK clock source.
11	HFXOSEL	0	R	HFXO Selected HFXO is selected as HFCLK clock source.
10	HFRCOSEL	1	R	HFRCO Selected HFRCO is selected as HFCLK clock source.
9	LFXORDY	0	R	LFXO Ready LFXO is enabled and start-up time has exceeded.
8	LFXOENS	0	R	LFXO Enable Status LFXO is enabled.
7	LFRCORDY	0	R	LFRCO Ready LFRCO is enabled and start-up time has exceeded.
6	LFRCOENS	0	R	LFRCO Enable Status LFRCO is enabled.
5	AUXHFRCORDY	0	R	AUXHFRCO Ready AUXHFRCO is enabled and start-up time has exceeded.
4	AUXHFRCOENS	0	R	AUXHFRCO Enable Status AUXHFRCO is enabled.

Bit	Name	Reset	Access	Description
3	HFXORDY HFXO is enabled and start-up time has exceeded.	0	R	HFXO Ready
2	HFXOENS HFXO is enabled.	0	R	HFXO Enable Status
1	HFRCORDY HFRCO is enabled and start-up time has exceeded.	1	R	HFRCO Ready
0	HFRCOENS HFRCO is enabled.	1	R	HFRCO Enable Status

11.5.13 CMU_IF - Interrupt Flag Register

Offset	Bit Position																																																							
0x030	31	30	29	28	27	26	25	24	23	22	21	20	19	18	17	16	15	14	13	12	11	10	9	8	7	6	5	4	3	2	1	0																								
Reset																											R	0	R	0	R	0	R	0	R	0	R	0	R	0	R	0	R	0	R	0	R	0	R	0	R	0	R	1	R	1
Access																											R		R		R		R		R		R		R		R		R		R		R		R		R		R		R	
Name																																																			CALRDY	AUXHFRCORDY	LFXORDY	LFRCORDY	HFXORDY	HFRCORDY

Bit	Name	Reset	Access	Description
31:6	<i>Reserved</i>	<i>To ensure compatibility with future devices, always write bits to 0. More information in Section 2.1 (p. 3)</i>		
5	CALRDY Set when calibration is completed.	0	R	Calibration Ready Interrupt Flag
4	AUXHFRCORDY Set when AUXHFRCO is ready (start-up time exceeded).	0	R	AUXHFRCO Ready Interrupt Flag
3	LFXORDY Set when LFXO is ready (start-up time exceeded).	0	R	LFXO Ready Interrupt Flag
2	LFRCORDY Set when LFRCO is ready (start-up time exceeded).	0	R	LFRCO Ready Interrupt Flag
1	HFXORDY Set when HFXO is ready (start-up time exceeded).	0	R	HFXO Ready Interrupt Flag
0	HFRCORDY Set when HFRCO is ready (start-up time exceeded).	1	R	HFRCO Ready Interrupt Flag

11.5.14 CMU_IFS - Interrupt Flag Set Register

Offset	Bit Position																																																								
0x034	31	30	29	28	27	26	25	24	23	22	21	20	19	18	17	16	15	14	13	12	11	10	9	8	7	6	5	4	3	2	1	0																									
Reset																											W1	0	W1	0	W1	0	W1	0	W1	0	W1	0	W1	0	W1	0	W1	0	W1	0	W1	0	W1	0	W1	0	W1	0	W1	0	
Access																											W1		W1		W1		W1		W1		W1		W1		W1		W1		W1		W1		W1		W1		W1		W1		
Name																																																				CALRDY	AUXHFRCORDY	LFXORDY	LFRCORDY	HFXORDY	HFRCORDY

Bit	Name	Reset	Access	Description
31:6	Reserved	To ensure compatibility with future devices, always write bits to 0. More information in Section 2.1 (p. 3)		
5	CALRDY	0	W1	Calibration Ready Interrupt Flag Set Write to 1 to set the Calibration Ready(completed) Interrupt Flag
4	AUXHFRCORDY	0	W1	AUXHFRCO Ready Interrupt Flag Set Write to 1 to set the AUXHFRCO Ready Interrupt Flag
3	LFXORDY	0	W1	LFXO Ready Interrupt Flag Set Write to 1 to set the LFXO Ready Interrupt Flag
2	LFRCORDY	0	W1	LFRCO Ready Interrupt Flag Set Write to 1 to set the LFRCO Ready Interrupt Flag
1	HFXORDY	0	W1	HFXO Ready Interrupt Flag Set Write to 1 to set the HFXO Ready Interrupt Flag
0	HFRCORDY	0	W1	HFRCO Ready Interrupt Flag Set Write to 1 to set the HFRCO Ready Interrupt Flag

11.5.15 CMU_IFC - Interrupt Flag Clear Register

Offset	Bit Position																															
0x038	31	30	29	28	27	26	25	24	23	22	21	20	19	18	17	16	15	14	13	12	11	10	9	8	7	6	5	4	3	2	1	0
Reset																											0	0	0	0	0	0
Access																											W1	W1	W1	W1	W1	W1
Name																											CALRDY	AUXHFRCORDY	LFXORDY	LFRCORDY	HFXORDY	HFRCORDY

Bit	Name	Reset	Access	Description
31:6	Reserved	To ensure compatibility with future devices, always write bits to 0. More information in Section 2.1 (p. 3)		
5	CALRDY	0	W1	Calibration Ready Interrupt Flag Clear Write to 1 to clear the Calibration Ready Interrupt Flag
4	AUXHFRCORDY	0	W1	AUXHFRCO Ready Interrupt Flag Clear Write to 1 to clear the AUXHFRCO Ready Interrupt Flag
3	LFXORDY	0	W1	LFXO Ready Interrupt Flag Clear Write to 1 to clear the LFXO Ready Interrupt Flag
2	LFRCORDY	0	W1	LFRCO Ready Interrupt Flag Clear Write to 1 to clear the LFRCO Ready Interrupt Flag
1	HFXORDY	0	W1	HFXO Ready Interrupt Flag Clear Write to 1 to clear the HFXO Ready Interrupt Flag
0	HFRCORDY	0	W1	HFRCO Ready Interrupt Flag Clear Write to 1 to clear the HFRCO Ready Interrupt Flag

11.5.16 CMU_IEN - Interrupt Enable Register

Offset	Bit Position																															
0x03C	31	30	29	28	27	26	25	24	23	22	21	20	19	18	17	16	15	14	13	12	11	10	9	8	7	6	5	4	3	2	1	0
Reset																											0	0	0	0	0	0
Access																											RW	RW	RW	RW	RW	RW
Name																											CALRDY	AUXHFCORDY	LFXORDY	LFRCORDY	HFXORDY	HFCORDY

Bit	Name	Reset	Access	Description
31:6	<i>Reserved</i>	<i>To ensure compatibility with future devices, always write bits to 0. More information in Section 2.1 (p. 3)</i>		
5	CALRDY	0	RW	Calibration Ready Interrupt Enable Set to enable the Calibration Ready Interrupt.
4	AUXHFCORDY	0	RW	AUXHFCO Ready Interrupt Enable Set to enable the AUXHFCO Ready Interrupt.
3	LFXORDY	0	RW	LFXO Ready Interrupt Enable Set to enable the LFXO Ready Interrupt.
2	LFRCORDY	0	RW	LFRCO Ready Interrupt Enable Set to enable the LFRCO Ready Interrupt.
1	HFXORDY	0	RW	HFXO Ready Interrupt Enable Set to enable the HFXO Ready Interrupt.
0	HFCORDY	0	RW	HFCO Ready Interrupt Enable Set to enable the HFCO Ready Interrupt.

11.5.17 CMU_HFCORECLKEN0 - High Frequency Core Clock Enable Register 0

Offset	Bit Position																															
0x040	31	30	29	28	27	26	25	24	23	22	21	20	19	18	17	16	15	14	13	12	11	10	9	8	7	6	5	4	3	2	1	0
Reset																											0	0	0	0		
Access																											RW	RW	RW	RW		
Name																											EBI	LE	DMA	AES		

Bit	Name	Reset	Access	Description
31:4	<i>Reserved</i>	<i>To ensure compatibility with future devices, always write bits to 0. More information in Section 2.1 (p. 3)</i>		
3	EBI	0	RW	External Bus Interface Clock Enable Set to enable the clock for EBI.
2	LE	0	RW	Low Energy Peripheral Interface Clock Enable Set to enable the clock for LE. Interface used for bus access to Low Energy peripherals.
1	DMA	0	RW	Direct Memory Access Controller Clock Enable Set to enable the clock for DMA.
0	AES	0	RW	Advanced Encryption Standard Accelerator Clock Enable Set to enable the clock for AES.

11.5.18 CMU_HFPERCLKEN0 - High Frequency Peripheral Clock Enable Register 0

Offset	Bit Position																																																				
0x044	31	30	29	28	27	26	25	24	23	22	21	20	19	18	17	16	15	14	13	12	11	10	9	8	7	6	5	4	3	2	1	0																					
Reset																	0	0	0	0	0	0		0	0	0	0	0	0	0	0	0	0	0	0	0	0	0	0	0	0	0	0	0	0	0	0	0					
Access																	RW	RW	RW	RW	RW	RW		RW	RW	RW	RW	RW	RW	RW	RW	RW	RW	RW	RW	RW	RW	RW	RW	RW	RW	RW	RW	RW	RW	RW	RW	RW	RW	RW	RW	RW	
Name																	I2C0	ADC0	VCMP	GPIO	DAC0	PRS		ACMP1	ACMP0	TIMER2	TIMER1	TIMER0	UART0	USART2	USART1	USART0																					

Bit	Name	Reset	Access	Description
31:16	<i>Reserved</i>	<i>To ensure compatibility with future devices, always write bits to 0. More information in Section 2.1 (p. 3)</i>		
15	I2C0	0	RW	I2C 0 Clock Enable Set to enable the clock for I2C0.
14	ADC0	0	RW	Analog to Digital Converter 0 Clock Enable Set to enable the clock for ADC0.
13	VCMP	0	RW	Voltage Comparator Clock Enable Set to enable the clock for VCMP.
12	GPIO	0	RW	General purpose Input/Output Clock Enable Set to enable the clock for GPIO.
11	DAC0	0	RW	Digital to Analog Converter 0 Clock Enable Set to enable the clock for DAC0.
10	PRS	0	RW	Peripheral Reflex System Clock Enable Set to enable the clock for PRS.
9	<i>Reserved</i>	<i>To ensure compatibility with future devices, always write bits to 0. More information in Section 2.1 (p. 3)</i>		
8	ACMP1	0	RW	Analog Comparator 1 Clock Enable Set to enable the clock for ACMP1.
7	ACMP0	0	RW	Analog Comparator 0 Clock Enable Set to enable the clock for ACMP0.
6	TIMER2	0	RW	Timer 2 Clock Enable Set to enable the clock for TIMER2.
5	TIMER1	0	RW	Timer 1 Clock Enable Set to enable the clock for TIMER1.
4	TIMER0	0	RW	Timer 0 Clock Enable Set to enable the clock for TIMER0.
3	UART0	0	RW	Universal Asynchronous Receiver/Transmitter 0 Clock Enable Set to enable the clock for UART0.
2	USART2	0	RW	Universal Synchronous/Asynchronous Receiver/Transmitter 2 Clock Enable Set to enable the clock for USART2.
1	USART1	0	RW	Universal Synchronous/Asynchronous Receiver/Transmitter 1 Clock Enable Set to enable the clock for USART1.
0	USART0	0	RW	Universal Synchronous/Asynchronous Receiver/Transmitter 0 Clock Enable Set to enable the clock for USART0.

11.5.19 CMU_SYNCBUSY - Synchronization Busy Register

Offset	Bit Position																																																									
0x050	31	30	29	28	27	26	25	24	23	22	21	20	19	18	17	16	15	14	13	12	11	10	9	8	7	6	5	4	3	2	1	0																										
Reset																											R	0			R	0			R	0			R	0			R	0			R	0			R	0			R	0		
Access																											R				R				R				R				R				R				R				R			
Name																											LFBPRESC0				LFBCLKEN0				LFAPRESC0				LFBPRESC0				LFBCLKEN0				LFAPRESC0				LFBPRESC0				LFBCLKEN0			

Bit	Name	Reset	Access	Description
31:7	<i>Reserved</i>	<i>To ensure compatibility with future devices, always write bits to 0. More information in Section 2.1 (p. 3)</i>		
6	LFBPRESC0	0	R	Low Frequency B Prescaler 0 Busy Used to check the synchronization status of CMU_LFBPRESC0.
Value		Description		
1		CMU_LFBPRESC0 is busy synchronizing new value		
5	<i>Reserved</i>	<i>To ensure compatibility with future devices, always write bits to 0. More information in Section 2.1 (p. 3)</i>		
4	LFBCLKEN0	0	R	Low Frequency B Clock Enable 0 Busy Used to check the synchronization status of CMU_LFBCLKEN0.
Value		Description		
0		CMU_LFBCLKEN0 is ready for update		
1		CMU_LFBCLKEN0 is busy synchronizing new value		
3	<i>Reserved</i>	<i>To ensure compatibility with future devices, always write bits to 0. More information in Section 2.1 (p. 3)</i>		
2	LFAPRESC0	0	R	Low Frequency A Prescaler 0 Busy Used to check the synchronization status of CMU_LFAPRESC0.
Value		Description		
0		CMU_LFAPRESC0 is ready for update		
1		CMU_LFAPRESC0 is busy synchronizing new value		
1	<i>Reserved</i>	<i>To ensure compatibility with future devices, always write bits to 0. More information in Section 2.1 (p. 3)</i>		
0	LFACLKEN0	0	R	Low Frequency A Clock Enable 0 Busy Used to check the synchronization status of CMU_LFACLKEN0.
Value		Description		
0		CMU_LFACLKEN0 is ready for update		
1		CMU_LFACLKEN0 is busy synchronizing new value		

11.5.20 CMU_FREEZE - Freeze Register

Offset	Bit Position																																																										
0x054	31	30	29	28	27	26	25	24	23	22	21	20	19	18	17	16	15	14	13	12	11	10	9	8	7	6	5	4	3	2	1	0																											
Reset																																																										0	
Access																																																											RW
Name																																																											REGFREEZE

Bit	Name	Reset	Access	Description
31:1	Reserved	To ensure compatibility with future devices, always write bits to 0. More information in Section 2.1 (p. 3)		
0	REGFREEZE	0	RW	Register Update Freeze When set, the update of the Low Frequency clock control registers is postponed until this bit is cleared. Use this bit to update several registers simultaneously.
	Value	Mode	Description	
	0	UPDATE	Each write access to a Low Frequency clock control register is updated into the Low Frequency domain as soon as possible.	
	1	FREEZE	The LE Clock Control registers are not updated with the new written value.	

11.5.21 CMU_LFACLKEN0 - Low Frequency A Clock Enable Register 0 (Async Reg)

Offset	Bit Position																															
0x058	31	30	29	28	27	26	25	24	23	22	21	20	19	18	17	16	15	14	13	12	11	10	9	8	7	6	5	4	3	2	1	0
Reset																											0	0	0			
Access																											RW	RW	RW			
Name																											LCD	LETIMER0	RTC			

Bit	Name	Reset	Access	Description
31:3	Reserved	To ensure compatibility with future devices, always write bits to 0. More information in Section 2.1 (p. 3)		
2	LCD	0	RW	Liquid Crystal Display Controller Clock Enable Set to enable the clock for LCD.
1	LETIMER0	0	RW	Low Energy Timer 0 Clock Enable Set to enable the clock for LETIMER0.
0	RTC	0	RW	Real-Time Counter Clock Enable Set to enable the clock for RTC.

11.5.22 CMU_LFBCLKEN0 - Low Frequency B Clock Enable Register 0 (Async Reg)

Offset	Bit Position																															
0x060	31	30	29	28	27	26	25	24	23	22	21	20	19	18	17	16	15	14	13	12	11	10	9	8	7	6	5	4	3	2	1	0
Reset																											0	0				
Access																											RW	RW				
Name																											LEUART1	LEUART0				

Bit	Name	Reset	Access	Description
31:2	Reserved	To ensure compatibility with future devices, always write bits to 0. More information in Section 2.1 (p. 3)		
1	LEUART1	0	RW	Low Energy UART 1 Clock Enable Set to enable the clock for LEUART1.
0	LEUART0	0	RW	Low Energy UART 0 Clock Enable Set to enable the clock for LEUART0.

11.5.23 CMU_LFAPRESC0 - Low Frequency A Prescaler Register 0 (Async Reg)

Offset	Bit Position																															
0x068	31	30	29	28	27	26	25	24	23	22	21	20	19	18	17	16	15	14	13	12	11	10	9	8	7	6	5	4	3	2	1	0
Reset																						0x0		0x0		0x0						
Access																						RW		RW		RW						
Name																						LCD		LETIMER0		RTC						

Bit	Name	Reset	Access	Description
31:10	Reserved	To ensure compatibility with future devices, always write bits to 0. More information in Section 2.1 (p. 3)		

9:8	LCD	0x0	RW	Liquid Crystal Display Controller Prescaler Configure Liquid Crystal Display Controller prescaler
-----	-----	-----	----	---

Value	Mode	Description
0	DIV16	LFACLK _{LCD} = LFACLK/16
1	DIV32	LFACLK _{LCD} = LFACLK/32
2	DIV64	LFACLK _{LCD} = LFACLK/64
3	DIV128	LFACLK _{LCD} = LFACLK/128

7:4	LETIMER0	0x0	RW	Low Energy Timer 0 Prescaler Configure Low Energy Timer 0 prescaler
-----	----------	-----	----	---

Value	Mode	Description
0	DIV1	LFACLK _{LETIMER0} = LFACLK
1	DIV2	LFACLK _{LETIMER0} = LFACLK/2
2	DIV4	LFACLK _{LETIMER0} = LFACLK/4
3	DIV8	LFACLK _{LETIMER0} = LFACLK/8
4	DIV16	LFACLK _{LETIMER0} = LFACLK/16
5	DIV32	LFACLK _{LETIMER0} = LFACLK/32
6	DIV64	LFACLK _{LETIMER0} = LFACLK/64
7	DIV128	LFACLK _{LETIMER0} = LFACLK/128
8	DIV256	LFACLK _{LETIMER0} = LFACLK/256
9	DIV512	LFACLK _{LETIMER0} = LFACLK/512
10	DIV1024	LFACLK _{LETIMER0} = LFACLK/1024
11	DIV2048	LFACLK _{LETIMER0} = LFACLK/2048
12	DIV4096	LFACLK _{LETIMER0} = LFACLK/4096
13	DIV8192	LFACLK _{LETIMER0} = LFACLK/8192
14	DIV16384	LFACLK _{LETIMER0} = LFACLK/16384
15	DIV32768	LFACLK _{LETIMER0} = LFACLK/32768

3:0	RTC	0x0	RW	Real-Time Counter Prescaler Configure Real-Time Counter prescaler
-----	-----	-----	----	---

Value	Mode	Description
0	DIV1	LFACLK _{RTC} = LFACLK
1	DIV2	LFACLK _{RTC} = LFACLK/2
2	DIV4	LFACLK _{RTC} = LFACLK/4
3	DIV8	LFACLK _{RTC} = LFACLK/8
4	DIV16	LFACLK _{RTC} = LFACLK/16
5	DIV32	LFACLK _{RTC} = LFACLK/32
6	DIV64	LFACLK _{RTC} = LFACLK/64
7	DIV128	LFACLK _{RTC} = LFACLK/128
8	DIV256	LFACLK _{RTC} = LFACLK/256
9	DIV512	LFACLK _{RTC} = LFACLK/512

Bit	Name	Reset	Access	Description
	Value	Mode		Description
10	DIV1024			LFACLK _{RTC} = LFACLK/1024
11	DIV2048			LFACLK _{RTC} = LFACLK/2048
12	DIV4096			LFACLK _{RTC} = LFACLK/4096
13	DIV8192			LFACLK _{RTC} = LFACLK/8192
14	DIV16384			LFACLK _{RTC} = LFACLK/16384
15	DIV32768			LFACLK _{RTC} = LFACLK/32768

11.5.24 CMU_LFBPRESC0 - Low Frequency B Prescaler Register 0 (Async Reg)

Offset	Bit Position																															
0x070	31	30	29	28	27	26	25	24	23	22	21	20	19	18	17	16	15	14	13	12	11	10	9	8	7	6	5	4	3	2	1	0
Reset																									0x0			0x0				
Access																									RW			RW				
Name																									LEUART1			LEUART0				

Bit	Name	Reset	Access	Description
31:6	Reserved	<i>To ensure compatibility with future devices, always write bits to 0. More information in Section 2.1 (p. 3)</i>		

Bit	Name	Reset	Access	Description
5:4	LEUART1	0x0	RW	Low Energy UART 1 Prescaler
Configure Low Energy UART 1 prescaler				
	Value	Mode		Description
	0	DIV1		LFBCLK _{LEUART1} = LFBCLK
	1	DIV2		LFBCLK _{LEUART1} = LFBCLK/2
	2	DIV4		LFBCLK _{LEUART1} = LFBCLK/4
	3	DIV8		LFBCLK _{LEUART1} = LFBCLK/8

3:2	Reserved	<i>To ensure compatibility with future devices, always write bits to 0. More information in Section 2.1 (p. 3)</i>		
-----	----------	--	--	--

Bit	Name	Reset	Access	Description
1:0	LEUART0	0x0	RW	Low Energy UART 0 Prescaler
Configure Low Energy UART 0 prescaler				
	Value	Mode		Description
	0	DIV1		LFBCLK _{LEUART0} = LFBCLK
	1	DIV2		LFBCLK _{LEUART0} = LFBCLK/2
	2	DIV4		LFBCLK _{LEUART0} = LFBCLK/4
	3	DIV8		LFBCLK _{LEUART0} = LFBCLK/8

11.5.25 CMU_PCNTCTRL - PCNT Control Register

Offset	Bit Position																															
0x078	31	30	29	28	27	26	25	24	23	22	21	20	19	18	17	16	15	14	13	12	11	10	9	8	7	6	5	4	3	2	1	0
Reset																									0	0	0	0	0	0		
Access																									RW	RW	RW	RW	RW	RW		
Name																									PCNT2CLKSEL	PCNT2CLKEN	PCNT1CLKSEL	PCNT1CLKEN	PCNT0CLKSEL	PCNT0CLKEN		

Bit	Name	Reset	Access	Description
31:6	Reserved	To ensure compatibility with future devices, always write bits to 0. More information in Section 2.1 (p. 3)		
5	PCNT2CLKSEL	0	RW	PCNT2 Clock Select This bit controls which clock that is used for the PCNT.
	Value	Mode	Description	
	0	LFACTK	LFACTK is clocking PCNT2	
	1	PCNT2S0	External pin PCNT2_S0 is clocking PCNT0	
4	PCNT2CLKEN	0	RW	PCNT2 Clock Enable This bit enables/disables the clock to the PCNT.
	Value	Description		
	0	PCNT2 is disabled		
	1	PCNT2 is enabled		
3	PCNT1CLKSEL	0	RW	PCNT1 Clock Select This bit controls which clock that is used for the PCNT.
	Value	Mode	Description	
	0	LFACTK	LFACTK is clocking PCNT0	
	1	PCNT1S0	External pin PCNT1_S0 is clocking PCNT0	
2	PCNT1CLKEN	0	RW	PCNT1 Clock Enable This bit enables/disables the clock to the PCNT.
	Value	Description		
	0	PCNT1 is disabled		
	1	PCNT1 is enabled		
1	PCNT0CLKSEL	0	RW	PCNT0 Clock Select This bit controls which clock that is used for the PCNT.
	Value	Mode	Description	
	0	LFACTK	LFACTK is clocking PCNT0	
	1	PCNT0S0	External pin PCNT0_S0 is clocking PCNT0	
0	PCNT0CLKEN	0	RW	PCNT0 Clock Enable This bit enables/disables the clock to the PCNT.

11.5.26 CMU_LCDCTRL - LCD Control Register

Offset	Bit Position																															
0x07C	31	30	29	28	27	26	25	24	23	22	21	20	19	18	17	16	15	14	13	12	11	10	9	8	7	6	5	4	3	2	1	0
Reset																									0x2		0	0x0				
Access																									RW		RW	RW				
Name																									VBFDIV		VBOOSTEN	FDIV				

Bit	Name	Reset	Access	Description
31:7	Reserved	To ensure compatibility with future devices, always write bits to 0. More information in Section 2.1 (p. 3)		
6:4	VBFDIV	0x2	RW	Voltage Boost Frequency Division These bits control the voltage boost update frequency division.
	Value	Mode	Description	
	0	DIV1	Voltage Boost update Frequency = LFACTK	
	1	DIV2	Voltage Boost update Frequency = LFACTK/2	

Bit	Name	Reset	Access	Description
	Value	Mode		Description
2	DIV4			Voltage Boost update Frequency = LFACLK/4
3	DIV8			Voltage Boost update Frequency = LFACLK/8
4	DIV16			Voltage Boost update Frequency = LFACLK/16
5	DIV32			Voltage Boost update Frequency = LFACLK/32
6	DIV64			Voltage Boost update Frequency = LFACLK/64
7	DIV128			Voltage Boost update Frequency = LFACLK/128
3	VBOOSTEN	0	RW	Voltage Boost Enable This bit enables/disables the VBOOST function.
2:0	FDIV	0x0	RW	Frame Rate Control These bits controls the framerate according to this formula: $LFACLK_{LCD} = LFACLK_{LCDpre} / (1 + FDIV)$. Do not change this value while the LCD bit in CMU_LFACLKEN0 is set to 1.

11.5.27 CMU_ROUTE - I/O Routing Register

Offset	Bit Position																															
0x080	31	30	29	28	27	26	25	24	23	22	21	20	19	18	17	16	15	14	13	12	11	10	9	8	7	6	5	4	3	2	1	0
Reset																												0	2			
Access																												RW	RW	RW		
Name																												LOCATION	CLKOUT1PEN	CLKOUT0PEN		
Bit	Name	Reset	Access	Description																												
31:3	Reserved			To ensure compatibility with future devices, always write bits to 0. More information in Section 2.1 (p. 3)																												
2	LOCATION	0	RW	I/O Location Decides the location of the CMU I/O pins.																												
	Value	Mode		Description																												
	0	LOC0		Location 0																												
	1	LOC1		Location 1																												
1	CLKOUT1PEN	0	RW	CLKOUT1 Pin Enable When set, the CLKOUT1 pin is enabled.																												
0	CLKOUT0PEN	0	RW	CLKOUT0 Pin Enable When set, the CLKOUT0 pin is enabled.																												

11.5.28 CMU_LOCK - Configuration Lock Register

Offset	Bit Position																																	
0x084	31	30	29	28	27	26	25	24	23	22	21	20	19	18	17	16	15	14	13	12	11	10	9	8	7	6	5	4	3	2	1	0		
Reset																																		0x0000
Access																																		RW
Name																																		LOCKKEY

Bit	Name	Reset	Access	Description
31:16	Reserved	To ensure compatibility with future devices, always write bits to 0. More information in Section 2.1 (p. 3)		

15:0 LOCKKEY 0x0000 RW **Configuration Lock Key**

Write any other value than the unlock code to lock CMU_CTRL, CMU_HFCORECLKDIV, CMU_HFPERCLKDIV, CMU_HFRCOCTRL, CMU_LFRCOCTRL, CMU_AUXHFRCOCTRL, CMU_OSCENCMD, CMU_CMD, CMU_LFCLKSEL, CMU_HFCORECLKEN0, CMU_HFPERCLKEN0, CMU_LFACLKEN0, CMU_LFBCLKEN0, CMU_LFAPRESC0, CMU_LFBPRESC0, and CMU_PCNTCTRL from editing. Write the unlock code to unlock. When reading the register, bit 0 is set when the lock is enabled.

Mode	Value	Description
Read Operation		
UNLOCKED	0	CMU registers are unlocked
LOCKED	1	CMU registers are locked
Write Operation		
LOCK	0	Lock CMU registers
UNLOCK	0x580E	Unlock CMU registers

12 WDOG - Watchdog Timer

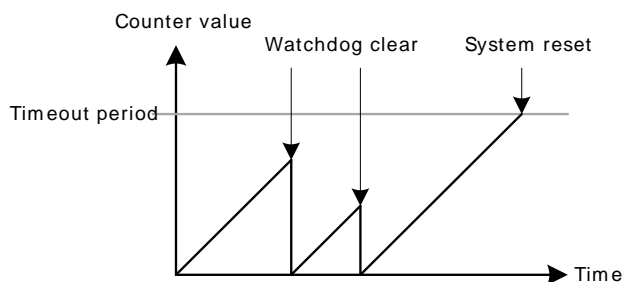
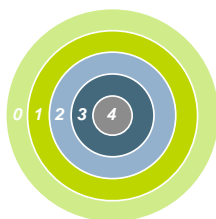

Quick Facts

What?

The WDOG (Watchdog Timer) resets the system in case of a fault condition, and can be enabled in all energy modes as long as the low frequency clock source is available.

Why?

If a software failure or external event renders the MCU unresponsive, a Watchdog timeout will reset the system to a known, safe state.

How?

An enabled Watchdog Timer implements a configurable timeout period. If the CPU fails to re-start the Watchdog Timer before it times out, a full system reset will be triggered. The Watchdog consumes insignificant power, and allows the device to remain safely in low energy modes for up to 256 seconds at a time.

12.1 Introduction

The purpose of the watchdog timer is to generate a reset in case of a system failure, to increase application reliability. The failure may e.g. be caused by an external event, such as an ESD pulse, or by a software failure.

12.2 Features

- Clock input from selectable oscillators
 - Internal 32.768 kHz RC oscillator
 - Internal 1kHz RC oscillator
 - External 32.768 kHz XTAL oscillator
- Configurable timeout period from 9 to 256k watchdog clock cycles
- Individual selection to keep running or freeze when entering EM2 or EM3
- Selection to keep running or freeze when entering debug mode
- Selection to block the CPU from entering Energy Mode 4
- Selection to block the CMU from disabling the selected watchdog clock

12.3 Functional Description

The watchdog is enabled by setting the EN bit in WDOG_CTRL. When enabled, the watchdog counts up to the period value configured through the PERSEL field in WDOG_CTRL. If the watchdog timer is not cleared to 0 (by writing a 1 to the CLEAR bit in WDOG_CMD) before the period is reached, the chip is reset. If a timely clear command is issued, the timer starts counting up from 0 again. The watchdog can optionally be locked by writing the LOCK bit in WDOG_CTRL. Once locked, it cannot be disabled or reconfigured by software.

The watchdog counter is reset when EN is reset.

12.3.1 Clock Source

Three clock sources are available for use with the watchdog, through the CLKSEL field in WDOG_CTRL. The corresponding clocks must be enabled in the CMU. The SWOSCBLOCK bit in WDOG_CTRL can be written to prevent accidental disabling of the selected clocks. Also, setting this bit will automatically start the selected oscillator source when the watchdog is enabled. The PERSEL field in WDOG_CTRL is used to divide the selected watchdog clock, and the timeout for the watchdog timer can be calculated like this:

WDOG Timeout Equation

$$T_{\text{TIMEOUT}} = (2^{3+\text{PERSEL}} + 1)/f \quad (12.1)$$

where f is the frequency of the selected clock.

It is recommended to clear the watchdog first, if PERSEL is changed while the watchdog is enabled.

To use this module, the LE interface clock must be enabled in CMU_HFCORECLKEN0, in addition to the module clock.

12.3.2 Debug Functionality

The watchdog timer can either keep running or be frozen when the device enters debug mode. This configuration is done through the DEBUGRUN bit in WDOG_CTRL. When the device leaves debug mode, the watchdog will continue counting where it left off.

12.3.3 Energy Mode Handling

The watchdog timer can be configured to either keep on running or freeze when entering EM2 or EM3. The configuration is done individually for each energy mode in the EM2RUN and EM3RUN bits in WDOG_CTRL. When the watchdog has been frozen and is re-entering an energy mode where it is running, the watchdog timer will continue counting where it left off. For the watchdog there is no difference between EM0 and EM1. The watchdog does not run in EM4, and if writing to the EM4BLOCK bit in WDOG_CTRL, the CPU is prevented from entering EM4.

Note

If the WDOG is clocked by the LFXO or LFRCO, writing the SWOSCBLOCK bit will effectively prevent the CPU from entering EM3. When running from the ULFRCO, writing the SWOSCBLOCK bit will prevent the CPU from entering EM4.

12.3.4 Register access

Since this module is a Low Energy Peripheral, and runs off a clock which is asynchronous to the HFCORECLK, special considerations must be taken when accessing registers. Please refer to Section 5.3 (p. 18) for a description on how to perform register accesses to Low Energy Peripherals. note that clearing the EN bit in WDOG_CTRL will reset the WDOG module, which will halt any ongoing register synchronization.

12.4 Register Map

The offset register address is relative to the registers base address.

Offset	Name	Type	Description
0x000	WDOG_CTRL	RW	Control Register
0x004	WDOG_CMD	W1	Command Register
0x008	WDOG_SYNCBUSY	R	Synchronization Busy Register

12.5 Register Description

12.5.1 WDOG_CTRL - Control Register (Async Reg)

For more information about Asynchronous Registers please see Section 5.3 (p. 18) .

Offset	Bit Position																																							
0x000	31	30	29	28	27	26	25	24	23	22	21	20	19	18	17	16	15	14	13	12	11	10	9	8	7	6	5	4	3	2	1	0								
Reset																				0x0							0xF													
Access																				RW							RW													
Name																				CLKSEL							PERSEL							SWOSCBLOCK	EM4BLOCK	LOCK	EM3RUN	EM2RUN	DEBUGRUN	EN

Bit	Name	Reset	Access	Description
31:14	Reserved	To ensure compatibility with future devices, always write bits to 0. More information in Section 2.1 (p. 3)		

13:12 CLKSEL 0x0 RW **Watchdog Clock Select**

Selects the WDOG oscillator, ie. the clock on which the watchdog will run.

Value	Mode	Description
0	ULFRCO	ULFRCO
1	LFRCO	LFRCO
2	LFXO	LFXO

11:8 PERSEL 0xF RW **Watchdog Timeout Period Select.**

Select watchdog timeout period.

Value	Description
0	Timeout period of 9 watchdog clock cycles.
1	Timeout period of 17 watchdog clock cycles.
2	Timeout period of 33 watchdog clock cycles.
3	Timeout period of 65 watchdog clock cycles.
4	Timeout period of 129 watchdog clock cycles.
5	Timeout period of 257 watchdog clock cycles.
6	Timeout period of 513 watchdog clock cycles.
7	Timeout period of 1k watchdog clock cycles.
8	Timeout period of 2k watchdog clock cycles.
9	Timeout period of 4k watchdog clock cycles.
10	Timeout period of 8k watchdog clock cycles.
11	Timeout period of 16k watchdog clock cycles.
12	Timeout period of 32k watchdog clock cycles.
13	Timeout period of 64k watchdog clock cycles.
14	Timeout period of 128k watchdog clock cycles.
15	Timeout period of 256k watchdog clock cycles.

Bit	Name	Reset	Access	Description						
7	Reserved	To ensure compatibility with future devices, always write bits to 0. More information in Section 2.1 (p. 3)								
6	SWOSCBLOCK	0	RW	Software Oscillator Disable Block Set to disallow disabling of the selected WDOG oscillator. Writing this bit to 1 will turn on the selected WDOG oscillator if it is not already running. <table border="1"> <thead> <tr> <th>Value</th> <th>Description</th> </tr> </thead> <tbody> <tr> <td>0</td> <td>Software is allowed to disable the selected WDOG oscillator. See CMU for detailed description. Note that also CMU registers are lockable.</td> </tr> <tr> <td>1</td> <td>Software is not allowed to disable the selected WDOG oscillator.</td> </tr> </tbody> </table>	Value	Description	0	Software is allowed to disable the selected WDOG oscillator. See CMU for detailed description. Note that also CMU registers are lockable.	1	Software is not allowed to disable the selected WDOG oscillator.
Value	Description									
0	Software is allowed to disable the selected WDOG oscillator. See CMU for detailed description. Note that also CMU registers are lockable.									
1	Software is not allowed to disable the selected WDOG oscillator.									
5	EM4BLOCK	0	RW	Energy Mode 4 Block Set to prevent the EMU from entering EM4 <table border="1"> <thead> <tr> <th>Value</th> <th>Description</th> </tr> </thead> <tbody> <tr> <td>0</td> <td>EM4 can be entered. See EMU for detailed description.</td> </tr> <tr> <td>1</td> <td>EM4 cannot be entered.</td> </tr> </tbody> </table>	Value	Description	0	EM4 can be entered. See EMU for detailed description.	1	EM4 cannot be entered.
Value	Description									
0	EM4 can be entered. See EMU for detailed description.									
1	EM4 cannot be entered.									
4	LOCK	0	RW	Configuration lock Set to lock the watchdog configuration. This bit can only be cleared by reset. <table border="1"> <thead> <tr> <th>Value</th> <th>Description</th> </tr> </thead> <tbody> <tr> <td>0</td> <td>Watchdog configuration can be changed.</td> </tr> <tr> <td>1</td> <td>Watchdog configuration cannot be changed.</td> </tr> </tbody> </table>	Value	Description	0	Watchdog configuration can be changed.	1	Watchdog configuration cannot be changed.
Value	Description									
0	Watchdog configuration can be changed.									
1	Watchdog configuration cannot be changed.									
3	EM3RUN	0	RW	Energy Mode 3 Run Enable Set to keep watchdog running in EM3. <table border="1"> <thead> <tr> <th>Value</th> <th>Description</th> </tr> </thead> <tbody> <tr> <td>0</td> <td>Watchdog timer is frozen in EM3.</td> </tr> <tr> <td>1</td> <td>Watchdog timer is running in EM3.</td> </tr> </tbody> </table>	Value	Description	0	Watchdog timer is frozen in EM3.	1	Watchdog timer is running in EM3.
Value	Description									
0	Watchdog timer is frozen in EM3.									
1	Watchdog timer is running in EM3.									
2	EM2RUN	0	RW	Energy Mode 2 Run Enable Set to keep watchdog running in EM2 <table border="1"> <thead> <tr> <th>Value</th> <th>Description</th> </tr> </thead> <tbody> <tr> <td>0</td> <td>Watchdog timer is frozen in EM2.</td> </tr> <tr> <td>1</td> <td>Watchdog timer is running in EM2.</td> </tr> </tbody> </table>	Value	Description	0	Watchdog timer is frozen in EM2.	1	Watchdog timer is running in EM2.
Value	Description									
0	Watchdog timer is frozen in EM2.									
1	Watchdog timer is running in EM2.									
1	DEBUGRUN	0	RW	Debug Mode Run Enable Set to keep watchdog running in debug mode. <table border="1"> <thead> <tr> <th>Value</th> <th>Description</th> </tr> </thead> <tbody> <tr> <td>0</td> <td>Watchdog timer is frozen in debug mode.</td> </tr> <tr> <td>1</td> <td>Watchdog timer is running in debug mode.</td> </tr> </tbody> </table>	Value	Description	0	Watchdog timer is frozen in debug mode.	1	Watchdog timer is running in debug mode.
Value	Description									
0	Watchdog timer is frozen in debug mode.									
1	Watchdog timer is running in debug mode.									
0	EN	0	RW	Watchdog Timer Enable Set to enabled watchdog timer.						

12.5.2 WDOG_CMD - Command Register (Async Reg)

For more information about Asynchronous Registers please see Section 5.3 (p. 18) .

Offset	Bit Position																															
0x004	31	30	29	28	27	26	25	24	23	22	21	20	19	18	17	16	15	14	13	12	11	10	9	8	7	6	5	4	3	2	1	0
Reset																		0	0													
Access																		W1														
Name																		CLEAR														

Bit	Name	Reset	Access	Description
31:1	Reserved	To ensure compatibility with future devices, always write bits to 0. More information in Section 2.1 (p. 3)		
0	CLEAR	0	W1	Watchdog Timer Clear Clear watchdog timer. The bit must be written 4 watchdog cycles before the timeout.
	Value	Mode	Description	
	0	UNCHANGED	Watchdog timer is unchanged.	
	1	CLEARED	Watchdog timer is cleared to 0.	

12.5.3 WDOG_SYNCBUSY - Synchronization Busy Register

Offset	Bit Position																																	
0x008	31	30	29	28	27	26	25	24	23	22	21	20	19	18	17	16	15	14	13	12	11	10	9	8	7	6	5	4	3	2	1	0		
Reset																															R	0	R	0
Access																															R		R	
Name																															CMD		CTRL	

Bit	Name	Reset	Access	Description
31:2	Reserved	To ensure compatibility with future devices, always write bits to 0. More information in Section 2.1 (p. 3)		
1	CMD	0	R	WDOG_CMD Register Busy Set when the value written to WDOG_CMD is being synchronized.
0	CTRL	0	R	WDOG_CTRL Register Busy Set when the value written to WDOG_CTRL is being synchronized.

13 PRS - Peripheral Reflex System

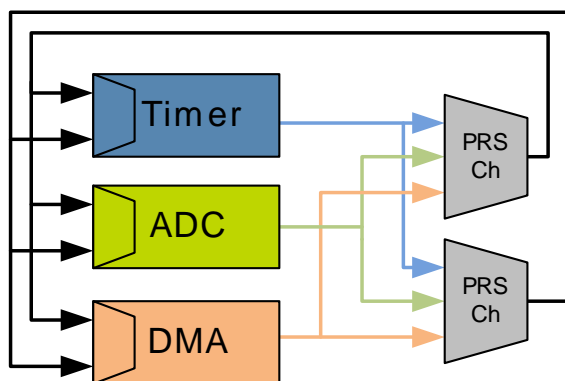
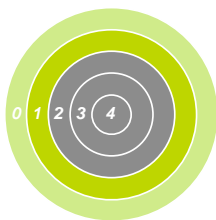

Quick Facts

What?

The PRS (Peripheral Reflex System) allows configurable, fast, and autonomous communication between the peripherals.

Why?

Events and signals from one peripheral can be used as input signals or triggers by other peripherals and ensure timing-critical operation and reduced software overhead.

How?

Without CPU intervention the peripherals can send Reflex signals (both pulses and level) to each other in single- or chained steps. The peripherals can be set up to perform actions based on the incoming Reflex signals. This results in improved system performance and reduced energy consumption.

13.1 Introduction

The Peripheral Reflex System (PRS) system is a network which lets the different peripheral module communicate directly with each other without involving the CPU. Peripheral modules which send out Reflex signals are called producers. The PRS routes these reflex signals to consumer peripherals which apply actions depending on the Reflex signals received. The format for the Reflex signals is not given, but edge triggers and other functionality can be applied by the PRS.

13.2 Features

- 8 configurable interconnect channels
 - Each channel can be connected to any producing peripheral
 - Consumers can choose which channel to listen to
 - Selectable edge detector (Rising, falling and both edges)
- Software controlled channel output
 - Configurable level
 - Triggered pulses

13.3 Functional Description

An overview of the PRS module is shown in Figure 13.1 (p. 127). The PRS contains 8 interconnect channels, and each of these can select between all the output Reflex signals offered by the producers. The consumers can then choose which PRS channel to listen to and perform actions based on the Reflex signals routed through that channel. The Reflex signals can be both pulse signals and level signals. Synchronous PRS pulses are one HFPERCLK cycle long, and can either be sent out by a producer (e.g. ADC conversion complete) or be generated from the edge detector in the PRS channel. Level signals can have an arbitrary waveform (e.g. Timer PWM output).

13.3.1 Channel Functions

Different functions can be applied to a reflex signal within the PRS. Each channel includes an edge detector to enable generation of pulse signals from level signals. It is also possible to generate output Reflex signals by configuring the SWPULSE and SWLEVEL bits. SWLEVEL is a programmable level for each channel and holds the value it is programmed to. The SWPULSE will give out a one-cycle high pulse if it is written to 1, otherwise a 0 is asserted. The SWLEVEL and SWPULSE signals are then XOR'ed with the selected input from the producers to form the output signal sent to the consumers listening to the channel.

Figure 13.1. PRS Overview

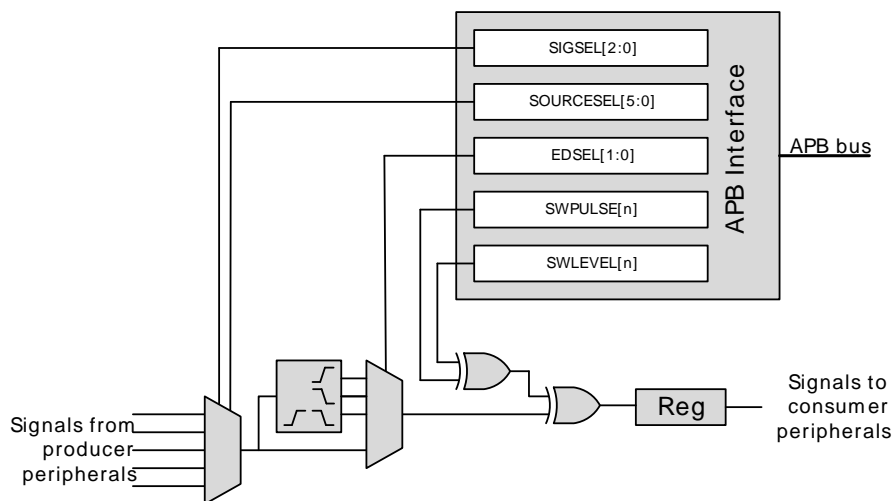

13.3.2 Producers

Each PRS channel can choose between signals from several producers, which is configured in SOURCESEL in PRS_CHx_CTRL. Each of these producers outputs one or more signals which can be selected by setting the SIGSEL field in PRS_CHx_CTRL. Setting the SOURCESEL bits to 0 (Off) leads to a constant 0 output from the input mux. An overview of the available producers is given in Table 13.1 (p. 127) .

Table 13.1. Reflex Producers

Module	Reflex Output	Output Format
ACMP	Comparator Output	Level
ADC	Single Conversion Done	Pulse
	Scan Conversion Done	Pulse
DAC	Channel 0 Conversion Done	Pulse
	Channel 0 Conversion Done	Pulse
GPIO	Pin 0 Input	Level
	Pin 1 Input	Level
	Pin 2 Input	Level
	Pin 3 Input	Level
	Pin 4 Input	Level
	Pin 5 Input	Level
	Pin 6 Input	Level

Module	Reflex Output	Output Format
	Pin 7 Input	Level
	Pin 8 Input	Level
	Pin 9 Input	Level
	Pin 10 Input	Level
	Pin 11 Input	Level
	Pin 12 Input	Level
	Pin 13 Input	Level
	Pin 14 Input	Level
	Pin 15 Input	Level
RTC	Overflow	Pulse
	Compare Match 0	Pulse
	Compare Match 1	Pulse
TIMER	Underflow	Pulse
	Overflow	Pulse
	CC0 Output	Level
	CC1 Output	Level
	CC2 Output	Level
UART	TX Complete	Pulse
	RX Data Received	Pulse
USART	TX Complete	Pulse
	RX Data Received	Pulse
	IrDA Decoder Output	Level
VCMP	Comparator Output	Level

13.3.3 Consumers

Consumer peripherals (Listed in Table 13.2 (p. 128)) can be set to listen to a PRS channel and perform an action based on the signal received on that channel. Most consumers expect pulse input, while some can handle level inputs as well.

Table 13.2. Reflex Consumers

Module	Reflex Input	Input Format
ADC	Single Mode Trigger	Pulse
	Scan Mode Trigger	Pulse
DAC	Channel 0 Trigger	Pulse
	Channel 1 Trigger	Pulse
TIMER	CC0 Input	Pulse/Level
	CC1 Input	Pulse/Level

Module	Reflex Input	Input Format
	CC2 Input	Pulse/Level
	DTI Fault Source 0 (TIMER0 only)	Pulse
	DTI Fault Source 1 (TIMER0 only)	Pulse
	DTI Input (TIMER0 only)	Pulse/Level
UART	TX/RX Enable	Pulse
USART	TX/RX Enable	Pulse
	IrDA Encoder Input (USART0 only)	Level

13.3.4 Example

The example below (illustrated in Figure 13.2 (p. 129)) shows how to set up ADC0 to start single conversions every time TIMER0 overflows (one HFPERCLK cycle high pulse), using PRS channel 5:

- Set SOURCESEL in PRS_CH5_CTRL to 0b011100 to select TIMER0 as input to PRS channel 5.
- Set SIGSEL in PRS_CH5_CTRL to 0b001 to select the overflow signal (from TIMER0).
- Configure ADC0 with the desired conversion set-up.
- Set SINGLEPRSEN in ADC0_SINGLECTRL to 1 to enable single conversions to be started by a high PRS input signal.
- Set SINGLEPRSSEL in ADC0_SINGLECTRL to 0x5 to select PRS channel 5 as input to start the single conversion.
- Start TIMER0 with the desired TOP value, an overflow PRS signal is output automatically on overflow.

Note that the ADC results needs to be fetched either by the CPU or DMA.

Figure 13.2. TIMER0 overflow starting ADC0 single conversions through PRS channel 5.

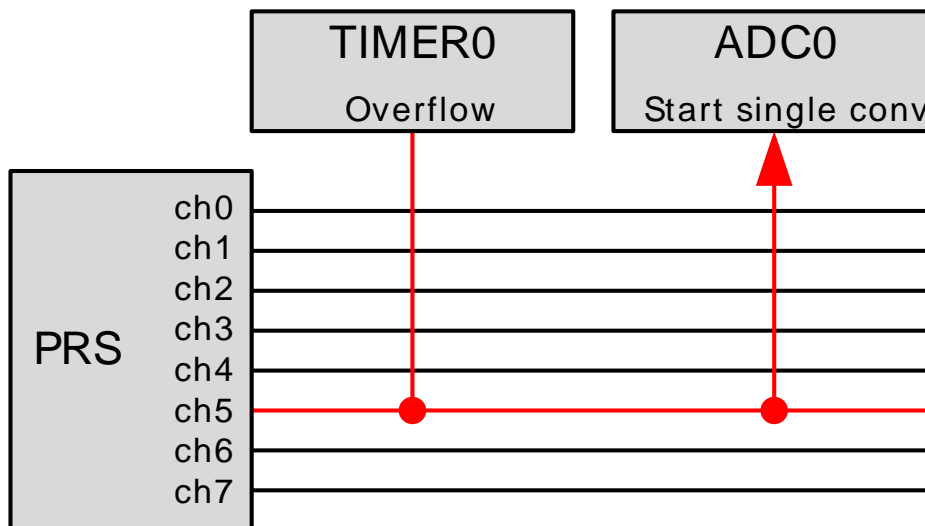

13.4 Register Map

The offset register address is relative to the registers base address.

Offset	Name	Type	Description
0x000	PRS_SWPULSE	W1	Software Pulse Register
0x004	PRS_SWLEVEL	RW	Software Level Register
0x010	PRS_CH0_CTRL	RW	Channel Control Register
0x014	PRS_CH1_CTRL	RW	Channel Control Register
0x018	PRS_CH2_CTRL	RW	Channel Control Register
0x01C	PRS_CH3_CTRL	RW	Channel Control Register
0x020	PRS_CH4_CTRL	RW	Channel Control Register
0x024	PRS_CH5_CTRL	RW	Channel Control Register
0x028	PRS_CH6_CTRL	RW	Channel Control Register
0x02C	PRS_CH7_CTRL	RW	Channel Control Register

13.5 Register Description

13.5.1 PRS_SWPULSE - Software Pulse Register

Offset	Bit Position																																																									
	31	30	29	28	27	26	25	24	23	22	21	20	19	18	17	16	15	14	13	12	11	10	9	8	7	6	5	4	3	2	1	0																										
0x000																								0	0	0	0	0	0	0	0	0	0	0	0	0	0	0	0	0	0	0	0	0	0	0	0	0	0	0	0	0	0					
Reset																																																										
Access																								W1	W1	W1	W1	W1	W1	W1	W1	W1	W1	W1	W1	W1	W1	W1	W1	W1	W1	W1	W1	W1	W1	W1	W1	W1	W1	W1	W1	W1	W1	W1				
Name																								CH7PULSE	CH6PULSE	CH5PULSE	CH4PULSE	CH3PULSE	CH2PULSE	CH1PULSE	CH0PULSE																											

Bit	Name	Reset	Access	Description
31:8	Reserved	To ensure compatibility with future devices, always write bits to 0. More information in Section 2.1 (p. 3)		
7	CH7PULSE	0	W1	Channel 7 Pulse Generation See bit 0.
6	CH6PULSE	0	W1	Channel 6 Pulse Generation See bit 0.
5	CH5PULSE	0	W1	Channel 5 Pulse Generation See bit 0.
4	CH4PULSE	0	W1	Channel 4 Pulse Generation See bit 0.
3	CH3PULSE	0	W1	Channel 3 Pulse Generation See bit 0.
2	CH2PULSE	0	W1	Channel 2 Pulse Generation See bit 0.
1	CH1PULSE	0	W1	Channel 1 Pulse Generation See bit 0.
0	CH0PULSE	0	W1	Channel 0 Pulse Generation Write to 1 to generate one HFPERCLK cycle high pulse. This pulse is XOR'ed with the corresponding bit in the SWLEVEL register and the selected PRS input signal to generate the channel output.

Bit	Name	Reset	Access	Description
	Value	Mode		Description
1	POSEDGE			A one HFPERCLK cycle pulse is generated for every positive edge of the incoming signal
2	NEGEDGE			A one HFPERCLK clock cycle pulse is generated for every negative edge of the incoming signal
3	BOTHEDGES			A one HFPERCLK clock cycle pulse is generated for every edge of the incoming signal

23:22 *Reserved* To ensure compatibility with future devices, always write bits to 0. More information in Section 2.1 (p. 3)

21:16 **SOURCESEL** 0x00 RW **Source Select**

Select input source to PRS channel.

Value	Mode	Description
0b000000	NONE	No source selected
0b000001	VCMP	Voltage Comparator
0b000010	ACMP0	Analog Comparator 0
0b000011	ACMP1	Analog Comparator 1
0b000110	DAC0	Digital to Analog Converter 0
0b001000	ADC0	Analog to Digital Converter 0
0b010000	USART0	Universal Synchronous/Asynchronous Receiver/Transmitter 0
0b010001	USART1	Universal Synchronous/Asynchronous Receiver/Transmitter 1
0b010010	USART2	Universal Synchronous/Asynchronous Receiver/Transmitter 2
0b011100	TIMER0	Timer 0
0b011101	TIMER1	Timer 1
0b011110	TIMER2	Timer 2
0b101000	RTC	Real-Time Counter
0b101001	UART0	Universal Asynchronous Receiver/Transmitter 0
0b110000	GPIOL	General purpose Input/Output
0b110001	GPIOH	General purpose Input/Output

15:3 *Reserved* To ensure compatibility with future devices, always write bits to 0. More information in Section 2.1 (p. 3)

2:0 **SIGSEL** 0x0 RW **Signal Select**

Select signal input to PRS channel.

Value	Mode	Description
SOURCESEL = 0b000000 (NONE)		
0bxxx	OFF	Channel input selection is turned off
SOURCESEL = 0b000001 (VCMP)		
0b000	VCMPOUT	Voltage comparator output VCMPOUT
SOURCESEL = 0b000010 (ACMP0)		
0b000	ACMPOUT	Analog comparator output ACMPOUT
SOURCESEL = 0b000011 (ACMP1)		
0b000	ACMP1OUT	Analog comparator output ACMP1OUT
SOURCESEL = 0b000110 (DAC0)		
0b000	DAC0CH0	DAC ch0 conversion done DAC0CH0
0b001	DAC0CH1	DAC ch1 conversion done DAC0CH1
SOURCESEL = 0b001000 (ADC0)		
0b000	ADC0SINGLE	ADC single conversion done ADC0SINGLE
0b001	ADC0SCAN	ADC scan conversion done ADC0SCAN
SOURCESEL = 0b010000 (USART0)		
0b000	USART0IRTX	USART 0 IRDA out USART0IRTX
0b001	USART0TXC	USART 0 TX complete USART0TXC
0b010	USART0RXDATAV	USART 0 RX Data Valid USART0RXDATAV
SOURCESEL = 0b010001 (USART1)		
0b001	USART1TXC	USART 1 TX complete USART1TXC
0b010	USART1RXDATAV	USART 1 RX Data Valid USART1RXDATAV
SOURCESEL = 0b010010 (USART2)		

Bit	Name	Reset	Access	Description
	Value	Mode		Description
	0b001	USART2TXC		USART 2 TX complete USART2TXC
	0b010	USART2RXDATAV		USART 2 RX Data Valid USART2RXDATAV
	SOURCESEL = 0b011100 (TIMER0)			
	0b000	TIMER0UF		Timer 0 Underflow TIMER0UF
	0b001	TIMER0OF		Timer 0 Overflow TIMER0OF
	0b010	TIMER0CC0		Timer 0 Compare/Capture 0 TIMER0CC0
	0b011	TIMER0CC1		Timer 0 Compare/Capture 1 TIMER0CC1
	0b100	TIMER0CC2		Timer 0 Compare/Capture 2 TIMER0CC2
	SOURCESEL = 0b011101 (TIMER1)			
	0b000	TIMER1UF		Timer 1 Underflow TIMER1UF
	0b001	TIMER1OF		Timer 1 Overflow TIMER1OF
	0b010	TIMER1CC0		Timer 1 Compare/Capture 0 TIMER1CC0
	0b011	TIMER1CC1		Timer 1 Compare/Capture 1 TIMER1CC1
	0b100	TIMER1CC2		Timer 1 Compare/Capture 2 TIMER1CC2
	SOURCESEL = 0b011110 (TIMER2)			
	0b000	TIMER2UF		Timer 2 Underflow TIMER2UF
	0b001	TIMER2OF		Timer 2 Overflow TIMER2OF
	0b010	TIMER2CC0		Timer 2 Compare/Capture 0 TIMER2CC0
	0b011	TIMER2CC1		Timer 2 Compare/Capture 1 TIMER2CC1
	0b100	TIMER2CC2		Timer 2 Compare/Capture 2 TIMER2CC2
	SOURCESEL = 0b101000 (RTC)			
	0b000	RTCOF		RTC Overflow RTCOF
	0b001	RTCCOMP0		RTC Compare 0 RTCCOMP0
	0b010	RTCCOMP1		RTC Compare 1 RTCCOMP1
	SOURCESEL = 0b101001 (UART0)			
	0b001	UART0TXC		USART 0 TX complete UART0TXC
	0b010	UART0RXDATAV		USART 0 RX Data Valid UART0RXDATAV
	SOURCESEL = 0b110000 (GPIO)			
	0b000	GPIOPIN0		GPIO pin 0 GPIOPIN0
	0b001	GPIOPIN1		GPIO pin 1 GPIOPIN1
	0b010	GPIOPIN2		GPIO pin 2 GPIOPIN2
	0b011	GPIOPIN3		GPIO pin 3 GPIOPIN3
	0b100	GPIOPIN4		GPIO pin 4 GPIOPIN4
	0b101	GPIOPIN5		GPIO pin 5 GPIOPIN5
	0b110	GPIOPIN6		GPIO pin 6 GPIOPIN6
	0b111	GPIOPIN7		GPIO pin 7 GPIOPIN7
	SOURCESEL = 0b110001 (GPIO)			
	0b000	GPIOPIN8		GPIO pin 8 GPIOPIN8
	0b001	GPIOPIN9		GPIO pin 9 GPIOPIN9
	0b010	GPIOPIN10		GPIO pin 10 GPIOPIN10
	0b011	GPIOPIN11		GPIO pin 11 GPIOPIN11
	0b100	GPIOPIN12		GPIO pin 12 GPIOPIN12
	0b101	GPIOPIN13		GPIO pin 13 GPIOPIN13
	0b110	GPIOPIN14		GPIO pin 14 GPIOPIN14
	0b111	GPIOPIN15		GPIO pin 15 GPIOPIN15

14 EBI - External Bus Interface

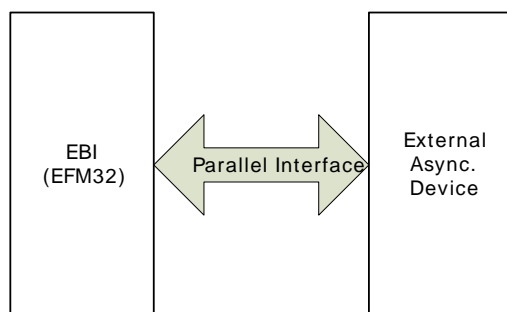
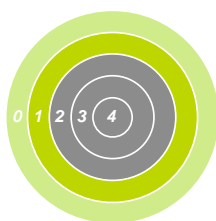

Quick Facts

What?

The EBI is used for accessing external parallel devices. The devices appear as a part of the EFM32G's internal memory map and are therefore extremely simple to use.

Why?

Even though the EFM32G is versatile, there might be a need for specific external devices such as extra RAM, FLASH, LCD. The EBI simplifies the access to such devices.

How?

Through memory mapping the devices appear as a part of the internal memory map. When the processor performs read or writes to the address range of the EBI, the EBI handles the data transfers to and from the external devices. The EBI may be interfaced by the DMA, thus enabling operation in EM1.

14.1 Introduction

The External Bus Interface provides access to external parallel interface devices such as SRAM, FLASH, ADCs and LCDs. The interface is memory mapped into the address bus of the Cortex-M3. This enables seamless access from software without manually manipulating the IO settings each time a read or write is performed. The data and address lines are multiplexed in order to reduce the number of pins required to interface the external devices. The timing is adjustable to meet specifications of the external devices. The interface is limited to asynchronous devices.

14.2 Features

- Programmable interface for various memory types
 - 4 memory bank regions
 - Individual chip select line (EBI_CS_n) per memory bank
 - Accurate control of setup, strobe, hold and turn-around timing
 - Individual active high / active low setting of interface control signals
 - Slave read/write cycle extension
- Multiplexed data and address lines for reduced pin count
 - Up to 24-bit address width
 - Up to 16-bit data width
 - 8-bit true parallel operation

14.3 Functional Description

An overview of the EBI module is shown in Figure 14.1 (p. 135) . The EBI has 16 EBI_AD pin connections which can be used for both address and data. In 8-bit address mode, the address and data both fit into these pins. If more address bits or data bits are needed, external latches can be used to

support up to 24-bit addresses or 16-bit data. When a read operation is requested by the AHB interface, the address is transferred onto the EBI_AD bus. After a specific number of cycles, the EBI_REn pin is activated and data is read from the EBI_AD bus. When a write operation is requested, the address is transferred onto the EBI_AD bus and subsequently the write data is transferred onto the EBI_AD bus as the EBI_WEn pin is activated. The detailed operation in the supported modes is presented in the following sections.

Figure 14.1. EBI Overview

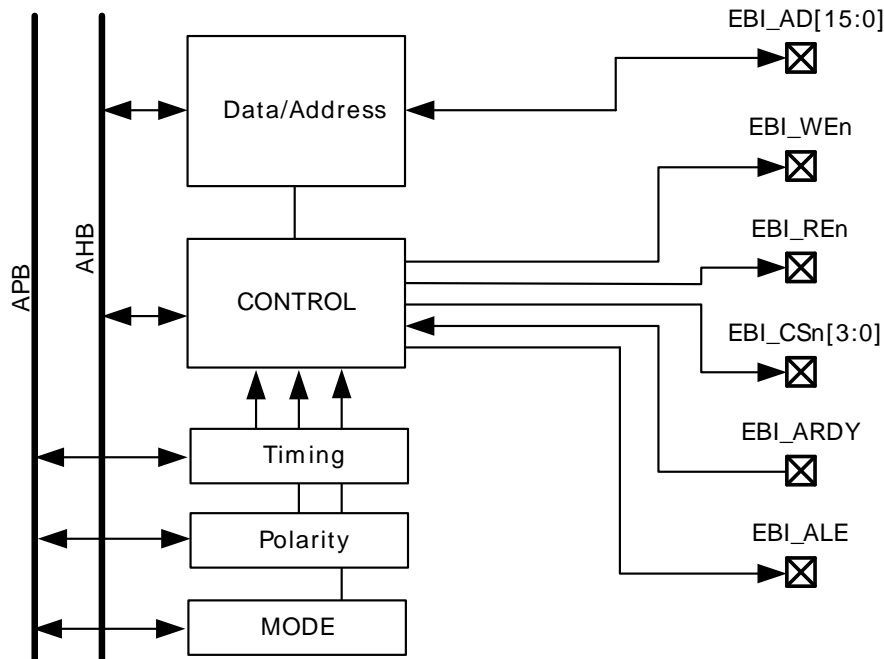

14.3.1 8-bit Address Mode

In this mode, 8-bit address and 8-bit data is supported. The address is put on the higher 8 bits of the EBI_AD lines while the data uses the lower 8 bits. This mode is set by programming the MODE field in the EBI_CTRL register to D8A8. Read and write signals in 8-bit mode are shown in Figure 14.2 (p. 135) and Figure 14.3 (p. 136) respectively.

Figure 14.2. EBI Non-multiplexed 8-bit Data, 8-bit Address Read Operation

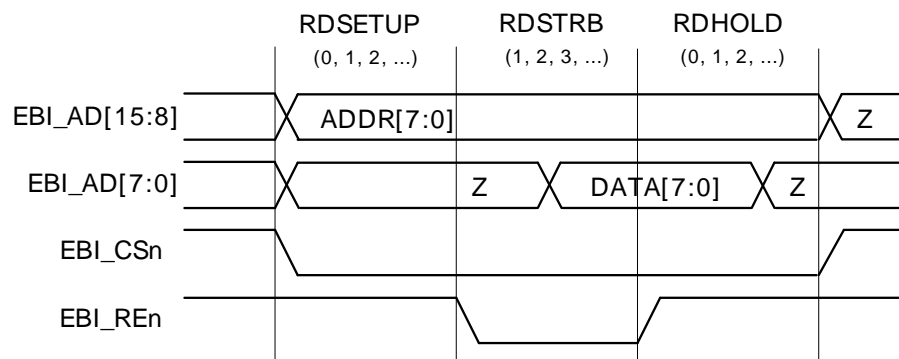
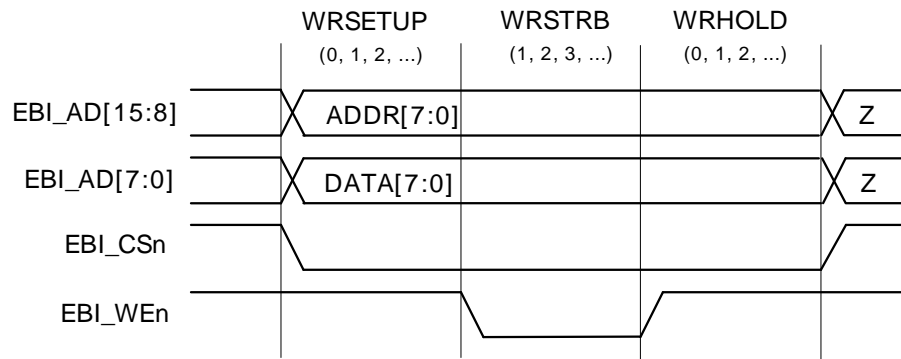

Figure 14.3. EBI Non-multiplexed 8-bit Data, 8-bit Address Write Operation



14.3.2 16-bit Address Mode

In this mode, 16-bit address and 16-bit data is supported, which requires the utilization of a latch. The 16-bit address and 16-bit data bits are multiplexed on the EBI_AD lines. An illustration of such a setup is shown in Figure 14.4 (p. 136). This mode is set by programming the MODE field in the EBI_CTRL register to D16A16ALE.

Note

In this mode the 16-bit address is organized in 2-byte chunks at memory addresses aligned to 2-byte offsets. Consequently, the LSB of the 16-bit address will always be 0. In order to double the address space, the 16-bit address is internally shifted one bit to the right so that the LSB of the address driven into the EBI_AD bus, i.e. the EBI_AD[0]-bit, corresponds to the second least significant bit of the address, i.e. ADDR[1]. At the external device, the LSB of the address must be tied either low or high in order to create a full address.

Figure 14.4. EBI Address Latch Setup

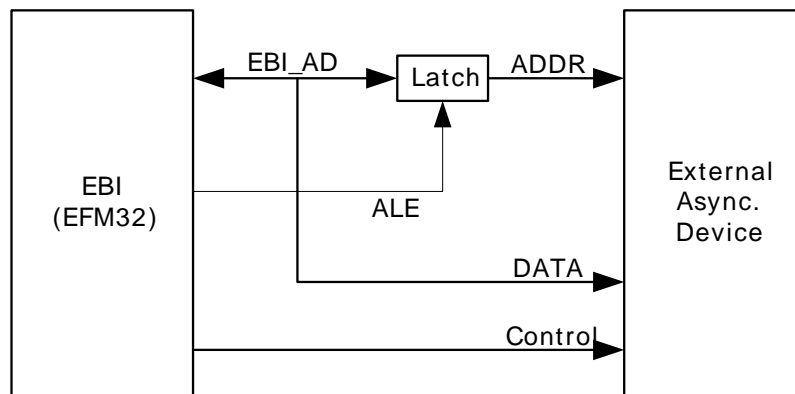

At the start of the transition the address is output on the EBI_AD lines. The Latch is controlled by the ALE (Address Latch Enable) signal and stores the address. Then the data is read or written according to operation. Read and write signals are shown in Figure 14.5 (p. 136) and Figure 14.6 (p. 137) respectively.

Figure 14.5. EBI Multiplexed 16-bit Data, 16-bit Address Read Operation

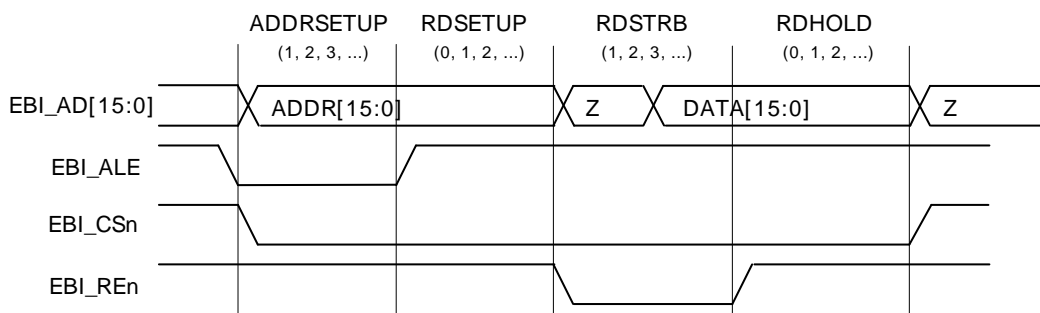
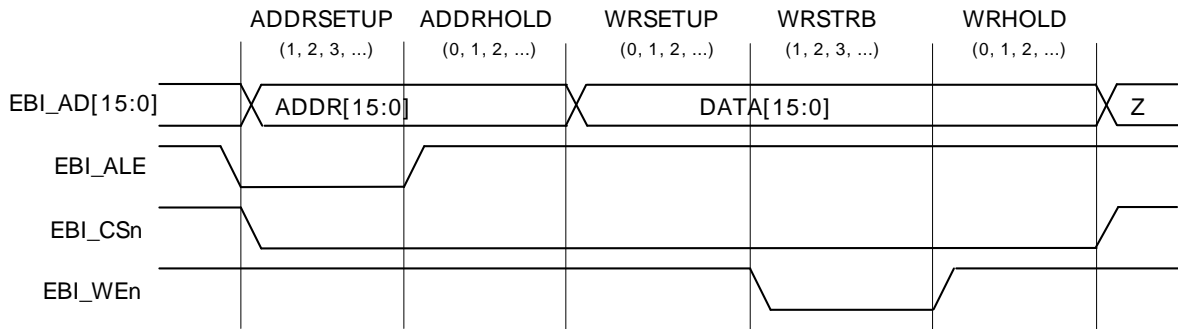

Figure 14.6. EBI Multiplexed 16-bit Data, 16-bit Address Write Operation



14.3.3 24-bit Address Mode

This mode allows 24-bit address with 8-bit data multiplexed on the EBI_AD lines. The upper 8 bits of the EBI_AD lines are consecutively used for the highest 8 bits and the lowest 8 bits of the address. The lower 8 bits of the EBI_AD lines are used for the middle 8 address bits and for data. This mode is set by programming the MODE field in the EBI_CTRL register to D8A24ALE. Read and write signals are shown in Figure 14.7 (p. 137) and Figure 14.8 (p. 137) respectively.

Figure 14.7. EBI Multiplexed 8-bit Data, 24-bit Address Read Operation

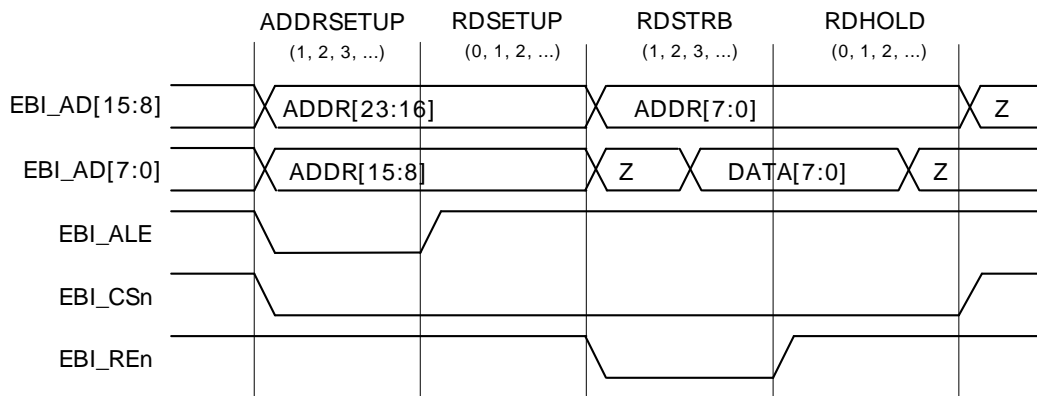
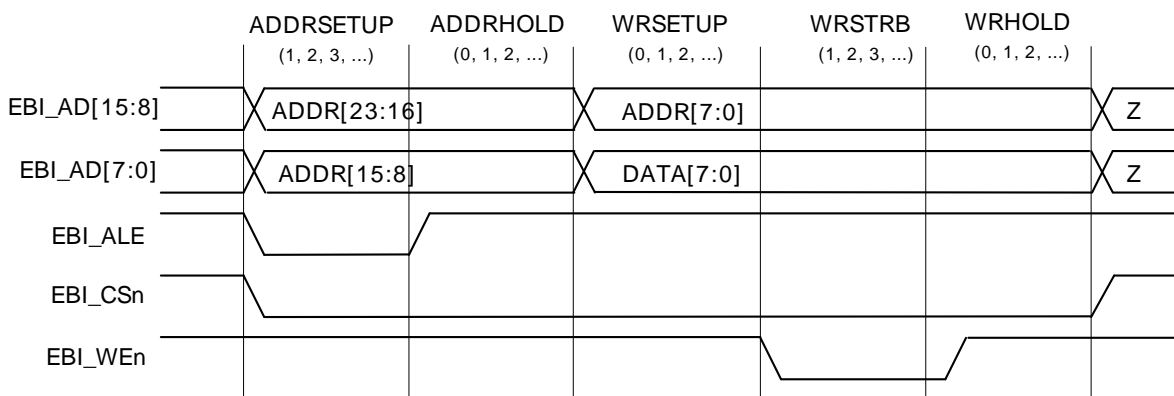

Figure 14.8. EBI Multiplexed 8-bit Data, 24-bit Address Write Operation



14.3.4 Timing

The duration of the states in the transaction is defined by the corresponding uppercase name above the state, e.g. the address setup state in Figure 14.8 (p. 137) is active for a number of internal clock cycles defined by ADDRSET bitfield in the EBI_ADDRTIMING register. Similar timing can be defined by the RDSTRB bitfield in the EBI_RDTIMING register and WRSTRB in the EBI_WRTIMING register. These parameters all have a minimum duration of 1 cycle, which is set by HW, and writing a value n to any of these bitfields results in an extended duration of 1+n cycles.

The setup and hold timing parameters are ADDRHOLD in the EBI_ADDRTIMING register, RDHOLD and RDSETUP in the EBI_RDTIMING register and WRHOLD and WR SETUP in the EBI_WRTIMING register. Writing a value *m* to one of these bitfields results in a duration of the corresponding state of *m* cycles. If these parameters are set to 0, it effectively means that the state is skipped.

Table 14.1 (p. 138) shows typical settings for timing.

Table 14.1. EBI Timing

Reference	Parameter	Min	Typical	Max	Unit
t _{ALS}	Address Setup before ALE high		1		t _{CORE_PERIOD}
t _{ALH}	Address Hold after ALE high		1		t _{CORE_PERIOD}
t _{ALW}	ALE Width		1		t _{CORE_PERIOD}
t _{ARS}	Address Setup before RE high		1		t _{CORE_PERIOD}
t _{ARH}	Address Hold after RE high		1		t _{CORE_PERIOD}
t _{RW}	Data Read Strobe Width		1		t _{CORE_PERIOD}
t _{DRS}	Data Setup before RE high		50		ns
t _{DRH}	Data Hold after RE high	0			ns
t _{AWS}	Address Setup before WE low		1		t _{CORE_PERIOD}
t _{AWH}	Address Hold after WE high		1		t _{CORE_PERIOD}
t _{DWS}	Data Setup before WE high		1		t _{CORE_PERIOD}
t _{DWH}	Data Hold after WE high		1		t _{CORE_PERIOD}
t _{WW}	Data Write Strobe Width		1		t _{CORE_PERIOD}
t _{CH}	Chip Select Hold after WE / RE high		1		t _{CORE_PERIOD}
t _{CRS}	Chip Select Setup to RE low		0		t _{CORE_PERIOD}
t _{CWS}	Chip Select Setup to WE low		1		t _{CORE_PERIOD}

14.3.5 Data Access Width

It is important that the setting of the data width of the external device is respected. If the width of a request does not match the data width specified in the MODE field of the EBI_CTRL register, a bus fault is generated.

14.3.6 Bank Access

The EBI is split in 4 different address regions, each connected to an individual EBI_CS_n line. When accessing one of the memory regions, the corresponding CS_n line is asserted. This way up to 4 separate

devices can share the EBI lines and be identified by the EBI_CS_n line. Each bank can individually be enabled or disabled in the EBI_CTRL register. The bank separation is 64 MB. Refer to the memory map of the EFM32G for a more detailed specification on the memory locations available.

14.3.7 WAIT/ARDY.

Some external devices are able to indicate that they are not finished with either write or read operation by asserting the WAIT / ARDY line. This input signal is used to extend the REn/WEn cycles. The interpretation of the polarity of this signal can be configured with the ARDYPOL bit in EBI_POLARITY. E.g. if the ARDYPOL is set to ACTIVELOW, then the REn/WEn cycle is extended while the ARDY line is kept low. The ARDY functionality is enabled by setting the ARDYEN bit in the EBI_CTRL register. It is also possible to enable a timeout check, which generates a bus error if the ARDY is not deasserted within the timeout period. This prevents a system lock up condition in the case that the external device does not deassert ARDY. The timeout functionality is disabled by setting ARDYTODIS in the EBI_CTRL register.

14.3.8 Control Signal Polarity

It is possible to individually configure the control signals to be active high/low by setting or clearing the appropriate bits in the EBI_POLARITY register.

14.3.9 Pin Configuration

In order to give the EBI access to the external pins of the EFM32G, the GPIO must be configured accordingly. The lines must be set to Push-Pull, which is described in detail in the GPIO section.

All the EBI pins are enabled in the EBI_ROUTE register. The EBI_AD, EBI_WEn and EBI_REn pins are all enabled by the EBIPEN bit, the EBI_CS_n pins are enabled by the corresponding CSxPEN bit, the EBI_ALE pin is enabled by the ALEPEN bit, and the EBI_ARDY pin is enabled by the ARDYPEN bit of the EBI_ROUTE register.

14.4 Register Map

The offset register address is relative to the registers base address.

Offset	Name	Type	Description
0x000	EBI_CTRL	RW	Control Register
0x004	EBI_ADDRTIMING	RW	Address Timing Register
0x008	EBI_RDTIMING	RW	Read Timing Register
0x00C	EBI_WRTIMING	RW	Write Timing Register
0x010	EBI_POLARITY	RW	Polarity Register
0x014	EBI_ROUTE	RW	I/O Routing Register

14.5 Register Description

14.5.1 EBI_CTRL - Control Register

Offset	Bit Position																																						
	31	30	29	28	27	26	25	24	23	22	21	20	19	18	17	16	15	14	13	12	11	10	9	8	7	6	5	4	3	2	1	0							
0x000																	0	0									0	0									0	0	
Reset																	0	0									0	0									0	0	
Access																	RW	RW									RW	RW									RW	RW	
Name																	ARDYTODIS	ARDYEN									BANK3EN	BANK2EN	BANK1EN	BANK0EN									MODE

Bit	Name	Reset	Access	Description
31:18	<i>Reserved</i>	<i>To ensure compatibility with future devices, always write bits to 0. More information in Section 2.1 (p. 3)</i>		
17	ARDYTODIS	0	RW	ARDY Timeout Disable Enables or disables the ARDY timeout functionality. The timeout value is 32 internal clock cycles.
16	ARDYEN	0	RW	ARDY Enable Enables or disables the ARDY functionality.
15:12	<i>Reserved</i>	<i>To ensure compatibility with future devices, always write bits to 0. More information in Section 2.1 (p. 3)</i>		
11	BANK3EN	0	RW	Bank 3 Enable This field enables or disables bank 3.
10	BANK2EN	0	RW	Bank 2 Enable This field enables or disables bank 2.
9	BANK1EN	0	RW	Bank 1 Enable This field enables or disables bank 1.
8	BANK0EN	0	RW	Bank 0 Enable This field enables or disables bank 0.
7:2	<i>Reserved</i>	<i>To ensure compatibility with future devices, always write bits to 0. More information in Section 2.1 (p. 3)</i>		
1:0	MODE	0x0	RW	Mode This field sets the access mode the EBI will use for interfacing devices.

Value	Mode	Description
0	D8A8	8 bit data, 8 bit address, ALE not used.
1	D16A16ALE	16 bit data, 16 bit address, ALE is used for address latching.
2	D8A24ALE	8 bit data, 24 bit address, ALE is used for address latching.

14.5.2 EBI_ADDRTIMING - Address Timing Register

Offset	Bit Position																																						
0x004	31	30	29	28	27	26	25	24	23	22	21	20	19	18	17	16	15	14	13	12	11	10	9	8	7	6	5	4	3	2	1	0							
Reset																								0x1														0x0	
Access																								RW														RW	
Name																								ADDRHOLD														ADDRSETUP	

Bit	Name	Reset	Access	Description
31:10	Reserved	<i>To ensure compatibility with future devices, always write bits to 0. More information in Section 2.1 (p. 3)</i>		
9:8	ADDRHOLD	0x1	RW	Address Hold Time Sets the number of cycles the address is held after ALE is asserted.
7:2	Reserved	<i>To ensure compatibility with future devices, always write bits to 0. More information in Section 2.1 (p. 3)</i>		
1:0	ADDRSETUP	0x0	RW	Address Setup Time Sets the number of cycles the address is driven onto the ADDRDAT bus before ALE is asserted. If set to 0, 1 cycle is inserted by HW.

14.5.3 EBI_RDTIMING - Read Timing Register

Offset	Bit Position																																			
0x008	31	30	29	28	27	26	25	24	23	22	21	20	19	18	17	16	15	14	13	12	11	10	9	8	7	6	5	4	3	2	1	0				
Reset																	0x0																0x0			
Access																	RW																RW			
Name																	RDHOLD																RDSTRB		RDSETUP	

Bit	Name	Reset	Access	Description
31:18	Reserved	<i>To ensure compatibility with future devices, always write bits to 0. More information in Section 2.1 (p. 3)</i>		
17:16	RDHOLD	0x0	RW	Read Hold Time Sets the number of cycles CSn is held active after the REN is deasserted. This interval is used for bus turnaround.
15:12	Reserved	<i>To ensure compatibility with future devices, always write bits to 0. More information in Section 2.1 (p. 3)</i>		
11:8	RDSTRB	0x0	RW	Read Strobe Time Sets the number of cycles the REN is held active. After the specified number of cycles, data is read. If set to 0, 1 cycle is inserted by HW.
7:2	Reserved	<i>To ensure compatibility with future devices, always write bits to 0. More information in Section 2.1 (p. 3)</i>		
1:0	RDSETUP	0x0	RW	Read Setup Time Sets the number of cycles the address setup before REN is asserted.

14.5.4 EBI_WRTIMING - Write Timing Register

Offset	Bit Position																																	
0x00C	31	30	29	28	27	26	25	24	23	22	21	20	19	18	17	16	15	14	13	12	11	10	9	8	7	6	5	4	3	2	1	0		
Reset																0x1											0x0							0x0
Access																RW											RW							RW
Name																WRHOLD											WRSTRB							WRSETUP

Bit	Name	Reset	Access	Description
31:18	Reserved	To ensure compatibility with future devices, always write bits to 0. More information in Section 2.1 (p. 3)		
17:16	WRHOLD	0x1	RW	Write Hold Time Sets the number of cycles CSn is held active after the WEn is deasserted.
15:12	Reserved	To ensure compatibility with future devices, always write bits to 0. More information in Section 2.1 (p. 3)		
11:8	WRSTRB	0x0	RW	Write Strobe Time Sets the number of cycles the WEn is held active. If set to 0, 1 cycle is inserted by HW.
7:2	Reserved	To ensure compatibility with future devices, always write bits to 0. More information in Section 2.1 (p. 3)		
1:0	WRSETUP	0x0	RW	Write Setup Time Sets the number of cycles the address setup before WEn is asserted.

14.5.5 EBI_POLARITY - Polarity Register

Offset	Bit Position																																		
0x010	31	30	29	28	27	26	25	24	23	22	21	20	19	18	17	16	15	14	13	12	11	10	9	8	7	6	5	4	3	2	1	0			
Reset																															0	0	0	0	0
Access																															RW	RW	RW	RW	RW
Name																															ARDYPOL	ALEPOL	WEPOL	REPOL	CSPOL

Bit	Name	Reset	Access	Description									
31:5	Reserved	To ensure compatibility with future devices, always write bits to 0. More information in Section 2.1 (p. 3)											
4	ARDYPOL	0	RW	ARDY Polarity Sets the polarity of the EBI_ARDY line. <table border="1" style="width: 100%; border-collapse: collapse;"> <thead> <tr> <th>Value</th> <th>Mode</th> <th>Description</th> </tr> </thead> <tbody> <tr> <td>0</td> <td>ACTIVELOW</td> <td>ARDY is active low.</td> </tr> <tr> <td>1</td> <td>ACTIVEHIGH</td> <td>ARDY is active high.</td> </tr> </tbody> </table>	Value	Mode	Description	0	ACTIVELOW	ARDY is active low.	1	ACTIVEHIGH	ARDY is active high.
Value	Mode	Description											
0	ACTIVELOW	ARDY is active low.											
1	ACTIVEHIGH	ARDY is active high.											
3	ALEPOL	0	RW	Address Latch Polarity Sets the polarity of the EBI_ALE line. <table border="1" style="width: 100%; border-collapse: collapse;"> <thead> <tr> <th>Value</th> <th>Mode</th> <th>Description</th> </tr> </thead> <tbody> <tr> <td>0</td> <td>ACTIVELOW</td> <td>ALE is active low.</td> </tr> <tr> <td>1</td> <td>ACTIVEHIGH</td> <td>ALE is active high.</td> </tr> </tbody> </table>	Value	Mode	Description	0	ACTIVELOW	ALE is active low.	1	ACTIVEHIGH	ALE is active high.
Value	Mode	Description											
0	ACTIVELOW	ALE is active low.											
1	ACTIVEHIGH	ALE is active high.											
2	WEPOL	0	RW	Write Enable Polarity Sets the polarity of the EBI_WEn line.									

Bit	Name	Reset	Access	Description
	Value	Mode		Description
	0	ACTIVELOW		WEn is active low.
	1	ACTIVEHIGH		WEn is active high.
1	REPOL	0	RW	Read Enable Polarity Sets the polarity of the EBI_REn line.
	Value	Mode		Description
	0	ACTIVELOW		REn is active low.
	1	ACTIVEHIGH		REn is active high.
0	CSPOL	0	RW	Chip Select Polarity Sets the polarity of the EBI_CSn line.
	Value	Mode		Description
	0	ACTIVELOW		CSn is active low.
	1	ACTIVEHIGH		CSn is active high.

14.5.6 EBI_ROUTE - I/O Routing Register

Offset	Bit Position																															
0x014	31	30	29	28	27	26	25	24	23	22	21	20	19	18	17	16	15	14	13	12	11	10	9	8	7	6	5	4	3	2	1	0
Reset																									0	0	0	0	0	0	0	
Access																									RW	RW	RW	RW	RW	RW	RW	
Name																									ARDYPEN	ALEPEN	CS3PEN	CS2PEN	CS1PEN	CS0PEN	EBIPEN	

Bit	Name	Reset	Access	Description
31:7	Reserved	<i>To ensure compatibility with future devices, always write bits to 0. More information in Section 2.1 (p. 3)</i>		
6	ARDYPEN	0	RW	EBI_ARDY Pin Enable When set, the EBI_ARDY pin is enabled
5	ALEPEN	0	RW	EBI_ALE Pin Enable When set, the EBI_ALE pin is enabled
4	CS3PEN	0	RW	EBI_CS3 Pin Enable When set, the EBI_CS3 pin is enabled
3	CS2PEN	0	RW	EBI_CS2 Pin Enable When set, the EBI_CS2 pin is enabled
2	CS1PEN	0	RW	EBI_CS1 Pin Enable When set, the EBI_CS1 pin is enabled
1	CS0PEN	0	RW	EBI_CS0 Pin Enable When set, the EBI_CS0 pin is enabled
0	EBIPEN	0	RW	EBI Pin Enable When set, the EBI_AD[15:0], EBI_WEn and EBI_REn pins are enabled

15 I²C - Inter-Integrated Circuit Interface

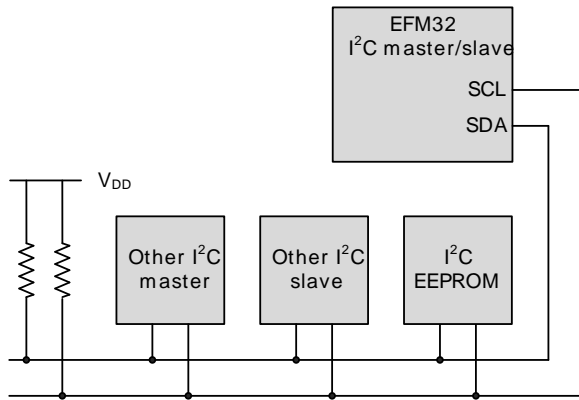
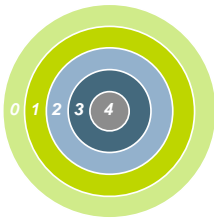

Quick Facts

What?

The I²C interface allows communication on I²C-buses with the lowest energy consumption possible.

Why?

I²C is a popular serial bus that enables communication with a number of external devices using only two I/O pins.

How?

With the help of DMA, the I²C interface allows I²C communication with minimal CPU intervention. Address recognition is available in all energy modes (except EM4), allowing the MCU to wait for data on the I²C-bus with sub- μ A current consumption.

15.1 Introduction

The I²C module provides an interface between the MCU and a serial I²C-bus. It is capable of acting as both a master and a slave, and supports multi-master buses. Both standard-mode, fast-mode and fast-mode plus speeds are supported, allowing transmission rates all the way from 10 kbit/s up to 1 Mbit/s. Slave arbitration and timeouts are also provided to allow implementation of an SMBus compliant system. The interface provided to software by the I²C module, allows both fine-grained control of the transmission process and close to automatic transfers. Automatic recognition of slave addresses is provided in all energy modes.

15.2 Features

- True multi-master capability
- Support for different bus speeds
 - Standard-mode (Sm) bitrate up to 100 kbit/s
 - Fast-mode (Fm) bitrate up to 400 kbit/s
 - Fast-mode Plus (Fm+) bitrate up to 1 Mbit/s
- Arbitration for both master and slave (Allows SMBus ARP)
- Clock synchronization and clock stretching
- Hardware address recognition
 - 7-bit masked address
 - General call address
 - Active in all energy modes
- 10-bit address support
- Error handling
 - Clock low timeout
 - Clock high timeout
 - Arbitration lost
 - Bus error detection
- Double buffered data
- Full DMA support

15.3 Functional Description

An overview of the I²C module is shown in Figure 15.1 (p. 145) .

Figure 15.1. I²C Overview

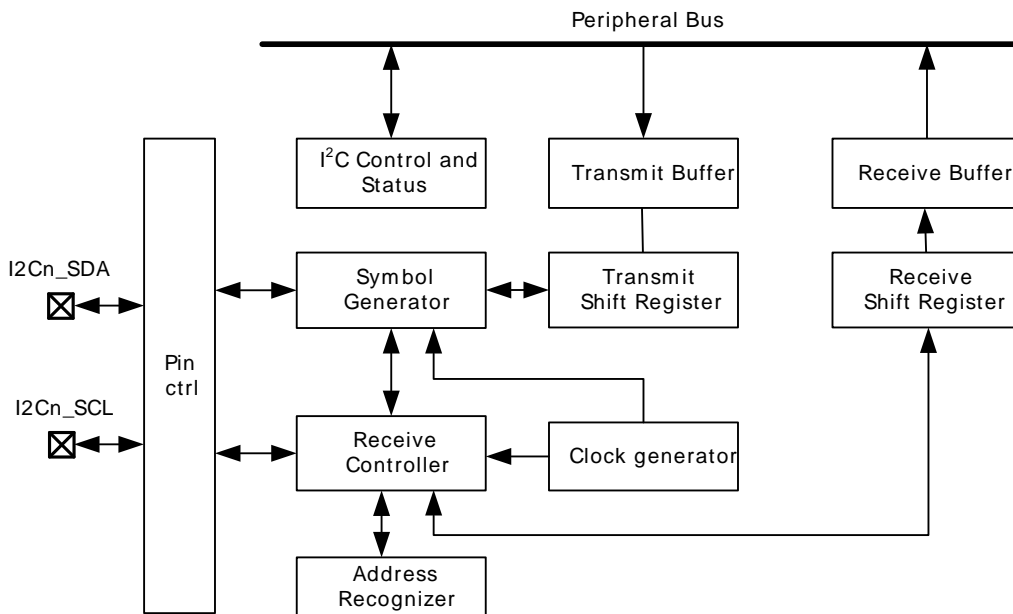

15.3.1 I²C-Bus Overview

The I²C-bus uses two wires for communication; a serial data line (SDA) and a serial clock line (SCL) as show in Figure 15.2 (p. 145) . As a true multi-master bus it includes collision detection and arbitration to resolve situations where multiple masters transmit data at the same time without data loss.

Figure 15.2. I²C-Bus Example

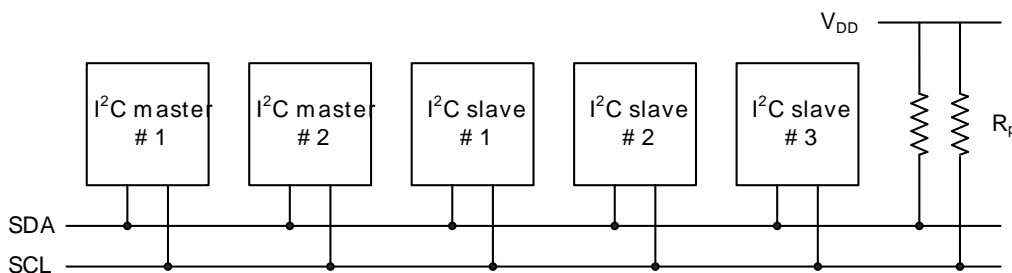

Each device on the bus is addressable by a unique address, and an I²C master can address all the devices on the bus, including other masters.

Both the bus lines are open-drain. The maximum value of the pull-up resistor can be calculated as a function of the maximal rise-time t_r for the given bus speed, and the estimated bus capacitance C_b as shown in Equation 15.1 (p. 145) .

I²C Pull-up Resistor Equation

$$R_p(\text{max}) = t_r / 0.8473 \times C_b \tag{15.1}$$

The maximal rise times for 100 kHz, 400 kHz and 1 MHz I²C are 1 μ s, 300 ns and 120 ns respectively.

Note

The GPIO drive strength can be used to control slew rate.

Note

If V_{dd} drops below voltage on SCL and SDA lines, the MCU could become back powered and pull the SCL and SDA lines low.

15.3.1.1 START and STOP Conditions

START and STOP conditions are used to initiate and stop transactions on the I²C-bus. All transactions on the bus begin with a START condition (S) and end with a STOP condition (P). As shown in Figure 15.3 (p. 146), a START condition is generated by pulling the SDA line low while SCL is high, and a STOP condition is generated by pulling the SDA line high while SCL is high.

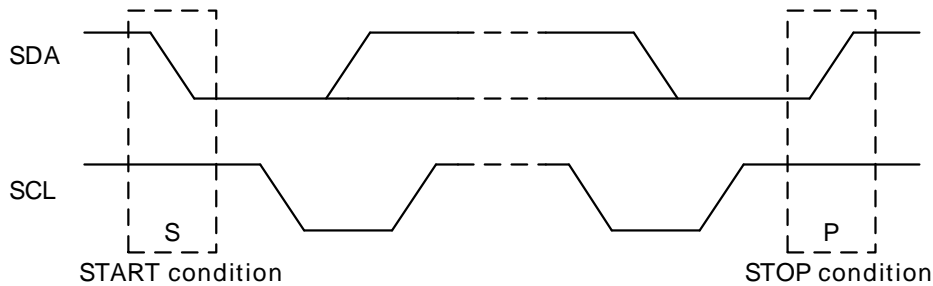
Figure 15.3. I²C START and STOP Conditions

The START and STOP conditions are easily identifiable bus events as they are the only conditions on the bus where a transition is allowed on SDA while SCL is high. During the actual data transmission, SDA is only allowed to change while SCL is low, and must be stable while SCL is high. One bit is transferred per clock pulse on the I²C-bus as shown in Figure 15.2 (p. 145).

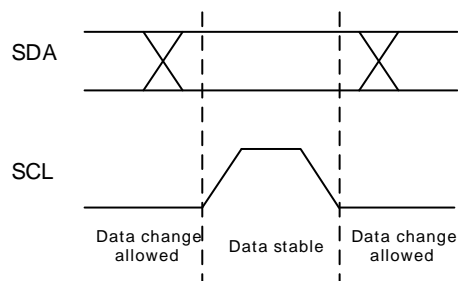
Figure 15.4. I²C Bit Transfer on I²C-Bus**15.3.1.2 Bus Transfer**

When a master wants to initiate a transfer on the bus, it waits until the bus is idle and transmits a START condition on the bus. The master then transmits the address of the slave it wishes to interact with and a single R/W bit telling whether it wishes to read from the slave (R/W bit set to 1) or write to the slave (R/W bit set to 0).

After the 7-bit address and the R/W bit, the master releases the bus, allowing the slave to acknowledge the request. During the next bit-period, the slave pulls SDA low (ACK) if it acknowledges the request, or keeps it high if it does not acknowledge it (NACK).

Following the address acknowledge, either the slave or master transmits data, depending on the value of the R/W bit. After every 8-bit byte transmitted on the SDA line, the transmitter releases the line to allow the receiver to transmit an ACK or a NACK. Both the data and the address are transmitted with the most significant bit first.

The number of bytes in a bus transfer is unrestricted. The master ends the transmission after a (N)ACK by sending a STOP condition on the bus. After a STOP condition, any master wishing to initiate a transfer on the bus can try to gain control of it. If the current master wishes to make another transfer immediately

after the current, it can start a new transfer directly by transmitting a repeated START condition (Sr) instead of a STOP followed by a START.

Examples of I²C transfers are shown in Figure 15.5 (p. 147), Figure 15.6 (p. 147), and Figure 15.7 (p. 147) . The identifiers used are:

- ADDR - Address
- DATA - Data
- S - Start bit
- Sr - Repeated start bit
- P - Stop bit
- W/R - Read(1)/Write(0)
- A - ACK
- N - NACK

Figure 15.5. I²C Single Byte Write to Slave

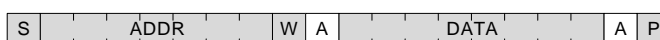
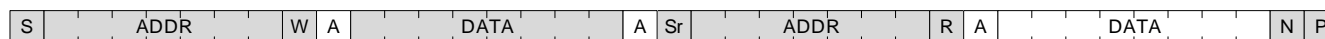

Figure 15.6. I²C Double Byte Read from Slave



Figure 15.7. I²C Single Byte Write, then Repeated Start and Single Byte Read



15.3.1.3 Addresses

I²C supports both 7-bit and 10-bit addresses. When using 7-bit addresses, the first byte transmitted after the START-condition contains the address of the slave the master wants to contact. In the 7-bit address space, several addresses are reserved. These addresses are summarized in Table 15.1 (p. 147) , and include a General Call address which can be used to broadcast a message to all slaves on the I²C-bus.

Table 15.1. I²C Reserved I²C Addresses

I ² C Address	R/W	Description
0000-000	0	General Call address
0000-000	1	START byte
0000-001	X	Reserved for the C-Bus format
0000-010	X	Reserved for a different bus format
0000-011	X	Reserved for future purposes
0000-1XX	X	Reserved for future purposes
1111-1XX	X	Reserved for future purposes
1111-0XX	X	10 Bit slave addressing mode

15.3.1.4 10-bit Addressing

To address a slave using a 10-bit address, two bytes are required to specify the address instead of one. The seven first bits of the first byte must then be 1111 0XX, where XX are the two most significant bits of the 10-bit address. As with 7-bit addresses, the eighth bit of the first byte determines whether the master wishes to read from or write to the slave. The second byte contains the eight least significant bits of the slave address.

When a slave receives a 10-bit address, it must acknowledge both the address bytes if they match the address of the slave.

When performing a master transmitter operation, the master transmits the two address bytes and then the remaining data, as shown in Figure 15.8 (p. 148) .

Figure 15.8. I²C Master Transmitter/Slave Receiver with 10-bit Address

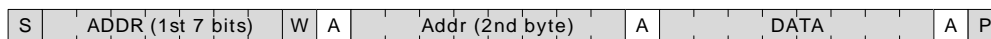

When performing a master receiver operation however, the master first transmits the two address bytes in a master transmitter operation, then sends a repeated START followed by the first address byte and then receives data from the addressed slave. The slave addressed by the 10-bit address in the first two address bytes must remember that it was addressed, and respond with data if the address transmitted after the repeated start matches its own address. An example of this, with one byte transmitted is shown in Figure 15.9 (p. 148) .

Figure 15.9. I²C Master Receiver/Slave Transmitter with 10-bit Address

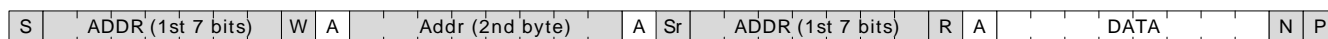

15.3.1.5 Arbitration, Clock Synchronization, Clock Stretching

Arbitration and clock synchronization are features aimed at allowing multi-master buses. Arbitration occurs when two devices try to drive the bus at the same time. If one device drives it low, while the other drives it high, the one attempting to drive it high will not be able to do so due to the open-drain bus configuration. Both devices sample the bus, and the one that was unable to drive the bus in the desired direction detects the collision and backs off, letting the other device continue communication on the bus undisturbed.

Clock synchronization is a means of synchronizing the clock outputs from several masters driving the bus at once, and is a requirement for effective arbitration.

Slaves on the bus are allowed to force the clock output on the bus low in order to pause the communication on the bus and give themselves time to process data or perform any real-time tasks they might have. This is called clock stretching.

Arbitration is supported by the I²C module for both masters and slaves. Clock synchronization and clock stretching is also supported.

15.3.2 Enable and Reset

The I²C is enabled by setting the EN bit in the I2Cn_CTRL register. Whenever this bit is cleared, the internal state of the I²C is reset, terminating any ongoing transfers.

Note

When Re-enabling the I²C, the ABORT command or the Bus Idle Timeout feature must be applied prior to use even if the BUSY flag is not set.

15.3.3 Safely disabling and changing slave configuration

The I²C slave is partially asynchronous, and some precautions may be necessary to always ensure a safe slave disable or configuration change. If the user cannot guarantee that an address match will not occur at the exact time of slave disable or slave configuration change while the slave is enabled, these measures should be made.

Worst case consequences for an address match while disabling slave or changing configuration is that the slave may end up in an undefined state. To reset the slave back to a known state, the EN bit in

I2Cn_CTRL must be reset. This should be done regardless whether the slave is going to be re-enabled or not.

15.3.4 Clock Generation

The SCL clock signal generated by the I²C master determines maximum transmission rate on the bus. The clock is generated as a division of the peripheral clock, and is given by Equation 15.2 (p. 149) :

I²C Maximum Transmission Rate

$$f_{SCL} = f_{HFPERCLK} / (((N_{low} + N_{high}) \times (DIV + 1)) + 4) \quad (15.2)$$

N_{low} and N_{high} specify the number of prescaled clock cycles in the low and high periods of the clock signal respectively. The worst case low and high periods of the signal are:

I²C High and Low Cycles Equations

$$\begin{aligned} T_{high} &= (N_{high} \times (DIV + 1) + 3) / f_{HFPERCLK} \\ T_{low} &= (N_{low} \times (DIV + 1) + 3) / f_{HFPERCLK} \end{aligned} \quad (15.3)$$

The values of N_{low} and N_{high} and thus the ratio between the high and low parts of the clock signal is controlled by CLHR in the I2Cn_CTRL register. The available modes are summarized in Table 15.2 (p. 149) along with the highest I²C-bus frequencies in the given modes that can be achieved without violating the timing specifications of the I²C-bus. The frequencies are calculated taking the maximum allowed rise and fall times of SDA and SCL into account. Higher frequencies may be achieved in practice. The 3 extra cycles are synchronization, and must be taken into consideration when DIV in the I2Cn_CLKDIV register has a low value.

Note

DIV must be 1 or higher when slave is enabled.

Table 15.2. I²C Clock Modes

Mode	CLHR	N _{low} : N _{high}	Sm max frequency	Fm max frequency	Fm+ max frequency
STANDARD	0	4:4	93 kHz	313 kHz	806 kHz
ASYMMETRIC	1	6:3	75 kHz	392 kHz	980 kHz
FAST	2	11:6	79 kHz	383 kHz	987 kHz

15.3.5 Arbitration

Arbitration is enabled by default, but can be disabled by setting the ARBDIS bit in I2Cn_CTRL. When arbitration is enabled, the value on SDA is sensed after each time the I²C module attempts to change its value. If the sensed value is different than the value the I²C module tried to output, it is interpreted as a simultaneous transmission by another device, and the I²C module has lost arbitration.

Whenever arbitration is lost, the ARBLOST interrupt flag in I2Cn_IF is set, any lines held are released, and the I²C device goes idle. If an I²C master loses arbitration during the transmission of an address, another master may be trying to address it. The master therefore receives the rest of the address, and if the address matches the slave address of the master, the master goes into either slave transmitter or slave receiver mode.

Note

Arbitration can be lost both when operating as a master and when operating as a slave.

15.3.6 Buffers

15.3.6.1 Transmit Buffer and Shift Register

The I²C transmitter is double buffered through the transmit buffer and transmit shift register as shown in Figure 15.1 (p. 145). A byte is loaded into the transmit buffer by writing to I2Cn_TXDATA. When the transmit shift register is empty and ready for new data, a byte from the transmit buffer is loaded into the shift register if available. The byte is then kept in the shift register until it is transmitted. When a byte has been transmitted, a new byte is loaded into the shift register if available. If the transmit buffer is empty, the shift register remains empty, and the TXC flag in I2Cn_STATUS and the TXC interrupt flags in I2Cn_IF are set, signaling that the shift register transmitter is out of data. TXC is cleared when new data becomes available, but the TXC interrupt flag must be cleared by software.

Whenever a byte is loaded from the transmit buffer to the transmit shift register, the TXBL flag in I2Cn_STATUS and the TXBL interrupt flag in I2Cn_IF are set, indicating that there is room in the buffer for more data. TXBL is cleared automatically when data is written to the buffer.

If a write is attempted to the transmit buffer while it is not empty, the TXOF interrupt flag in I2Cn_IF is set, indicating the overflow. The data already in the buffer is in that case preserved, and no data is written.

The transmit buffer, including the transmit shift register can be cleared by setting command bit CLEAR_TX in I2Cn_CMD. This will prevent the I²C module from transmitting the data in the buffer and shift register, and will make them available for new data. Any byte currently being transmitted will not be aborted. Transmission of this byte will be completed.

15.3.6.2 Receive Buffer and Shift Register

Like the transmitter, the I²C receiver is double buffered. The receiver uses the receive buffer and receive shift register as shown in Figure 15.1 (p. 145). When a byte has been fully received by the receive shift register, it is loaded into the receive buffer if there is room for it. Else, the byte waits in the shift register until space is available in the buffer.

When a byte becomes available in the receive buffer, the RXDATAV in I2Cn_STATUS and RXDATAV interrupt flag in I2Cn_IF are set, and the data can be fetched from the buffer using I2Cn_RXDATA. Reading from this register will pull a byte out of the buffer, making room for a new byte and clearing RXDATAV in I2Cn_STATUS and RXDATAV in I2Cn_IF in the process.

If a read from the receive buffer is attempted through I2Cn_RXDATA while the buffer is empty, the RXUF interrupt flag in I2Cn_IF is set, and the data read from the buffer is undefined.

I2Cn_RXDATAP can be used to read data from the receive buffer without removing it from the buffer. The RXUF interrupt flag in I2Cn_IF will never be set as a result of reading from I2Cn_RXDATAP, but the data read through I2Cn_RXDATAP when the receive buffer is empty is still undefined.

15.3.7 Master Operation

A bus transaction is initiated by transmitting a START condition (S) on the bus. This is done by setting the START bit in I2Cn_CMD. The command schedules a START condition, and makes the I²C module generate a start condition whenever the bus becomes free.

The I²C-bus is considered busy whenever another device on the bus transmits a START condition. Until a STOP condition is detected, the bus is owned by the master issuing the START condition. The bus is considered free when a STOP condition is transmitted on the bus. After a STOP is detected, all masters that have data to transmit send a START condition and begin transmitting data. Arbitration ensures collisions are avoided.

When the START condition has been transmitted, the master must transmit a slave address (ADDR) with an R/W bit on the bus. If this address is available in the transmit buffer, the master transmits it immediately, but if the buffer is empty, the master holds the I²C-bus while waiting for software to write the address to the transmit buffer.

After the address has been transmitted, a sequence of bytes can be read from or written to the slave, depending on the value of the R/W bit (bit 0 in the address byte). If the bit was cleared, the master has entered a master transmitter role, where it now transmits data to the slave. If the bit was set, it has entered a master receiver role, where it now should receive data from the slave. In either case, an unlimited number of bytes can be transferred in one direction during the transmission.

At the end of the transmission, the master either transmits a repeated START condition (Sr) if it wishes to continue with another transfer, or transmits a STOP condition (P) if it wishes to release the bus.

15.3.7.1 Master State Machine

The master state machine is shown in Figure 15.10 (p. 151). A master operation starts in the far left of the state machine, and follows the solid lines through the state machine, ending the operation or continuing with a new operation when arriving at the right side of the state machine.

Branches in the path through the state machine are the results of bus events and choices made by software, either directly or indirectly. The dotted lines show where I²C-specific interrupt flags are set along the path and the full-drawn circles show places where interaction may be required by software to let the transmission proceed.

Figure 15.10. I²C Master State Machine

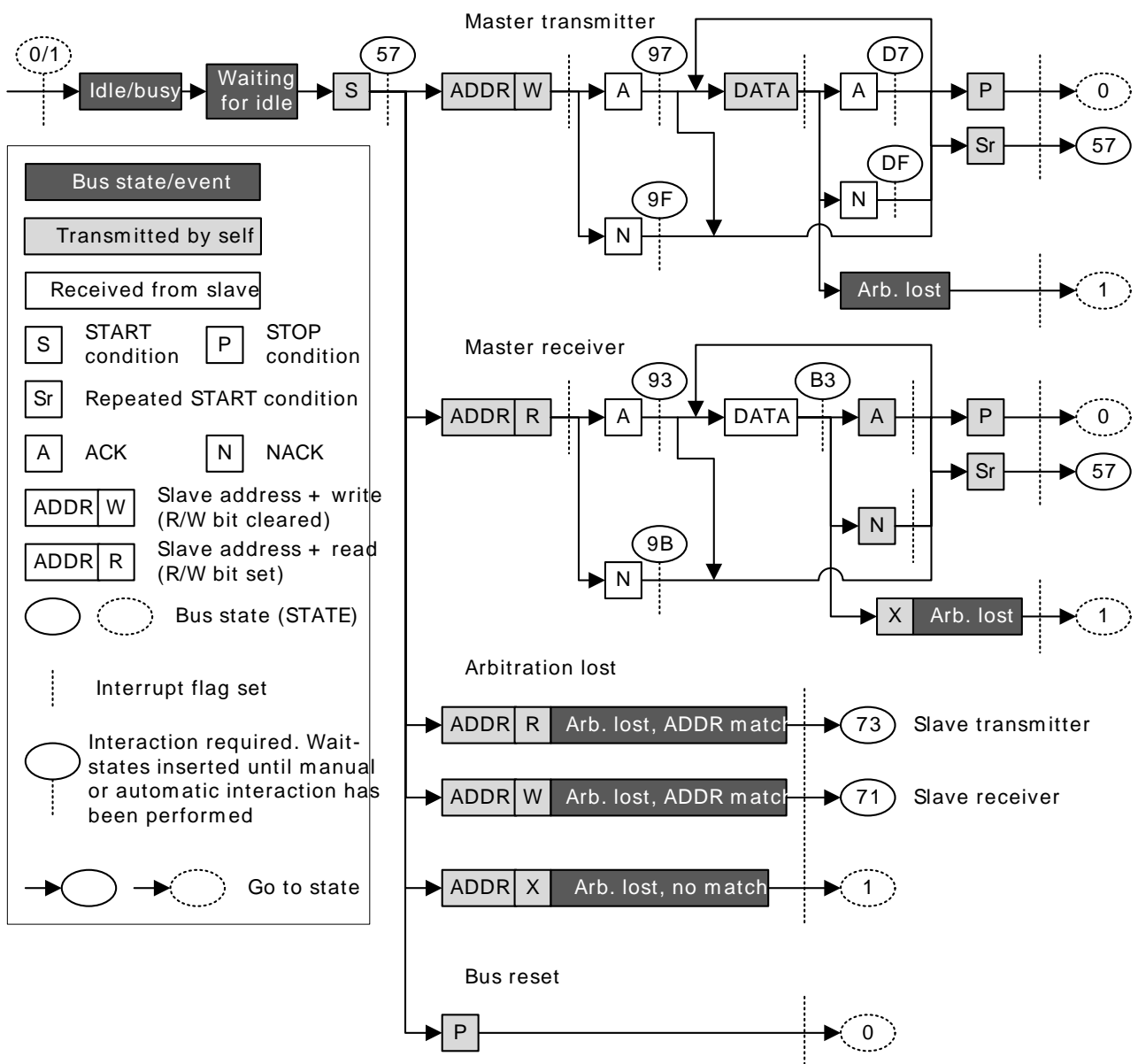

15.3.7.2 Interactions

Whenever the I²C module is waiting for interaction from software, it holds the bus clock SCL low, freezing all bus activities, and the BUSHOLD interrupt flag in I2Cn_IF is set. The action(s) required by software depends on the current state the of the I²C module. This state can be read from the I2Cn_STATE register.

As an example, Table 15.4 (p. 154) shows the different states the I²C goes through when operating as a Master Transmitter, i.e. a master that transmits data to a slave. As seen in the table, when a start condition has been transmitted, a requirement is that there is an address and an R/W bit in the transmit buffer. If the transmit buffer is empty, then the BUSHOLD interrupt flag is set, and the bus is held until data becomes available in the buffer. While waiting for the address, I2Cn_STATE has a value 0x57, which can be used to identify exactly what the I²C module is waiting for.

Note

The bus would never stop at state 0x57 if the address was available in the transmit buffer.

The different interactions used by the I²C module are listed in Table 15.3 (p. 152) in prioritized order. If a set of different courses of action are possible from a given state, the course of action using the highest priority interactions, that first has everything it is waiting for is the one that is taken.

Table 15.3. I²C Interactions in Prioritized Order

Interaction	Priority	Software action	Automatically continues if
STOP*	1	Set the STOP command bit in I2Cn_CMD	PSTOP is set (STOP pending) in I2Cn_STATUS
ABORT	2	Set the ABORT command bit in I2Cn_CMD	Never, the transmission is aborted
CONT*	3	Set the CONT command bit in I2Cn_CMD	PCONT is set in I2Cn_STATUS (CONT pending)
NACK*	4	Set the NACK command bit in I2Cn_CMD	PNACK is set in I2Cn_STATUS (NACK pending)
ACK*	5	Set the ACK command bit in I2Cn_CMD	AUTOACK is set in I2Cn_CTRL or PACK is set in I2Cn_STATUS (ACK pending)
ADDR+W -> TXDATA	6	Write an address to the transmit buffer with the R/W bit set	Address is available in transmit buffer with R/W bit set
ADDR+R -> TXDATA	7	Write an address to the transmit buffer with the R/W bit cleared	Address is available in transmit buffer with R/W bit cleared
START*	8	Set the START command bit in I2Cn_CMD	PSTART is set in I2Cn_STATUS (START pending)
TXDATA	9	Write data to the transmit buffer	Data is available in transmit buffer
RXDATA	10	Read data from receive buffer	Space is available in receive buffer
None	11	No interaction is required	

The commands marked with a * in Table 15.3 (p. 152) can be issued before an interaction is required. When such a command is issued before it can be used/consumed by the I²C module, the command is

set in a pending state, which can be read from the STATUS register. A pending START command can for instance be identified by PSTART having a high value.

Whenever the I²C module requires an interaction, it checks the pending commands. If one or a combination of these can fulfill an interaction, they are consumed by the module and the transmission continues without setting the BUSHOLD interrupt flag in I2Cn_IF to get an interaction from software. The pending status of a command goes low when it is consumed.

When several interactions are possible from a set of pending commands, the interaction with the highest priority, i.e. the interaction closest to the top of Table 15.3 (p. 152) is applied to the bus.

Pending commands can be cleared by setting the CLEARPC command bit in I2Cn_CMD.

15.3.7.2.1 Automatic ACK Interaction

When receiving addresses and data, an ACK command in I2Cn_CMD is normally required after each received byte. When AUTOACK is set in I2Cn_CTRL, an ACK is always pending, and the ACK-pending bit PACK in I2Cn_STATUS is thus always set, even after an ACK has been consumed. This can be used to reduce the amount of software interaction required during a transfer.

15.3.7.3 Reset State

After a reset, the state of the I²C-bus is unknown. To avoid interrupting transfers on the I²C-bus after a reset of the I²C module or the entire MCU, the I²C-bus is assumed to be busy when coming out of a reset, and the BUSY flag in I2Cn_STATUS is thus set. To be able to carry through master operations on the I²C-bus, the bus must be idle.

The bus goes idle when a STOP condition is detected on the bus, but on buses with little activity, the time before the I²C module detects that the bus is idle can be significant. There are two ways of assuring that the I²C module gets out of the busy state.

- Use the ABORT command in I2Cn_CMD. When the ABORT command is issued, the I²C module is instructed that the bus is idle. The I²C module can then initiate master operations.
- Use the Bus Idle Timeout. When SCL has been high for a long period of time, it is very likely that the bus is idle. Set BITO in I2Cn_CTRL to an appropriate timeout period and set GIBITO in I2Cn_CTRL. If activity has not been detected on the bus within the timeout period, the bus is then automatically assumed idle, and master operations can be initiated.

Note

If operating in slave mode, the above approach is not necessary.

15.3.7.4 Master Transmitter

To transmit data to a slave, the master must operate as a master transmitter. Table 15.4 (p. 154) shows the states the I²C module goes through while acting as a master transmitter. Every state where an interaction is required has the possible interactions listed, along with the result of the interactions. The table also shows which interrupt flags are set in the different states. The interrupt flags enclosed in parenthesis may be set. If the BUSHOLD interrupt in I2Cn_IF is set, the module is waiting for an interaction, and the bus is frozen. The value of I2Cn_STATE will be equal to the values given in the table when the BUSHOLD interrupt flag is set, and can be used to determine which interaction is required to make the transmission continue.

The interrupt flag START in I2Cn_IF is set when the I²C module transmits the START.

A master operation is started by issuing a START command by setting START in I2Cn_CMD. ADDR +W, i.e. the address of the slave to address + the R/W bit is then required by the I²C module. If this is not available in the transmit buffer, then the bus is held and the BUSHOLD interrupt flag is set. The

value of I2Cn_STATE will then be 0x57. As seen in the table, the I²C module also stops in this state if the address is not available after a repeated start condition.

To continue, write a byte to I2Cn_TXDATA with the address of the slave in the 7 most significant bits and the least significant bit cleared (ADDR+W). This address will then be transmitted, and the slave will reply with an ACK or a NACK. If no slave replies to the address, the response will also be NACK. If the address was acknowledged, the master now has four choices. If another byte is made available in I2Cn_TXDATA, this byte is transmitted. The master can also stop the transmission by sending a STOP, it can send a repeated start by sending START, or it can send a STOP and then a START as soon as possible.

If a NACK was received, the master has to issue a CONT command in addition to providing data in order to continue transmission. This is not standard I²C, but is provided for flexibility. The rest of the options are similar to when an ACK was received.

If a new byte was transmitted, an ACK or NACK is received after the transmission of the byte, and the master has the same options as for when the address was sent.

The master may lose arbitration at any time during transmission. In this case, the ARBLOST interrupt flag in I2Cn_IF is set. If the arbitration was lost during the transfer of an address, and SLAVE in I2Cn_CTRL is set, the master then checks which address was transmitted. If it was the address of the master, then the master goes to slave mode.

After a master has transmitted a START and won any arbitration, it owns the bus until it transmits a STOP. After a STOP, the bus is released, and arbitration decides which bus master gains the bus next. The MSTOP interrupt flag in I2Cn_IF is set when a STOP condition is transmitted by the master.

Table 15.4. I²C Master Transmitter

I2Cn_STATE	Description	I2Cn_IF	Required interaction	Response
0x57	Start transmitted	START interrupt flag (BUSHOLD interrupt flag)	ADDR +W -> TXDATA	ADDR+W will be sent
			STOP	STOP will be sent and bus released.
			STOP + START	STOP will be sent and bus released. Then a START will be sent when bus becomes idle.
0x57	Repeated start transmitted	START interrupt flag (BUSHOLD interrupt flag)	ADDR +W -> TXDATA	ADDR+W will be sent
			STOP	STOP will be sent and bus released.
			STOP + START	STOP will be sent and bus released. Then a START will be sent when bus becomes idle.
-	ADDR+W transmitted	TXBL interrupt flag (TXC interrupt flag)	None	
0x97	ADDR+W transmitted, ACK received	ACK interrupt flag (BUSHOLD interrupt flag)	TXDATA	DATA will be sent
			STOP	STOP will be sent. Bus will be released
			START	Repeated start condition will be sent
			STOP + START	STOP will be sent and the bus released. Then a START will be sent when the bus becomes idle
0x9F	ADDR+W transmitted, NACK received	NACK (BUSHOLD interrupt flag)	CONT + TXDATA	DATA will be sent
			STOP	STOP will be sent. Bus will be released

I2Cn_STA1	Description	I2Cn_IF	Required interaction	Response
			START	Repeated start condition will be sent
			STOP + START	STOP will be sent and the bus released. Then a START will be sent when the bus becomes idle
-	Data transmitted	TXBL interrupt flag (TXC interrupt flag)	None	
0xD7	Data transmitted,ACK received	ACK interrupt flag (BUSHOLD interrupt flag)	TXDATA	DATA will be sent
			STOP	STOP will be sent. Bus will be released
			START	Repeated start condition will be sent
			STOP + START	STOP will be sent and the bus released. Then a START will be sent when the bus becomes idle
0xDF	Data transmitted,NACK received	NACK(BUSHOLD interrupt flag)	CONT + TXDATA	DATA will be sent
			STOP	STOP will be sent. Bus will be released
			START	Repeated start condition will be sent
			STOP + START	STOP will be sent and the bus released. Then a START will be sent when the bus becomes idle
-	Stop transmitted	MSTOP interrupt flag	None	
			START	START will be sent when bus becomes idle
-	Arbitration lost	ARBLOST interrupt flag	None	
			START	START will be sent when bus becomes idle

15.3.7.5 Master Receiver

To receive data from a slave, the master must operate as a master receiver, see Table 15.5 (p. 156). This is done by transmitting ADDR+R as the address byte instead of ADDR+W, which is transmitted to become a master transmitter. The address byte loaded into the data register thus has to contain the 7-bit slave address in the 7 most significant bits of the byte, and have the least significant bit set.

When the address has been transmitted, the master receives an ACK or a NACK. If an ACK is received, the ACK interrupt flag in I2Cn_IF is set, and if space is available in the receive shift register, reception of a byte from the slave begins. If the receive buffer and shift register is full however, the bus is held until data is read from the receive buffer or another interaction is made. Note that the STOP and START interactions have a higher priority than the data-available interaction, so if a STOP or START command is pending, the highest priority interaction will be performed, and data will not be received from the slave.

If a NACK was received, the CONT command in I2Cn_CMD has to be issued in order to continue receiving data, even if there is space available in the receive buffer and/or shift register.

After a data byte has been received the master must ACK or NACK the received byte. If an ACK is pending or AUTOACK in I2Cn_CTRL is set, an ACK is sent automatically and reception continues if space is available in the receive buffer.

If a NACK is sent, the CONT command must be used in order to continue transmission. If an ACK or NACK is issued along with a START or STOP or both, then the ACK/NACK is transmitted and the reception is ended. If START in I2Cn_CMD is set alone, a repeated start condition is transmitted after the ACK/NACK. If STOP in I2Cn_CMD is set, a stop condition is sent regardless of whether START is set. If START is set in this case, it is set as pending.

As when operating as a master transmitter, arbitration can be lost as a master receiver. When this happens the ARBLOST interrupt flag in I2Cn_IF is set, and the master has a possibility of being selected as a slave given the correct conditions.

Table 15.5. I²C Master Receiver

I2Cn_STA1	Description	I2Cn_IF	Required interaction	Response
0x57	START transmitted	START interrupt flag (BUSHOLD interrupt flag)	ADDR +R -> TXDATA	ADDR+R will be sent
			STOP	STOP will be sent and bus released.
			STOP + START	STOP will be sent and bus released. Then a START will be sent when bus becomes idle.
0x57	Repeated START transmitted	START interrupt flag(BUSHOLD interrupt flag)	ADDR +R -> TXDATA	ADDR+R will be sent
			STOP	STOP will be sent and bus released.
			STOP + START	STOP will be sent and bus released. Then a START will be sent when bus becomes idle.
-	ADDR+R transmitted	TXBL interrupt flag (TXC interrupt flag)	None	
0x93	ADDR+R transmitted, ACK received	ACK interrupt flag(BUSHOLD)	RXDATA	Start receiving
			STOP	STOP will be sent and the bus released
			START	Repeated START will be sent
			STOP + START	STOP will be sent and the bus released. Then a START will be sent when the bus becomes idle
0x9B	ADDR+R transmitted,NACK received	NACK(BUSHOLD)	CONT + RXDATA	Continue, start receiving
			STOP	STOP will be sent and the bus released
			START	Repeated START will be sent
			STOP + START	STOP will be sent and the bus released. Then a START will be sent when the bus becomes idle
0xB3	Data received	RXDATA interrupt flag(BUSHOLD interrupt flag)	ACK + RXDATA	ACK will be transmitted, reception continues
			NACK + CONT + RXDATA	NACK will be transmitted, reception continues
			ACK/ NACK + STOP	ACK/NACK will be sent and the bus will be released.
			ACK/ NACK + START	ACK/NACK will be sent, and then a repeated start condition.
			ACK/ NACK + STOP + START	ACK/NACK will be sent and the bus will be released. Then a START will be sent when the bus becomes idle
-	Stop received	MSTOP interrupt flag	None	

I2Cn_STA1	Description	I2Cn_IF	Required interaction	Response
			START	START will be sent when bus becomes idle
-	Arbitration lost	ARBLOST interrupt flag	None	
			START	START will be sent when bus becomes idle

15.3.8 Bus States

The I2Cn_STATE register can be used to determine which state the I²C module and the I2C bus are in at a given time. The register consists of the STATE bit-field, which shows which state the I²C module is at in any ongoing transmission, and a set of single-bits, which reveal the transmission mode, whether the bus is busy or idle, and whether the bus is held by this I²C module waiting for a software response.

The possible values of the STATE field are summarized in Table 15.6 (p. 157). When this field is cleared, the I²C module is not a part of any ongoing transmission. The remaining status bits in the I2Cn_STATE register are listed in Table 15.7 (p. 157).

Table 15.6. I²C STATE Values

Mode	Value	Description
IDLE	0	No transmission is being performed by this module.
WAIT	1	Waiting for idle. Will send a start condition as soon as the bus is idle.
START	2	Start being transmitted
ADDR	3	Address being transmitted or has been received
ADDRACK	4	Address ACK/NACK being transmitted or received
DATA	5	Data being transmitted or received
DATAACK	6	Data ACK/NACK being transmitted or received

Table 15.7. I²C Transmission Status

Bit	Description
BUSY	Set whenever there is activity on the bus. Whether or not this module is responsible for the activity cannot be determined by this byte.
MASTER	Set when operating as a master. Cleared at all other times.
TRANSMITTER	Set when operating as a transmitter; either a master transmitter or a slave transmitter. Cleared at all other times
BUSHOLD	Set when the bus is held by this I ² C module because an action is required by software.
NACK	Only valid when bus is held and STATE is ADDRACK or DATAACK. In that case it is set if a NACK was received. In all other cases, the bit is cleared.

Note

I2Cn_STATE reflects the internal state of the I²C module, and therefore only held constant as long as the bus is held, i.e. as long as BUSHOLD in I2Cn_STATUS is set.

15.3.9 Slave Operation

The I²C module operates in master mode by default. To enable slave operation, i.e. to allow the device to be addressed as an I²C slave, the SLAVE bit in I2Cn_CTRL must be set. In this case the slave operates in a mixed mode, both capable of starting transmissions as a master, and being addressed as a slave.

15.3.9.1 Slave State Machine

The slave state machine is shown in Figure 15.11 (p. 158). The dotted lines show where I²C-specific interrupt flags are set. The full-drawn circles show places where interaction may be required by software to let the transmission proceed.

Figure 15.11. I²C Slave State Machine

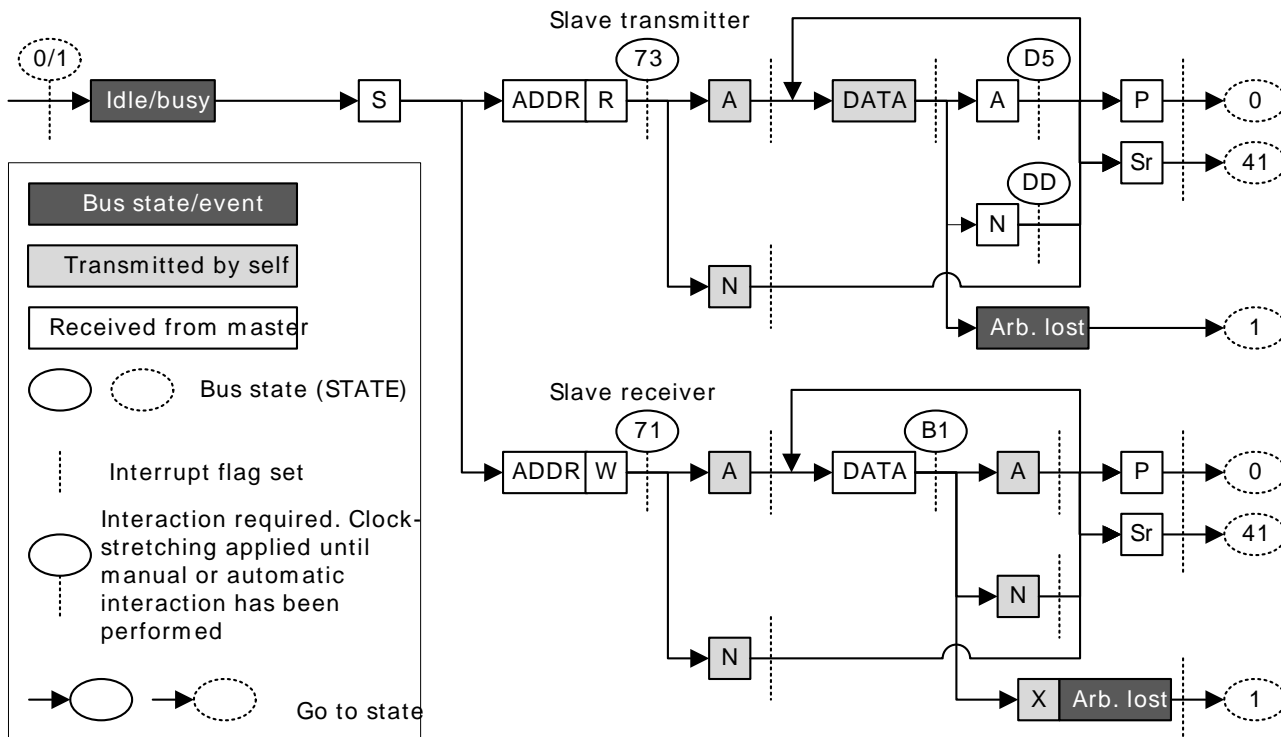

15.3.9.2 Address Recognition

The I²C module provides automatic address recognition for 7-bit addresses. 10-bit address recognition is not fully automatic, but can be assisted by the 7-bit address comparator as shown in Section 15.3.11 (p. 162). Address recognition is supported in all energy modes.

The slave address, i.e. the address which the I²C module should be addressed with, is defined in the I2Cn_SADDR register. In addition to the address, a mask must be specified, telling the address comparator which bits of an incoming address to compare with the address defined in I2Cn_SADDR. The mask is defined in I2Cn_SADDRMASK, and for every zero in the mask, the corresponding bit in the slave address is treated as a don't-care.

An incoming address that fails address recognition is automatically replied to with a NACK. Since only the bits defined by the mask are checked, a mask with a value 0x00 will result in all addresses being accepted. A mask with a value 0x7F will only match the exact address defined in I2Cn_SADDR, while a mask 0x70 will match all addresses where the three most significant bits in I2Cn_SADDR and the incoming address are equal.

If GCAMEN in I2Cn_CTRL is set, the general call address is always accepted regardless of the result of the address recognition. The start-byte, i.e. the general call address with the R/W bit set is ignored unless it is included in the defined slave address.

When an address is accepted by the address comparator, the decision of whether to ACK or NACK the address is passed to software.

15.3.9.3 Slave Transmitter

When SLAVE in I2Cn_CTRL is set, the RSTART interrupt flag in I2Cn_IF will be set when repeated START conditions are detected. No interaction is required on this event however.

After a START or repeated START condition, the bus master will transmit an address along with an R/W bit. If there is no room in the receive shift register for the address, the bus will be held by the slave until room is available in the shift register. Transmission then continues and the address is loaded into the shift register. If this address does not pass address recognition, it is automatically NACK'ed by the slave, and the slave goes to an idle state. The address byte is in this case discarded, making the shift register ready for a new address. It is not loaded into the receive buffer.

If the address was accepted and the R/W bit was set (R), indicating that the master wishes to read from the slave, the slave now goes into the slave transmitter mode. Software interaction is now required to decide whether the slave wants to acknowledge the request or not. The accepted address byte is loaded into the receive buffer like a regular data byte. If no valid interaction is pending, the bus is held until the slave responds with a command. The slave can reject the request with a single NACK command.

The slave will in that case go to an idle state, and wait for the next start condition. To continue the transmission, the slave must make sure data is loaded into the transmit buffer and send an ACK. The loaded data will then be transmitted to the master, and an ACK or NACK will be received from the master.

Data transmission can also continue after a NACK if a CONT command is issued along with the NACK. This is not standard I²C however.

If the master responds with an ACK, it may expect another byte of data, and data should be made available in the transmit buffer. If data is not available, the bus is held until data is available.

If the response is a NACK however, this is an indication of that the master has received enough bytes and wishes to end the transmission. The slave now automatically goes idle, unless CONT in I2Cn_CMD is set and data is available for transmission. The latter is not standard I²C.

The master ends the transmission by sending a STOP or a repeated START. The SSTOP interrupt flag in I2Cn_IF is set when the master transmits a STOP condition. If the transmission is ended with a repeated START, then the SSTOP interrupt flag is not set.

Note

The SSTOP interrupt flag in I2Cn_IF will be set regardless of whether the slave is participating in the transmission or not, as long as SLAVE in I2Cn_CTRL is set and a STOP condition is detected

If arbitration is lost at any time during transmission, the ARBLOST interrupt flag in I2Cn_IF is set, the bus is released and the slave goes idle.

See Table 15.8 (p. 160) for more information.

Table 15.8. I²C Slave Transmitter

I2Cn_STA7	Description	I2Cn_IF	Required interaction	Response
0x41	Repeated START received	RSTART interrupt flag (BUSHOLD interrupt flag)	RXDATA	Receive and compare address
0x73	ADDR + R received	ADDR interrupt flag	ACK + TXDATA	ACK will be sent, then DATA
		RXDATA interrupt flag	NACK	NACK will be sent, slave goes idle
		(BUSHOLD interrupt flag)	NACK + CONT + TXDATA	NACK will be sent, then DATA.
-	Data transmitted	TXBL interrupt flag (TXC interrupt flag)	None	
0xD5	Data transmitted, ACK received	ACK interrupt flag (BUSHOLD interrupt flag)	TXDATA	DATA will be transmitted
0xDD	Data transmitted, NACK received	NACK interrupt flag	None	The slave goes idle
		(BUSHOLD interrupt flag)	CONT + TXDATA	DATA will be transmitted
-	Stop received	SSTOP interrupt flag	None	The slave goes idle
			START	START will be sent when bus becomes idle
-	Arbitration lost	ARBLOST interrupt flag	None	The slave goes idle
			START	START will be sent when the bus becomes idle

15.3.9.4 Slave Receiver

A slave receiver operation is started in the same way as a slave transmitter operation, with the exception that the address transmitted by the master has the R/W bit cleared (W), indicating that the master wishes to write to the slave. The slave then goes into slave receiver mode.

To receive data from the master, the slave should respond to the address with an ACK and make sure space is available in the receive buffer. Transmission will then continue, and the slave will receive a byte from the master.

If a NACK is sent without a CONT, the transmission is ended for the slave, and it goes idle. If the slave issues both the NACK and CONT commands and has space available in the receive buffer, it will be open for continuing reception from the master.

When a byte has been received from the master, the slave must ACK or NACK the byte. The responses here are the same as for the reception of the address byte.

The master ends the transmission by sending a STOP or a repeated START. The SSTOP interrupt flag is set when the master transmits a STOP condition. If the transmission is ended with a repeated START, then the SSTOP interrupt flag in I2Cn_IF is not set.

Note

The SSTOP interrupt flag in I2Cn_IF will be set regardless of whether the slave is participating in the transmission or not, as long as SLAVE in I2Cn_CTRL is set and a STOP condition is detected

If arbitration is lost at any time during transmission, the ARBLOST interrupt flag in I2Cn_IF is set, the bus is released and the slave goes idle.

See Table 15.9 (p. 161) for more information.

Table 15.9. I²C - Slave Receiver

I2Cn_STA1	Description	I2Cn_IF	Required interaction	Response
-	Repeated START received	RSTART interrupt flag (BUSHOLD interrupt flag)	RXDATA	Receive and compare address
0x71	ADDR + W received	ADDR interrupt flag RXDATA interrupt flag (BUSHOLD interrupt flag)	ACK + RXDATA	ACK will be sent and data will be received
			NACK	NACK will be sent, slave goes idle
			NACK + CONT + RXDATA	NACK will be sent and DATA will be received.
0xB1	Data received	RXDATA interrupt flag (BUSHOLD interrupt flag)	ACK + RXDATA	ACK will be sent and data will be received
			NACK	NACK will be sent and slave will go idle
			NACK + CONT + RXDATA	NACK will be sent and data will be received
-	Stop received	SSTOP interrupt flag	None	The slave goes idle
			START	START will be sent when bus becomes idle
-	Arbitration lost	ARBLOST interrupt flag	None	The slave goes idle
			START	START will be sent when the bus becomes idle

15.3.10 Transfer Automation

The I²C can be set up to complete transfers with a minimal amount of interaction.

15.3.10.1 DMA

DMA can be used to automatically load data into the transmit buffer and load data out from the receive buffer. When using DMA, software is thus relieved of moving data to and from memory after each transferred byte.

15.3.10.2 Automatic ACK

When AUTOACK in I2Cn_CTRL is set, an ACK is sent automatically whenever an ACK interaction is possible and no higher priority interactions are pending.

15.3.10.3 Automatic STOP

A STOP can be generated automatically on two conditions. These apply only to the master transmitter.

If AUTOSN in I2Cn_CTRL is set, the I²C module ends a transmission by transmitting a STOP condition when operating as a master transmitter and a NACK is received.

If AUTOSE in I2Cn_CTRL is set, the I²C module always ends a transmission when there is no more data in the transmit buffer. If data has been transmitted on the bus, the transmission is ended after the (N)ACK has been received by the slave. If a START is sent when no data is available in the transmit buffer and AUTOSE is set, then the STOP condition is sent immediately following the START. Software must thus make sure data is available in the transmit buffer before the START condition has been fully transmitted if data is to be transferred.

15.3.11 Using 10-bit Addresses

When using 10-bit addresses in slave mode, set the I2Cn_SADDR register to 1111 0XX where XX are the two most significant bits of the 10-bit address, and set I2Cn_SADDRMASK to 0xFF. Address matches will now be given on all 10-bit addresses where the two most significant bits are correct.

When receiving an address match, the slave must acknowledge the address and receive the first data byte. This byte contains the second part of the 10-bit address. If it matches the address of the slave, the slave should ACK the byte to continue the transmission, and if it does not match, the slave should NACK it.

When the master is operating as a master transmitter, the data bytes will follow after the second address byte. When the master is operating as a master receiver however, a repeated START condition is sent after the second address byte. The address sent after this repeated START is equal to the first of the address bytes transmitted previously, but now with the R/W byte set, and only the slave that found a match on the entire 10-bit address in the previous message should ACK this address. The repeated start should take the master into a master receiver mode, and after the single address byte sent this time around, the slave begins transmission to the master.

15.3.12 Error Handling

15.3.12.1 ABORT command

Some bus errors may require software intervention to be resolved. The I²C module provides an ABORT command, which can be set in I2Cn_CMD, to help resolve bus errors.

When the bus for some reason is locked up and the I²C module is in the middle of a transmission it cannot get out of, or for some other reason the I²C wants to abort a transmission, the ABORT command can be used.

Setting the ABORT command will make the I²C module discard any data currently being transmitted or received, release the SDA and SCL lines and go to an idle mode. ABORT effectively makes the I²C module forget about any ongoing transfers.

15.3.12.2 Bus Reset

A bus reset can be performed by setting the START and STOP commands in I2Cn_CMD while the transmit buffer is empty. A START condition will then be transmitted, immediately followed by a STOP condition. A bus reset can also be performed by transmitting a START command with the transmit buffer empty and AUTOSE set.

15.3.12.3 I²C-Bus Errors

An I²C-bus error occurs when a START or STOP condition is misplaced, which happens when the value on SDA changes while SCL is high during bit-transmission on the I²C-bus. If the I²C module is part of the current transmission when a bus error occurs, any data currently being transmitted or received is discarded, SDA and SCL are released, the BUSERR interrupt flag in I2Cn_IF is set to indicate the error, and the module automatically takes a course of action as defined in Table 15.10 (p. 162).

Table 15.10. I²C Bus Error Response

	Misplaced START	Misplaced STOP
In a master/slave operation	Treated as START. Receive address.	Go idle. Perform any pending actions.

15.3.12.4 Bus Lockup

A lockup occurs when a master or slave on the I²C-bus has locked the SDA or SCL at a low value, preventing other devices from putting high values on the bus, and thus making communication on the bus impossible.

Many slave-only devices operating on an I²C-bus are not capable of driving SCL low, but in the rare case that SCL is stuck LOW, the advice is to apply a hardware reset signal to the slaves on the bus. If this does not work, cycle the power to the devices in order to make them release SCL.

When SDA is stuck low and SCL is free, a master should send 9 clock pulses on SCL while tristating the SDA. This procedure is performed in the GPIO module after clearing the I2C_ROUTE register and disabling the I2C module. The device that held the bus low should release it sometime within those 9 clocks. If not, use the same approach as for when SCL is stuck, resetting and possibly cycling power to the slaves.

Lockup of SDA can be detected by keeping count of the number of continuous arbitration losses during address transmission. If arbitration is also lost during the transmission of a general call address, i.e. during the transmission of the STOP condition, which should never happen during normal operation, this is a good indication of SDA lockup.

Detection of SCL lockups can be done using the timeout functionality defined in Section 15.3.12.6 (p. 163)

15.3.12.5 Bus Idle Timeout

When SCL has been high for a significant amount of time, this is a good indication of that the bus is idle. On an SMBus system, the bus is only allowed to be in this state for a maximum of 50 µs before the bus is considered idle.

The bus idle timeout BITO in I2Cn_CTRL can be used to detect situations where the bus goes idle in the middle of a transmission. The timeout can be configured in BITO, and when the bus has been idle for the given amount of time, the BITO interrupt flag in I2Cn_IF is set. The bus can also be set idle automatically on a bus idle timeout. This is enabled by setting GIBITO in I2Cn_CTRL.

When the bus idle timer times out, it wraps around and continues counting as long as its condition is true. If the bus is not set idle using GIBITO or the ABORT command in I2Cn_CMD, this will result in periodic timeouts.

Note

This timeout will be generated even if SDA is held low.

The bus idle timeout is active as long as the bus is busy, i.e. BUSY in I2Cn_STATUS is set. The timeout can be used to get the I²C module out of the busy-state it enters when reset, see Section 15.3.7.3 (p. 153).

15.3.12.6 Clock Low Timeout

The clock timeout, which can be configured in CLTO in I2Cn_CTRL, starts counting whenever SCL goes low, and times out if SCL does not go high within the configured timeout. A clock low timeout results in CLTOIF in I2Cn_IF being set, allowing software to take action.

When the timer times out, it wraps around and continues counting as long as SCL is low. An SCL lockup will thus result in periodic clock low timeouts as long as SCL is low.

15.3.13 DMA Support

The I²C module has full DMA support. The DMA controller can write to the transmit buffer using the I2Cn_TXDATA register, and it can read from the receive buffer using the RXDATA register. A request for the DMA controller to read from the I²C receive buffer can come from the following source:

- Data available in the receive buffer

A write request can come from one of the following sources:

- Transmit buffer and shift register empty. No data to send
- Transmit buffer empty

15.3.14 Interrupts

The interrupts generated by the I²C module are combined into one interrupt vector, I2C_INT. If I²C interrupts are enabled, an interrupt will be made if one or more of the interrupt flags in I2Cn_IF and their corresponding bits in I2Cn_IEN are set.

15.3.15 Wakeup

The I²C receive section can be active all the way down to energy mode EM3, and can wake up the CPU on address interrupt. All address match modes are supported.

15.4 Register Map

The offset register address is relative to the registers base address.

Offset	Name	Type	Description
0x000	I2Cn_CTRL	RW	Control Register
0x004	I2Cn_CMD	W1	Command Register
0x008	I2Cn_STATE	R	State Register
0x00C	I2Cn_STATUS	R	Status Register
0x010	I2Cn_CLKDIV	RW	Clock Division Register
0x014	I2Cn_SADDR	RW	Slave Address Register
0x018	I2Cn_SADDRMASK	RW	Slave Address Mask Register
0x01C	I2Cn_RXDATA	R	Receive Buffer Data Register
0x020	I2Cn_RXDATAP	R	Receive Buffer Data Peek Register
0x024	I2Cn_TXDATA	W	Transmit Buffer Data Register
0x028	I2Cn_IF	R	Interrupt Flag Register
0x02C	I2Cn_IFS	W1	Interrupt Flag Set Register
0x030	I2Cn_IFC	W1	Interrupt Flag Clear Register
0x034	I2Cn_IEN	RW	Interrupt Enable Register
0x038	I2Cn_ROUTE	RW	I/O Routing Register

15.5 Register Description

15.5.1 I2Cn_CTRL - Control Register

Offset	Bit Position																																
	31	30	29	28	27	26	25	24	23	22	21	20	19	18	17	16	15	14	13	12	11	10	9	8	7	6	5	4	3	2	1	0	
0x000																																	
Reset															0x0		0			0x0				0x0				0	0	0	0	0	0
Access															RW		RW			RW				RW				RW	RW	RW	RW	RW	RW
Name															CLTO		GIBITO			BITO				CLHR			GCAMEN	ARBDIS	AUTOSN	AUTOSE	AUTOACK	SLAVE	EN

Bit	Name	Reset	Access	Description
31:19	Reserved			To ensure compatibility with future devices, always write bits to 0. More information in Section 2.1 (p. 3)

18:16 CLTO 0x0 RW **Clock Low Timeout**

Use to generate a timeout when CLK has been low for the given amount of time. Wraps around and continues counting when the timeout is reached.

Value	Mode	Description
0	OFF	Timeout disabled
1	40PCC	Timeout after 40 prescaled clock cycles. In standard mode at 100 kHz, this results in a 50us timeout.
2	80PCC	Timeout after 80 prescaled clock cycles. In standard mode at 100 kHz, this results in a 100us timeout.
3	160PCC	Timeout after 160 prescaled clock cycles. In standard mode at 100 kHz, this results in a 200us timeout.
4	320PPC	Timeout after 320 prescaled clock cycles. In standard mode at 100 kHz, this results in a 400us timeout.
5	1024PPC	Timeout after 1024 prescaled clock cycles. In standard mode at 100 kHz, this results in a 1280us timeout.

15 GIBITO 0 RW **Go Idle on Bus Idle Timeout**

Bit	Name	Reset	Access	Description
-----	------	-------	--------	-------------

When set, the bus automatically goes idle on a bus idle timeout, allowing new transfers to be initiated.

Value	Description
0	A bus idle timeout has no effect on the bus state.
1	A bus idle timeout tells the I ² C module that the bus is idle, allowing new transfers to be initiated.

14 *Reserved* *To ensure compatibility with future devices, always write bits to 0. More information in Section 2.1 (p. 3)*

13:12 **BITO** 0x0 RW **Bus Idle Timeout**

Use to generate a timeout when SCL has been high for a given amount time between a START and STOP condition. When in a bus transaction, i.e. the BUSY flag is set, a timer is started whenever SCL goes high. When the timer reaches the value defined by BITO, it sets the BITO interrupt flag. The BITO interrupt flag will then be set periodically as long as SCL remains high. The bus idle timeout is active as long as BUSY is set. It is thus stopped automatically on a timeout if GIBITO is set. It is also stopped a STOP condition is detected and when the ABORT command is issued. The timeout is activated whenever the bus goes BUSY, i.e. a START condition is detected.

Value	Mode	Description
0	OFF	Timeout disabled
1	40PCC	Timeout after 40 prescaled clock cycles. In standard mode at 100 kHz, this results in a 50us timeout.
2	80PCC	Timeout after 80 prescaled clock cycles. In standard mode at 100 kHz, this results in a 100us timeout.
3	160PCC	Timeout after 160 prescaled clock cycles. In standard mode at 100 kHz, this results in a 200us timeout.

11:10 *Reserved* *To ensure compatibility with future devices, always write bits to 0. More information in Section 2.1 (p. 3)*

9:8 **CLHR** 0x0 RW **Clock Low High Ratio**

Determines the ratio between the low and high parts of the clock signal generated on SCL as master.

Value	Mode	Description
0	STANDARD	The ratio is 4:4. Both low and high periods lasts 4 prescaled clock cycles
1	ASYMMETRIC	The ratio is 6:3. Low period lasts 6 and high period lasts 4 prescaled clock cycles
2	FAST	The ratio is 11:6. Low period lasts 16 and high period lasts 9 prescaled clock cycles

7 *Reserved* *To ensure compatibility with future devices, always write bits to 0. More information in Section 2.1 (p. 3)*

6 **GCAMEN** 0 RW **General Call Address Match Enable**

Set to enable address match on general call in addition to the programmed slave address.

Value	Description
0	General call address will be NACK'ed if it is not included by the slave address and address mask.
1	When a general call address is received, a software response is required.

5 **ARBDIS** 0 RW **Arbitration Disable**

A master or slave will not release the bus upon losing arbitration.

Value	Description
0	When a device loses arbitration, the ARB interrupt flag is set and the bus is released.
1	When a device loses arbitration, the ARB interrupt flag is set, but communication proceeds.

4 **AUTOSN** 0 RW **Automatic STOP on NACK**

Write to 1 to make a master transmitter send a STOP when a NACK is received from a slave.

Value	Description
0	Stop is not automatically sent if a NACK is received from a slave.
1	The master automatically sends a STOP if a NACK is received from a slave.

3 **AUTOSE** 0 RW **Automatic STOP when Empty**

Write to 1 to make a master transmitter send a STOP when no more data is available for transmission.

Value	Description
0	A stop must be sent manually when no more data is to be transmitted.
1	The master automatically sends a STOP when no more data is available for transmission.

2 **AUTOACK** 0 RW **Automatic Acknowledge**

Set to enable automatic acknowledges.

Bit	Name	Reset	Access	Description
8	RXDATAV	0	R	RX Data Valid Set when data is available in the receive buffer. Cleared when the receive buffer is empty.
7	TXBL	1	R	TX Buffer Level Indicates the level of the transmit buffer. Set when the transmit buffer is empty, and cleared when it is full.
6	TXC	0	R	TX Complete Set when a transmission has completed and no more data is available in the transmit buffer. Cleared when a new transmission starts.
5	PABORT	0	R	Pending abort An abort is pending and will be transmitted as soon as possible.
4	PCONT	0	R	Pending continue A continue is pending and will be transmitted as soon as possible.
3	PNACK	0	R	Pending NACK A not-acknowledge is pending and will be transmitted as soon as possible.
2	PACK	0	R	Pending ACK An acknowledge is pending and will be transmitted as soon as possible.
1	PSTOP	0	R	Pending STOP A stop condition is pending and will be transmitted as soon as possible.
0	PSTART	0	R	Pending START A start condition is pending and will be transmitted as soon as possible.

15.5.5 I2Cn_CLKDIV - Clock Division Register

Offset	Bit Position																															
0x010	31	30	29	28	27	26	25	24	23	22	21	20	19	18	17	16	15	14	13	12	11	10	9	8	7	6	5	4	3	2	1	0
Reset																									0x000							
Access																									RW							
Name																									DIV							

Bit	Name	Reset	Access	Description
31:9	Reserved	<i>To ensure compatibility with future devices, always write bits to 0. More information in Section 2.1 (p. 3)</i>		
8:0	DIV	0x000	RW	Clock Divider Specifies the clock divider for the I ² C. Note that DIV must be 1 or higher when slave is enabled.

15.5.6 I2Cn_SADDR - Slave Address Register

Offset	Bit Position																															
0x014	31	30	29	28	27	26	25	24	23	22	21	20	19	18	17	16	15	14	13	12	11	10	9	8	7	6	5	4	3	2	1	0
Reset																									0x00							
Access																									RW							
Name																									ADDR							

Bit	Name	Reset	Access	Description
31:8	Reserved	To ensure compatibility with future devices, always write bits to 0. More information in Section 2.1 (p. 3)		
7:1	ADDR	0x00	RW	Slave address Specifies the slave address of the device.
0	Reserved	To ensure compatibility with future devices, always write bits to 0. More information in Section 2.1 (p. 3)		

15.5.7 I2Cn_SADDRMASK - Slave Address Mask Register

Offset	Bit Position																															
0x018	31	30	29	28	27	26	25	24	23	22	21	20	19	18	17	16	15	14	13	12	11	10	9	8	7	6	5	4	3	2	1	0
Reset																									0x00							
Access																									RW							
Name																									MASK							

Bit	Name	Reset	Access	Description
31:8	Reserved	To ensure compatibility with future devices, always write bits to 0. More information in Section 2.1 (p. 3)		
7:1	MASK	0x00	RW	Slave Address Mask Specifies the significant bits of the slave address. Setting the mask to 0x00 will match all addresses, while setting it to 0x7F will only match the exact address specified by ADDR.
0	Reserved	To ensure compatibility with future devices, always write bits to 0. More information in Section 2.1 (p. 3)		

15.5.8 I2Cn_RXDATA - Receive Buffer Data Register

Offset	Bit Position																															
0x01C	31	30	29	28	27	26	25	24	23	22	21	20	19	18	17	16	15	14	13	12	11	10	9	8	7	6	5	4	3	2	1	0
Reset																									0x00							
Access																									R							
Name																									RXDATA							

Bit	Name	Reset	Access	Description
31:8	Reserved	To ensure compatibility with future devices, always write bits to 0. More information in Section 2.1 (p. 3)		
7:0	RXDATA	0x00	R	RX Data Use this register to read from the receive buffer. Buffer is emptied on read access.

Bit	Name	Reset	Access	Description
				Set on each clock low timeout. The timeout value can be set in CLTO bitfield in the I2Cn_CTRL register.
14	BITO	0	R	Bus Idle Timeout Interrupt Flag Set on each bus idle timeout. The timeout value can be set in the BITO bitfield in the I2Cn_CTRL register.
13	RXUF	0	R	Receive Buffer Underflow Interrupt Flag Set when data is read from the receive buffer through the I2Cn_RXDATA register while the receive buffer is empty.
12	TXOF	0	R	Transmit Buffer Overflow Interrupt Flag Set when data is written to the transmit buffer while the transmit buffer is full.
11	BUSHOLD	0	R	Bus Held Interrupt Flag Set when the bus becomes held by the I ² C module.
10	BUSERR	0	R	Bus Error Interrupt Flag Set when a bus error is detected. The bus error is resolved automatically, but the current transfer is aborted.
9	ARBLOST	0	R	Arbitration Lost Interrupt Flag Set when arbitration is lost.
8	MSTOP	0	R	Master STOP Condition Interrupt Flag Set when a STOP condition has been successfully transmitted. If arbitration is lost during the transmission of the STOP condition, then the MSTOP interrupt flag is not set.
7	NACK	0	R	Not Acknowledge Received Interrupt Flag Set when a NACK has been received.
6	ACK	0	R	Acknowledge Received Interrupt Flag Set when an ACK has been received.
5	RXDATAV	0	R	Receive Data Valid Interrupt Flag Set when data is available in the receive buffer. Cleared automatically when the receive buffer is read.
4	TXBL	1	R	Transmit Buffer Level Interrupt Flag Set when the transmit buffer becomes empty. Cleared automatically when new data is written to the transmit buffer.
3	TXC	0	R	Transfer Completed Interrupt Flag Set when the transmit shift register becomes empty and there is no more data in the transmit buffer.
2	ADDR	0	R	Address Interrupt Flag Set when incoming address is accepted, i.e. own address or general call address is received.
1	RSTART	0	R	Repeated START condition Interrupt Flag Set when a repeated start condition is detected.
0	START	0	R	START condition Interrupt Flag Set when a start condition is successfully transmitted.

15.5.12 I2Cn_IFS - Interrupt Flag Set Register

Offset	Bit Position																																		
	31	30	29	28	27	26	25	24	23	22	21	20	19	18	17	16	15	14	13	12	11	10	9	8	7	6	5	4	3	2	1	0			
0x02C																																			
Reset																0	0	0	0	0	0	0	0	0	0	0	0								
Access																W1	W1	W1	W1	W1	W1	W1	W1	W1	W1	W1	W1								
Name																SSTOP	CLTO	BITO	RXUF	TXOF	BUSHOLD	BUSERR	ARBLOST	MSTOP	NACK	ACK						TXC	ADDR	RSTART	START

Bit	Name	Reset	Access	Description
31:17	Reserved			To ensure compatibility with future devices, always write bits to 0. More information in Section 2.1 (p. 3)

Bit	Name	Reset	Access	Description
16	SSTOP Write to 1 to set the SSTOP interrupt flag.	0	W1	Set SSTOP Interrupt Flag
15	CLTO Write to 1 to set the CLTO interrupt flag.	0	W1	Set Clock Low Interrupt Flag
14	BITO Write to 1 to set the BITO interrupt flag.	0	W1	Set Bus Idle Timeout Interrupt Flag
13	RXUF Write to 1 to set the RXUF interrupt flag.	0	W1	Set Receive Buffer Underflow Interrupt Flag
12	TXOF Write to 1 to set the TXOF interrupt flag.	0	W1	Set Transmit Buffer Overflow Interrupt Flag
11	BUSHOLD Write to 1 to set the BUSHOLD interrupt flag.	0	W1	Set Bus Held Interrupt Flag
10	BUSERR Write to 1 to set the BUSERR interrupt flag.	0	W1	Set Bus Error Interrupt Flag
9	ARBLOST Write to 1 to set the ARBLOST interrupt flag.	0	W1	Set Arbitration Lost Interrupt Flag
8	MSTOP Write to 1 to set the MSTOP interrupt flag.	0	W1	Set MSTOP Interrupt Flag
7	NACK Write to 1 to set the NACK interrupt flag.	0	W1	Set Not Acknowledge Received Interrupt Flag
6	ACK Write to 1 to set the ACK interrupt flag.	0	W1	Set Acknowledge Received Interrupt Flag
5:4	<i>Reserved</i>	<i>To ensure compatibility with future devices, always write bits to 0. More information in Section 2.1 (p. 3)</i>		
3	TXC Write to 1 to set the TXC interrupt flag.	0	W1	Set Transfer Completed Interrupt Flag
2	ADDR Write to 1 to set the ADDR interrupt flag.	0	W1	Set Address Interrupt Flag
1	RSTART Write to 1 to set the RSTART interrupt flag.	0	W1	Set Repeated START Interrupt Flag
0	START Write to 1 to set the START interrupt flag.	0	W1	Set START Interrupt Flag

15.5.13 I2Cn_IFC - Interrupt Flag Clear Register

Offset	Bit Position																																																		
0x030	31	30	29	28	27	26	25	24	23	22	21	20	19	18	17	16	15	14	13	12	11	10	9	8	7	6	5	4	3	2	1	0																			
Reset																	0	0	0	0	0	0	0	0	0	0	0	0	0	0	0	0	0	0	0	0	0	0	0	0	0	0	0	0	0	0	0	0			
Access																	W1	W1	W1	W1	W1	W1	W1	W1	W1	W1	W1	W1	W1	W1	W1	W1	W1	W1	W1	W1	W1	W1	W1	W1	W1	W1	W1	W1	W1	W1	W1	W1	W1		
Name																	SSTOP	CLTO	BITO	RXUF	TXOF	BUSHOLD	BUSERR	ARBLOST	MSTOP	NACK	ACK																								

Bit	Name	Reset	Access	Description
31:17	<i>Reserved</i>	<i>To ensure compatibility with future devices, always write bits to 0. More information in Section 2.1 (p. 3)</i>		
16	SSTOP	0	W1	Clear SSTOP Interrupt Flag

Bit	Name	Reset	Access	Description
15	CLTO Enable interrupt on clock low timeout.	0	RW	Clock Low Interrupt Enable
14	BITO Enable interrupt on bus idle timeout.	0	RW	Bus Idle Timeout Interrupt Enable
13	RXUF Enable interrupt on receive buffer underflow.	0	RW	Receive Buffer Underflow Interrupt Enable
12	TXOF Enable interrupt on transmit buffer overflow.	0	RW	Transmit Buffer Overflow Interrupt Enable
11	BUSHOLD Enable interrupt on bus-held.	0	RW	Bus Held Interrupt Enable
10	BUSERR Enable interrupt on bus error.	0	RW	Bus Error Interrupt Enable
9	ARBLOST Enable interrupt on loss of arbitration.	0	RW	Arbitration Lost Interrupt Enable
8	MSTOP Enable interrupt on MSTOP.	0	RW	MSTOP Interrupt Enable
7	NACK Enable interrupt when not-acknowledge is received.	0	RW	Not Acknowledge Received Interrupt Enable
6	ACK Enable interrupt on acknowledge received.	0	RW	Acknowledge Received Interrupt Enable
5	RXDATAV Enable interrupt on receive buffer full.	0	RW	Receive Data Valid Interrupt Enable
4	TXBL Enable interrupt on transmit buffer level.	0	RW	Transmit Buffer level Interrupt Enable
3	TXC Enable interrupt on transfer completed.	0	RW	Transfer Completed Interrupt Enable
2	ADDR Enable interrupt on recognized address.	0	RW	Address Interrupt Enable
1	RSTART Enable interrupt on transmitted or received repeated START condition.	0	RW	Repeated START condition Interrupt Enable
0	START Enable interrupt on transmitted or received START condition.	0	RW	START Condition Interrupt Enable

15.5.15 I2Cn_ROUTE - I/O Routing Register

Offset	Bit Position																															
0x038	31	30	29	28	27	26	25	24	23	22	21	20	19	18	17	16	15	14	13	12	11	10	9	8	7	6	5	4	3	2	1	0
Reset																									0x0			0	0			
Access																									RW			RW	RW			
Name																									LOCATION			SCLPEN	SDAPEN			

Bit	Name	Reset	Access	Description
31:10	Reserved	To ensure compatibility with future devices, always write bits to 0. More information in Section 2.1 (p. 3)		

Bit	Name	Reset	Access	Description
9:8	LOCATION	0x0	RW	I/O Location Decides the location of the I ² C I/O pins.
	Value	Mode		Description
	0	LOC0		Location 0
	1	LOC1		Location 1
	2	LOC2		Location 2
	3	LOC3		Location 3
7:2	<i>Reserved</i>	<i>To ensure compatibility with future devices, always write bits to 0. More information in Section 2.1 (p. 3)</i>		
1	SCLPEN	0	RW	SCL Pin Enable When set, the SCL pin of the I ² C is enabled.
0	SDAPEN	0	RW	SDA Pin Enable When set, the SDA pin of the I ² C is enabled.

16 USART - Universal Synchronous Asynchronous Receiver/Transmitter

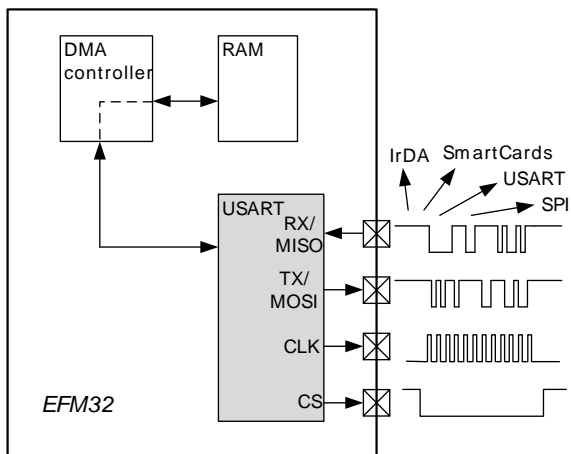
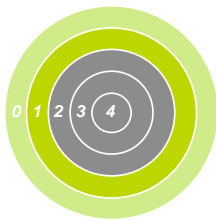

Quick Facts

What?

The USART handles high-speed UART, SPI-bus, SmartCards, and IrDA communication.

Why?

Serial communication is frequently used in embedded systems and the USART allows efficient communication with a wide range of external devices.

How?

The USART has a wide selection of operating modes, frame formats and baud rates. The multi-processor mode allows the USART to remain idle when not addressed. Triple buffering and DMA support makes high data-rates possible with minimal CPU intervention and it is possible to transmit and receive large frames while the MCU remains in EM1.

16.1 Introduction

The Universal Synchronous Asynchronous serial Receiver and Transmitter (USART) is a very flexible serial I/O module. It supports full duplex asynchronous UART communication as well as RS-485, SPI, MicroWire and 3-wire. It can also interface with ISO7816 SmartCards, and IrDA devices.

16.2 Features

- Asynchronous and synchronous (SPI) communication
- Full duplex and half duplex
- Separate TX/RX enable
- Separate receive / transmit 2-level buffers, with additional separate shift registers
- Programmable baud rate, generated as a fractional division from the peripheral clock ($\text{HFPERCLK}_{\text{USARTn}}$)
- Max bit-rate
 - SPI master mode, peripheral clock rate/2
 - SPI slave mode, peripheral clock rate/8
 - UART mode, peripheral clock rate/16, 8, 6, or 4
- Asynchronous mode supports
 - Majority vote baud-reception
 - False start-bit detection
 - Break generation/detection
 - Multi-processor mode
- Synchronous mode supports
 - All 4 SPI clock polarity/phase configurations
 - Master and slave mode
- Data can be transmitted LSB first or MSB first

- Configurable number of data bits, 4-16 (plus the parity bit, if enabled)
 - HW parity bit generation and check
- Configurable number of stop bits in asynchronous mode: 0.5, 1, 1.5, 2
- HW collision detection
- Multi-processor mode
- IrDA modulator on USART0
- SmartCard (ISO7816) mode
- Separate interrupt vectors for receive and transmit interrupts
- Loopback mode
 - Half duplex communication
 - Communication debugging

16.3 Functional Description

An overview of the USART module is shown in Figure 16.1 (p. 178) .

Figure 16.1. USART Overview

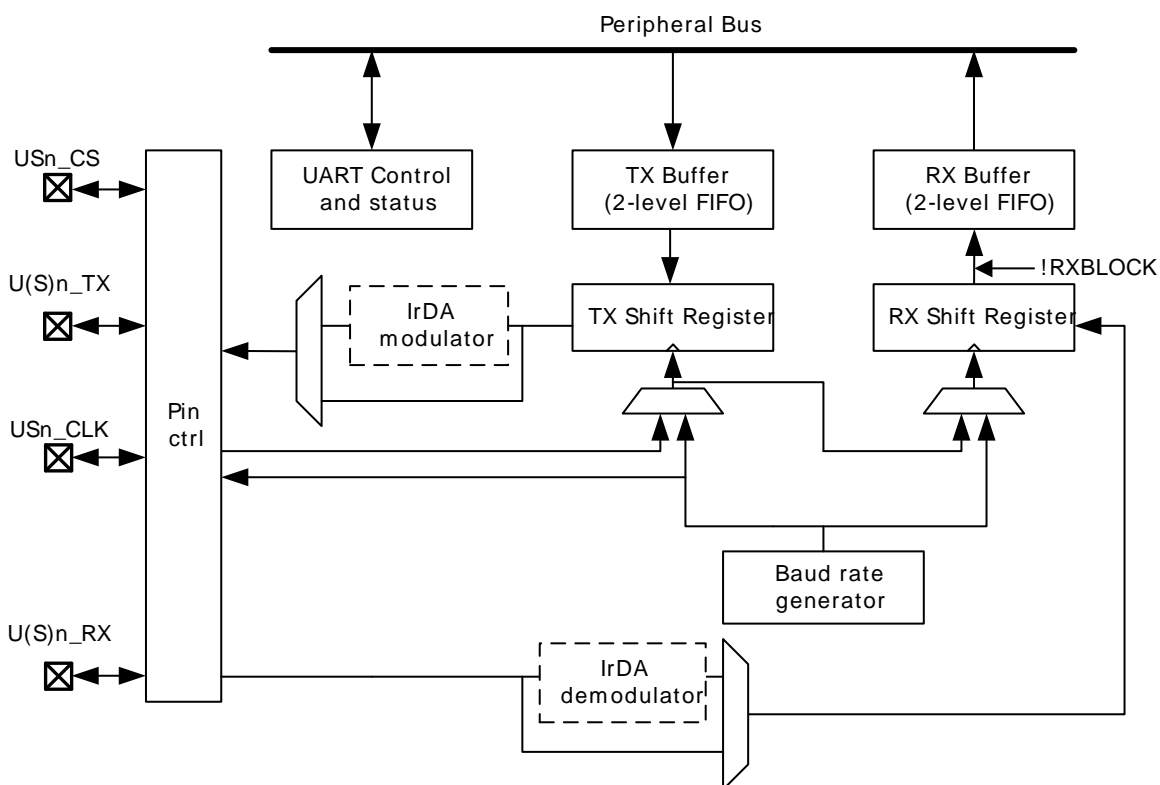

16.3.1 Modes of Operation

The USART operates in either asynchronous or synchronous mode.

In synchronous mode, a separate clock signal is transmitted with the data. This clock signal is generated by the bus master, and both the master and slave sample and transmit data according to this clock. Both master and slave modes are supported by the USART. The synchronous communication mode is compatible with the Serial Peripheral Interface Bus (SPI) standard.

In asynchronous mode, no separate clock signal is transmitted with the data on the bus. The USART receiver thus has to determine where to sample the data on the bus from the actual data. To make this possible, additional synchronization bits are added to the data when operating in asynchronous mode, resulting in a slight overhead.

Asynchronous or synchronous mode can be selected by configuring SYNC in USARTn_CTRL. The options are listed with supported protocols in Table 16.1 (p. 179) . Full duplex and half duplex communication is supported in both asynchronous and synchronous mode.

Table 16.1. USART Asynchronous vs. Synchronous Mode

SYNC	Communication Mode	Supported Protocols
0	Asynchronous	RS-232, RS-485 (w/external driver), IrDA, ISO 7816
1	Synchronous	SPI, MicroWire, 3-wire

Table 16.2 (p. 179) explains the functionality of the different USART pins when the USART operates in different modes. Pin functionality enclosed in square brackets is optional, and depends on additional configuration parameters. LOOPBK and MASTER are discussed in Section 16.3.2.5 (p. 187) and Section 16.3.3.3 (p. 194) respectively.

Table 16.2. USART Pin Usage

SYNC	LOOPBK	MASTER	Pin functionality			
			U(S)n_TX (MOSI)	U(S)n_RX (MISO)	USn_CLK	USn_CS
0	0	x	Data out	Data in	-	[Driver enable]
1	1	x	Data out/in	-	-	[Driver enable]
1	0	0	Data in	Data out	Clock in	Slave select
1	0	1	Data out	Data in	Clock out	[Auto slave select]
1	1	0	Data out/in	-	Clock in	Slave select
1	1	1	Data out/in	-	Clock out	[Auto slave select]

16.3.2 Asynchronous Operation

16.3.2.1 Frame Format

The frame format used in asynchronous mode consists of a set of data bits in addition to bits for synchronization and optionally a parity bit for error checking. A frame starts with one start-bit (S), where the line is driven low for one bit-period. This signals the start of a frame, and is used for synchronization. Following the start bit are 4 to 16 data bits and an optional parity bit. Finally, a number of stop-bits, where the line is driven high, end the frame. An example frame is shown in Figure 16.2 (p. 179) .

Figure 16.2. USART Asynchronous Frame Format

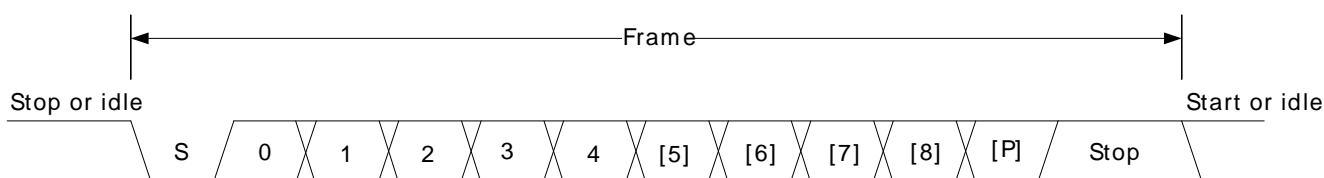

The number of data bits in a frame is set by DATABITS in USARTn_FRAME, see Table 16.3 (p. 180) , and the number of stop-bits is set by STOPBITS in USARTn_FRAME, see Table 16.4 (p. 180) . Whether or not a parity bit should be included, and whether it should be even or odd is defined by PARITY, also in USARTn_FRAME. For communication to be possible, all parties of an asynchronous transfer must agree on the frame format being used.

Table 16.3. USART Data Bits

DATA BITS [3:0]	Number of Data bits
0001	4
0010	5
0011	6
0100	7
0101	8 (Default)
0110	9
0111	10
1000	11
1001	12
1010	13
1011	14
1100	15
1101	16

Table 16.4. USART Stop Bits

STOP BITS [1:0]	Number of Stop bits
00	0.5
01	1 (Default)
10	1.5
11	2

The order in which the data bits are transmitted and received is defined by MSBF in USARTn_CTRL. When MSBF is cleared, data in a frame is sent and received with the least significant bit first. When it is set, the most significant bit comes first.

The frame format used by the transmitter can be inverted by setting TXINV in USARTn_CTRL, and the format expected by the receiver can be inverted by setting RXINV in USARTn_CTRL. These bits affect the entire frame, not only the data bits. An inverted frame has a low idle state, a high start-bit, inverted data and parity bits, and low stop-bits.

16.3.2.1.1 Parity bit Calculation and Handling

When parity bits are enabled, hardware automatically calculates and inserts any parity bits into outgoing frames, and verifies the received parity bits in incoming frames. This is true for both asynchronous and synchronous modes, even though it is mostly used in asynchronous communication. The possible parity modes are defined in Table 16.5 (p. 181). When even parity is chosen, a parity bit is inserted to make the number of high bits (data + parity) even. If odd parity is chosen, the parity bit makes the total number of high bits odd.

Table 16.5. USART Parity Bits

STOP BITS [1:0]	Description
00	No parity bit (Default)
01	Reserved
10	Even parity
11	Odd parity

16.3.2.2 Clock Generation

The USART clock defines the transmission and reception data rate. When operating in asynchronous mode, the baud rate (bit-rate) is given by Equation 16.1 (p. 181)

USART Baud Rate

$$br = f_{H\text{FPERCLK}} / (\text{oversample} \times (1 + \text{USARTn_CLKDIV}/256)) \tag{16.1}$$

where $f_{H\text{FPERCLK}}$ is the peripheral clock ($H\text{FPERCLK}_{\text{USARTn}}$) frequency and oversample is the oversampling rate as defined by OVS in USARTn_CTRL , see Table 16.6 (p. 181) .

Table 16.6. USART Oversampling

OVS [1:0]	oversample
00	16
01	8
10	6
11	4

The USART has a fractional clock divider to allow the USART clock to be controlled more accurately than what is possible with a standard integral divider.

The clock divider used in the USART is a 15-bit value, with a 13-bit integral part and a 2-bit fractional part. The fractional part is configured in the two LSBs of DIV in USART_CLKDIV . The lowest achievable baud rate at 32 MHz is about 244 bauds/sec.

Fractional clock division is implemented by distributing the selected fraction over four baud periods. The fractional part of the divider tells how many of these periods should be extended by one peripheral clock cycle.

Given a desired baud rate br_{desired} , the clock divider USARTn_CLKDIV can be calculated by using Equation 16.2 (p. 181) :

USART Desired Baud Rate

$$\text{USARTn_CLKDIV} = 256 \times (f_{H\text{FPERCLK}} / (\text{oversample} \times br_{\text{desired}}) - 1) \tag{16.2}$$

Table 16.7 (p. 182) shows a set of desired baud rates and how accurately the USART is able to generate these baud rates when running at a 4 MHz peripheral clock, using 16x or 8x oversampling.

Table 16.7. USART Baud Rates @ 4MHz Peripheral Clock

Desired baud rate [baud/s]	USARTn_OVS =00			USARTn_OVS =01		
	USARTn_CLKDIV/256	Actual baud rate [baud/s]	Error %	USARTn_CLKDIV/256	Actual baud rate [baud/s]	Error %
600	415,75	599,88	-0,02	832,25	600,06	0,01
1200	207,25	1200,48	0,04	415,75	1199,76	-0,02
2400	103,25	2398,082	-0,08	207,25	2400,96	0,04
4800	51	4807,692	0,16	103,25	4796,163	-0,08
9600	25	9615,385	0,16	51	9615,385	0,16
14400	16,25	14492,75	0,64	33,75	14388,49	-0,08
19200	12	19230,77	0,16	25	19230,77	0,16
28800	7,75	28571,43	-0,79	16,25	28985,51	0,64
38400	5,5	38461,54	0,16	12	38461,54	0,16
57600	3,25	58823,53	2,12	7,75	57142,86	-0,79
76800	2,25	76923,08	0,16	5,5	76923,08	0,16
115200	1,25	111111,1	-3,55	3,25	117647,1	2,12
230400	0	250000	8,51	1,25	222222,2	-3,55

16.3.2.3 Data Transmission

Asynchronous data transmission is initiated by writing data to the transmit buffer using one of the methods described in Section 16.3.2.3.1 (p. 182). When the transmission shift register is empty and ready for new data, a frame from the transmit buffer is loaded into the shift register, and if the transmitter is enabled, transmission begins. When the frame has been transmitted, a new frame is loaded into the shift register if available, and transmission continues. If the transmit buffer is empty, the transmitter goes to an idle state, waiting for a new frame to become available.

Transmission is enabled through the command register USARTn_CMD by setting TXEN, and disabled by setting TXDIS in the same command register. When the transmitter is disabled using TXDIS, any ongoing transmission is aborted, and any frame currently being transmitted is discarded. When disabled, the TX output goes to an idle state, which by default is a high value. Whether or not the transmitter is enabled at a given time can be read from TXENS in USARTn_STATUS.

When the USART transmitter is enabled and there is no data in the transmit shift register or transmit buffer, the TXC flag in USARTn_STATUS and the TXC interrupt flag in USARTn_IF are set, signaling that the transmitter is idle. The TXC status flag is cleared when a new frame becomes available for transmission, but the TXC interrupt flag must be cleared by software.

16.3.2.3.1 Transmit Buffer Operation

The transmit-buffer is a 2-level FIFO buffer. A frame can be loaded into the buffer by writing to USARTn_TXDATA, USARTn_TXDATAx, USARTn_TXDOUBLE or USARTn_TXDOUBLEX. Using USARTn_TXDATA allows 8 bits to be written to the buffer, while using USARTn_TXDOUBLE will write 2 frames of 8 bits to the buffer. If 9-bit frames are used, the 9th bit of the frames will in these cases be set to the value of BIT8DV in USARTn_CTRL.

To set the 9th bit directly and/or use transmission control, USARTn_TXDATAx and USARTn_TXDOUBLEX must be used. USARTn_TXDATAx allows 9 data bits to be written, as well as a set of control bits regarding the transmission of the written frame. Every frame in the buffer is stored with 9 data bits and additional transmission control bits. USARTn_TXDOUBLEX allows two

frames, complete with control bits to be written at once. When data is written to the transmit buffer using USARTn_TXDATA and USARTn_TXDOUBLEX, the 9th bit(s) written to these registers override the value in BIT8DV in USARTn_CTRL, and alone define the 9th bits that are transmitted if 9-bit frames are used. Figure 16.3 (p. 183) shows the basics of the transmit buffer when DATABITS in USARTn_FRAME is configured to less than 10 bits.

Figure 16.3. USART Transmit Buffer Operation

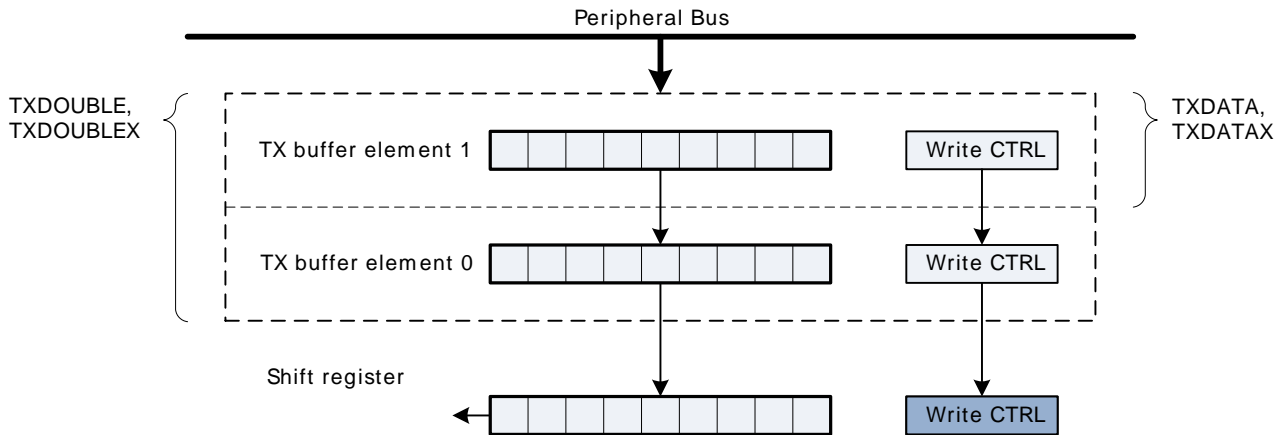

When writing more frames to the transmit buffer than there is free space for, the TXOF interrupt flag in USARTn_IF will be set, indicating the overflow. The data already in the transmit buffer is preserved in this case, and no data is written.

In addition to the interrupt flag TXC in USARTn_IF and status flag TXC in USARTn_STATUS which are set when the transmitter is idle, TXBL in USARTn_STATUS and the TXBL interrupt flag in USARTn_IF are used to indicate the level of the transmit buffer. TXBIL in USARTn_CTRL controls the level at which these bits are set. If TXBIL is cleared, they are set whenever the transmit buffer becomes empty, and if TXBIL is set, they are set whenever the transmit buffer goes from full to half-full or empty. Both the TXBL status flag and the TXBL interrupt flag are cleared automatically when their condition becomes false.

The transmit buffer, including the transmit shift register can be cleared by setting CLEARTX in USARTn_CMD. This will prevent the USART from transmitting the data in the buffer and shift register, and will make them available for new data. Any frame currently being transmitted will not be aborted. Transmission of this frame will be completed.

16.3.2.3.2 Frame Transmission Control

The transmission control bits, which can be written using USARTn_TXDATA and USARTn_TXDOUBLEX, affect the transmission of the written frame. The following options are available:

- **Generate break:** By setting TXBREAK, the output will be held low during the stop-bit period to generate a framing error. A receiver that supports break detection detects this state, allowing it to be used e.g. for framing of larger data packets. The line is driven high before the next frame is transmitted so the next start condition can be identified correctly by the recipient. Continuous breaks lasting longer than a USART frame are thus not supported by the USART. GPIO can be used for this.
- **Disable transmitter after transmission:** If TXDISAT is set, the transmitter is disabled after the frame has been fully transmitted.
- **Enable receiver after transmission:** If RXENAT is set, the receiver is enabled after the frame has been fully transmitted. It is enabled in time to detect a start-bit directly after the last stop-bit has been transmitted.
- **Unblock receiver after transmission:** If UBRXAT is set, the receiver is unblocked and RXBLOCK is cleared after the frame has been fully transmitted.
- **Tristate transmitter after transmission:** If TXTRIAT is set, TXTRI is set after the frame has been fully transmitted, tristating the transmitter output. Tristating of the output can also be performed automatically by setting AUTOTRI. If AUTOTRI is set TXTRI is always read as 0.

Note

When in SmartCard mode with repeat enabled, none of the actions, except generate break, will be performed until the frame is transmitted without failure. Generation of a break in SmartCard mode with repeat enabled will cause the USART to detect a NACK on every frame.

16.3.2.4 Data Reception

Data reception is enabled by setting RXEN in USARTn_CMD. When the receiver is enabled, it actively samples the input looking for a transition from high to low indicating the start baud of a new frame. When a start baud is found, reception of the new frame begins if the receive shift register is empty and ready for new data. When the frame has been received, it is pushed into the receive buffer, making the shift register ready for another frame of data, and the receiver starts looking for another start baud. If the receive buffer is full, the received frame remains in the shift register until more space in the receive buffer is available. If an incoming frame is detected while both the receive buffer and the receive shift register are full, the data in the shift register is overwritten, and the RXOF interrupt flag in USARTn_IF is set to indicate the buffer overflow.

The receiver can be disabled by setting the command bit RXDIS in USARTn_CMD. Any frame currently being received when the receiver is disabled is discarded. Whether or not the receiver is enabled at a given time can be read out from RXENS in USARTn_STATUS.

16.3.2.4.1 Receive Buffer Operation

When data becomes available in the receive buffer, the RXDATAV flag in USARTn_STATUS, and the RXDATAV interrupt flag in USARTn_IF are set, and when the buffer becomes full, RXFULL in USARTn_STATUS and the RXFULL interrupt flag in USARTn_IF are set. The status flags RXDATAV and RXFULL are automatically cleared by hardware when their condition is no longer true. This also goes for the RXDATAV interrupt flag, but the RXFULL interrupt flag must be cleared by software. When the RXFULL flag is set, notifying that the buffer is full, space is still available in the receive shift register for one more frame.

Data can be read from the receive buffer in a number of ways. USARTn_RXDATA gives access to the 8 least significant bits of the received frame, and USARTn_RXDOUBLE makes it possible to read the 8 least significant bits of two frames at once, pulling two frames from the buffer. To get access to the 9th, most significant bit, USARTn_RXDATA9 must be used. This register also contains status information regarding the frame. USARTn_RXDOUBLE9 can be used to get two frames complete with the 9th bits and status bits.

When a frame is read from the receive buffer using USARTn_RXDATA or USARTn_RXDATA9, the frame is pulled out of the buffer, making room for a new frame. USARTn_RXDOUBLE and USARTn_RXDOUBLE9 pull two frames out of the buffer. If an attempt is done to read more frames from the buffer than what is available, the RXUF interrupt flag in USARTn_IF is set to signal the underflow, and the data read from the buffer is undefined.

Frames can be read from the receive buffer without removing the data by using USARTn_RXDATA9P and USARTn_RXDOUBLE9P. USARTn_RXDATA9P gives access the first frame in the buffer with status bits, while USARTn_RXDOUBLE9P gives access to both frames with status bits. The data read from these registers when the receive buffer is empty is undefined. If the receive buffer contains one valid frame, the first frame in USARTn_RXDOUBLE9P will be valid. No underflow interrupt is generated by a read using these registers, i.e. RXUF in USARTn_IF is never set as a result of reading from USARTn_RXDATA9P or USARTn_RXDOUBLE9P.

The basic operation of the receive buffer when DATABITS in USARTn_FRAME is configured to less than 10 bits is shown in Figure 16.4 (p. 185) .

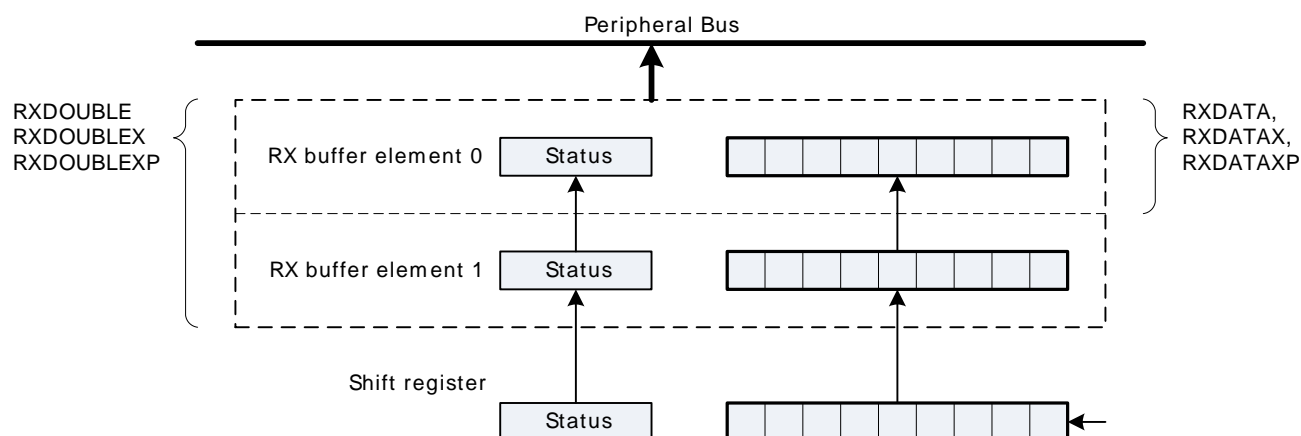
Figure 16.4. USART Receive Buffer Operation

The receive buffer, including the receive shift register can be cleared by setting CLEARRX in USARTn_CMD. Any frame currently being received will not be discarded.

16.3.2.4.2 Blocking Incoming Data

When using hardware frame recognition, as detailed in Section 16.3.2.8 (p. 190) and Section 16.3.2.9 (p. 191), it is necessary to be able to let the receiver sample incoming frames without passing the frames to software by loading them into the receive buffer. This is accomplished by blocking incoming data.

Incoming data is blocked as long as RXBLOCK in USARTn_STATUS is set. When blocked, frames received by the receiver will not be loaded into the receive buffer, and software is not notified by the RXDATAV flag in USARTn_STATUS or the RXDATAV interrupt flag in USARTn_IF at their arrival. For data to be loaded into the receive buffer, RXBLOCK must be cleared in the instant a frame is fully received by the receiver. RXBLOCK is set by setting RXBLOCKEN in USARTn_CMD and disabled by setting RXBLOCKDIS also in USARTn_CMD. There is one exception where data is loaded into the receive buffer even when RXBLOCK is set. This is when an address frame is received when operating in multi-processor mode. See Section 16.3.2.8 (p. 190) for more information.

Frames received containing framing or parity errors will not result in the FERR and PERR interrupt flags in USARTn_IF being set while RXBLOCK in USARTn_STATUS is set. Hardware recognition is not applied to these erroneous frames, and they are silently discarded.

Note

If a frame is received while RXBLOCK in USARTn_STATUS is cleared, but stays in the receive shift register because the receive buffer is full, the received frame will be loaded into the receive buffer when space becomes available even if RXBLOCK is set at that time.

The overflow interrupt flag RXOF in USARTn_IF will be set if a frame in the receive shift register, waiting to be loaded into the receive buffer is overwritten by an incoming frame even though RXBLOCK in USARTn_STATUS is set.

16.3.2.4.3 Clock Recovery and Filtering

The receiver samples the incoming signal at a rate 16, 8, 6 or 4 times higher than the given baud rate, depending on the oversampling mode given by OVS in USARTn_CTRL. Lower oversampling rates make higher baud rates possible, but give less room for errors.

When a high-to-low transition is registered on the input while the receiver is idle, this is recognized as a start-bit, and the baud rate generator is synchronized with the incoming frame.

For oversampling modes 16, 8 and 6, every bit in the incoming frame is sampled three times to gain a level of noise immunity. These samples are aimed at the middle of the bit-periods, as visualized in

Figure 16.5 (p. 186) . With OVS=0 in USARTn_CTRL, the start and data bits are thus sampled at locations 8, 9 and 10 in the figure, locations 4, 5 and 6 for OVS=1 and locations 3, 4, and 5 for OVS=2. The value of a sampled bit is determined by majority vote. If two or more of the three bit-samples are high, the resulting bit value is high. If the majority is low, the resulting bit value is low.

Majority vote is used for all oversampling modes except 4x oversampling. In this mode, a single sample is taken at position 3 as shown in Figure 16.5 (p. 186) .

If the value of the start bit is found to be high, the reception of the frame is aborted, filtering out false start bits possibly generated by noise on the input.

Figure 16.5. USART Sampling of Start and Data Bits

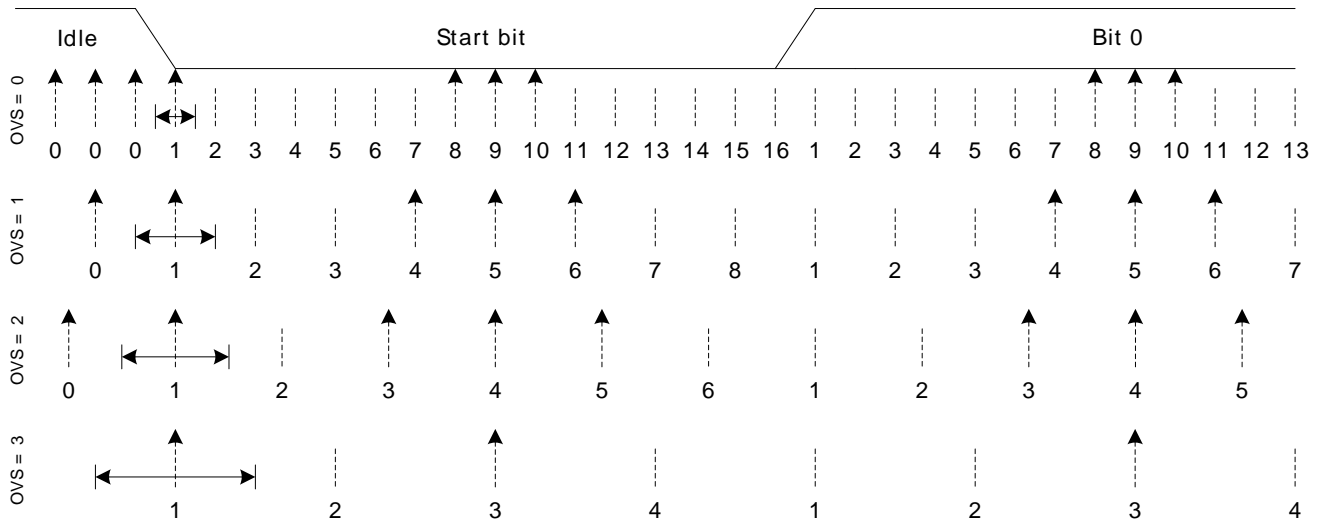

If the baud rate of the transmitter and receiver differ, the location each bit is sampled will be shifted towards the previous or next bit in the frame. This is acceptable for small errors in the baud rate, but for larger errors, it will result in transmission errors.

When the number of stop bits is 1 or more, stop bits are sampled like the start and data bits as seen in Figure 16.6 (p. 186) . When a stop bit has been detected by sampling at positions 8, 9 and 10 for normal mode, or 4, 5 and 6 for smart mode, the USART is ready for a new start bit. As seen in Figure 16.6 (p. 186) , a stop-bit of length 1 normally ends at c, but the next frame will be received correctly as long as the start-bit comes after position a for OVS=0 and OVS=3, and b for OVS=1 and OVS=2.

Figure 16.6. USART Sampling of Stop Bits when Number of Stop Bits are 1 or More

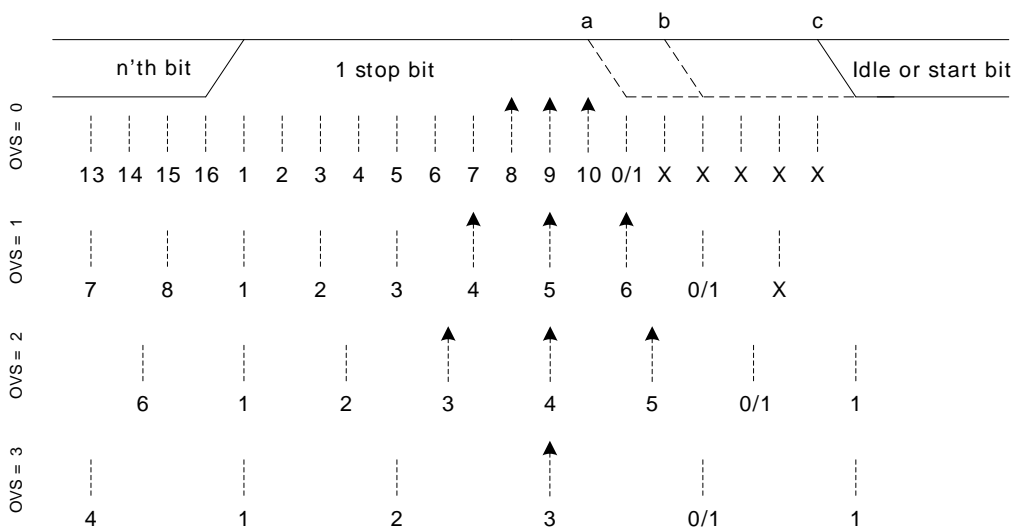

When working with stop bit lengths of half a baud period, the above sampling scheme no longer suffices. In this case, the stop-bit is not sampled, and no framing error is generated in the receiver if the stop-bit is not generated. The line must still be driven high before the next start bit however for the USART to successfully identify the start bit.

16.3.2.4.4 Parity Error

When parity bits are enabled, a parity check is automatically performed on incoming frames. When a parity error is detected in an incoming frame, the data parity error bit PERR in the frame is set, as well as the interrupt flag PERR in USARTn_IF. Frames with parity errors are loaded into the receive buffer like regular frames.

PERR can be accessed by reading the frame from the receive buffer using the USARTn_RXDATA, USARTn_RXDATAEXP, USARTn_RXDOUBLEX or USARTn_RXDOUBLEXP registers.

If ERRSTX in USARTn_CTRL is set, the transmitter is disabled on received parity and framing errors. If ERRSRX in USARTn_CTRL is set, the receiver is disabled on parity and framing errors.

16.3.2.4.5 Framing Error and Break Detection

A framing error is the result of an asynchronous frame where the stop bit was sampled to a value of 0. This can be the result of noise and baud rate errors, but can also be the result of a break generated by the transmitter on purpose.

When a framing error is detected in an incoming frame, the framing error bit FERR in the frame is set. The interrupt flag FERR in USARTn_IF is also set. Frames with framing errors are loaded into the receive buffer like regular frames.

FERR can be accessed by reading the frame from the receive buffer using the USARTn_RXDATA, USARTn_RXDATAEXP, USARTn_RXDOUBLEX or USARTn_RXDOUBLEXP registers.

If ERRSTX in USARTn_CTRL is set, the transmitter is disabled on parity and framing errors. If ERRSRX in USARTn_CTRL is set, the receiver is disabled on parity and framing errors.

16.3.2.5 Local Loopback

The USART receiver samples U(S)n_RX by default, and the transmitter drives U(S)n_TX by default. This is not the only option however. When LOOPBK in USARTn_CTRL is set, the receiver is connected to the U(S)n_TX pin as shown in Figure 16.7 (p. 187). This is useful for debugging, as the USART can receive the data it transmits, but it is also used to allow the USART to read and write to the same pin, which is required for some half duplex communication modes. In this mode, the U(S)n_TX pin must be enabled as an output in the GPIO.

Figure 16.7. USART Local Loopback

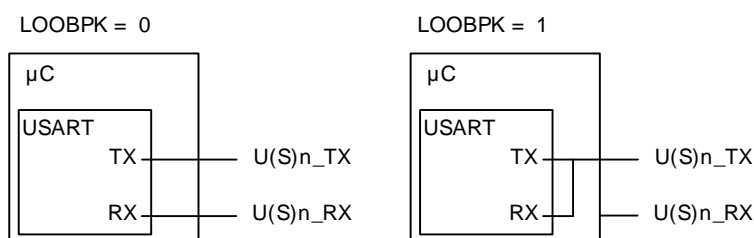

16.3.2.6 Asynchronous Half Duplex Communication

When doing full duplex communication, two data links are provided, making it possible for data to be sent and received at the same time. In half duplex mode, data is only sent in one direction at a time. There are several possible half duplex setups, as described in the following sections.

16.3.2.6.1 Single Data-link

In this setup, the USART both receives and transmits data on the same pin. This is enabled by setting LOOPBK in USARTn_CTRL, which connects the receiver to the transmitter output. Because they are both connected to the same line, it is important that the USART transmitter does not drive the line when receiving data, as this would corrupt the data on the line.

When communicating over a single data-link, the transmitter must thus be tristated whenever not transmitting data. This is done by setting the command bit TXTRIEN in USARTn_CMD, which tristates the transmitter. Before transmitting data, the command bit TXTRIDIS, also in USARTn_CMD, must be set to enable transmitter output again. Whether or not the output is tristated at a given time can be read from TXTRI in USARTn_STATUS. If TXTRI is set when transmitting data, the data is shifted out of the shift register, but is not put out on U(S)n_TX.

When operating a half duplex data bus, it is common to have a bus master, which first transmits a request to one of the bus slaves, then receives a reply. In this case, the frame transmission control bits, which can be set by writing to USARTn_TXDATA, can be used to make the USART automatically disable transmission, tristate the transmitter and enable reception when the request has been transmitted, making it ready to receive a response from the slave.

Tristating the transmitter can also be performed automatically by the USART by using AUTOTRI in USARTn_CTRL. When AUTOTRI is set, the USART automatically tristates U(S)n_TX whenever the transmitter is idle, and enables transmitter output when the transmitter goes active. If AUTOTRI is set TXTRI is always read as 0.

Note

Another way to tristate the transmitter is to enable wired-and or wired-or mode in GPIO. For wired-and mode, outputting a 1 will be the same as tristating the output, and for wired-or mode, outputting a 0 will be the same as tristating the output. This can only be done on buses with a pull-up or pull-down resistor respectively.

16.3.2.6.2 Single Data-link with External Driver

Some communication schemes, such as RS-485 rely on an external driver. Here, the driver has an extra input which enables it, and instead of tristating the transmitter when receiving data, the external driver must be disabled.

This can be done manually by assigning a GPIO to turn the driver on or off, or it can be handled automatically by the USART. If AUTOCS in USARTn_CTRL is set, the USn_CS output is automatically activated one baud period before the transmitter starts transmitting data, and deactivated when the last bit has been transmitted and there is no more data in the transmit buffer to transmit, or the transmitter becomes disabled. This feature can be used to turn the external driver on when transmitting data, and turn it off when the data has been transmitted.

Figure 16.8 (p. 188) shows an example configuration where USn_CS is used to automatically enable and disable an external driver.

Figure 16.8. USART Half Duplex Communication with External Driver

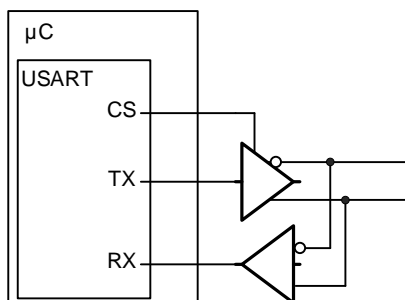

The USn_CS output is active low by default, but its polarity can be changed with CSINV in USARTn_CTRL. AUTOCS works regardless of which mode the USART is in, so this functionality can also be used for automatic chip/slave select when in synchronous mode (e.g. SPI).

16.3.2.6.3 Two Data-links

Some limited devices only support half duplex communication even though two data links are available. In this case software is responsible for making sure data is not transmitted when incoming data is expected.

16.3.2.7 Large Frames

As each frame in the transmit and receive buffers holds a maximum of 9 bits, both the elements in the buffers are combined when working with USART-frames of 10 or more data bits.

To transmit such a frame, at least two elements must be available in the transmit buffer. If only one element is available, the USART will wait for the second element before transmitting the combined frame. Both the elements making up the frame are consumed when transmitting such a frame.

When using large frames, the 9th bits in the buffers are unused. For an 11 bit frame, the 8 least significant bits are thus taken from the first element in the buffer, and the 3 remaining bits are taken from the second element as shown in Figure 16.9 (p. 189) . The first element in the transmit buffer, i.e. element 0 in Figure 16.9 (p. 189) is the first element written to the FIFO, or the least significant byte when writing two bytes at a time using USARTn_TXDOUBLE.

Figure 16.9. USART Transmission of Large Frames

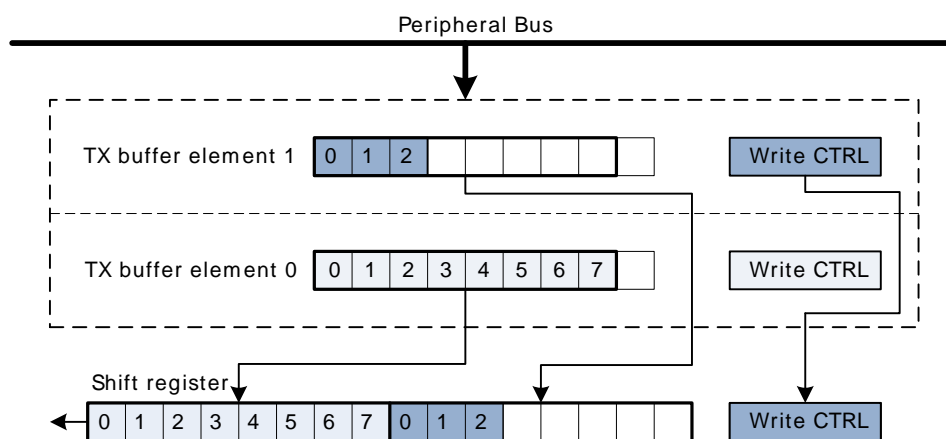

As shown in Figure 16.9 (p. 189) , frame transmission control bits are taken from the second element in FIFO.

The two buffer elements can be written at the same time using the USARTn_TXDOUBLE or USARTn_TXDOUBLEX register. The TXDATAx0 bitfield then refers to buffer element 0, and TXDATAx1 refers to buffer element 1.

Figure 16.10. USART Transmission of Large Frames, MSBF

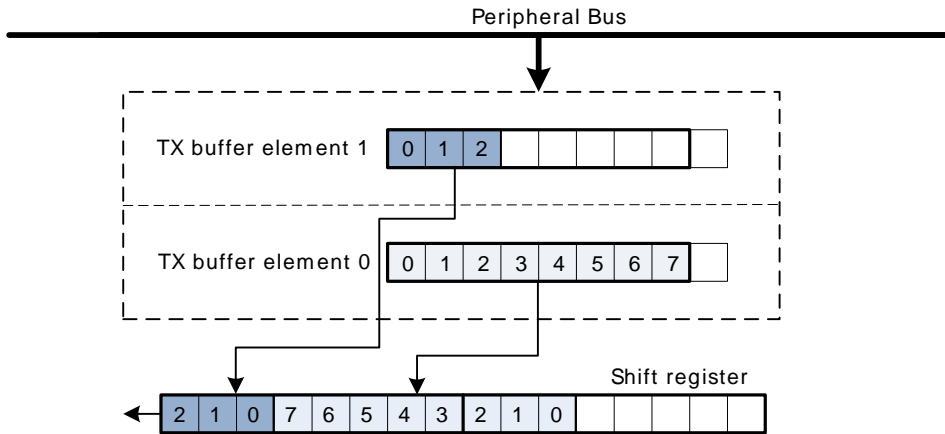
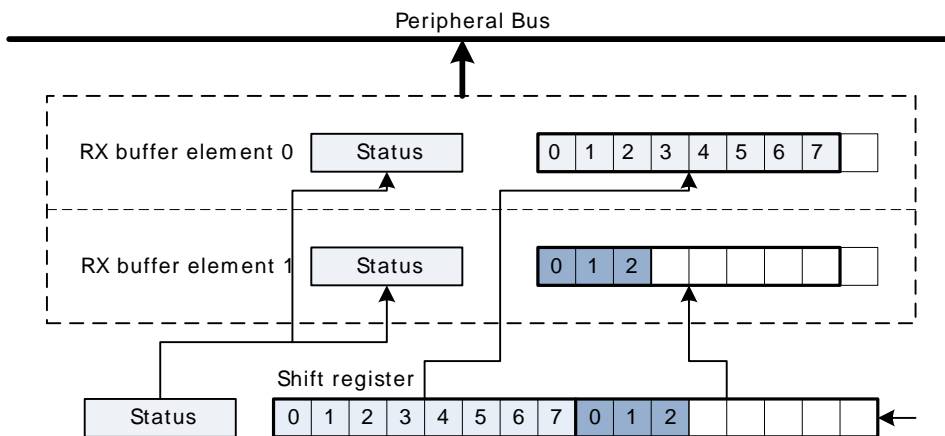

Figure 16.10 (p. 190) illustrates the order of the transmitted bits when an 11 bit frame is transmitted with MSBF set. If MSBF is set and the frame is smaller than 10 bits, only the contents of transmit buffer 0 will be transmitted.

When receiving a large frame, BYTESWAP in USARTn_CTRL determines the order the way the large frame is split into the two buffer elements. If BYTESWAP is cleared, the least significant 8 bits of the received frame are loaded into the first element of the receive buffer, and the remaining bits are loaded into the second element, as shown in Figure 16.11 (p. 190) . The first byte read from the buffer thus contains the 8 least significant bits. Set BYTESWAP to reverse the order.

The status bits are loaded into both elements of the receive buffer. The frame is not moved from the receive shift register before there are two free spaces in the receive buffer.

Figure 16.11. USART Reception of Large Frames



The two buffer elements can be read at the same time using the USARTn_RXDOUBLE or USARTn_RXDOUBLEX register. RXDATA0 then refers to buffer element 0 and RXDATA1 refers to buffer element 1.

Large frames can be used in both asynchronous and synchronous modes.

16.3.2.8 Multi-Processor Mode

To simplify communication between multiple processors, the USART supports a special multi-processor mode. In this mode the 9th data bit in each frame is used to indicate whether the content of the remaining 8 bits is data or an address.

When multi-processor mode is enabled, an incoming 9-bit frame with the 9th bit equal to the value of MPAB in USARTn_CTRL is identified as an address frame. When an address frame is detected, the

MPAF interrupt flag in USARTn_IF is set, and the address frame is loaded into the receive register. This happens regardless of the value of RXBLOCK in USARTn_STATUS.

Multi-processor mode is enabled by setting MPM in USARTn_CTRL, and the value of the 9th bit in address frames can be set in MPAB. Note that the receiver must be enabled for address frames to be detected. The receiver can be blocked however, preventing data from being loaded into the receive buffer while looking for address frames.

Example 16.1 (p. 191) explains basic usage of the multi-processor mode:

Example 16.1. USART Multi-processor Mode Example

1. All slaves enable multi-processor mode and, enable and block the receiver. They will now not receive data unless it is an address frame. MPAB in USARTn_CTRL is set to identify frames with the 9th bit high as address frames.
2. The master sends a frame containing the address of a slave and with the 9th bit set
3. All slaves receive the address frame and get an interrupt. They can read the address from the receive buffer. The selected slave unblocks the receiver to start receiving data from the master.
4. The master sends data with the 9th bit cleared
5. Only the slave with RX enabled receives the data. When transmission is complete, the slave blocks the receiver and waits for a new address frame.

When a slave has received an address frame and wants to receive the following data, it must make sure the receiver is unblocked before the next frame has been completely received in order to prevent data loss.

BIT8DV in USARTn_CTRL can be used to specify the value of the 9th bit without writing to the transmit buffer with USARTn_TXDATA or USARTn_TXDOUBLEX, giving higher efficiency in multi-processor mode, as the 9th bit is only set when writing address frames, and 8-bit writes to the USART can be used when writing the data frames.

16.3.2.9 Collision Detection

The USART supports a basic form of collision detection. When the receiver is connected to the output of the transmitter, either by using the LOOPBK bit in USARTn_CTRL or through an external connection, this feature can be used to detect whether data transmitted on the bus by the USART did get corrupted by a simultaneous transmission by another device on the bus.

For collision detection to be enabled, CCEN in USARTn_CTRL must be set, and the receiver enabled. The data sampled by the receiver is then continuously compared with the data output by the transmitter. If they differ, the CCF interrupt flag in USARTn_IF is set. The collision check includes all bits of the transmitted frames. The CCF interrupt flag is set once for each bit sampled by the receiver that differs from the bit output by the transmitter. When the transmitter output is disabled, i.e. the transmitter is tristated, collisions are not registered.

16.3.2.10 SmartCard Mode

In SmartCard mode, the USART supports the ISO 7816 I/O line T0 mode. With exception of the stop-bits (guard time), the 7816 data frame is equal to the regular asynchronous frame. In this mode, the receiver pulls the line low for one baud, half a baud into the guard time to indicate a parity error. This NAK can for instance be used by the transmitter to re-transmit the frame. SmartCard mode is a half duplex asynchronous mode, so the transmitter must be tristated whenever not transmitting data.

To enable SmartCard mode, set SCMODE in USARTn_CTRL, set the number of databits in a frame to 8, and configure the number of stopbits to 1.5 by writing to STOPBITS in USARTn_FRAME.

The SmartCard mode relies on half duplex communication on a single line, so for it to work, both the receiver and transmitter must work on the same line. This can be achieved by setting LOOPBK in

USARTn_CTRL or through an external connection. The TX output should be configured as open-drain in the GPIO module.

When no parity error is identified by the receiver, the data frame is as shown in Figure 16.12 (p. 192) . The frame consists of 8 data bits, a parity bit, and 2 stop bits. The transmitter does not drive the output line during the guard time.

Figure 16.12. USART ISO 7816 Data Frame Without Error

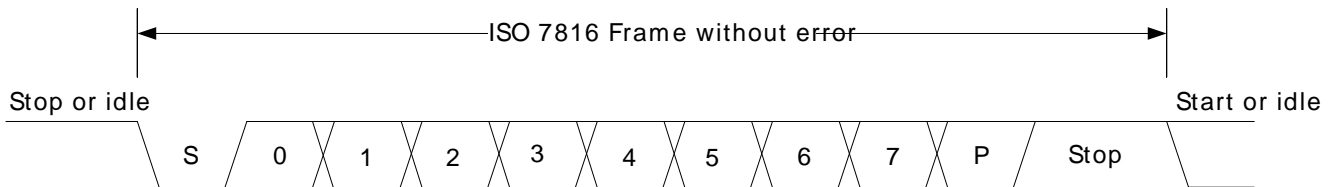

If a parity error is detected by the receiver, it pulls the line I/O line low after half a stop bit, see Figure 16.13 (p. 192) . It holds the line low for one bit-period before it releases the line. In this case, the guard time is extended by one bit period before a new transmission can start, resulting in a total of 3 stop bits.

Figure 16.13. USART ISO 7816 Data Frame With Error

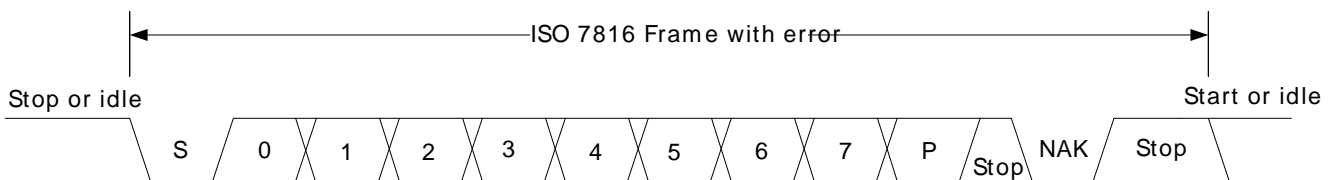

On a parity error, the NAK is generated by hardware. The NAK generated by the receiver is sampled as the stop-bit of the frame. Because of this, parity errors when in SmartCard mode are reported with both a parity error and a framing error.

When transmitting a T0 frame, the USART receiver on the transmitting side samples position 16, 17 and 18 in the stop-bit to detect the error signal when in 16x oversampling mode as shown in Figure 16.14 (p. 193) . Sampling at this location places the stop-bit sample in the middle of the bit-period used for the error signal (NAK).

If a NAK is transmitted by the receiver, it will thus appear as a framing error at the transmitter, and the FERR interrupt flag in USARTn_IF will be set. If SCRETRANS USARTn_CTRL is set, the transmitter will automatically retransmit a NACK'ed frame. The transmitter will retransmit the frame until it is ACK'ed by the receiver. This only works when the number of databits in a frame is configured to 8.

Set SKIPPERF in USARTn_CTRL to make the receiver discard frames with parity errors. The PERR interrupt flag in USARTn_IF is set when a frame is discarded because of a parity error.

Figure 16.14. USART SmartCard Stop Bit Sampling

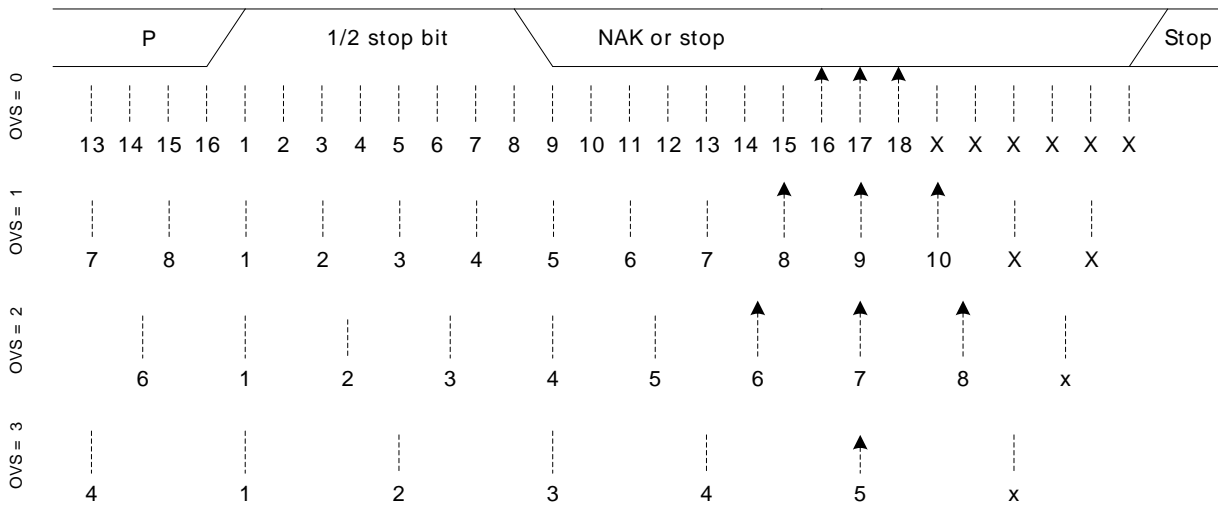

For communication with a SmartCard, a clock signal needs to be generated for the card. This clock output can be generated using one of the timers. See the ISO 7816 specification for more info on this clock signal.

SmartCard T1 mode is also supported. The T1 frame format used is the same as the asynchronous frame format with parity bit enabled and one stop bit. The USART must then be configured to operate in asynchronous half duplex mode.

16.3.3 Synchronous Operation

Most of the features in asynchronous mode are available in synchronous mode. Multi-processor mode can be enabled for 9-bit frames, loopback is available and collision detection can be performed.

16.3.3.1 Frame Format

The frames used in synchronous mode need no start and stop bits since a single clock is available to all parts participating in the communication. Parity bits cannot be used in synchronous mode.

The USART supports frame lengths of 4 to 16 bits per frame. Larger frames can be simulated by transmitting multiple smaller frames, i.e. a 22 bit frame can be sent using two 11-bit frames, and a 21 bit frame can be generated by transmitting three 7-bit frames. The number of bits in a frame is set using DATABITS in USARTn_FRAME.

The frames in synchronous mode are by default transmitted with the least significant bit first like in asynchronous mode. The bit-order can be reversed by setting MSBF in USARTn_CTRL.

The frame format used by the transmitter can be inverted by setting TXINV in USARTn_CTRL, and the format expected by the receiver can be inverted by setting RXINV, also in USARTn_CTRL.

16.3.3.2 Clock Generation

The bit-rate in synchronous mode is given by Equation 16.3 (p. 193). As in the case of asynchronous operation, the clock division factor have a 13-bit integral part and a 2-bit fractional part.

USART Synchronous Mode Bit Rate

$$br = f_{HPPERCLK} / (2 \times (1 + USARTn_CLKDIV/256)) \tag{16.3}$$

Given a desired baud rate brdesired, the clock divider USARTn_CLKDIV can be calculated using Equation 16.4 (p. 193)

USART Synchronous Mode Clock Division Factor

$$\text{USARTn_CLKDIV} = 256 \times (f_{\text{HFPERCLK}} / (2 \times \text{br}_{\text{desired}}) - 1) \tag{16.4}$$

When the USART operates in master mode, the highest possible bit rate is half the peripheral clock rate. When operating in slave mode however, the highest bit rate is an eighth of the peripheral clock:

- Master mode: $\text{br}_{\text{max}} = f_{\text{HFPERCLK}}/2$
- Slave mode: $\text{br}_{\text{max}} = f_{\text{HFPERCLK}}/8$

On every clock edge data on the data lines, MOSI and MISO, is either set up or sampled. When CLKPHA in USARTn_CTRL is cleared, data is sampled on the leading clock edge and set-up is done on the trailing edge. If CLKPHA is set however, data is set-up on the leading clock edge, and sampled on the trailing edge. In addition to this, the polarity of the clock signal can be changed by setting CLKPOL in USARTn_CTRL, which also defines the idle state of the clock. This results in four different modes which are summarized in Table 16.8 (p. 194). Figure 16.15 (p. 194) shows the resulting timing of data set-up and sampling relative to the bus clock.

Table 16.8. USART SPI Modes

SPI mode	CLKPOL	CLKPHA	Leading edge	Trailing edge
0	0	0	Rising, sample	Falling, set-up
1	0	1	Rising, set-up	Falling, sample
2	1	0	Falling, sample	Rising, set-up
3	1	1	Falling, set-up	Rising, sample

Figure 16.15. USART SPI Timing

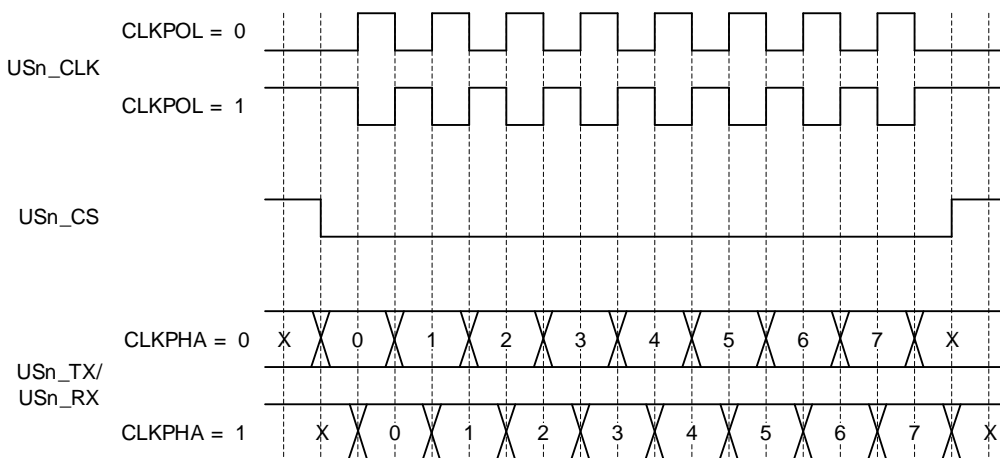

If CPHA=1, the TX underflow flag, TXUF, will be set on the first setup clock edge of a frame in slave mode if TX data is not available. If CPHA=0, TXUF is set if data is not available in the transmit buffer three HFPERCLK cycles prior to the first sample clock edge. The RXDATAV flag is updated on the last sample clock edge of a transfer, while the RX overflow interrupt flag, RXOF, is set on the first sample clock edge if the receive buffer overflows. When a transfer has been performed, interrupt flags TXBL and TXC are updated on the first setup clock edge of the succeeding frame, or when CS is deasserted.

16.3.3.3 Master Mode

When in master mode, the USART is in full control of the data flow on the synchronous bus. When operating in full duplex mode, the slave cannot transmit data to the master without the master transmitting to the slave. The master outputs the bus clock on USn_CLK.

Communication starts whenever there is data in the transmit buffer and the transmitter is enabled. The USART clock then starts, and the master shifts bits out from the transmit shift register using the internal clock.

When there are no more frames in the transmit buffer and the transmit shift register is empty, the clock stops, and communication ends. When the receiver is enabled, it samples data using the internal clock when the transmitter transmits data. Operation of the RX and TX buffers is as in asynchronous mode.

16.3.3.3.1 Operation of USn_CS Pin

When operating in master mode, the USn_CS pin can have one of two functions, or it can be disabled.

If USn_CS is configured as an output, it can be used to automatically generate a chip select for a slave by setting AUTOCS in USARTn_CTRL. If AUTOCS is set, USn_CS is activated when a transmission begins, and deactivated directly after the last bit has been transmitted and there is no more data in the transmit buffer. By default, USn_CS is active low, but its polarity can be inverted by setting CSINV in USARTn_CTRL.

When USn_CS is configured as an input, it can be used by another master that wants control of the bus to make the USART release it. When USn_CS is driven low, or high if CSINV is set, the interrupt flag SSM in USARTn_IF is set, and if CSMA in USARTn_CTRL is set, the USART goes to slave mode.

16.3.3.4 Slave Mode

When the USART is in slave mode, data transmission is not controlled by the USART, but by an external master. The USART is therefore not able to initiate a transmission, and has no control over the number of bytes written to the master.

The output and input to the USART are also swapped when in slave mode, making the receiver take its input from USn_TX (MOSI) and the transmitter drive USn_RX (MISO).

To transmit data when in slave mode, the slave must load data into the transmit buffer and enable the transmitter. The data will remain in the USART until the master starts a transmission by pulling the USn_CS input of the slave low and transmitting data. For every frame the master transmits to the slave, a frame is transferred from the slave to the master. After a transmission, MISO remains in the same state as the last bit transmitted. This also applies if the master transmits to the slave and the slave TX buffer is empty.

If the transmitter is enabled in synchronous slave mode and the master starts transmission of a frame, the underflow interrupt flag TXUF in USARTn_IF will be set if no data is available for transmission to the master.

If the slave needs to control its own chip select signal, this can be achieved by clearing CSPEN in the ROUTE register. The internal chip select signal can then be controlled through CSINV in the CTRL register. The chip select signal will be CSINV inverted, i.e. if CSINV is cleared, the chip select is active and vice versa.

16.3.3.5 Synchronous Half Duplex Communication

Half duplex communication in synchronous mode is very similar to half duplex communication in asynchronous mode as detailed in Section 16.3.2.6 (p. 187). The main difference is that in this mode, the master must generate the bus clock even when it is not transmitting data, i.e. it must provide the slave with a clock to receive data. To generate the bus clock, the master should transmit data with the transmitter tristated, i.e. TXTRI in USARTn_STATUS set, when receiving data. If 2 bytes are expected from the slave, then transmit 2 bytes with the transmitter tristated, and the slave uses the generated bus clock to transmit data to the master. TXTRI can be set by setting the TXTRIEN command bit in USARTn_CMD.

Note

When operating as SPI slave in half duplex mode, TX has to be tristated (not disabled) during data reception if the slave is to transmit data in the current transfer.

16.3.4 PRS-triggered Transmissions

If a transmission must be started on an event with very little delay, the PRS system can be used to trigger the transmission. The PRS channel to use as a trigger can be selected using TSEL in USARTn_TRIGCTRL. When a positive edge is detected on this signal, the receiver is enabled if RXTEN in USARTn_TRIGCTRL is set, and the transmitter is enabled if TXTEN in USARTn_TRIGCTRL is set. Only one signal input is supported by the USART.

16.3.5 DMA Support

The USART has full DMA support. The DMA controller can write to the transmit buffer using the registers USARTn_TXDATA, USARTn_TXDATAx, USARTn_TXDOUBLE and USARTn_TXDOUBLEX, and it can read from the receive buffer using the registers USARTn_RXDATA, USARTn_RXDATAx, USARTn_RXDOUBLE and USARTn_RXDOUBLEX. This enables single byte transfers, 9 bit data + control/status bits, double byte and double byte + control/status transfers both to and from the USART.

A request for the DMA controller to read from the USART receive buffer can come from the following source:

- Data available in the receive buffer

A write request can come from one of the following sources:

- Transmit buffer and shift register empty. No data to send.
- Transmit buffer has room for more data

Even though there are two sources for write requests to the DMA, only one should be used at a time, since the requests from both sources are cleared even though only one of the requests are used.

In some cases, it may be sensible to temporarily stop DMA access to the USART when an error such as a framing error has occurred. This is enabled by setting ERRSDMA in USARTn_CTRL.

16.3.6 Transmission Delay

By configuring TXDELAY in USARTn_CTRL, the transmitter can be forced to wait a number of bit-periods from it is ready to transmit data, to it actually transmits the data. This delay is only applied to the first frame transmitted after the transmitter has been idle. When transmitting frames back-to-back the delay is not introduced between the transmitted frames.

This is useful on half duplex buses, because the receiver always returns received frames to software during the first stop-bit. The bus may still be driven for up to 3 baud periods, depending on the current frame format. Using the transmission delay, a transmission can be started when a frame is received, and it is possible to make sure that the transmitter does not begin driving the output before the frame on the bus is completely transmitted.

TXDELAY in USARTn_CTRL only applies to asynchronous transmission.

16.3.7 Interrupts

The interrupts generated by the USART are combined into two interrupt vectors. Interrupts related to reception are assigned to one interrupt vector, and interrupts related to transmission are assigned to the other. Separating the interrupts in this way allows different priorities to be set for transmission and reception interrupts.

The transmission interrupt vector groups the transmission-related interrupts generated by the following interrupt flags:

- TXC
- TXBL

- TXOF
- CCF

The reception interrupt on the other hand groups the reception-related interrupts, triggered by the following interrupt flags:

- RXDATAV
- RXFULL
- RXOF
- RXUF
- PERR
- FERR
- MPAF
- SSM

If USART interrupts are enabled, an interrupt will be made if one or more of the interrupt flags in USART_IF and their corresponding bits in USART_IEN are set.

16.3.8 IrDA Modulator/ Demodulator

The IrDA modulator on USART0 implements the physical layer of the IrDA specification, which is necessary for communication over IrDA. The modulator takes the signal output from the USART module, and modulates it before it leaves USART0. In the same way, the input signal is demodulated before it enters the actual USART module. The modulator is only available on USART0, and supports speeds from 2.4 kbps to 1.152 Mbps.

The data from and to the USART is represented in a NRZ (Non Return to Zero) format, where the signal value is at the same level through the entire bit period. For IrDA, the required format is RZI (Return to Zero Inverted), a format where a “1” is signalled by holding the line low, and a “0” is signalled by a short high pulse. An example is given in Figure 16.16 (p. 197) .

Figure 16.16. USART Example RZI Signal for a given Asynchronous USART Frame

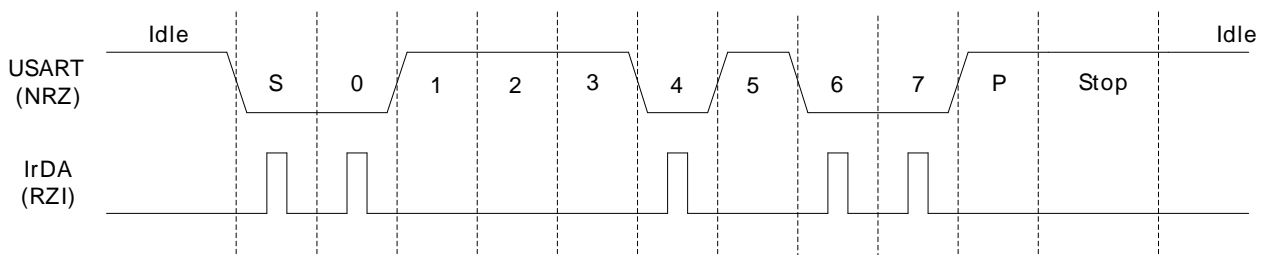

The IrDA module is enabled by setting IREN. The USART transmitter output and receiver input is then routed through the IrDA modulator.

The width of the pulses generated by the IrDA modulator is set by configuring IRPW in USARTn_IRCTRL. Four pulse widths are available, each defined relative to the configured bit period as listed in Table 16.9 (p. 197) .

Table 16.9. USART IrDA Pulse Widths

IRPW	Pulse width OVS=0	Pulse width OVS=1	Pulse width OVS=2	Pulse width OVS=3
00	1/16	1/8	1/6	1/4
01	2/16	2/8	2/6	N/A
10	3/16	3/8	N/A	N/A
11	4/16	N/A	N/A	N/A

By default, no filter is enabled in the IrDA demodulator. A filter can be enabled by setting IRFILT in USARTn_IRCTRL. When the filter is enabled, an incoming pulse has to last for 4 consecutive clock cycles to be detected by the IrDA demodulator.

Note that by default, the idle value of the USART data signal is high. This means that the IrDA modulator generates negative pulses, and the IrDA demodulator expects negative pulses. To make the IrDA module use RZI signalling, both TXINV and RXINV in USARTn_CTRL must be set.

The IrDA module can also modulate a signal from the PRS system, and transmit a modulated signal to the PRS system. To use a PRS channel as transmitter source instead of the USART, set IRPRSEN in USARTn_IRCTRL high. The channel is selected by configuring IRPRSSEL in USARTn_IRCTRL.

16.4 Register Map

The offset register address is relative to the registers base address.

Offset	Name	Type	Description
0x000	USARTn_CTRL	RW	Control Register
0x004	USARTn_FRAME	RW	USART Frame Format Register
0x008	USARTn_TRIGCTRL	RW	USART Trigger Control register
0x00C	USARTn_CMD	W1	Command Register
0x010	USARTn_STATUS	R	USART Status Register
0x014	USARTn_CLKDIV	RW	Clock Control Register
0x018	USARTn_RXDATAx	R	RX Buffer Data Extended Register
0x01C	USARTn_RXDATA	R	RX Buffer Data Register
0x020	USARTn_RXDOUBLEX	R	RX Buffer Double Data Extended Register
0x024	USARTn_RXDOUBLE	R	RX FIFO Double Data Register
0x028	USARTn_RXDATAxP	R	RX Buffer Data Extended Peek Register
0x02C	USARTn_RXDOUBLEXP	R	RX Buffer Double Data Extended Peek Register
0x030	USARTn_TXDATAx	W	TX Buffer Data Extended Register
0x034	USARTn_TXDATA	W	TX Buffer Data Register
0x038	USARTn_TXDOUBLEX	W	TX Buffer Double Data Extended Register
0x03C	USARTn_TXDOUBLE	W	TX Buffer Double Data Register
0x040	USARTn_IF	R	Interrupt Flag Register
0x044	USARTn_IFS	W1	Interrupt Flag Set Register
0x048	USARTn_IFC	W1	Interrupt Flag Clear Register
0x04C	USARTn_IEN	RW	Interrupt Enable Register
0x050	USARTn_IRCTRL	RW	IrDA Control Register
0x054	USARTn_ROUTE	RW	I/O Routing Register

16.5 Register Description

16.5.1 USARTn_CTRL - Control Register

Offset	Bit Position																															
0x000	31	30	29	28	27	26	25	24	23	22	21	20	19	18	17	16	15	14	13	12	11	10	9	8	7	6	5	4	3	2	1	0
Reset				0	0x0			0	0	0	0	0	0	0	0	0	0	0	0	0	0	0	0	0			0x0	0	0	0	0	0
Access				RW	RW			RW	RW	RW	RW	RW	RW	RW	RW	RW	RW	RW	RW	RW	RW	RW	RW	RW			RW	RW	RW	RW	RW	RW
Name				BYTESWAP	TXDELAY			ERRSTX	ERRSRX	ERRSDMA	BIT8DV	SKIPERRF	SCRETRANS	SCMODE	AUTOTRI	AUTOCS	CSINV	TXINV	RXINV	TXBIL	CSMA	MSBF	CLKPHA	CLKPOL			OVS	MPAB	MPM	CCEN	LOOPBK	SYNC

Bit	Name	Reset	Access	Description
31:29	Reserved			To ensure compatibility with future devices, always write bits to 0. More information in Section 2.1 (p. 3)

28	BYTESWAP	0	RW	Byteswap In Double Accesses Set to switch the order of the bytes in double accesses.						
<table border="1"> <thead> <tr> <th>Value</th> <th>Description</th> </tr> </thead> <tbody> <tr> <td>0</td> <td>Normal byte order</td> </tr> <tr> <td>1</td> <td>Byte order swapped</td> </tr> </tbody> </table>					Value	Description	0	Normal byte order	1	Byte order swapped
Value	Description									
0	Normal byte order									
1	Byte order swapped									

Bit	Name	Reset	Access	Description															
27:26	TXDELAY	0x0	RW	TX Delay Transmission Configurable delay before new transfers. Frames sent back-to-back are not delayed. <table border="1"> <thead> <tr> <th>Value</th> <th>Mode</th> <th>Description</th> </tr> </thead> <tbody> <tr> <td>0</td> <td>NONE</td> <td>Frames are transmitted immediately</td> </tr> <tr> <td>1</td> <td>SINGLE</td> <td>Transmission of new frames are delayed by a single baud period</td> </tr> <tr> <td>2</td> <td>DOUBLE</td> <td>Transmission of new frames are delayed by two baud periods</td> </tr> <tr> <td>3</td> <td>TRIPLE</td> <td>Transmission of new frames are delayed by three baud periods</td> </tr> </tbody> </table>	Value	Mode	Description	0	NONE	Frames are transmitted immediately	1	SINGLE	Transmission of new frames are delayed by a single baud period	2	DOUBLE	Transmission of new frames are delayed by two baud periods	3	TRIPLE	Transmission of new frames are delayed by three baud periods
Value	Mode	Description																	
0	NONE	Frames are transmitted immediately																	
1	SINGLE	Transmission of new frames are delayed by a single baud period																	
2	DOUBLE	Transmission of new frames are delayed by two baud periods																	
3	TRIPLE	Transmission of new frames are delayed by three baud periods																	
25	<i>Reserved</i>	<i>To ensure compatibility with future devices, always write bits to 0. More information in Section 2.1 (p. 3)</i>																	
24	ERRSTX	0	RW	Disable TX On Error When set, the transmitter is disabled on framing and parity errors (asynchronous mode only) in the receiver. <table border="1"> <thead> <tr> <th>Value</th> <th>Description</th> </tr> </thead> <tbody> <tr> <td>0</td> <td>Received framing and parity errors have no effect on transmitter</td> </tr> <tr> <td>1</td> <td>Received framing and parity errors disable the transmitter</td> </tr> </tbody> </table>	Value	Description	0	Received framing and parity errors have no effect on transmitter	1	Received framing and parity errors disable the transmitter									
Value	Description																		
0	Received framing and parity errors have no effect on transmitter																		
1	Received framing and parity errors disable the transmitter																		
23	ERRSRX	0	RW	Disable RX On Error When set, the receiver is disabled on framing and parity errors (asynchronous mode only). <table border="1"> <thead> <tr> <th>Value</th> <th>Description</th> </tr> </thead> <tbody> <tr> <td>0</td> <td>Framing and parity errors have no effect on receiver</td> </tr> <tr> <td>1</td> <td>Framing and parity errors disable the receiver</td> </tr> </tbody> </table>	Value	Description	0	Framing and parity errors have no effect on receiver	1	Framing and parity errors disable the receiver									
Value	Description																		
0	Framing and parity errors have no effect on receiver																		
1	Framing and parity errors disable the receiver																		
22	ERRSDMA	0	RW	Halt DMA On Error When set, DMA requests will be cleared on framing and parity errors (asynchronous mode only). <table border="1"> <thead> <tr> <th>Value</th> <th>Description</th> </tr> </thead> <tbody> <tr> <td>0</td> <td>Framing and parity errors have no effect on DMA requests from the USART</td> </tr> <tr> <td>1</td> <td>DMA requests from the USART are blocked while the PERR or FERR interrupt flags are set</td> </tr> </tbody> </table>	Value	Description	0	Framing and parity errors have no effect on DMA requests from the USART	1	DMA requests from the USART are blocked while the PERR or FERR interrupt flags are set									
Value	Description																		
0	Framing and parity errors have no effect on DMA requests from the USART																		
1	DMA requests from the USART are blocked while the PERR or FERR interrupt flags are set																		
21	BIT8DV	0	RW	Bit 8 Default Value The default value of the 9th bit. If 9-bit frames are used, and an 8-bit write operation is done, leaving the 9th bit unspecified, the 9th bit is set to the value of BIT8DV.															
20	SKIPPERRF	0	RW	Skip Parity Error Frames When set, the receiver discards frames with parity errors (asynchronous mode only). The PERR interrupt flag is still set.															
19	SCRETRANS	0	RW	SmartCard Retransmit When in SmartCard mode, a NACK'ed frame will be kept in the shift register and retransmitted if the transmitter is still enabled.															
18	SCMODE	0	RW	SmartCard Mode Use this bit to enable or disable SmartCard mode.															
17	AUTOTRI	0	RW	Automatic TX Tristate When enabled, TXTRI is set by hardware whenever the transmitter is idle, and TXTRI is cleared by hardware when transmission starts. <table border="1"> <thead> <tr> <th>Value</th> <th>Description</th> </tr> </thead> <tbody> <tr> <td>0</td> <td>The output on U(S)n_TX when the transmitter is idle is defined by TXINV</td> </tr> <tr> <td>1</td> <td>U(S)n_TX is tristated whenever the transmitter is idle</td> </tr> </tbody> </table>	Value	Description	0	The output on U(S)n_TX when the transmitter is idle is defined by TXINV	1	U(S)n_TX is tristated whenever the transmitter is idle									
Value	Description																		
0	The output on U(S)n_TX when the transmitter is idle is defined by TXINV																		
1	U(S)n_TX is tristated whenever the transmitter is idle																		
16	AUTOCS	0	RW	Automatic Chip Select When enabled, the output on USn_CS will be activated one baud-period before transmission starts, and deactivated when transmission ends.															
15	CSINV	0	RW	Chip Select Invert Default value is active low. This affects both the selection of external slaves, as well as the selection of the microcontroller as a slave. <table border="1"> <thead> <tr> <th>Value</th> <th>Description</th> </tr> </thead> <tbody> <tr> <td>0</td> <td>Chip select is active low</td> </tr> <tr> <td>1</td> <td>Chip select is active high</td> </tr> </tbody> </table>	Value	Description	0	Chip select is active low	1	Chip select is active high									
Value	Description																		
0	Chip select is active low																		
1	Chip select is active high																		
14	TXINV	0	RW	Transmitter output Invert The output from the USART transmitter can optionally be inverted by setting this bit.															

Bit	Name	Reset	Access	Description
	Value	Description		
	0	Output from the transmitter is passed unchanged to U(S)n_TX		
	1	Output from the transmitter is inverted before it is passed to U(S)n_TX		
13	RXINV	0	RW	Receiver Input Invert Setting this bit will invert the input to the USART receiver.
	Value	Description		
	0	Input is passed directly to the receiver		
	1	Input is inverted before it is passed to the receiver		
12	TXBIL	0	RW	TX Buffer Interrupt Level Determines the interrupt and status level of the transmit buffer.
	Value	Mode	Description	
	0	EMPTY	TXBL and the TXBL interrupt flag are set when the transmit buffer becomes empty. TXBL is cleared when the buffer becomes nonempty.	
	1	HALFFULL	TXBL and TXBLIF are set when the transmit buffer goes from full to half-full or empty. TXBL is cleared when the buffer becomes full.	
11	CSMA	0	RW	Action On Slave-Select In Master Mode This register determines the action to be performed when slave-select is configured as an input and driven low while in master mode.
	Value	Mode	Description	
	0	NOACTION	No action taken	
	1	GOTOSLAVEMODE	Go to slave mode	
10	MSBF	0	RW	Most Significant Bit First Decides whether data is sent with the least significant bit first, or the most significant bit first.
	Value	Description		
	0	Data is sent with the least significant bit first		
	1	Data is sent with the most significant bit first		
9	CLKPHA	0	RW	Clock Edge For Setup/Sample Determines where data is set-up and sampled according to the bus clock when in synchronous mode.
	Value	Mode	Description	
	0	SAMPLELEADING	Data is sampled on the leading edge and set-up on the trailing edge of the bus clock in synchronous mode	
	1	SAMPLETRAILING	Data is set-up on the leading edge and sampled on the trailing edge of the bus clock in synchronous mode	
8	CLKPOL	0	RW	Clock Polarity Determines the clock polarity of the bus clock used in synchronous mode.
	Value	Mode	Description	
	0	IDLELOW	The bus clock used in synchronous mode has a low base value	
	1	IDLEHIGH	The bus clock used in synchronous mode has a high base value	
7	<i>Reserved</i>		<i>To ensure compatibility with future devices, always write bits to 0. More information in Section 2.1 (p. 3)</i>	
6:5	OVS	0x0	RW	Oversampling Sets the number of clock periods in a UART bit-period. More clock cycles gives better robustness, while less clock cycles gives better performance.
	Value	Mode	Description	
	0	X16	Regular UART mode with 16X oversampling in asynchronous mode	
	1	X8	Double speed with 8X oversampling in asynchronous mode	
	2	X6	6X oversampling in asynchronous mode	
	3	X4	Quadruple speed with 4X oversampling in asynchronous mode	
4	MPAB	0	RW	Multi-Processor Address-Bit Defines the value of the multi-processor address bit. An incoming frame with its 9th bit equal to the value of this bit marks the frame as a multi-processor address frame.
3	MPM	0	RW	Multi-Processor Mode

Bit	Name	Reset	Access	Description
Multi-processor mode uses the 9th bit of the USART frames to tell whether the frame is an address frame or a data frame.				
	Value	Description		
	0	The 9th bit of incoming frames has no special function		
	1	An incoming frame with the 9th bit equal to MPAB will be loaded into the receive buffer regardless of RXBLOCK and will result in the MPAB interrupt flag being set		
2	CCEN	0	RW	Collision Check Enable
Enables collision checking on data when operating in half duplex modus.				
	Value	Description		
	0	Collision check is disabled		
	1	Collision check is enabled. The receiver must be enabled for the check to be performed		
1	LOOPBK	0	RW	Loopback Enable
Allows the receiver to be connected directly to the USART transmitter for loopback and half duplex communication.				
	Value	Description		
	0	The receiver is connected to and receives data from U(S)n_RX		
	1	The receiver is connected to and receives data from U(S)n_TX		
0	SYNC	0	RW	USART Synchronous Mode
Determines whether the USART is operating in asynchronous or synchronous mode.				
	Value	Description		
	0	The USART operates in asynchronous mode		
	1	The USART operates in synchronous mode		

16.5.2 USARTn_FRAME - USART Frame Format Register

Offset	Bit Position																																
0x004	31	30	29	28	27	26	25	24	23	22	21	20	19	18	17	16	15	14	13	12	11	10	9	8	7	6	5	4	3	2	1	0	
Reset														0x1											0x0								0x5
Access														RW											RW								RW
Name														STOPBITS											PARITY								DATABITS

Bit	Name	Reset	Access	Description
31:14	Reserved	<i>To ensure compatibility with future devices, always write bits to 0. More information in Section 2.1 (p. 3)</i>		
13:12	STOPBITS	0x1	RW	Stop-Bit Mode
Determines the number of stop-bits used.				
	Value	Mode	Description	
	0	HALF	The transmitter generates a half stop bit. Stop-bits are not verified by receiver	
	1	ONE	One stop bit is generated and verified	
	2	ONEANDAHALF	The transmitter generates one and a half stop bit. The receiver verifies the first stop bit	
	3	TWO	The transmitter generates two stop bits. The receiver checks the first stop-bit only	
11:10	Reserved	<i>To ensure compatibility with future devices, always write bits to 0. More information in Section 2.1 (p. 3)</i>		
9:8	PARITY	0x0	RW	Parity-Bit Mode
Determines whether parity bits are enabled, and whether even or odd parity should be used. Only available in asynchronous mode.				
	Value	Mode	Description	
	0	NONE	Parity bits are not used	
	2	EVEN	Even parity are used. Parity bits are automatically generated and checked by hardware.	
	3	ODD	Odd parity is used. Parity bits are automatically generated and checked by hardware.	

Bit	Name	Reset	Access	Description
7:4	Reserved	To ensure compatibility with future devices, always write bits to 0. More information in Section 2.1 (p. 3)		

3:0 DATABITS 0x5 RW **Data-Bit Mode**

This register sets the number of data bits in a USART frame.

Value	Mode	Description
1	FOUR	Each frame contains 4 data bits
2	FIVE	Each frame contains 5 data bits
3	SIX	Each frame contains 6 data bits
4	SEVEN	Each frame contains 7 data bits
5	EIGHT	Each frame contains 8 data bits
6	NINE	Each frame contains 9 data bits
7	TEN	Each frame contains 10 data bits
8	ELEVEN	Each frame contains 11 data bits
9	TWELVE	Each frame contains 12 data bits
10	THIRTEEN	Each frame contains 13 data bits
11	FOURTEEN	Each frame contains 14 data bits
12	FIFTEEN	Each frame contains 15 data bits
13	SIXTEEN	Each frame contains 16 data bits

16.5.3 USARTn_TRIGCTRL - USART Trigger Control register

Offset	Bit Position																																																												
	31	30	29	28	27	26	25	24	23	22	21	20	19	18	17	16	15	14	13	12	11	10	9	8	7	6	5	4	3	2	1	0																													
0x008																																																													
Reset																																																												0x0	
Access																																																													
Name																																																													

Bit	Name	Reset	Access	Description
31:6	Reserved	To ensure compatibility with future devices, always write bits to 0. More information in Section 2.1 (p. 3)		

5 TXTEN 0 RW **Transmit Trigger Enable**

When set, the PRS channel selected by TSEL sets TXEN, enabling the transmitter on positive trigger edges.

4 RXTEN 0 RW **Receive Trigger Enable**

When set, the PRS channel selected by TSEL sets RXEN, enabling the receiver on positive trigger edges.

3	Reserved	To ensure compatibility with future devices, always write bits to 0. More information in Section 2.1 (p. 3)		
---	----------	---	--	--

2:0 TSEL 0x0 RW **Trigger PRS Channel Select**

Select USART PRS trigger channel. The PRS signal can enable RX and/or TX, depending on the setting of RXTEN and TXTEN.

Value	Mode	Description
0	PRSCH0	PRS Channel 0 selected
1	PRSCH1	PRS Channel 1 selected
2	PRSCH2	PRS Channel 2 selected
3	PRSCH3	PRS Channel 3 selected
4	PRSCH4	PRS Channel 4 selected
5	PRSCH5	PRS Channel 5 selected
6	PRSCH6	PRS Channel 6 selected
7	PRSCH7	PRS Channel 7 selected

16.5.4 USARTn_CMD - Command Register

Offset	Bit Position																																
	31	30	29	28	27	26	25	24	23	22	21	20	19	18	17	16	15	14	13	12	11	10	9	8	7	6	5	4	3	2	1	0	
0x00C																																	
Reset																						0	0	0	0	0	0	0	0	0	0	0	0
Access																						W1	W1	W1	W1	W1	W1	W1	W1	W1	W1	W1	W1
Name																						CLEARRX	CLEARTX	TXTRIDIS	TXTRIEN	RXBLOCKDIS	RXBLOCKEN	MASTERDIS	MASTEREN	TXDIS	TXEN	RXDIS	RXEN

Bit	Name	Reset	Access	Description
31:12	Reserved	<i>To ensure compatibility with future devices, always write bits to 0. More information in Section 2.1 (p. 3)</i>		
11	CLEARRX	0	W1	Clear RX Set to clear receive buffer and the RX shift register.
10	CLEARTX	0	W1	Clear TX Set to clear transmit buffer and the TX shift register.
9	TXTRIDIS	0	W1	Transmitter Tristate Disable Disables tristating of the transmitter output.
8	TXTRIEN	0	W1	Transmitter Tristate Enable Tristates the transmitter output.
7	RXBLOCKDIS	0	W1	Receiver Block Disable Set to clear RXBLOCK, resulting in all incoming frames being loaded into the receive buffer.
6	RXBLOCKEN	0	W1	Receiver Block Enable Set to set RXBLOCK, resulting in all incoming frames being discarded.
5	MASTERDIS	0	W1	Master Disable Set to disable master mode, clearing the MASTER status bit and putting the USART in slave mode.
4	MASTEREN	0	W1	Master Enable Set to enable master mode, setting the MASTER status bit. Master mode should not be enabled while TXENS is set to 1. To enable both master and TX mode, write MASTEREN before TXEN, or enable them both in the same write operation.
3	TXDIS	0	W1	Transmitter Disable Set to disable transmission.
2	TXEN	0	W1	Transmitter Enable Set to enable data transmission.
1	RXDIS	0	W1	Receiver Disable Set to disable data reception. If a frame is under reception when the receiver is disabled, the incoming frame is discarded.
0	RXEN	0	W1	Receiver Enable Set to activate data reception on U(S)n_RX.

16.5.5 USARTn_STATUS - USART Status Register

Offset	Bit Position																																																					
0x010	31	30	29	28	27	26	25	24	23	22	21	20	19	18	17	16	15	14	13	12	11	10	9	8	7	6	5	4	3	2	1	0																						
Reset																								0	0	1	0	0	0	0	0	0	0	0	0	0	0	0	0	0	0	0	0	0	0	0	0	0	0	0	0	0	0	
Access																								R	R	R	R	R	R	R	R	R	R	R	R	R	R	R	R	R	R	R	R	R	R	R	R	R	R	R	R	R	R	R
Name																								RXFULL	RXDATAV	TXBL	TXC	TXTRI	RXBLOCK	MASTER	TXENS	RXENS																						

Bit	Name	Reset	Access	Description
31:9	Reserved	To ensure compatibility with future devices, always write bits to 0. More information in Section 2.1 (p. 3)		
8	RXFULL	0	R	RX FIFO Full Set when the RXFIFO is full. Cleared when the receive buffer is no longer full. When this bit is set, there is still room for one more frame in the receive shift register.
7	RXDATAV	0	R	RX Data Valid Set when data is available in the receive buffer. Cleared when the receive buffer is empty.
6	TXBL	1	R	TX Buffer Level Indicates the level of the transmit buffer. If TXBIL is cleared, TXBL is set whenever the transmit buffer is empty, and if TXBIL is set, TXBL is set whenever the transmit buffer is half-full or empty.
5	TXC	0	R	TX Complete Set when a transmission has completed and no more data is available in the transmit buffer. Cleared when data is written to the transmit buffer.
4	TXTRI	0	R	Transmitter Tristated Set when the transmitter is tristated, and cleared when transmitter output is enabled. If AUTOTRI in USARTn_CTRL is set this bit is always read as 0.
3	RXBLOCK	0	R	Block Incoming Data When set, the receiver discards incoming frames. An incoming frame will not be loaded into the receive buffer if this bit is set at the instant the frame has been completely received.
2	MASTER	0	R	SPI Master Mode Set when the USART operates as a master. Set using the MASTEREN command and clear using the MASTERDIS command.
1	TXENS	0	R	Transmitter Enable Status Set when the transmitter is enabled.
0	RXENS	0	R	Receiver Enable Status Set when the receiver is enabled.

16.5.6 USARTn_CLKDIV - Clock Control Register

Offset	Bit Position																															
0x014	31	30	29	28	27	26	25	24	23	22	21	20	19	18	17	16	15	14	13	12	11	10	9	8	7	6	5	4	3	2	1	0
Reset													0x0000																			
Access													RW																			
Name													DIV																			

Bit	Name	Reset	Access	Description
31:21	Reserved	To ensure compatibility with future devices, always write bits to 0. More information in Section 2.1 (p. 3)		
20:6	DIV	0x0000	RW	Fractional Clock Divider Specifies the fractional clock divider for the USART.
5:0	Reserved	To ensure compatibility with future devices, always write bits to 0. More information in Section 2.1 (p. 3)		

16.5.7 USARTn_RXDATAx - RX Buffer Data Extended Register

Offset	Bit Position																																			
	31	30	29	28	27	26	25	24	23	22	21	20	19	18	17	16	15	14	13	12	11	10	9	8	7	6	5	4	3	2	1	0				
0x018																	0	0																	0x000	
Reset																	0	0																	0x000	
Access																	R	R																	R	
Name																	FERR	PERR																	RXDATA	

Bit	Name	Reset	Access	Description
31:16	Reserved	To ensure compatibility with future devices, always write bits to 0. More information in Section 2.1 (p. 3)		
15	FERR	0	R	Data Framing Error Set if data in buffer has a framing error. Can be the result of a break condition.
14	PERR	0	R	Data Parity Error Set if data in buffer has a parity error (asynchronous mode only).
13:9	Reserved	To ensure compatibility with future devices, always write bits to 0. More information in Section 2.1 (p. 3)		
8:0	RXDATA	0x000	R	RX Data Use this register to access data read from the USART. Buffer is cleared on read access.

16.5.8 USARTn_RXDATA - RX Buffer Data Register

Offset	Bit Position																																	
	31	30	29	28	27	26	25	24	23	22	21	20	19	18	17	16	15	14	13	12	11	10	9	8	7	6	5	4	3	2	1	0		
0x01C																																	0x00	
Reset																																	0x00	
Access																																	R	
Name																																	RXDATA	

Bit	Name	Reset	Access	Description
31:8	Reserved	To ensure compatibility with future devices, always write bits to 0. More information in Section 2.1 (p. 3)		
7:0	RXDATA	0x00	R	RX Data Use this register to access data read from USART. Buffer is cleared on read access. Only the 8 LSB can be read using this register.

16.5.9 USARTn_RXDOUBLEX - RX Buffer Double Data Extended Register

Offset	Bit Position																															
0x020	31	30	29	28	27	26	25	24	23	22	21	20	19	18	17	16	15	14	13	12	11	10	9	8	7	6	5	4	3	2	1	0
Reset	0	0										0x000					0	0														0x000
Access	R	R										R					R	R														R
Name	FERR1	PERR1										RXDATA1					FERR0	PERR0														RXDATA0

Bit	Name	Reset	Access	Description
31	FERR1	0	R	Data Framing Error 1 Set if data in buffer has a framing error. Can be the result of a break condition.
30	PERR1	0	R	Data Parity Error 1 Set if data in buffer has a parity error (asynchronous mode only).
29:25	<i>Reserved</i>	<i>To ensure compatibility with future devices, always write bits to 0. More information in Section 2.1 (p. 3)</i>		
24:16	RXDATA1	0x000	R	RX Data 1 Second frame read from buffer.
15	FERR0	0	R	Data Framing Error 0 Set if data in buffer has a framing error. Can be the result of a break condition.
14	PERR0	0	R	Data Parity Error 0 Set if data in buffer has a parity error (asynchronous mode only).
13:9	<i>Reserved</i>	<i>To ensure compatibility with future devices, always write bits to 0. More information in Section 2.1 (p. 3)</i>		
8:0	RXDATA0	0x000	R	RX Data 0 First frame read from buffer.

16.5.10 USARTn_RXDOUBLE - RX FIFO Double Data Register

Offset	Bit Position																																
0x024	31	30	29	28	27	26	25	24	23	22	21	20	19	18	17	16	15	14	13	12	11	10	9	8	7	6	5	4	3	2	1	0	
Reset																																	0x00
Access																																	R
Name																																	RXDATA1

Bit	Name	Reset	Access	Description
31:16	<i>Reserved</i>	<i>To ensure compatibility with future devices, always write bits to 0. More information in Section 2.1 (p. 3)</i>		
15:8	RXDATA1	0x00	R	RX Data 1 Second frame read from buffer.
7:0	RXDATA0	0x00	R	RX Data 0 First frame read from buffer.

16.5.11 USARTn_RXDATAXP - RX Buffer Data Extended Peek Register

Offset	Bit Position																																		
0x028	31	30	29	28	27	26	25	24	23	22	21	20	19	18	17	16	15	14	13	12	11	10	9	8	7	6	5	4	3	2	1	0			
Reset																	0	0																	0x000
Access																	R	R																	R
Name																	FERRP	PERRP																	RXDATAP

Bit	Name	Reset	Access	Description
31:16	Reserved	To ensure compatibility with future devices, always write bits to 0. More information in Section 2.1 (p. 3)		
15	FERRP	0	R	Data Framing Error Peek Set if data in buffer has a framing error. Can be the result of a break condition.
14	PERRP	0	R	Data Parity Error Peek Set if data in buffer has a parity error (asynchronous mode only).
13:9	Reserved	To ensure compatibility with future devices, always write bits to 0. More information in Section 2.1 (p. 3)		
8:0	RXDATAP	0x000	R	RX Data Peek Use this register to access data read from the USART.

16.5.12 USARTn_RXDOUBLEXP - RX Buffer Double Data Extended Peek Register

Offset	Bit Position																																					
0x02C	31	30	29	28	27	26	25	24	23	22	21	20	19	18	17	16	15	14	13	12	11	10	9	8	7	6	5	4	3	2	1	0						
Reset	0	0																	0x000	0	0																	0x000
Access	R	R																	R	R	R																	R
Name	FERRP1	PERRP1																	RXDATAP1	FERRP0	PERRP0																	RXDATAP0

Bit	Name	Reset	Access	Description
31	FERRP1	0	R	Data Framing Error 1 Peek Set if data in buffer has a framing error. Can be the result of a break condition.
30	PERRP1	0	R	Data Parity Error 1 Peek Set if data in buffer has a parity error (asynchronous mode only).
29:25	Reserved	To ensure compatibility with future devices, always write bits to 0. More information in Section 2.1 (p. 3)		
24:16	RXDATAP1	0x000	R	RX Data 1 Peek Second frame read from FIFO.
15	FERRP0	0	R	Data Framing Error 0 Peek Set if data in buffer has a framing error. Can be the result of a break condition.
14	PERRP0	0	R	Data Parity Error 0 Peek

Bit	Name	Reset	Access	Description
Set if data in buffer has a parity error (asynchronous mode only).				
13:9	<i>Reserved</i>	<i>To ensure compatibility with future devices, always write bits to 0. More information in Section 2.1 (p. 3)</i>		
8:0	RXDATAPO	0x000	R	RX Data 0 Peek First frame read from FIFO.

16.5.13 USARTn_TXDATAx - TX Buffer Data Extended Register

Offset	Bit Position																																					
	31	30	29	28	27	26	25	24	23	22	21	20	19	18	17	16	15	14	13	12	11	10	9	8	7	6	5	4	3	2	1	0						
0x030																	0	0	0	0	0																	
Reset																	0	0	0	0	0																	
Access																	W	W	W	W	W																	
Name																	RXENAT	TXDISAT	TXBREAK	TXTRIAT	UBRXAT																	
																						TXDATAx																

Bit	Name	Reset	Access	Description
31:16	<i>Reserved</i>	<i>To ensure compatibility with future devices, always write bits to 0. More information in Section 2.1 (p. 3)</i>		
15	RXENAT	0	W	Enable RX After Transmission Set to enable reception after transmission.
14	TXDISAT	0	W	Clear TXEN After Transmission Set to disable transmitter and release data bus directly after transmission.
13	TXBREAK	0	W	Transmit Data As Break Set to send data as a break. Recipient will see a framing error or a break condition depending on its configuration and the value of WDATA.
12	TXTRIAT	0	W	Set TXTRI After Transmission Set to tristate transmitter by setting TXTRI after transmission.
11	UBRXAT	0	W	Unblock RX After Transmission Set clear RXBLOCK after transmission, unblocking the receiver.
10:9	<i>Reserved</i>	<i>To ensure compatibility with future devices, always write bits to 0. More information in Section 2.1 (p. 3)</i>		
8:0	TXDATAx	0x000	W	TX Data Use this register to write data to the USART. If TXEN is set, a transfer will be initiated at the first opportunity.

16.5.14 USARTn_TXDATA - TX Buffer Data Register

Offset	Bit Position																															
	31	30	29	28	27	26	25	24	23	22	21	20	19	18	17	16	15	14	13	12	11	10	9	8	7	6	5	4	3	2	1	0
0x034																																
Reset																																
Access																																
Name																																

Bit	Name	Reset	Access	Description
31:8	Reserved	To ensure compatibility with future devices, always write bits to 0. More information in Section 2.1 (p. 3)		
7:0	TXDATA	0x00	W	TX Data
This frame will be added to TX buffer. Only 8 LSB can be written using this register. 9th bit and control bits will be cleared.				

16.5.15 USARTn_TXDOUBLEX - TX Buffer Double Data Extended Register

Offset	Bit Position																																
	31	30	29	28	27	26	25	24	23	22	21	20	19	18	17	16	15	14	13	12	11	10	9	8	7	6	5	4	3	2	1	0	
0x038	0	0	0	0	0							0x000						0	0	0	0	0											0x000
Access	W	W	W	W	W							W						W	W	W	W	W										W	
Name	RXENAT1	TXDISAT1	TXBREAK1	TXTRIAT1	UBRXAT1							TXDATA1						RXENAT0	TXDISAT0	TXBREAK0	TXTRIAT0	UBRXAT0										TXDATA0	

Bit	Name	Reset	Access	Description
31	RXENAT1	0	W	Enable RX After Transmission Set to enable reception after transmission.
30	TXDISAT1	0	W	Clear TXEN After Transmission Set to disable transmitter and release data bus directly after transmission.
29	TXBREAK1	0	W	Transmit Data As Break Set to send data as a break. Recipient will see a framing error or a break condition depending on its configuration and the value of USARTn_WDATA.
28	TXTRIAT1	0	W	Set TXTRI After Transmission Set to tristate transmitter by setting TXTRI after transmission.
27	UBRXAT1	0	W	Unblock RX After Transmission Set clear RXBLOCK after transmission, unblocking the receiver.
26:25	Reserved	To ensure compatibility with future devices, always write bits to 0. More information in Section 2.1 (p. 3)		
24:16	TXDATA1	0x000	W	TX Data Second frame to write to FIFO.
15	RXENAT0	0	W	Enable RX After Transmission Set to enable reception after transmission.
14	TXDISAT0	0	W	Clear TXEN After Transmission Set to disable transmitter and release data bus directly after transmission.
13	TXBREAK0	0	W	Transmit Data As Break Set to send data as a break. Recipient will see a framing error or a break condition depending on its configuration and the value of WDATA.
12	TXTRIAT0	0	W	Set TXTRI After Transmission Set to tristate transmitter by setting TXTRI after transmission.
11	UBRXAT0	0	W	Unblock RX After Transmission Set clear RXBLOCK after transmission, unblocking the receiver.
10:9	Reserved	To ensure compatibility with future devices, always write bits to 0. More information in Section 2.1 (p. 3)		
8:0	TXDATA0	0x000	W	TX Data First frame to write to buffer.

16.5.16 USARTn_TXDOUBLE - TX Buffer Double Data Register

Offset	Bit Position																															
0x03C	31	30	29	28	27	26	25	24	23	22	21	20	19	18	17	16	15	14	13	12	11	10	9	8	7	6	5	4	3	2	1	0
Reset																	0x00								0x00							
Access																	W								W							
Name																	TXDATA1								TXDATA0							

Bit	Name	Reset	Access	Description
31:16	Reserved	To ensure compatibility with future devices, always write bits to 0. More information in Section 2.1 (p. 3)		
15:8	TXDATA1	0x00	W	TX Data Second frame to write to buffer.
7:0	TXDATA0	0x00	W	TX Data First frame to write to buffer.

16.5.17 USARTn_IF - Interrupt Flag Register

Offset	Bit Position																																																	
0x040	31	30	29	28	27	26	25	24	23	22	21	20	19	18	17	16	15	14	13	12	11	10	9	8	7	6	5	4	3	2	1	0																		
Reset																	0	0	0	0	0	0	0	0	0	0	0	0	0	0	0	0	0	0	0	0	0	0	0	0	0	0	0	0	0	0	0			
Access																	R	R	R	R	R	R	R	R	R	R	R	R	R	R	R	R	R	R	R	R	R	R	R	R	R	R	R	R	R	R	R	R	R	R
Name																	CCF	SSM	MPAF	FERR	PERR	TXUF	TXOF	RXUF	RXOF	RXFULL	RXDATAV	TXBL	TXC																					

Bit	Name	Reset	Access	Description
31:13	Reserved	To ensure compatibility with future devices, always write bits to 0. More information in Section 2.1 (p. 3)		
12	CCF	0	R	Collision Check Fail Interrupt Flag Set when a collision check notices an error in the transmitted data.
11	SSM	0	R	Slave-Select In Master Mode Interrupt Flag Set when the device is selected as a slave when in master mode.
10	MPAF	0	R	Multi-Processor Address Frame Interrupt Flag Set when a multi-processor address frame is detected.
9	FERR	0	R	Framing Error Interrupt Flag Set when a frame with a framing error is received while RXBLOCK is cleared.
8	PERR	0	R	Parity Error Interrupt Flag Set when a frame with a parity error (asynchronous mode only) is received while RXBLOCK is cleared.
7	TXUF	0	R	TX Underflow Interrupt Flag Set when operating as a synchronous slave, no data is available in the transmit buffer when the master starts transmission of a new frame.
6	TXOF	0	R	TX Overflow Interrupt Flag Set when a write is done to the transmit buffer while it is full. The data already in the transmit buffer is preserved.
5	RXUF	0	R	RX Underflow Interrupt Flag Set when trying to read from the receive buffer when it is empty.
4	RXOF	0	R	RX Overflow Interrupt Flag

Bit	Name	Reset	Access	Description
				Set when data is incoming while the receive shift register is full. The data previously in the shift register is lost.
3	RXFULL	0	R	RX Buffer Full Interrupt Flag Set when the receive buffer becomes full.
2	RXDATAV	0	R	RX Data Valid Interrupt Flag Set when data becomes available in the receive buffer.
1	TXBL	1	R	TX Buffer Level Interrupt Flag Set when buffer becomes empty if TXBIL is set, or when buffer goes from full to half-full if TXBIL is cleared
0	TXC	0	R	TX Complete Interrupt Flag This interrupt is used after a transmission when both the TX buffer and shift register are empty.

16.5.18 USARTn_IFS - Interrupt Flag Set Register

Offset	Bit Position																																																	
0x044	31	30	29	28	27	26	25	24	23	22	21	20	19	18	17	16	15	14	13	12	11	10	9	8	7	6	5	4	3	2	1	0																		
Reset																					0	0	0	0	0	0	0	0	0	0	0	0	0	0	0	0	0	0	0	0	0	0	0	0	0	0	0	0	0	0
Access																					W1	W1	W1	W1	W1	W1	W1	W1	W1	W1	W1	W1	W1	W1	W1	W1	W1	W1	W1	W1	W1	W1	W1	W1	W1	W1	W1	W1	W1	W1
Name																					CCF	SSM	MPAF	FERR	PERR	TXUF	TXOF	RXUF	RXOF	RXFULL																				TXC

Bit	Name	Reset	Access	Description
31:13	<i>Reserved</i>	<i>To ensure compatibility with future devices, always write bits to 0. More information in Section 2.1 (p. 3)</i>		
12	CCF	0	W1	Set Collision Check Fail Interrupt Flag Write to 1 to set the CCF interrupt flag.
11	SSM	0	W1	Set Slave-Select in Master mode Interrupt Flag Write to 1 to set the SSM interrupt flag.
10	MPAF	0	W1	Set Multi-Processor Address Frame Interrupt Flag Write to 1 to set the MPAF interrupt flag.
9	FERR	0	W1	Set Framing Error Interrupt Flag Write to 1 to set the FERR interrupt flag.
8	PERR	0	W1	Set Parity Error Interrupt Flag Write to 1 to set the PERR interrupt flag.
7	TXUF	0	W1	Set TX Underflow Interrupt Flag Write to 1 to set the TXUF interrupt flag.
6	TXOF	0	W1	Set TX Overflow Interrupt Flag Write to 1 to set the TXOF interrupt flag.
5	RXUF	0	W1	Set RX Underflow Interrupt Flag Write to 1 to set the RXUF interrupt flag.
4	RXOF	0	W1	Set RX Overflow Interrupt Flag Write to 1 to set the RXOF interrupt flag.
3	RXFULL	0	W1	Set RX Buffer Full Interrupt Flag Write to 1 to set the RXFULL interrupt flag.
2:1	<i>Reserved</i>	<i>To ensure compatibility with future devices, always write bits to 0. More information in Section 2.1 (p. 3)</i>		
0	TXC	0	W1	Set TX Complete Interrupt Flag Write to 1 to set the TXC interrupt flag.

16.5.19 USARTn_IFC - Interrupt Flag Clear Register

Offset	Bit Position																																																		
	31	30	29	28	27	26	25	24	23	22	21	20	19	18	17	16	15	14	13	12	11	10	9	8	7	6	5	4	3	2	1	0																			
0x048																																																			
Reset																					0	0	0	0	0	0	0	0	0	0	0	0	0	0	0	0	0	0	0	0	0	0	0	0	0	0	0	0	0	0	
Access																					W1	W1	W1	W1	W1	W1	W1	W1	W1	W1	W1	W1	W1	W1	W1	W1	W1	W1	W1	W1	W1	W1	W1	W1	W1	W1	W1	W1	W1	W1	W1
Name																					CCF	SSM	MPAF	FERR	PERR	TXUF	TXOF	RXUF	RXOF	RXFULL																					TXC

Bit	Name	Reset	Access	Description
31:13	Reserved	To ensure compatibility with future devices, always write bits to 0. More information in Section 2.1 (p. 3)		
12	CCF	0	W1	Clear Collision Check Fail Interrupt Flag Write to 1 to clear the CCF interrupt flag.
11	SSM	0	W1	Clear Slave-Select In Master Mode Interrupt Flag Write to 1 to clear the SSM interrupt flag.
10	MPAF	0	W1	Clear Multi-Processor Address Frame Interrupt Flag Write to 1 to clear the MPAF interrupt flag.
9	FERR	0	W1	Clear Framing Error Interrupt Flag Write to 1 to clear the FERR interrupt flag.
8	PERR	0	W1	Clear Parity Error Interrupt Flag Write to 1 to clear the PERR interrupt flag.
7	TXUF	0	W1	Clear TX Underflow Interrupt Flag Write to 1 to clear the TXUF interrupt flag.
6	TXOF	0	W1	Clear TX Overflow Interrupt Flag Write to 1 to clear the TXOF interrupt flag.
5	RXUF	0	W1	Clear RX Underflow Interrupt Flag Write to 1 to clear the RXUF interrupt flag.
4	RXOF	0	W1	Clear RX Overflow Interrupt Flag Write to 1 to clear the RXOF interrupt flag.
3	RXFULL	0	W1	Clear RX Buffer Full Interrupt Flag Write to 1 to clear the RXFULL interrupt flag.
2:1	Reserved	To ensure compatibility with future devices, always write bits to 0. More information in Section 2.1 (p. 3)		
0	TXC	0	W1	Clear TX Complete Interrupt Flag Write to 1 to clear the TXC interrupt flag.

16.5.20 USARTn_IEN - Interrupt Enable Register

Offset	Bit Position																																																	
	31	30	29	28	27	26	25	24	23	22	21	20	19	18	17	16	15	14	13	12	11	10	9	8	7	6	5	4	3	2	1	0																		
0x04C																																																		
Reset																					0	0	0	0	0	0	0	0	0	0	0	0	0	0	0	0	0	0	0	0	0	0	0	0	0	0	0	0	0	
Access																					RW	RW	RW	RW	RW	RW	RW	RW	RW	RW	RW	RW	RW	RW	RW	RW	RW	RW	RW	RW	RW	RW	RW	RW	RW	RW	RW	RW	RW	RW
Name																					CCF	SSM	MPAF	FERR	PERR	TXUF	TXOF	RXUF	RXOF	RXFULL	RXDATAV	TXBL	TXC																	

Bit	Name	Reset	Access	Description
31:13	Reserved	To ensure compatibility with future devices, always write bits to 0. More information in Section 2.1 (p. 3)		
12	CCF	0	RW	Collision Check Fail Interrupt Enable Enable interrupt on collision check error detected.
11	SSM	0	RW	Slave-Select In Master Mode Interrupt Enable Enable interrupt on slave-select in master mode.
10	MPAF	0	RW	Multi-Processor Address Frame Interrupt Enable Enable interrupt on multi-processor address frame.
9	FERR	0	RW	Framing Error Interrupt Enable Enable interrupt on framing error.
8	PERR	0	RW	Parity Error Interrupt Enable Enable interrupt on parity error (asynchronous mode only).
7	TXUF	0	RW	TX Underflow Interrupt Enable Enable interrupt on TX underflow.
6	TXOF	0	RW	TX Overflow Interrupt Enable Enable interrupt on TX overflow.
5	RXUF	0	RW	RX Underflow Interrupt Enable Enable interrupt on RX underflow.
4	RXOF	0	RW	RX Overflow Interrupt Enable Enable interrupt on RX overflow.
3	RXFULL	0	RW	RX Buffer Full Interrupt Enable Enable interrupt on RX Buffer full.
2	RXDATAV	0	RW	RX Data Valid Interrupt Enable Enable interrupt on RX data.
1	TXBL	0	RW	TX Buffer Level Interrupt Enable Enable interrupt on TX buffer level.
0	TXC	0	RW	TX Complete Interrupt Enable Enable interrupt on TX complete.

16.5.21 USARTn_IRCTRL - IrDA Control Register

Offset	Bit Position																																																						
	31	30	29	28	27	26	25	24	23	22	21	20	19	18	17	16	15	14	13	12	11	10	9	8	7	6	5	4	3	2	1	0																							
0x050																									0																														
Reset																																																							
Access																									RW																														
Name																									IRPRSEN																														

Bit	Name	Reset	Access	Description
31:8	Reserved	To ensure compatibility with future devices, always write bits to 0. More information in Section 2.1 (p. 3)		
7	IRPRSEN	0	RW	IrDA PRS Channel Enable Enable the PRS channel selected by IRPRSSEL as input to IrDA module instead of TX.
6:4	IRPRSSEL	0x0	RW	IrDA PRS Channel Select A PRS can be used as input to the pulse modulator instead of TX. This value selects the channel to use.

Bit	Name	Reset	Access	Description
	Value	Mode		Description
	0	PRSCH0		PRS Channel 0 selected
	1	PRSCH1		PRS Channel 1 selected
	2	PRSCH2		PRS Channel 2 selected
	3	PRSCH3		PRS Channel 3 selected
	4	PRSCH4		PRS Channel 4 selected
	5	PRSCH5		PRS Channel 5 selected
	6	PRSCH6		PRS Channel 6 selected
	7	PRSCH7		PRS Channel 7 selected
3	IRFILT	0	RW	IrDA RX Filter Set to enable filter on IrDA demodulator.
	Value	Description		
	0	No filter enabled		
	1	Filter enabled. IrDA pulse must be high for at least 4 consecutive clock cycles to be detected		
2:1	IRPW	0x0	RW	IrDA TX Pulse Width Configure the pulse width generated by the IrDA modulator as a fraction of the configured USART bit period.
	Value	Mode		Description
	0	ONE		IrDA pulse width is 1/16 for OVS=0 and 1/8 for OVS=1
	1	TWO		IrDA pulse width is 2/16 for OVS=0 and 2/8 for OVS=1
	2	THREE		IrDA pulse width is 3/16 for OVS=0 and 3/8 for OVS=1
	3	FOUR		IrDA pulse width is 4/16 for OVS=0 and 4/8 for OVS=1
0	IREN	0	RW	Enable IrDA Module Enable IrDA module and rout USART signals through it.

16.5.22 USARTn_ROUTE - I/O Routing Register

Offset	Bit Position																																		
0x054	31	30	29	28	27	26	25	24	23	22	21	20	19	18	17	16	15	14	13	12	11	10	9	8	7	6	5	4	3	2	1	0			
Reset																									0x0							0	0	0	0
Access																									RW							RW	RW	RW	RW
Name																									LOCATION							CLKPEN	CSPEN	TXPEN	RXPEN

Bit	Name	Reset	Access	Description
31:10	Reserved	<i>To ensure compatibility with future devices, always write bits to 0. More information in Section 2.1 (p. 3)</i>		
9:8	LOCATION	0x0	RW	I/O Location Decides the location of the USART I/O pins.
	Value	Mode		Description
	0	LOC0		Location 0
	1	LOC1		Location 1
	2	LOC2		Location 2
	3	LOC3		Location 3
7:4	Reserved	<i>To ensure compatibility with future devices, always write bits to 0. More information in Section 2.1 (p. 3)</i>		
3	CLKPEN	0	RW	CLK Pin Enable When set, the CLK pin of the USART is enabled.
	Value	Description		
	0	The USn_CLK pin is disabled		

Bit	Name	Reset	Access	Description
	Value	Description		
	1	The USn_CLK pin is enabled		
2	CSPEN	0	RW	CS Pin Enable
	When set, the CS pin of the USART is enabled.			
	Value	Description		
	0	The USn_CS pin is disabled		
	1	The USn_CS pin is enabled		
1	TXPEN	0	RW	TX Pin Enable
	When set, the TX/MOSI pin of the USART is enabled			
	Value	Description		
	0	The U(S)n_TX (MOSI) pin is disabled		
	1	The U(S)n_TX (MOSI) pin is enabled		
0	RXPEN	0	RW	RX Pin Enable
	When set, the RX/MISO pin of the USART is enabled.			
	Value	Description		
	0	The U(S)n_RX (MISO) pin is disabled		
	1	The U(S)n_RX (MISO) pin is enabled		

17 UART - Universal Asynchronous Receiver/Transmitter

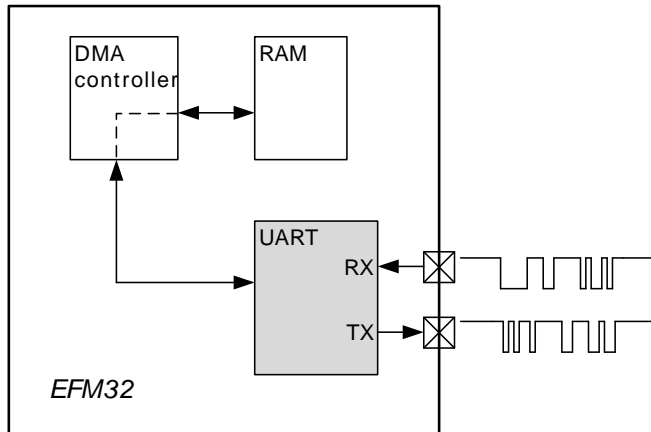
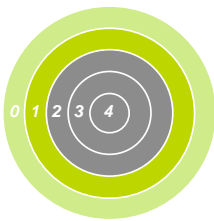

Quick Facts

What?

The UART is capable of high-speed asynchronous serial communication.

Why?

Serial communication is frequently used in embedded systems and the UART allows efficient communication with a wide range of external devices.

How?

The UART has a wide selection of operating modes, frame formats and baud rates. The multi-processor mode allows the UART to remain idle when not addressed. Triple buffering and DMA support makes high data-rates possible with minimal CPU intervention and it is possible to transmit and receive large frames while the MCU remains in EM1.

17.1 Introduction

The Universal Asynchronous serial Receiver and Transmitter (UART) is a very flexible serial I/O module. It supports full- and half-duplex asynchronous UART communication.

17.2 Features

- Full duplex and half duplex
- Separate TX / RX enable
- Separate receive / transmit 2-level buffers, with additional separate shift registers
- Programmable baud rate, generated as a fractional division from the peripheral clock (HFPERCLK)
- Max bit-rate
 - UART standard mode, peripheral clock rate / 16
 - UART FAST mode, peripheral clock rate / 8
- Asynchronous mode supports
 - Majority vote baud-reception
 - False start-bit detection
 - Break generation/detection
 - Multi-processor mode
- Configurable number of data bits, 8-9 (plus the parity bit, if enabled)
 - HW parity bit generation and check
- Configurable number of stop bits in asynchronous mode: 0.5, 1, 1.5, 2
- HW collision detection
- Multi-processor mode
- Separate interrupt vectors for receive and transmit interrupts
- Loopback mode
 - Half duplex communication

- Communication debugging
- PRS can trigger transmissions
- Full DMA support

17.3 Functional Description

The UART is functionally equivalent to the USART with the exceptions defined in Table 17.1 (p. 218) . The register map and register descriptions are equal to those of the USART. See the USART chapter for detailed information on the operation of the UART.

Table 17.1. UART Limitations

Feature	Limitations
Synchronous operation	Not available. SYNC, CSMA, CSINV, CPOL and CPHA in USARTn_CTRL, and MASTEREN in USARTn_STATUS are always 0.
Transmission direction	Always LSB first. MSBF in USARTn_CTRL is always 0.
Chip-select	Not available. AUTOCS in USARTn_CTRL is always 0.
SmartCard mode	Not available. SCMODE in USARTn_CTRL is always 0.
Frame size	Limited to 8-9 databits. Other configurations of DATABITS in USARTn_FRAME are not possible.
IrDA	Not available. IREN in USARTn_IRCTRL is always 0.

17.4 Register Description

The register description of the UART is equivalent to the register description of the USART except the limitations mentioned in Table 17.1 (p. 218) . See the USART chapter for complete information.

17.5 Register Map

The register map of the UART is equivalent to the register map of the USART. See the USART chapter for complete information.

18 LEUART - Low Energy Universal Asynchronous Receiver/Transmitter

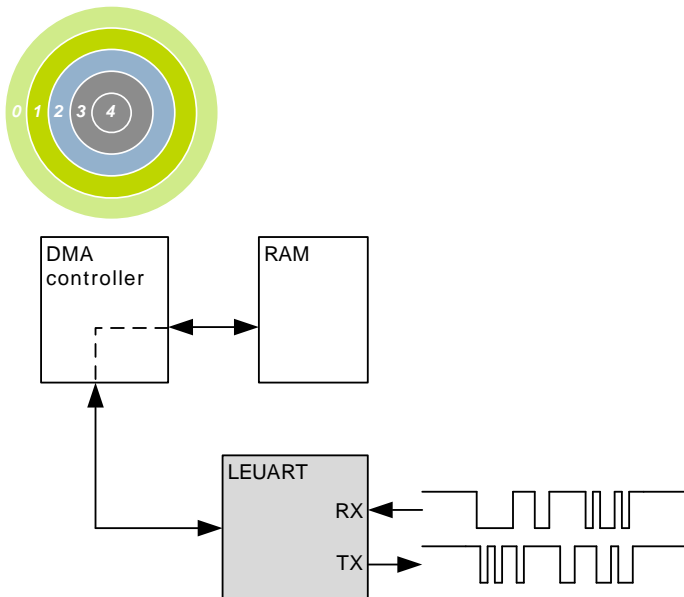

Quick Facts

What?

The LEUART provides full UART communication using a low frequency 32.768 kHz clock, and has special features for communication without CPU intervention.

Why?

It allows UART communication to be performed in low energy modes, using only a few μA during active communication and only 150 nA when waiting for incoming data.

How?

A low frequency clock signal allows communication with less energy. Using DMA, the LEUART can transmit and receive data with minimal CPU intervention. Special UART-frames can be configured to help control the data flow, further automating data transmission.

18.1 Introduction

The unique LEUART[™], the Low Energy UART, is a UART that allows two-way UART communication on a strict power budget. Only a 32.768 kHz clock is needed to allow UART communication up to 9600 baud/s.

Even when the EFM is in low energy mode EM2 (with most core functionality turned off), the LEUART can wait for an incoming UART frame while having an extremely low energy consumption. When a UART frame is completely received, the CPU can quickly be woken up. Alternatively, multiple frames can be transferred via the Direct Memory Access (DMA) module into RAM memory before waking up the CPU.

Received data can optionally be blocked until a configurable start frame is detected. A signal frame can be configured to generate an interrupt to indicate e.g. the end of a data transmission. The start frame and signal frame can be used in combination for instance to handle higher level communication protocols.

Similarly, data can be transmitted in EM2 either on a frame-by-frame basis with data from the CPU or through use of the DMA.

The LEUART includes all necessary hardware support to make asynchronous serial communication possible with minimum of software intervention and energy consumption.

18.2 Features

- Low energy asynchronous serial communications
- Full/half duplex communication
- Separate TX / RX enable
- Separate double buffered transmit buffer and receive buffer

- Programmable baud rate, generated as a fractional division of the LFBCLK
 - Supports baud rates from 300 baud/s to 9600 baud/s
- Can use a high frequency clock source for even higher baud rates
- Configurable number of data bits: 8 or 9 (plus parity bit, if enabled)
- Configurable parity: off, even or odd
 - HW parity bit generation and check
- Configurable number of stop bits, 1 or 2
- Capable of sleep-mode wakeup on received frame
 - Either wake-up on any received byte or
 - Wake up only on specified start and signal frames
- Supports transmission and reception in EM0, EM1 and EM2 with
 - Full DMA support
 - Specified start-byte can start reception automatically
- IrDA modulator (pulse generator, pulse extender)
- Multi-processor mode
- Loopback mode
 - Half duplex communication
 - Communication debugging

18.3 Functional Description

An overview of the LEUART module is shown in Figure 18.1 (p. 220) .

Figure 18.1. LEUART Overview

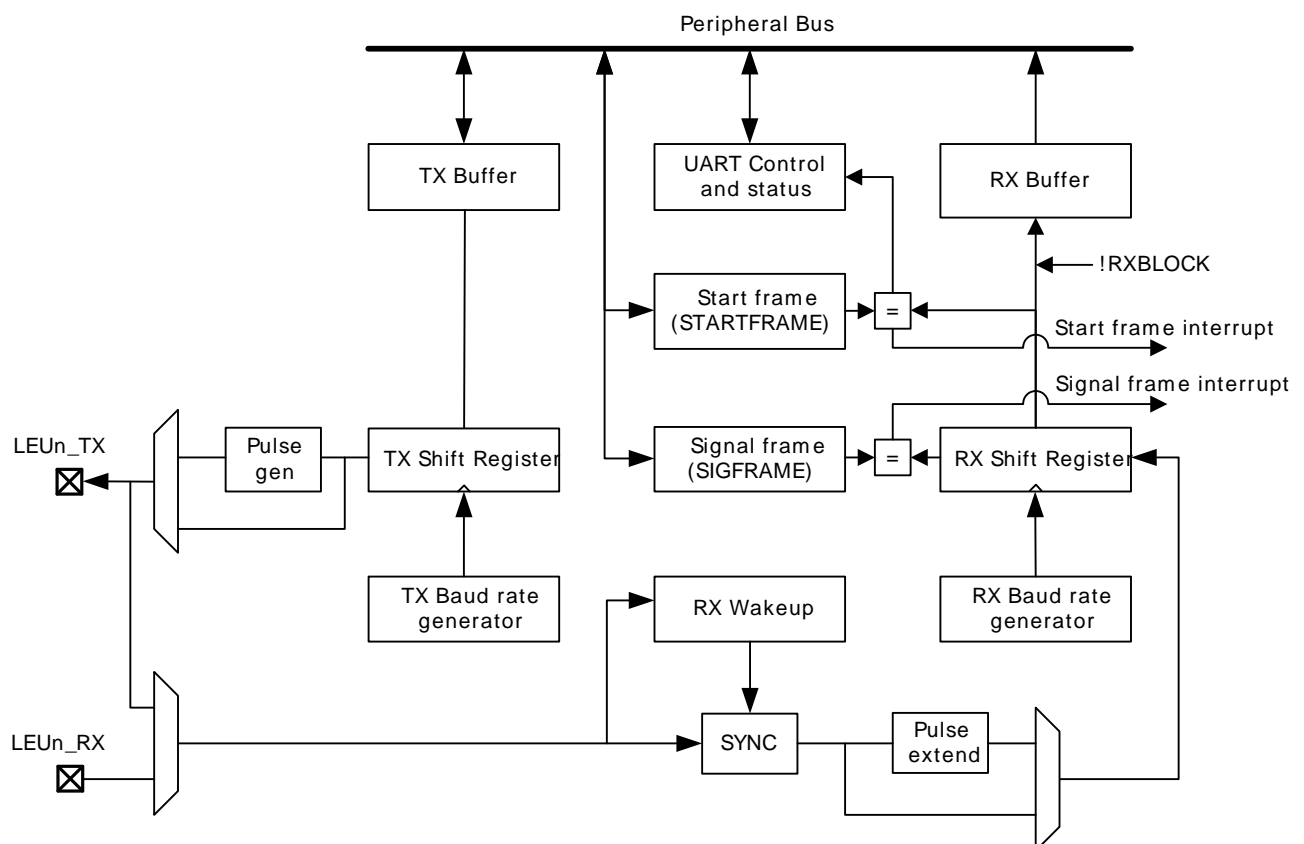

18.3.1 Frame Format

The frame format used by the LEUART consists of a set of data bits in addition to bits for synchronization and optionally a parity bit for error checking. A frame starts with one start-bit (S), where the line is driven

low for one bit-period. This signals the start of a frame, and is used for synchronization. Following the start bit are 8 or 9 data bits and an optional parity bit. The data is transmitted with the least significant bit first. Finally, a number of stop-bits, where the line is driven high, end the frame. The frame format is shown in Figure 18.2 (p. 221) .

Figure 18.2. LEUART Asynchronous Frame Format

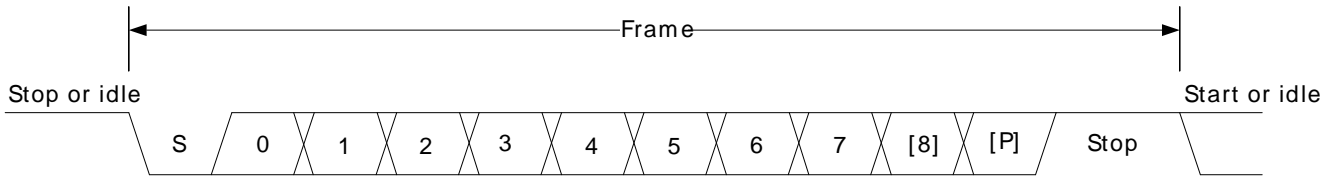

The number of data bits in a frame is set by DATABITS in LEUARTn_CTRL, and the number of stop-bits is set by STOPBITS in LEUARTn_CTRL. Whether or not a parity bit should be included, and whether it should be even or odd is defined by PARITY in LEUARTn_CTRL. For communication to be possible, all parties of an asynchronous transfer must agree on the frame format being used.

The frame format used by the LEUART can be inverted by setting INV in LEUARTn_CTRL. This affects the entire frame, resulting in a low idle state, a high start-bit, inverted data and parity bits, and low stop-bits. INV should only be changed while the receiver is disabled.

18.3.1.1 Parity Bit Calculation and Handling

Hardware automatically inserts parity bits into outgoing frames and checks the parity bits of incoming frames. The possible parity modes are defined in Table 18.1 (p. 221) . When even parity is chosen, a parity bit is inserted to make the number of high bits (data + parity) even. If odd parity is chosen, the parity bit makes the total number of high bits odd. When parity bits are disabled, which is the default configuration, the parity bit is omitted.

Table 18.1. LEUART Parity Bit

PARITY [1:0]	Description
00	No parity (default)
01	Reserved
10	Even parity
11	Odd parity

See Section 18.3.5.4 (p. 226) for more information on parity bit handling.

18.3.2 Clock Source

The LEUART clock source is selected by the LFB bit field the CMU_LFCLKSEL register. The clock is prescaled by the LEUARTn bitfield in the CMU_LFBPRESC0 register and enabled by the LEUARTn bit in the CMU_LFBCLKEN0.

To use this module, the LE interface clock must be enabled in CMU_HFCORECLKEN0, in addition to the module clock.

18.3.3 Clock Generation

The LEUART clock defines the transmission and reception data rate. The clock generator employs a fractional clock divider to allow baud rates that are not attainable by integral division of the 32.768 kHz clock that drives the LEUART.

The clock divider used in the LEUART is a 12-bit value, with a 7-bit integral part and a 5-bit fractional part. The baud rate of the LEUART is given by :

LEUART Baud Rate Equation

$$br = fLEUARTn / (1 + LEUARTn_CLKDIV / 256) \quad (18.1)$$

where $fLEUARTn$ is the clock frequency supplied to the LEUART. The value of $LEUARTn_CLKDIV$ thus defines the baud rate of the LEUART. The integral part of the divider is right-aligned in the upper 24 bits of $LEUARTn_CLKDIV$ and the fractional part is left-aligned in the lower 8 bits. The divider is thus a 256th of $LEUARTn_CLKDIV$ as seen in the equation.

For a desired baud rate $br_{DESIREDD}$, $LEUARTn_CLKDIV$ can be calculated by using:

LEUART CLKDIV Equation

$$LEUARTn_CLKDIV = 256 \times (fLEUARTn / br_{DESIREDD} - 1) \quad (18.2)$$

Table 18.2 (p. 222) lists a set of desired baud rates and the closest baud rates reachable by the LEUART with a 32.768 kHz clocksource. It also shows the average baud rate error.

Table 18.2. LEUART Baud Rates

Desired baud rate [baud/s]	LEUARTn_CLKDIV	LEUARTn_CLKDIV/256	Actual baud rate [baud/s]	Error [%]
300	27704	108,21875	300,0217	0,01
600	13728	53,625	599,8719	-0,02
1200	6736	26,3125	1199,744	-0,02
2400	3240	12,65625	2399,487	-0,02
4800	1488	5,8125	4809,982	0,21
9600	616	2,40625	9619,963	0,21

18.3.4 Data Transmission

Data transmission is initiated by writing data to the transmit buffer using one of the methods described in Section 18.3.4.1 (p. 222). When the transmission shift register is empty and ready for new data, a frame from the transmit buffer is loaded into the shift register, and if the transmitter is enabled, transmission begins. When the frame has been transmitted, a new frame is loaded into the shift register if available, and transmission continues. If the transmit buffer is empty, the transmitter goes to an idle state, waiting for a new frame to become available. Transmission is enabled through the command register $LEUARTn_CMD$ by setting $TXEN$, and disabled by setting $TXDIS$. When the transmitter is disabled using $TXDIS$, any ongoing transmission is aborted, and any frame currently being transmitted is discarded. When disabled, the TX output goes to an idle state, which by default is a high value. Whether or not the transmitter is enabled at a given time can be read from $TXENS$ in $LEUARTn_STATUS$. After a transmission, when there is no more data in the shift register or transmit buffer, the TXC flag in $LEUARTn_STATUS$ and the TXC interrupt flag in $LEUARTn_IF$ are set, signaling that the transmitter is idle. The TXC status flag is cleared when a new byte becomes available for transmission, but the TXC interrupt flag must be cleared by software.

18.3.4.1 Transmit Buffer Operation

A frame can be loaded into the transmit buffer by writing to $LEUARTn_TXDATA$ or $LEUARTn_TXDATA_X$. Using $LEUARTn_TXDATA$ allows 8 bits to be written to the buffer. If 9 bit frames are used, the 9th bit will in that case be set to the value of $BIT8DV$ in $LEUARTn_CTRL$. To set the 9th bit directly and/or use transmission control, $LEUARTn_TXDATA_X$ must be used. When writing data to the transmit buffer

using LEUARTn_TXDATAx, the 9th bit written to LEUARTn_TXDATAx overrides the value in BIT8DV, and alone defines the 9th bit that is transmitted if 9-bit frames are used.

If a write is attempted to the transmit buffer when it is not empty, the TXOF interrupt flag in LEUARTn_IF is set, indicating the overflow. The data already in the buffer is in that case preserved, and no data is written.

In addition to the interrupt flag TXC in LEUARTn_IF and the status flag TXC in LEUARTn_STATUS which are set when the transmitter becomes idle, TXBL in LEUARTn_STATUS and the TXBL interrupt flag in LEUARTn_IF are used to indicate the level of the transmit buffer. Whenever the transmit buffer becomes empty, these flags are set high. Both the TXBL status flag and the TXBL interrupt flag are cleared automatically when data is written to the transmit buffer.

The transmit buffer, including the TX shift register can be cleared by setting command bit CLEAR_TX in LEUARTn_CMD. This will prevent the LEUART from transmitting the data in the buffer and shift register, and will make them available for new data. Any frame currently being transmitted will not be aborted. Transmission of this frame will be completed. An overview of the operation of the transmitter is shown in Figure 18.3 (p. 223) .

Figure 18.3. LEUART Transmitter Overview

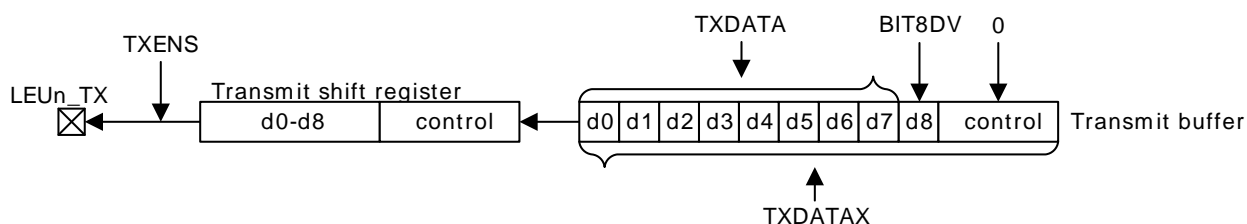

18.3.4.2 Frame Transmission Control

The transmission control bits, which can be written using LEUARTn_TXDATAx, affect the transmission of the written frame. The following options are available:

- **Generate break:** By setting WBREAK, the output will be held low during the first stop-bit period to generate a framing error. A receiver that supports break detection detects this state, allowing it to be used e.g. for framing of larger data packets. The line is driven high for one baud period before the next frame is transmitted so the next start condition can be identified correctly by the recipient. Continuous breaks lasting longer than an UART frame are thus not supported by the LEUART. GPIO can be used for this. Note that when AUTOTRI in LEUARTn_CTRL is used, the transmitter is not tristated before the high-bit after the break has been transmitted.
- **Disable transmitter after transmission:** If TXDISAT is set, the transmitter is disabled after the frame has been fully transmitted.
- **Enable receiver after transmission:** If RXENAT is set, the receiver is enabled after the frame has been fully transmitted. It is enabled in time to detect a start-bit directly after the last stop-bit has been transmitted.

The transmission control bits in the LEUART cannot tristate the transmitter. This is performed automatically by hardware however, if AUTOTRI in LEUARTn_CTRL is set. See Section 18.3.7 (p. 228) for more information on half duplex operation.

18.3.4.3 Jitter in Transmitted Data

Internally the LEUART module uses only the positive edges of the 32.768 kHz clock (LFBCLK) for transmission and reception. Transmitted data will thus have jitter equal to the difference between the optimal data set-up location and the closest positive edge on the 32.768 kHz clock. The jitter in on the location data is set up by the transmitter will thus be no more than half a clock period according to the optimal set-up location. The jitter in the period of a single baud output by the transmitter will never be more than one clock period.

18.3.5 Data Reception

Data reception is enabled by setting RXEN in LEUARTn_CMD. When the receiver is enabled, it actively samples the input looking for a transition from high to low indicating the start baud of a new frame. When a start baud is found, reception of the new frame begins if the receive shift register is empty and ready for new data. When the frame has been received, it is pushed into the receive buffer, making the shift register ready for another frame of data, and the receiver starts looking for another start baud. If the receive buffer is full, the received frame remains in the shift register until more space in the receive buffer is available.

If an incoming frame is detected while both the receive buffer and the receive shift register are full, the data in the receive shift register is overwritten, and the RXOF interrupt flag in LEUARTn_IF is set to indicate the buffer overflow.

The receiver can be disabled by setting the command bit RXDIS in LEUARTn_CMD. Any frame currently being received when the receiver is disabled is discarded. Whether or not the receiver is enabled at a given time can be read out from RXENS in LEUARTn_STATUS.

18.3.5.1 Receive Buffer Operation

When data becomes available in the receive buffer, the RXDATAV flag in LEUARTn_STATUS and the RXDATAV interrupt flag in LEUARTn_IF are set. Both the RXDATAV status flag and the RXDATAV interrupt flag are cleared by hardware when data is no longer available, i.e. when data has been read out of the buffer.

Data can be read from receive buffer using either LEUARTn_RXDATA or LEUARTn_RXDATA_X. LEUARTn_RXDATA gives access to the 8 least significant bits of the received frame, while LEUARTn_RXDATA_X must be used to get access to the 9th, most significant bit. The latter register also contains status information regarding the frame.

When a frame is read from the receive buffer using LEUARTn_RXDATA or LEUARTn_RXDATA_X, the frame is removed from the buffer, making room for a new one. If an attempt is done to read more frames from the buffer than what is available, the RXUF interrupt flag in LEUARTn_IF is set to signal the underflow, and the data read from the buffer is undefined.

Frames can also be read from the receive buffer without removing the data by using LEUARTn_RXDATA_XP, which gives access to the frame in the buffer including control bits. Data read from this register when the receive buffer is empty is undefined. No underflow interrupt is generated by a read using LEUARTn_RXDATA_XP, i.e. the RXUF interrupt flag is never set as a result of reading from LEUARTn_RXDATA_XP.

An overview of the operation of the receiver is shown in Figure 18.4 (p. 225) .

Figure 18.4. LEUART Receiver Overview

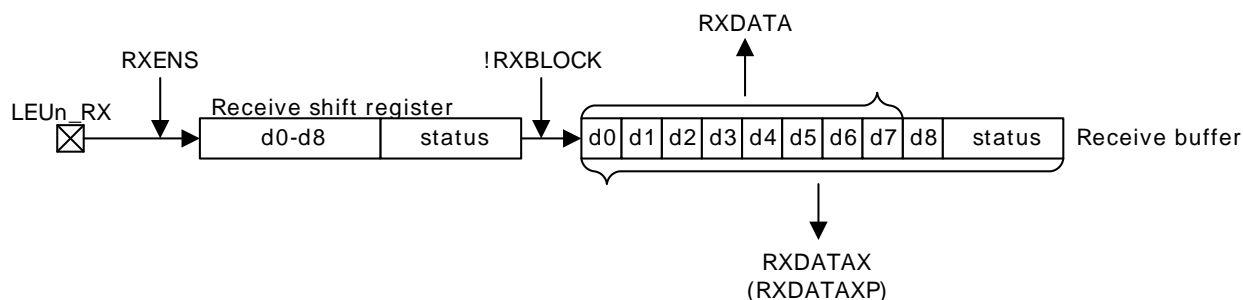

18.3.5.2 Blocking Incoming Data

When using hardware frame recognition, as detailed in Section 18.3.5.6 (p. 226), Section 18.3.5.7 (p. 227), and Section 18.3.5.8 (p. 227), it is necessary to be able to let the receiver sample incoming frames without passing the frames to software by loading them into the receive buffer. This is accomplished by blocking incoming data.

Incoming data is blocked as long as `RXBLOCK` in `LEUARTn_STATUS` is set. When blocked, frames received by the receiver will not be loaded into the receive buffer, and software is not notified by the `RXDATAV` bit in `LEUARTn_STATUS` or the `RXDATAV` interrupt flag in `LEUARTn_IF` at their arrival. For data to be loaded into the receive buffer, `RXBLOCK` must be cleared in the instant a frame is fully received by the receiver. `RXBLOCK` is set by setting `RXBLOCKEN` in `LEUARTn_CMD` and disabled by setting `RXBLOCKDIS` also in `LEUARTn_CMD`. There are two exceptions where data is loaded into the receive buffer even when `RXBLOCK` is set. The first is when an address frame is received when in operating in multi-processor mode as shown in Section 18.3.5.8 (p. 227). The other case is when receiving a start-frame when `SFUBRX` in `LEUARTn_CTRL` is set; see Section 18.3.5.6 (p. 226).

Frames received containing framing or parity errors will not result in the `FERR` and `PERR` interrupt flags in `LEUARTn_IF` being set while `RXBLOCK` is set. Hardware recognition is not applied to these erroneous frames, and they are silently discarded.

Note

If a frame is received while `RXBLOCK` in `LEUARTn_STATUS` is cleared, but stays in the receive shift register because the receive buffer is full, the received frame will be loaded into the receive buffer when space becomes available even if `RXBLOCK` is set at that time.

The overflow interrupt flag `RXOF` in `LEUARTn_IF` will be set if a frame in the receive shift register, waiting to be loaded into the receive buffer is overwritten by an incoming frame even though `RXBLOCK` is set.

18.3.5.3 Data Sampling

The receiver samples each incoming baud as close as possible to the middle of the baud-period. Except for the start-bit, only a single sample is taken of each of the incoming bauds.

The length of a baud-period is given by $1 + \text{LEUARTn_CLKDIV}/256$, as a number of 32.768 kHz clock periods. Let the clock cycle where a start-bit is first detected be given the index 0. The optimal sampling point for each baud in the UART frame is then given by the following equation:

LEUART Optimal Sampling Point

$$S_{\text{opt}}(n) = n (1 + \text{LEUARTn_CLKDIV}/256) + \text{CLKDIV}/512 \quad (18.3)$$

where n is the bit-index.

Since samples are only done on the positive edges of the 32.768 kHz clock, the actual samples are performed on the closest positive edge, i.e. the edge given by the following equation:

LEUART Actual Sampling Point

$$S(n) = \text{floor}(n \times (1 + \text{LEUARTn_CLKDIV}/256) + \text{LEUARTn_CLKDIV}/512) \quad (18.4)$$

The sampling location will thus have jitter according to difference between S_{opt} and S . The start-bit is found at $n=0$, then follows the data bits, any parity bit, and the stop bits.

If the value of the start-bit is found to be high, then the start-bit is discarded, and the receiver waits for a new start-bit.

18.3.5.4 Parity Error

When the parity bit is enabled, a parity check is automatically performed on incoming frames. When a parity error is detected in a frame, the data parity error bit PERR in the frame is set, as well as the interrupt flag PERR. Frames with parity errors are loaded into the receive buffer like regular frames.

PERR can be accessed by reading the frame from the receive buffer using the LEUARTn_RXDATA register.

18.3.5.5 Framing Error and Break Detection

A framing error is the result of a received frame where the stop bit was sampled to a value of 0. This can be the result of noise and baud rate errors, but can also be the result of a break generated by the transmitter on purpose.

When a framing error is detected, the framing error bit FERR in the received frame is set. The interrupt flag FERR in LEUARTn_IF is also set. Frames with framing errors are loaded into the receive buffer like regular frames.

FERR can be accessed by reading the frame from the receive buffer using the LEUARTn_RXDATA or LEUARTn_RXDATA_P registers.

18.3.5.6 Programmable Start Frame

The LEUART can be configured to start receiving data when a special start frame is detected on the input. This can be useful when operating in low energy modes, allowing other devices to gain the attention of the LEUART by transmitting a given frame.

When SFUBRX in LEUARTn_CTRL is set, an incoming frame matching the frame defined in LEUARTn_STARTFRAME will result in RXBLOCK in LEUARTn_STATUS being cleared. This can be used to enable reception when a specified start frame is detected. If the receiver is enabled and blocked, i.e. RXENS and RXBLOCK in LEUARTn_STATUS are set, the receiver will receive all incoming frames, but unless an incoming frame is a start frame it will be discarded and not loaded into the receive buffer. When a start frame is detected, the block is cleared, and frames received from that point, including the start frame, are loaded into the receive buffer.

An incoming start frame results in the STARTF interrupt flag in LEUARTn_IF being set, regardless of the value of SFUBRX in LEUARTn_CTRL. This allows an interrupt to be made when the start frame is detected.

When 8 data-bit frame formats are used, only the 8 least significant bits of LEUARTn_STARTFRAME are compared to incoming frames. The full length of LEUARTn_STARTFRAME is used when operating with frames consisting of 9 data bits.

Note

The receiver must be enabled for start frames to be detected. In addition, a start frame with a parity error or framing error is not detected as a start frame.

18.3.5.7 Programmable Signal Frame

As well as the configurable start frame, a special signal frame can be specified. When a frame matching the frame defined in LEUARTn_SIGFRAME is detected by the receiver, the SIGF interrupt flag in LEUARTn_IF is set. As for start frame detection, the receiver must be enabled for signal frames to be detected.

One use of the programmable signal frame is to signal the end of a multi-frame message transmitted to the LEUART. An interrupt will then be triggered when the packet has been completely received, allowing software to process it. Used in conjunction with the programmable start frame and DMA, this makes it possible for the LEUART to automatically begin the reception of a packet on a specified start frame, load the entire packet into memory, and give an interrupt when reception of a packet has completed. The device can thus wait for data packets in EM2, and only be woken up when a packet has been completely received.

A signal frame with a parity error or framing error is not detected as a signal frame.

18.3.5.8 Multi-Processor Mode

To simplify communication between multiple processors and maintain compatibility with the USART, the LEUART supports a multi-processor mode. In this mode the 9th data bit in each frame is used to indicate whether the content of the remaining 8 bits is data or an address.

When multi-processor mode is enabled, an incoming 9-bit frame with the 9th bit equal to the value of MPAB in LEUARTn_CTRL is identified as an address frame. When an address frame is detected, the MPAF interrupt flag in LEUARTn_IF is set, and the address frame is loaded into the receive register. This happens regardless of the value of RXBLOCK in LEUARTn_STATUS.

Multi-processor mode is enabled by setting MPM in LEUARTn_CTRL. The mode can be used in buses with multiple slaves, allowing the slaves to be addressed using the special address frames. An addressed slave, which was previously blocking reception using RXBLOCK, would then unblock reception, receive a message from the bus master, and then block reception again, waiting for the next message. See the USART for a more detailed example.

Note

The programmable start frame functionality can be used for automatic address matching, enabling reception on a correctly configured incoming frame.

An address frame with a parity error or a framing error is not detected as an address frame.

18.3.6 Loopback

The LEUART receiver samples LEUn_RX by default, and the transmitter drives LEUn_TX by default. This is not the only configuration however. When LOOPBK in LEUARTn_CTRL is set, the receiver is connected to the LEUn_TX pin as shown in Figure 18.5 (p. 228). This is useful for debugging, as the LEUART can receive the data it transmits, but it is also used to allow the LEUART to read and write to the same pin, which is required for some half duplex communication modes. In this mode, the LEUn_TX pin must be enabled as an output in the GPIO.

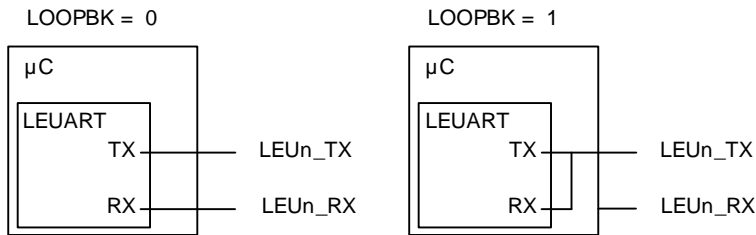
Figure 18.5. LEUART Local Loopback

18.3.7 Half Duplex Communication

When doing full duplex communication, two data links are provided, making it possible for data to be sent and received at the same time. In half duplex mode, data is only sent in one direction at a time. There are several possible half duplex setups, as described in the following sections.

18.3.7.1 Single Data-link

In this setup, the LEUART both receives and transmits data on the same pin. This is enabled by setting LOOPBK in LEUARTn_CTRL, which connects the receiver to the transmitter output. Because they are both connected to the same line, it is important that the LEUART transmitter does not drive the line when receiving data, as this would corrupt the data on the line.

When communicating over a single data-link, the transmitter must thus be tristated whenever not transmitting data. If AUTOTRI in LEUARTn_CTRL is set, the LEUART automatically tristates LEUn_TX whenever the transmitter is inactive. It is then the responsibility of the software protocol to make sure the transmitter is not transmitting data whenever incoming data is expected.

The transmitter can also be tristated from software by configuring the GPIO pin as an input and disabling the LEUART output on LEUn_TX.

Note

Another way to tristate the transmitter is to enable wired-and or wired-or mode in GPIO. For wired-and mode, outputting a 1 will be the same as tristating the output, and for wired-or mode, outputting a 0 will be the same as tristating the output. This can only be done on buses with a pull-up or pull-down resistor respectively.

18.3.7.2 Single Data-link with External Driver

Some communication schemes, such as RS-485 rely on an external driver. Here, the driver has an extra input which enables it, and instead of Tristating the transmitter when receiving data, the external driver must be disabled. The USART has hardware support for automatically turning the driver on and off. When using the LEUART in such a setup, the driver must be controlled by a GPIO. Figure 18.6 (p. 228) shows an example configuration using an external driver.

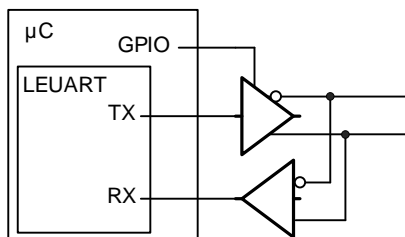
Figure 18.6. LEUART Half Duplex Communication with External Driver

18.3.7.3 Two Data-links

Some limited devices only support half duplex communication even though two data links are available. In this case software is responsible for making sure data is not transmitted when incoming data is expected.

18.3.8 Transmission Delay

By configuring TXDELAY in LEUARTn_CTRL, the transmitter can be forced to wait a number of bit-periods from it is ready to transmit data, to it actually transmits the data. This delay is only applied to the first frame transmitted after the transmitter has been idle. When transmitting frames back-to-back the delay is not introduced between the transmitted frames.

This is useful on half duplex buses, because the receiver always returns received frames to software during the first stop-bit. The bus may still be driven for up to 3 baud periods, depending on the current frame format. Using the transmission delay, a transmission can be started when a frame is received, and it is possible to make sure that the transmitter does not begin driving the output before the frame on the bus is completely transmitted.

18.3.9 DMA Support

The LEUART has full DMA support in energy modes EM0 – EM2. The DMA controller can write to the transmit buffer using the registers LEUARTn_TXDATA and LEUARTn_TXDATA_X, and it can read from receive buffer using the registers LEUARTn_RXDATA and LEUARTn_RXDATA_X. This enables single byte transfers and 9 bit data + control/status bits transfers both to and from the LEUART. The DMA will start up the HFRCO and run from this when it is waken by the LEUART in EM2. The HFRCO is disabled once the transaction is done.

A request for the DMA controller to read from the receive buffer can come from one of the following sources:

- Receive buffer full

A write request can come from one of the following sources:

- Transmit buffer and shift register empty. No data to send.
- Transmit buffer empty

In some cases, it may be sensible to temporarily stop DMA access to the LEUART when a parity or framing error has occurred. This is enabled by setting ERRSDMA in LEUARTn_CTRL. When this bit is set, the DMA controller will not get requests from the receive buffer if a framing error or parity error is detected in the received byte. The ERRSDMA bit applies only to the RX DMA.

When operating in EM2, the DMA controller must be powered up in order to perform the transfer. This is automatically performed for read operations if RXDMAWU in LEUARTn_CTRL is set and for write operations if TXDMAWU in LEUARTn_CTRL is set. To make sure the DMA controller still transfers bits to and from the LEUART in low energy modes, these bits must thus be configured accordingly.

Note

When RXDMAWU or TXDMAWU is set, the system will not be able to go to EM2/EM3 before all related LEUART DMA requests have been processed. This means that if RXDMAWU is set and the LEUART receives a frame, the system will not be able to go to EM2/EM3 before the frame has been read from the LEUART. In order for the system to go to EM2 during the last byte transmission, LEUARTn_CTRL_TXDMAWU must be cleared in the DMA interrupt service routine. This is because TXBL will be high during that last byte transfer.

18.3.10 Pulse Generator/ Pulse Extender

The LEUART has an optional pulse generator for the transmitter output, and a pulse extender on the receiver input. These are enabled by setting PULSEEN in LEUARTn_PULSECTRL, and with INV in LEUARTn_CTRL set, they will change the output/input format of the LEUART from NRZ to RZI as shown in Figure 18.7 (p. 230) .

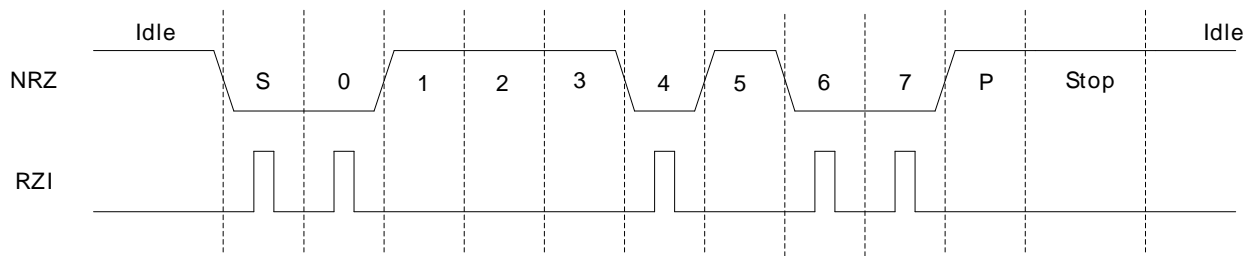
Figure 18.7. LEUART - NRZ vs. RZI

If PULSESEN in LEUARTn_PULSECTRL is set while INV in LEUARTn_CTRL is cleared, the output waveform will like RZI shown in Figure 18.7 (p. 230) , only inverted.

The width of the pulses from the pulse generator can be configured using PULSEW in LEUARTn_PULSECTRL. The generated pulse width is PULSEW + 1 cycles of the 32.768 kHz clock, which makes pulse width from 31.25µs to 500µs possible.

Since the incoming signal is only sampled on positive clock edges, the width of the incoming pulses must be at least two 32.768 kHz clock periods wide for reliable detection by the LEUART receiver. They must also be shorter than half a UART baud period.

At 2400 baud/s or lower, the pulse generator is able to generate RZI pulses compatible with the IrDA physical layer specification. The external IrDA device must generate pulses of sufficient length for successful two-way communication.

18.3.10.1 Interrupts

The interrupts generated by the LEUART are combined into one interrupt vector. If LEUART interrupts are enabled, an interrupt will be made if one or more of the interrupt flags in LEUARTn_IF and their corresponding bits in LEUART_IEN are set.

18.3.11 Register access

Since this module is a Low Energy Peripheral, and runs off a clock which is asynchronous to the HFCORECLK, special considerations must be taken when accessing registers. Please refer to Section 5.3 (p. 18) for a description on how to perform register accesses to Low Energy Peripherals.

18.4 Register Map

The offset register address is relative to the registers base address.

Offset	Name	Type	Description
0x000	LEUARTn_CTRL	RW	Control Register
0x004	LEUARTn_CMD	W1	Command Register
0x008	LEUARTn_STATUS	R	Status Register
0x00C	LEUARTn_CLKDIV	RW	Clock Control Register
0x010	LEUARTn_STARTFRAME	RW	Start Frame Register
0x014	LEUARTn_SIGFRAME	RW	Signal Frame Register
0x018	LEUARTn_RXDATAx	R	Receive Buffer Data Extended Register
0x01C	LEUARTn_RXDATA	R	Receive Buffer Data Register
0x020	LEUARTn_RXDATAxP	R	Receive Buffer Data Extended Peek Register
0x024	LEUARTn_TXDATAx	W	Transmit Buffer Data Extended Register
0x028	LEUARTn_TXDATA	W	Transmit Buffer Data Register
0x02C	LEUARTn_IF	R	Interrupt Flag Register
0x030	LEUARTn_IFS	W1	Interrupt Flag Set Register
0x034	LEUARTn_IFC	W1	Interrupt Flag Clear Register
0x038	LEUARTn_IEN	RW	Interrupt Enable Register
0x03C	LEUARTn_PULSECTRL	RW	Pulse Control Register
0x040	LEUARTn_FREEZE	RW	Freeze Register
0x044	LEUARTn_SYNCBUSY	R	Synchronization Busy Register
0x054	LEUARTn_ROUTE	RW	I/O Routing Register

18.5 Register Description

18.5.1 LEUARTn_CTRL - Control Register (Async Reg)

For more information about Asynchronous Registers please see Section 5.3 (p. 18) .

Offset	Bit Position																																																
0x000	31	30	29	28	27	26	25	24	23	22	21	20	19	18	17	16	15	14	13	12	11	10	9	8	7	6	5	4	3	2	1	0																	
Reset																	0x0	0	0	0	0	0	0	0	0	0	0	0	0	0	0	0	0	0	0	0	0	0	0	0	0	0	0	0	0	0	0	0	
Access																	RW	RW	RW	RW	RW	RW	RW	RW	RW	RW	RW	RW	RW	RW	RW	RW	RW	RW	RW	RW	RW	RW	RW	RW	RW	RW	RW	RW	RW	RW	RW	RW	RW
Name																	TXDELAY	TXDMAWU	RXDMAWU	BIT8DV	MPAB	MPM	SFUBRX	LOOPBK	ERRSDMA	INV	STOPBITS	PARITY	DATABITS	AUTOTRI																			

Bit	Name	Reset	Access	Description
31:16	Reserved	<i>To ensure compatibility with future devices, always write bits to 0. More information in Section 2.1 (p. 3)</i>		

15:14 TXDELAY 0x0 RW **TX Delay Transmission**

Configurable delay before new transfers. Frames sent back-to-back are not delayed.

Value	Mode	Description
0	NONE	Frames are transmitted immediately
1	SINGLE	Transmission of new frames are delayed by a single baud period
2	DOUBLE	Transmission of new frames are delayed by two baud periods
3	TRIPLE	Transmission of new frames are delayed by three baud periods

Bit	Name	Reset	Access	Description									
13	TXDMAWU	0	RW	TX DMA Wakeup Set to wake the DMA controller up when in EM2 and space is available in the transmit buffer.									
<table border="1"> <thead> <tr> <th>Value</th> <th>Description</th> </tr> </thead> <tbody> <tr> <td>0</td> <td>While in EM2, the DMA controller will not get requests about space being available in the transmit buffer</td> </tr> <tr> <td>1</td> <td>DMA is available in EM2 for the request about space available in the transmit buffer</td> </tr> </tbody> </table>					Value	Description	0	While in EM2, the DMA controller will not get requests about space being available in the transmit buffer	1	DMA is available in EM2 for the request about space available in the transmit buffer			
Value	Description												
0	While in EM2, the DMA controller will not get requests about space being available in the transmit buffer												
1	DMA is available in EM2 for the request about space available in the transmit buffer												
12	RXDMAWU	0	RW	RX DMA Wakeup Set to wake the DMA controller up when in EM2 and data is available in the receive buffer.									
<table border="1"> <thead> <tr> <th>Value</th> <th>Description</th> </tr> </thead> <tbody> <tr> <td>0</td> <td>While in EM2, the DMA controller will not get requests about data being available in the receive buffer</td> </tr> <tr> <td>1</td> <td>DMA is available in EM2 for the request about data in the receive buffer</td> </tr> </tbody> </table>					Value	Description	0	While in EM2, the DMA controller will not get requests about data being available in the receive buffer	1	DMA is available in EM2 for the request about data in the receive buffer			
Value	Description												
0	While in EM2, the DMA controller will not get requests about data being available in the receive buffer												
1	DMA is available in EM2 for the request about data in the receive buffer												
11	BIT8DV	0	RW	Bit 8 Default Value When 9-bit frames are transmitted, the default value of the 9th bit is given by BIT8DV. If TXDATA is used to write a frame, then the value of BIT8DV is assigned to the 9th bit of the outgoing frame. If a frame is written with TXDATAx however, the default value is overridden by the written value.									
10	MPAB	0	RW	Multi-Processor Address-Bit Defines the value of the multi-processor address bit. An incoming frame with its 9th bit equal to the value of this bit marks the frame as a multi-processor address frame.									
9	MPM	0	RW	Multi-Processor Mode Set to enable multi-processor mode.									
<table border="1"> <thead> <tr> <th>Value</th> <th>Description</th> </tr> </thead> <tbody> <tr> <td>0</td> <td>The 9th bit of incoming frames have no special function</td> </tr> <tr> <td>1</td> <td>An incoming frame with the 9th bit equal to MPAB will be loaded into the receive buffer regardless of RXBLOCK and will result in the MPAB interrupt flag being set</td> </tr> </tbody> </table>					Value	Description	0	The 9th bit of incoming frames have no special function	1	An incoming frame with the 9th bit equal to MPAB will be loaded into the receive buffer regardless of RXBLOCK and will result in the MPAB interrupt flag being set			
Value	Description												
0	The 9th bit of incoming frames have no special function												
1	An incoming frame with the 9th bit equal to MPAB will be loaded into the receive buffer regardless of RXBLOCK and will result in the MPAB interrupt flag being set												
8	SFUBRX	0	RW	Start-Frame Unblock RX Clears RXBLOCK when the start-frame is found in the incoming data. The start-frame is loaded into the receive buffer.									
<table border="1"> <thead> <tr> <th>Value</th> <th>Description</th> </tr> </thead> <tbody> <tr> <td>0</td> <td>Detected start-frames have no effect on RXBLOCK</td> </tr> <tr> <td>1</td> <td>When a start-frame is detected, RXBLOCK is cleared and the start-frame is loaded into the receive buffer</td> </tr> </tbody> </table>					Value	Description	0	Detected start-frames have no effect on RXBLOCK	1	When a start-frame is detected, RXBLOCK is cleared and the start-frame is loaded into the receive buffer			
Value	Description												
0	Detected start-frames have no effect on RXBLOCK												
1	When a start-frame is detected, RXBLOCK is cleared and the start-frame is loaded into the receive buffer												
7	LOOPBK	0	RW	Loopback Enable Set to connect receiver to LEUn_TX instead of LEUn_RX.									
<table border="1"> <thead> <tr> <th>Value</th> <th>Description</th> </tr> </thead> <tbody> <tr> <td>0</td> <td>The receiver is connected to and receives data from LEUn_RX</td> </tr> <tr> <td>1</td> <td>The receiver is connected to and receives data from LEUn_TX</td> </tr> </tbody> </table>					Value	Description	0	The receiver is connected to and receives data from LEUn_RX	1	The receiver is connected to and receives data from LEUn_TX			
Value	Description												
0	The receiver is connected to and receives data from LEUn_RX												
1	The receiver is connected to and receives data from LEUn_TX												
6	ERRSDMA	0	RW	Clear RX DMA On Error When set, RX DMA requests will be cleared on framing and parity errors.									
<table border="1"> <thead> <tr> <th>Value</th> <th>Description</th> </tr> </thead> <tbody> <tr> <td>0</td> <td>Framing and parity errors have no effect on DMA requests from the LEUART</td> </tr> <tr> <td>1</td> <td>RX DMA requests from the LEUART are disabled if a framing error or parity error occurs.</td> </tr> </tbody> </table>					Value	Description	0	Framing and parity errors have no effect on DMA requests from the LEUART	1	RX DMA requests from the LEUART are disabled if a framing error or parity error occurs.			
Value	Description												
0	Framing and parity errors have no effect on DMA requests from the LEUART												
1	RX DMA requests from the LEUART are disabled if a framing error or parity error occurs.												
5	INV	0	RW	Invert Input And Output Set to invert the output on LEUn_TX and input on LEUn_RX.									
<table border="1"> <thead> <tr> <th>Value</th> <th>Description</th> </tr> </thead> <tbody> <tr> <td>0</td> <td>A high value on the input/output is 1, and a low value is 0.</td> </tr> <tr> <td>1</td> <td>A low value on the input/output is 0, and a high value is 0.</td> </tr> </tbody> </table>					Value	Description	0	A high value on the input/output is 1, and a low value is 0.	1	A low value on the input/output is 0, and a high value is 0.			
Value	Description												
0	A high value on the input/output is 1, and a low value is 0.												
1	A low value on the input/output is 0, and a high value is 0.												
4	STOPBITS	0	RW	Stop-Bit Mode Determines the number of stop-bits used. Only used when transmitting data. The receiver only verifies that one stop bit is present.									
<table border="1"> <thead> <tr> <th>Value</th> <th>Mode</th> <th>Description</th> </tr> </thead> <tbody> <tr> <td>0</td> <td>ONE</td> <td>One stop-bit is transmitted with every frame</td> </tr> <tr> <td>1</td> <td>TWO</td> <td>Two stop-bits are transmitted with every frame</td> </tr> </tbody> </table>					Value	Mode	Description	0	ONE	One stop-bit is transmitted with every frame	1	TWO	Two stop-bits are transmitted with every frame
Value	Mode	Description											
0	ONE	One stop-bit is transmitted with every frame											
1	TWO	Two stop-bits are transmitted with every frame											

Bit	Name	Reset	Access	Description
3:2	PARITY	0x0	RW	Parity-Bit Mode Determines whether parity bits are enabled, and whether even or odd parity should be used.
	Value	Mode	Description	
	0	NONE	Parity bits are not used	
	2	EVEN	Even parity are used. Parity bits are automatically generated and checked by hardware.	
	3	ODD	Odd parity is used. Parity bits are automatically generated and checked by hardware.	
1	DATABITS	0	RW	Data-Bit Mode This register sets the number of data bits.
	Value	Mode	Description	
	0	EIGHT	Each frame contains 8 data bits	
	1	NINE	Each frame contains 9 data bits	
0	AUTOTRI	0	RW	Automatic Transmitter Tristate When set, LEUn_TX is tristated whenever the transmitter is inactive.
	Value	Description		
	0	LEUn_TX is held high when the transmitter is inactive. INV inverts the inactive state.		
	1	LEUn_TX is tristated when the transmitter is inactive		

18.5.2 LEUARTn_CMD - Command Register (Async Reg)

For more information about Asynchronous Registers please see Section 5.3 (p. 18) .

Offset	Bit Position																																	
0x004	31	30	29	28	27	26	25	24	23	22	21	20	19	18	17	16	15	14	13	12	11	10	9	8	7	6	5	4	3	2	1	0		
Reset																	0	0	0	0	0	0	0	0	0	0	0	0	0	0	0	0	0	0
Access																	W1	W1	W1	W1	W1	W1	W1	W1	W1	W1	W1	W1	W1	W1	W1	W1	W1	W1
Name																	CLEARRX	CLEARTX	RXBLOCKDIS	RXBLOCKEN	TXDIS	TXEN	RXDIS	RXEN										

Bit	Name	Reset	Access	Description
31:8	<i>Reserved</i>	<i>To ensure compatibility with future devices, always write bits to 0. More information in Section 2.1 (p. 3)</i>		
7	CLEARRX	0	W1	Clear RX Set to clear receive buffer and the RX shift register.
6	CLEARTX	0	W1	Clear TX Set to clear transmit buffer and the TX shift register.
5	RXBLOCKDIS	0	W1	Receiver Block Disable Set to clear RXBLOCK, resulting in all incoming frames being loaded into the receive buffer.
4	RXBLOCKEN	0	W1	Receiver Block Enable Set to set RXBLOCK, resulting in all incoming frames being discarded.
3	TXDIS	0	W1	Transmitter Disable Set to disable transmission.
2	TXEN	0	W1	Transmitter Enable Set to enable data transmission.
1	RXDIS	0	W1	Receiver Disable Set to disable data reception. If a frame is under reception when the receiver is disabled, the incoming frame is discarded.
0	RXEN	0	W1	Receiver Enable

Bit	Name	Reset	Access	Description
Set to activate data reception on LEUn_RX.				

18.5.3 LEUARTn_STATUS - Status Register

Offset	Bit Position																															
0x008	31	30	29	28	27	26	25	24	23	22	21	20	19	18	17	16	15	14	13	12	11	10	9	8	7	6	5	4	3	2	1	0
Reset																											0	1	0	0	0	0
Access																											R	R	R	R	R	R
Name																											RXDATAV	TXBL	TXC	RXBLOCK	TXENS	RXENS

Bit	Name	Reset	Access	Description
31:6	Reserved	To ensure compatibility with future devices, always write bits to 0. More information in Section 2.1 (p. 3)		
5	RXDATAV	0	R	RX Data Valid Set when data is available in the receive buffer. Cleared when the receive buffer is empty.
4	TXBL	1	R	TX Buffer Level Indicates the level of the transmit buffer. Set when the transmit buffer is empty, and cleared when it is full.
3	TXC	0	R	TX Complete Set when a transmission has completed and no more data is available in the transmit buffer. Cleared when a new transmission starts.
2	RXBLOCK	0	R	Block Incoming Data When set, the receiver discards incoming frames. An incoming frame will not be loaded into the receive buffer if this bit is set at the instant the frame has been completely received.
1	TXENS	0	R	Transmitter Enable Status Set when the transmitter is enabled.
0	RXENS	0	R	Receiver Enable Status Set when the receiver is enabled. The receiver must be enabled for start frames, signal frames, and multi-processor address bit detection.

18.5.4 LEUARTn_CLKDIV - Clock Control Register (Async Reg)

For more information about Asynchronous Registers please see Section 5.3 (p. 18) .

Offset	Bit Position																															
0x00C	31	30	29	28	27	26	25	24	23	22	21	20	19	18	17	16	15	14	13	12	11	10	9	8	7	6	5	4	3	2	1	0
Reset															0x000																	
Access															RW																	
Name															DIV																	

Bit	Name	Reset	Access	Description
31:15	Reserved	To ensure compatibility with future devices, always write bits to 0. More information in Section 2.1 (p. 3)		
14:3	DIV	0x000	RW	Fractional Clock Divider Specifies the fractional clock divider for the LEUART.
2:0	Reserved	To ensure compatibility with future devices, always write bits to 0. More information in Section 2.1 (p. 3)		

18.5.5 LEUARTn_STARTFRAME - Start Frame Register (Async Reg)

For more information about Asynchronous Registers please see Section 5.3 (p. 18) .

Offset	Bit Position																															
0x010	31	30	29	28	27	26	25	24	23	22	21	20	19	18	17	16	15	14	13	12	11	10	9	8	7	6	5	4	3	2	1	0
Reset																									0x000							
Access																									RW							
Name																									STARTFRAME							

Bit	Name	Reset	Access	Description
31:9	Reserved	To ensure compatibility with future devices, always write bits to 0. More information in Section 2.1 (p. 3)		
8:0	STARTFRAME	0x000	RW	Start Frame When a frame matching STARTFRAME is detected by the receiver, STARTF interrupt flag is set, and if SFUBRX is set, RXBLOCK is cleared. The start-frame is be loaded into the RX buffer.

18.5.6 LEUARTn_SIGFRAME - Signal Frame Register (Async Reg)

For more information about Asynchronous Registers please see Section 5.3 (p. 18) .

Offset	Bit Position																															
0x014	31	30	29	28	27	26	25	24	23	22	21	20	19	18	17	16	15	14	13	12	11	10	9	8	7	6	5	4	3	2	1	0
Reset																									0x000							
Access																									RW							
Name																									SIGFRAME							

Bit	Name	Reset	Access	Description
31:9	Reserved	To ensure compatibility with future devices, always write bits to 0. More information in Section 2.1 (p. 3)		
8:0	SIGFRAME	0x000	RW	Signal Frame When a frame matching SIGFRAME is detected by the receiver, SIGF interrupt flag is set.

18.5.7 LEUARTn_RXDATAx - Receive Buffer Data Extended Register

Offset	Bit Position																																	
0x018	31	30	29	28	27	26	25	24	23	22	21	20	19	18	17	16	15	14	13	12	11	10	9	8	7	6	5	4	3	2	1	0		
Reset															0	0															0x000			
Access															R	R															R			
Name															FERR	PERR															RXDATA			

Bit	Name	Reset	Access	Description
31:16	Reserved	To ensure compatibility with future devices, always write bits to 0. More information in Section 2.1 (p. 3)		
15	FERR	0	R	Receive Data Framing Error Set if data in buffer has a framing error. Can be the result of a break condition.
14	PERR	0	R	Receive Data Parity Error Set if data in buffer has a parity error.
13:9	Reserved	To ensure compatibility with future devices, always write bits to 0. More information in Section 2.1 (p. 3)		
8:0	RXDATA	0x000	R	RX Data Use this register to access data read from the LEUART. Buffer is cleared on read access.

18.5.8 LEUARTn_RXDATA - Receive Buffer Data Register

Offset	Bit Position																															
0x01C	31	30	29	28	27	26	25	24	23	22	21	20	19	18	17	16	15	14	13	12	11	10	9	8	7	6	5	4	3	2	1	0
Reset																									0x00							
Access																									R							
Name																									RXDATA							

Bit	Name	Reset	Access	Description
31:8	Reserved	To ensure compatibility with future devices, always write bits to 0. More information in Section 2.1 (p. 3)		
7:0	RXDATA	0x00	R	RX Data Use this register to access data read from LEUART. Buffer is cleared on read access. Only the 8 LSB can be read using this register.

18.5.9 LEUARTn_RXDATAXP - Receive Buffer Data Extended Peek Register

Offset	Bit Position																																	
0x020	31	30	29	28	27	26	25	24	23	22	21	20	19	18	17	16	15	14	13	12	11	10	9	8	7	6	5	4	3	2	1	0		
Reset															0	0															0x000			
Access															R	R															R			
Name															FERRP	PERRP															RXDATAP			

Bit	Name	Reset	Access	Description
31:16	Reserved	To ensure compatibility with future devices, always write bits to 0. More information in Section 2.1 (p. 3)		
15	FERRP	0	R	Receive Data Framing Error Peek Set if data in buffer has a framing error. Can be the result of a break condition.
14	PERRP	0	R	Receive Data Parity Error Peek Set if data in buffer has a parity error.

Bit	Name	Reset	Access	Description
13:9	Reserved	To ensure compatibility with future devices, always write bits to 0. More information in Section 2.1 (p. 3)		
8:0	RXDATAP	0x000	R	RX Data Peek Use this register to access data read from the LEUART.

18.5.10 LEUARTn_TXDATAx - Transmit Buffer Data Extended Register (Async Reg)

For more information about Asynchronous Registers please see Section 5.3 (p. 18) .

Offset	Bit Position																																		
	31	30	29	28	27	26	25	24	23	22	21	20	19	18	17	16	15	14	13	12	11	10	9	8	7	6	5	4	3	2	1	0			
0x024																0	0	0													0x000				
Reset																0	0	0													0x000				
Access																W	W	W													W				
Name																RXENAT	TXDISAT	TXBREAK													TXDATA				

Bit	Name	Reset	Access	Description
31:16	Reserved	To ensure compatibility with future devices, always write bits to 0. More information in Section 2.1 (p. 3)		
15	RXENAT	0	W	Enable RX After Transmission Set to enable reception after transmission.
	Value	Description		
	0	-		
	1	The receiver is enabled, setting RXENS after the frame has been transmitted		
14	TXDISAT	0	W	Disable TX After Transmission Set to disable transmitter directly after transmission has completed.
	Value	Description		
	0	-		
	1	The transmitter is disabled, clearing TXENS after the frame has been transmitted		
13	TXBREAK	0	W	Transmit Data As Break Set to send data as a break. Recipient will see a framing error or a break condition depending on its configuration and the value of TXDATA.
	Value	Description		
	0	The specified number of stop-bits are transmitted		
	1	Instead of the ordinary stop-bits, 0 is transmitted to generate a break. A single stop-bit is generated after the break to allow the receiver to detect the start of the next frame		
12:9	Reserved	To ensure compatibility with future devices, always write bits to 0. More information in Section 2.1 (p. 3)		
8:0	TXDATA	0x000	W	TX Data Use this register to write data to the LEUART. If the transmitter is enabled, a transfer will be initiated at the first opportunity.

18.5.11 LEUARTn_TXDATA - Transmit Buffer Data Register (Async Reg)

For more information about Asynchronous Registers please see Section 5.3 (p. 18) .

Offset	Bit Position																															
0x028	31	30	29	28	27	26	25	24	23	22	21	20	19	18	17	16	15	14	13	12	11	10	9	8	7	6	5	4	3	2	1	0
Reset																									0x00							
Access																									W							
Name																									TXDATA							

Bit	Name	Reset	Access	Description
31:8	Reserved	To ensure compatibility with future devices, always write bits to 0. More information in Section 2.1 (p. 3)		
7:0	TXDATA	0x00	W	TX Data This frame will be added to the transmit buffer. Only 8 LSB can be written using this register. 9th bit and control bits will be cleared.

18.5.12 LEUARTn_IF - Interrupt Flag Register

Offset	Bit Position																																																							
0x02C	31	30	29	28	27	26	25	24	23	22	21	20	19	18	17	16	15	14	13	12	11	10	9	8	7	6	5	4	3	2	1	0																								
Reset																									0	0	0	0	0	0	0	0	0	0	0	0	0	0	0	0	0	0	0	0	0	0	0	0	0	0	0	0	0	0	0	
Access																									R	R	R	R	R	R	R	R	R	R	R	R	R	R	R	R	R	R	R	R	R	R	R	R	R	R	R	R	R	R	R	R
Name																									SIGF	STARTF	MPAF	FERR	PERR	TXOF	RXUF	RXOF	RXDATAV	TXBL	TXC																					

Bit	Name	Reset	Access	Description
31:11	Reserved	To ensure compatibility with future devices, always write bits to 0. More information in Section 2.1 (p. 3)		
10	SIGF	0	R	Signal Frame Interrupt Flag Set when a signal frame is detected.
9	STARTF	0	R	Start Frame Interrupt Flag Set when a start frame is detected.
8	MPAF	0	R	Multi-Processor Address Frame Interrupt Flag Set when a multi-processor address frame is detected.
7	FERR	0	R	Framing Error Interrupt Flag Set when a frame with a framing error is received while RXBLOCK is cleared.
6	PERR	0	R	Parity Error Interrupt Flag Set when a frame with a parity error is received while RXBLOCK is cleared.
5	TXOF	0	R	TX Overflow Interrupt Flag Set when a write is done to the transmit buffer while it is full. The data already in the transmit buffer is preserved.
4	RXUF	0	R	RX Underflow Interrupt Flag Set when trying to read from the receive buffer when it is empty.
3	RXOF	0	R	RX Overflow Interrupt Flag Set when data is incoming while the receive shift register is full. The data previously in shift register is overwritten by the new data.
2	RXDATAV	0	R	RX Data Valid Interrupt Flag Set when data becomes available in the receive buffer.
1	TXBL	1	R	TX Buffer Level Interrupt Flag Set when space becomes available in the transmit buffer for a new frame.

Bit	Name	Reset	Access	Description
0	TXC	0	R	TX Complete Interrupt Flag Set after a transmission when both the TX buffer and shift register are empty.

18.5.13 LEUARTn_IFS - Interrupt Flag Set Register

Offset	Bit Position																																																			
0x030	31	30	29	28	27	26	25	24	23	22	21	20	19	18	17	16	15	14	13	12	11	10	9	8	7	6	5	4	3	2	1	0																				
Reset																						0	0	0	0	0	0	0	0	0	0	0	0	0	0	0	0	0	0	0	0	0	0	0	0	0	0	0	0	0	0	0
Access																						W1	W1	W1	W1	W1	W1	W1	W1	W1	W1	W1	W1	W1	W1	W1	W1	W1	W1	W1	W1	W1	W1	W1	W1	W1	W1	W1	W1	W1	W1	W1
Name																						SIGF	STARTF	MPAF	FERR	PERR	TXOF	RXUF	RXOF																							TXC

Bit	Name	Reset	Access	Description
31:11	<i>Reserved</i>	<i>To ensure compatibility with future devices, always write bits to 0. More information in Section 2.1 (p. 3)</i>		
10	SIGF	0	W1	Set Signal Frame Interrupt Flag Write to 1 to set the SIGF interrupt flag.
9	STARTF	0	W1	Set Start Frame Interrupt Flag Write to 1 to set the STARTF interrupt flag.
8	MPAF	0	W1	Set Multi-Processor Address Frame Interrupt Flag Write to 1 to set the MPAF interrupt flag.
7	FERR	0	W1	Set Framing Error Interrupt Flag Write to 1 to set the FERR interrupt flag.
6	PERR	0	W1	Set Parity Error Interrupt Flag Write to 1 to set the PERR interrupt flag.
5	TXOF	0	W1	Set TX Overflow Interrupt Flag Write to 1 to set the TXOF interrupt flag.
4	RXUF	0	W1	Set RX Underflow Interrupt Flag Write to 1 to set the RXUF interrupt flag.
3	RXOF	0	W1	Set RX Overflow Interrupt Flag Write to 1 to set the RXOF interrupt flag.
2:1	<i>Reserved</i>	<i>To ensure compatibility with future devices, always write bits to 0. More information in Section 2.1 (p. 3)</i>		
0	TXC	0	W1	Set TX Complete Interrupt Flag Write to 1 to set the TXC interrupt flag.

18.5.14 LEUARTn_IFC - Interrupt Flag Clear Register

Offset	Bit Position																																																			
0x034	31	30	29	28	27	26	25	24	23	22	21	20	19	18	17	16	15	14	13	12	11	10	9	8	7	6	5	4	3	2	1	0																				
Reset																						0	0	0	0	0	0	0	0	0	0	0	0	0	0	0	0	0	0	0	0	0	0	0	0	0	0	0	0	0	0	0
Access																						W1	W1	W1	W1	W1	W1	W1	W1	W1	W1	W1	W1	W1	W1	W1	W1	W1	W1	W1	W1	W1	W1	W1	W1	W1	W1	W1	W1	W1	W1	W1
Name																						SIGF	STARTF	MPAF	FERR	PERR	TXOF	RXUF	RXOF																							TXC

Bit	Name	Reset	Access	Description
31:11	Reserved	To ensure compatibility with future devices, always write bits to 0. More information in Section 2.1 (p. 3)		
10	SIGF	0	W1	Clear Signal-Frame Interrupt Flag Write to 1 to clear the SIGF interrupt flag.
9	STARTF	0	W1	Clear Start-Frame Interrupt Flag Write to 1 to clear the STARTF interrupt flag.
8	MPAF	0	W1	Clear Multi-Processor Address Frame Interrupt Flag Write to 1 to clear the MPAF interrupt flag.
7	FERR	0	W1	Clear Framing Error Interrupt Flag Write to 1 to clear the FERR interrupt flag.
6	PERR	0	W1	Clear Parity Error Interrupt Flag Write to 1 to clear the PERR interrupt flag.
5	TXOF	0	W1	Clear TX Overflow Interrupt Flag Write to 1 to clear the TXOF interrupt flag.
4	RXUF	0	W1	Clear RX Underflow Interrupt Flag Write to 1 to clear the RXUF interrupt flag.
3	RXOF	0	W1	Clear RX Overflow Interrupt Flag Write to 1 to clear the RXOF interrupt flag.
2:1	Reserved	To ensure compatibility with future devices, always write bits to 0. More information in Section 2.1 (p. 3)		
0	TXC	0	W1	Clear TX Complete Interrupt Flag Write to 1 to clear the TXC interrupt flag.

18.5.15 LEUARTn_IEN - Interrupt Enable Register

Offset	Bit Position																																
	31	30	29	28	27	26	25	24	23	22	21	20	19	18	17	16	15	14	13	12	11	10	9	8	7	6	5	4	3	2	1	0	
0x038																																	
Reset																							0	0	0	0	0	0	0	0	0	0	0
Access																							RW	RW	RW	RW	RW	RW	RW	RW	RW	RW	RW
Name																							SIGF	STARTF	MPAF	FERR	PERR	TXOF	RXUF	RXOF	RXDATAV	TXBL	TXC

Bit	Name	Reset	Access	Description
31:11	Reserved	To ensure compatibility with future devices, always write bits to 0. More information in Section 2.1 (p. 3)		
10	SIGF	0	RW	Signal Frame Interrupt Enable Enable interrupt on signal frame.
9	STARTF	0	RW	Start Frame Interrupt Enable Enable interrupt on start frame.
8	MPAF	0	RW	Multi-Processor Address Frame Interrupt Enable Enable interrupt on multi-processor address frame.
7	FERR	0	RW	Framing Error Interrupt Enable Enable interrupt on framing error.
6	PERR	0	RW	Parity Error Interrupt Enable Enable interrupt on parity error.
5	TXOF	0	RW	TX Overflow Interrupt Enable Enable interrupt on TX overflow.

Bit	Name	Reset	Access	Description
4	RXUF Enable interrupt on RX underflow.	0	RW	RX Underflow Interrupt Enable
3	RXOF Enable interrupt on RX overflow.	0	RW	RX Overflow Interrupt Enable
2	RXDATAV Enable interrupt on RX data.	0	RW	RX Data Valid Interrupt Enable
1	TXBL Enable interrupt on TX buffer level.	0	RW	TX Buffer Level Interrupt Enable
0	TXC Enable interrupt on TX complete.	0	RW	TX Complete Interrupt Enable

18.5.16 LEUARTn_PULSECTRL - Pulse Control Register (Async Reg)

For more information about Asynchronous Registers please see Section 5.3 (p. 18) .

Offset	Bit Position																															
0x03C	31	30	29	28	27	26	25	24	23	22	21	20	19	18	17	16	15	14	13	12	11	10	9	8	7	6	5	4	3	2	1	0
Reset																									0	0	0x0					
Access																									RW	RW	RW					
Name																									PULSEFILT	PULSEEN	PULSEW					

Bit	Name	Reset	Access	Description
31:6	<i>Reserved</i>	<i>To ensure compatibility with future devices, always write bits to 0. More information in Section 2.1 (p. 3)</i>		
5	PULSEFILT Enable a one-cycle pulse filter for pulse extender	0	RW	Pulse Filter
	Value	Description		
	0	Filter is disabled. Pulses must be at least 2 cycles long for reliable detection.		
	1	Filter is enabled. Pulses must be at least 3 cycles long for reliable detection.		
4	PULSEEN Filter LEUART output through pulse generator and the LEUART input through the pulse extender.	0	RW	Pulse Generator/Extender Enable
3:0	PULSEW Configure the pulse width of the pulse generator as a number of 32.768 kHz clock cycles.	0x0	RW	Pulse Width

18.5.17 LEUARTn_FREEZE - Freeze Register

Offset	Bit Position																															
0x040	31	30	29	28	27	26	25	24	23	22	21	20	19	18	17	16	15	14	13	12	11	10	9	8	7	6	5	4	3	2	1	0
Reset																																0
Access																																RW
Name																																REGFREEZE

Bit	Name	Reset	Access	Description
31:1	Reserved	To ensure compatibility with future devices, always write bits to 0. More information in Section 2.1 (p. 3)		
0	REGFREEZE	0	RW	Register Update Freeze When set, the update of the LEUART is postponed until this bit is cleared. Use this bit to update several registers simultaneously.
	Value	Mode	Description	
	0	UPDATE	Each write access to a LEUART register is updated into the Low Frequency domain as soon as possible.	
	1	FREEZE	The LEUART is not updated with the new written value.	

18.5.18 LEUARTn_SYNCBUSY - Synchronization Busy Register

Offset	Bit Position																																																					
	31	30	29	28	27	26	25	24	23	22	21	20	19	18	17	16	15	14	13	12	11	10	9	8	7	6	5	4	3	2	1	0																						
0x044																									R	0	R	0	R	0	R	0	R	0	R	0	R	0	R	0	R	0	R	0	R	0	R	0	R	0	R	0	R	0
Reset																									R	0	R	0	R	0	R	0	R	0	R	0	R	0	R	0	R	0	R	0	R	0	R	0	R	0	R	0	R	0
Access																									R	0	R	0	R	0	R	0	R	0	R	0	R	0	R	0	R	0	R	0	R	0	R	0	R	0	R	0	R	0
Name																									PULSECTRL	TXDATA	TXDATA	SIGFRAME	STARTFRAME	CLKDIV	CMD	CTRL																						

Bit	Name	Reset	Access	Description
31:8	Reserved	To ensure compatibility with future devices, always write bits to 0. More information in Section 2.1 (p. 3)		
7	PULSECTRL	0	R	LEUARTn_PULSECTRL Register Busy Set when the value written to LEUARTn_PULSECTRL is being synchronized.
6	TXDATA	0	R	LEUARTn_TXDATA Register Busy Set when the value written to LEUARTn_TXDATA is being synchronized.
5	TXDATA	0	R	LEUARTn_TXDATA Register Busy Set when the value written to LEUARTn_TXDATA is being synchronized.
4	SIGFRAME	0	R	LEUARTn_SIGFRAME Register Busy Set when the value written to LEUARTn_SIGFRAME is being synchronized.
3	STARTFRAME	0	R	LEUARTn_STARTFRAME Register Busy Set when the value written to LEUARTn_STARTFRAME is being synchronized.
2	CLKDIV	0	R	LEUARTn_CLKDIV Register Busy Set when the value written to LEUARTn_CLKDIV is being synchronized.
1	CMD	0	R	LEUARTn_CMD Register Busy Set when the value written to LEUARTn_CMD is being synchronized.
0	CTRL	0	R	LEUARTn_CTRL Register Busy Set when the value written to LEUARTn_CTRL is being synchronized.

18.5.19 LEUARTn_ROUTE - I/O Routing Register

Offset	Bit Position																															
0x054	31	30	29	28	27	26	25	24	23	22	21	20	19	18	17	16	15	14	13	12	11	10	9	8	7	6	5	4	3	2	1	0
Reset																							0x0						0	0		
Access																							RW						RW	RW		
Name																							LOCATION						TXPEN	RXPEN		

Bit	Name	Reset	Access	Description
31:10	<i>Reserved</i>	<i>To ensure compatibility with future devices, always write bits to 0. More information in Section 2.1 (p. 3)</i>		

9:8	LOCATION	0x0	RW	I/O Location
Decides the location of the LEUART I/O pins.				
	Value	Mode	Description	
	0	LOC0	Location 0	
	1	LOC1	Location 1	
	2	LOC2	Location 2	
	3	LOC3	Location 3	

7:2	<i>Reserved</i>	<i>To ensure compatibility with future devices, always write bits to 0. More information in Section 2.1 (p. 3)</i>		
-----	-----------------	--	--	--

1	TXPEN	0	RW	TX Pin Enable
When set, the TX pin of the LEUART is enabled.				
	Value	Description		
	0	The LEUn_TX pin is disabled		
	1	The LEUn_TX pin is enabled		

0	RXPEN	0	RW	RX Pin Enable
When set, the RX pin of the LEUART is enabled.				
	Value	Description		
	0	The LEUn_RX pin is disabled		
	1	The LEUn_RX pin is enabled		

19 TIMER - Timer/Counter

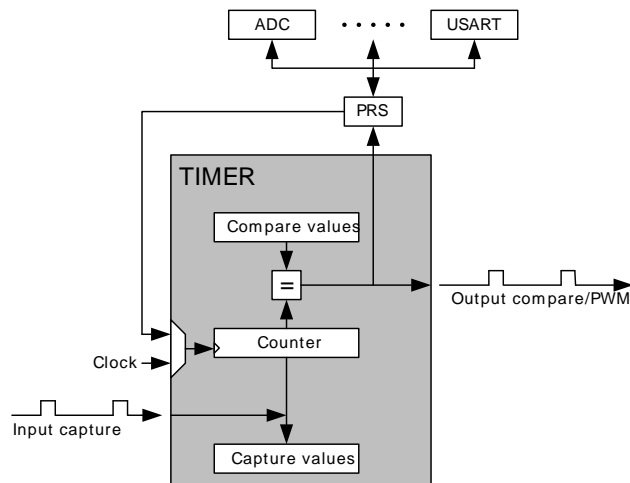
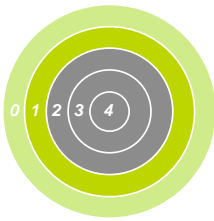

Quick Facts

What?

The TIMER (Timer/Counter) keeps track of timing and counts events, generates output waveforms and triggers timed actions in other peripherals.

Why?

Most applications have activities that need to be timed accurately with as little CPU intervention and energy consumption as possible.

How?

The flexible 16-bit TIMER can be configured to provide PWM waveforms with optional dead-time insertion for e.g. motor control, or work as a frequency generator. The Timer can also count events and control other peripherals through the PRS, which offloads the CPU and reduce energy consumption.

19.1 Introduction

The 16-bit general purpose Timer has 3 compare/capture channels for input capture and compare/Pulse-Width Modulation (PWM) output. TIMER0 also includes a Dead-Time Insertion module suitable for motor control applications.

19.2 Features

- 16-bit auto reload up/down counter
 - Dedicated 16-bit reload register which serves as counter maximum
- 3 Compare/Capture channels
 - Individual configurable as either input capture or output compare/PWM
- Multiple Counter modes
 - Count up
 - Count down
 - Count up/down
 - Quadrature Decoder
 - Direction and count from external pins
- Counter control from PRS or external pin
 - Start
 - Stop
 - Reload and start
- Inter-Timer connection
 - Allows 32-bit counter mode
 - Start/stop synchronization between several Timers
- Input Capture
 - Period measurement

- Pulse width measurement
- Two capture registers for each capture channel
 - Capture on either positive or negative edge
 - Capture on both edges
- Optional digital noise filtering on capture inputs
- Output Compare
 - Compare output toggle/pulse on compare match
 - Immediate update of compare registers
- PWM
 - Up-count PWM
 - Up/down-count PWM
 - Predictable initial PWM output state (configured by SW)
 - Buffered compare register to ensure glitch-free update of compare values
- Clock sources
 - HFPERCLK_{TIMERn}
 - 10-bit Prescaler
 - External pin
 - Peripheral Reflex System
- Debug mode
 - Configurable to either run or stop when processor is stopped (break)
- Interrupts, PRS output and/or DMA request
 - Underflow
 - Overflow
 - Compare/Capture event
- Dead-Time Insertion Unit (TIMER0 only)
 - Complementary PWM outputs with programmable dead-time
 - Dead-time is specified independently for rising and falling edge
 - 10-bit prescaler
 - 6-bit time value
 - Outputs have configurable polarity
 - Outputs can be set inactive individually by software.
 - Configurable action on fault
 - Set outputs inactive
 - Clear output
 - Tristate output
 - Individual fault sources
 - One or two PRS signals
 - Debugger
 - Support for automatic restart
 - Core lockup
 - Configuration lock

19.3 Functional Description

An overview of the TIMER module is shown in Figure 19.1 (p. 246) . The Timer module consists of a 16 bit up/down counter with 3 Compare/Capture channels connected to pins TIMn_CC0, TIMn_CC1, and TIMn_CC2.

Figure 19.1. TIMER Block Overview

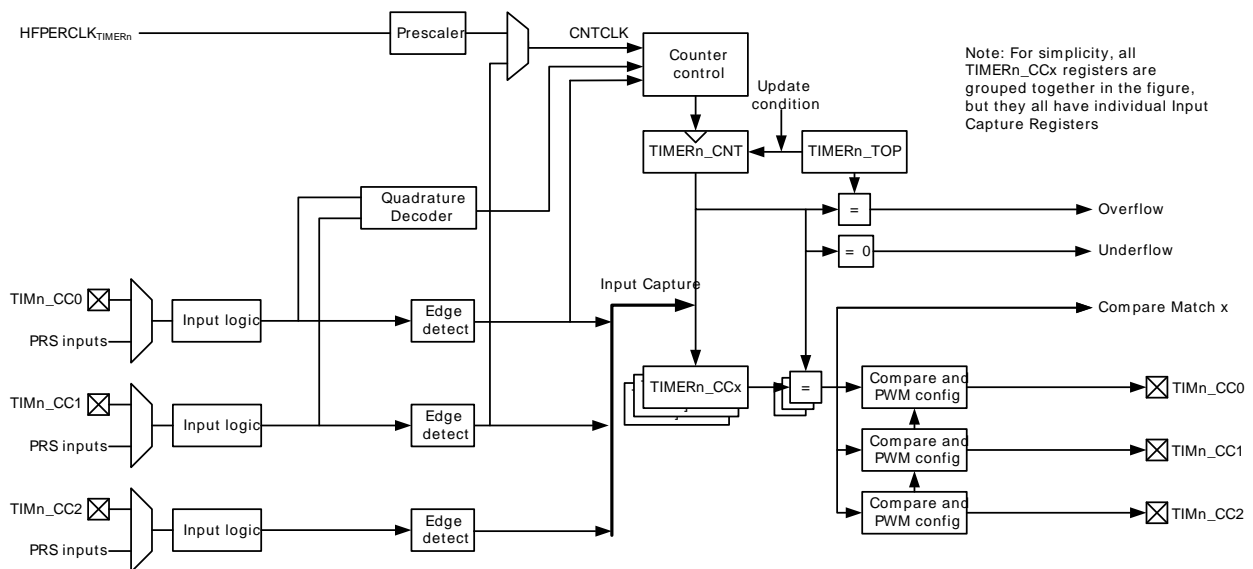

19.3.1 Counter Modes

The Timer consists of a counter that can be configured to the following modes:

1. Up-count: Counter counts up until it reaches the value in TIMERN_TOP, where it is reset to 0 before counting up again.
2. Down-count: The counter starts at the value in TIMERN_TOP and counts down. When it reaches 0, it is reloaded with the value in TIMERN_TOP.
3. Up/Down-count: The counter starts at 0 and counts up. When it reaches the value in TIMERN_TOP, it counts down until it reaches 0 and starts counting up again.
4. Quadrature Decoder: Two input channels where one determines the count direction, while the other pin triggers a clock event.

The counter value can be read or written by software at any time by accessing the CNT field in TIMERN_CNT.

19.3.1.1 Events

Overflow is set when the counter value shifts from TIMERN_TOP to the next value when counting up. In up-count mode the next value is 0. In up/down-count mode, the next value is TIMERN_TOP-1.

Underflow is set when the counter value shifts from 0 to the next value when counting down. In down-count mode, the next value is TIMERN_TOP. In up/down-count mode the next value is 1.

Update event is set on overflow in up-count mode and on underflow in down-count or up/down count mode. This event is used to time updates of buffered values.

19.3.1.2 Operation

Figure 19.2 (p. 247) shows the hardware Timer/Counter control. Software can start or stop the counter by writing a 1 to the START or STOP bits in TIMERN_CMD. The counter value (CNT in TIMERN_CNT) can always be written by software to any 16-bit value.

It is also possible to control the counter through either an external pin or PRS input. This is done through the input logic for the Compare/Capture Channel 0. The Timer/Counter allows individual actions (start, stop, reload) to be taken for rising and falling input edges. This is configured in the RISEA and FALLA

fields in TIMERN_CTRL. The reload value is 0 in up-count and up/down-count mode and TOP in down-count mode.

The RUNNING bit in TIMERN_STATUS indicates if the Timer is running or not. If the SYNC bit in TIMERN_CTRL is set, the Timer is started/stopped/reloaded (external pin or PRS) when any of the other timers are started/stopped/reloaded.

The DIR bit in TIMERN_STATUS indicates the counting direction of the Timer at any given time. The counter value can be read or written by software through the CNT field in TIMERN_CNT. In Up/Down-Count mode the count direction will be set to up if the CNT value is written by software.

Figure 19.2. TIMER Hardware Timer/Counter Control

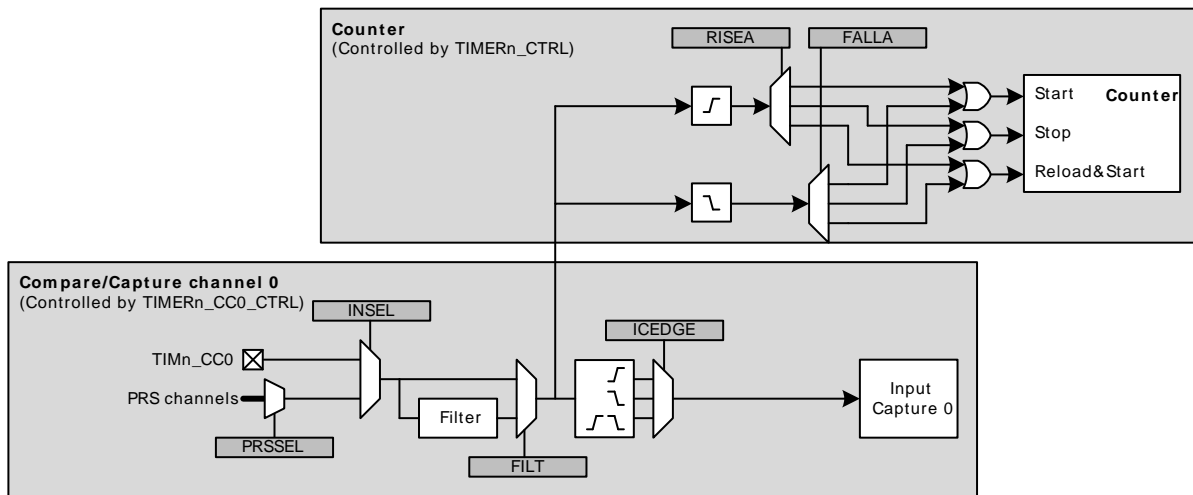

19.3.1.3 Clock Source

The counter can be clocked from several sources, which are all synchronized with the peripheral clock (HFPERCLK). See Figure 19.3 (p. 247) .

Figure 19.3. TIMER Clock Selection

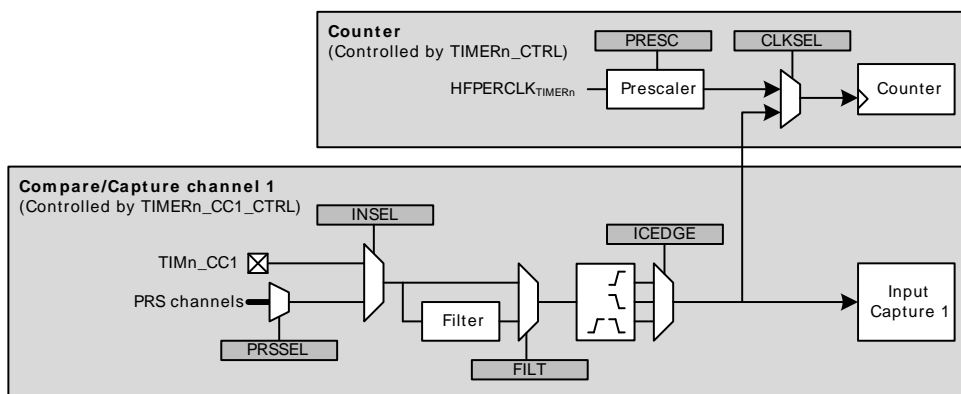

19.3.1.3.1 Peripheral Clock (HFPERCLK)

The peripheral clock (HFPERCLK) can be used as a source with a configurable prescale factor of 2^{PRESC} , where PRESC is an integer between 0 and 10, which is set in PRESC in TIMERN_CTRL. The prescaler is stopped and reset when the timer is stopped.

19.3.1.3.2 Compare/ Capture Channel 1 Input

The Timer can also be clocked by positive and/or negative edges on the Compare/Capture channel 1 input. This input can either come from the TIMn_CC1 pin or one of the PRS channels. The input signal

must not have a higher frequency than $f_{\text{HFPERCLK}}/3$ when running from a pin input or a PRS input with `FILT` enabled in `TIMERn_CCx_CTRL`. When running from PRS without `FILT`, the frequency can be as high as f_{HFPERCLK} . Note that when clocking the Timer from the same pulse that triggers a start (through `RISEA/FALLA` in `TIMERn_CTRL`), the starting pulse will not update the Counter Value.

19.3.1.3.3 Underflow/Overflow from Neighboring Timer

All Timers are linked together (see Figure 19.4 (p. 248)), allowing timers to count on overflow/underflow from the lower numbered neighbouring timers to form a 32-bit or 48-bit timer. Note that all timers must be set to same count direction and less significant timer(s) can only be set to count up or down.

Figure 19.4. TIMER Connections

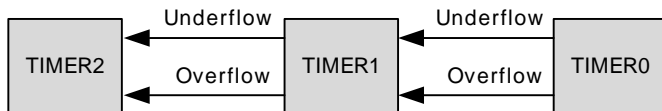

19.3.1.4 One-Shot Mode

By default, the counter counts continuously until it is stopped. If the `OSMEN` bit is set in the `TIMERn_CTRL` register, however, the counter is disabled by hardware on the first *update event*. Note that when the counter is running with `CC1` as clock source (0b01 in `CLKSEL` in `TIMERn_CTRL`) and `OSMEN` is set, a `CC1` capture event will not take place on the *update event* (`CC1` rising edge) that stops the Timer.

19.3.1.5 Top Value Buffer

The `TIMERn_TOP` register can be altered either by writing it directly or by writing to the `TIMER_TOPB` (buffer) register. When writing to the buffer register the `TIMERn_TOPB` register will be written to `TIMERn_TOP` on the next update event. Buffering ensures that the `TOP` value is not set below the actual count value. The `TOPBV` flag in `TIMERn_STATUS` indicates whether the `TIMERn_TOPB` register contains data that have not yet been written to the `TIMERn_TOP` register (see Figure 19.5 (p. 248)).

Figure 19.5. TIMER TOP Value Update Functionality

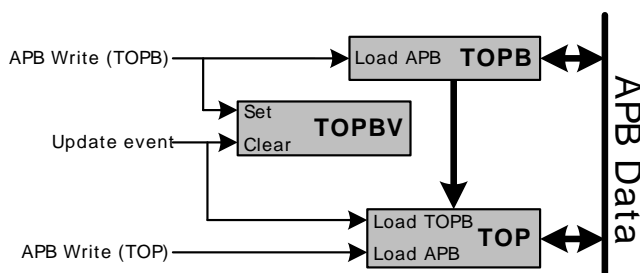

19.3.1.6 Quadrature Decoder

Quadrature Decoding mode is used to track motion and determine both rotation direction and position. The Quadrature Decoder uses two input channels that are 90 degrees out of phase (see Figure 19.6 (p. 249)).

Figure 19.6. TIMER Quadrature Encoded Inputs

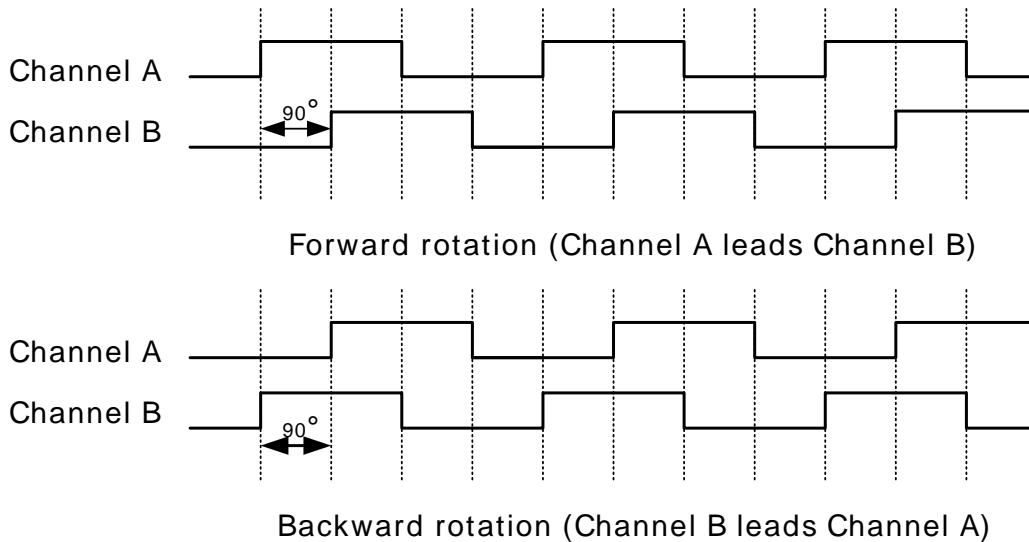

In the Timer these inputs are tapped from the Compare/Capture channel 0 (Channel A) and 1 (Channel B) inputs before edge detection. The Timer/Counter then increments or decrements the counter, based on the phase relation between the two inputs. The Quadrature Decoder Mode supports two channels, but if a third channel (Z-terminal) is available, this can be connected to an external interrupt and trigger a counter reset from the interrupt service routine. By connecting a periodic signal from another timer as input capture on Compare/Capture Channel 2, it is also possible to calculate speed and acceleration.

Figure 19.7. TIMER Quadrature Decoder Configuration

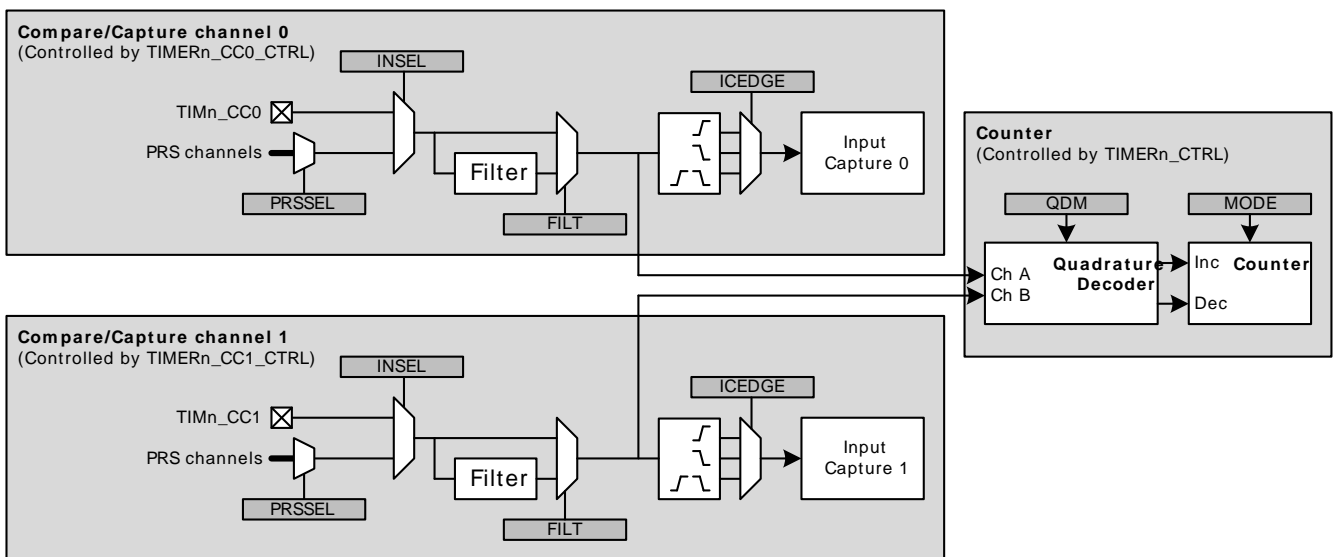

The Quadrature Decoder can be set in either X2 or X4 mode, which is configured in the QDM bit in TIMERN_CTRL. See Figure 19.7 (p. 249)

19.3.1.6.1 X2 Decoding Mode

In X2 Decoding mode, the counter increments or decrements on every edge of Channel A, see Table 19.1 (p. 250) and Figure 19.8 (p. 250) .

Table 19.1. TIMER Counter Response in X2 Decoding Mode

Channel B	Channel A	
	Rising	Falling
0	Increment	Decrement
1	Decrement	Increment

Figure 19.8. TIMER X2 Decoding Mode

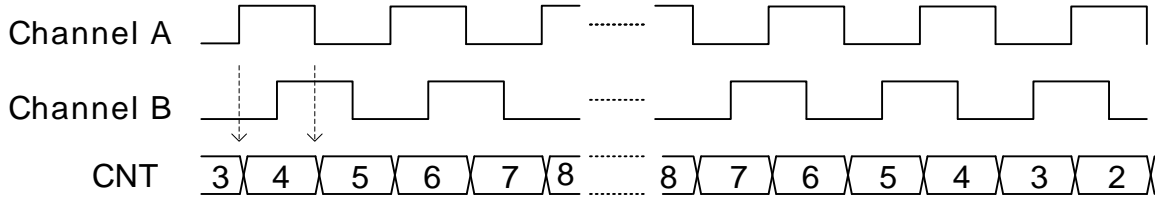

19.3.1.6.2 X4 Decoding Mode

In X4 Decoding mode, the counter increments or decrements on every edge of Channel A and Channel B, see Figure 19.9 (p. 250) and Table 19.2 (p. 250) .

Table 19.2. TIMER Counter Response in X4 Decoding Mode

Opposite Channel	Channel A		Channel B	
	Rising	Falling	Rising	Falling
Channel A = 0			Decrement	Increment
Channel A = 1			Increment	Decrement
Channel B = 0	Increment	Decrement		
Channel B = 1	Decrement	Increment		

Figure 19.9. TIMER X4 Decoding Mode

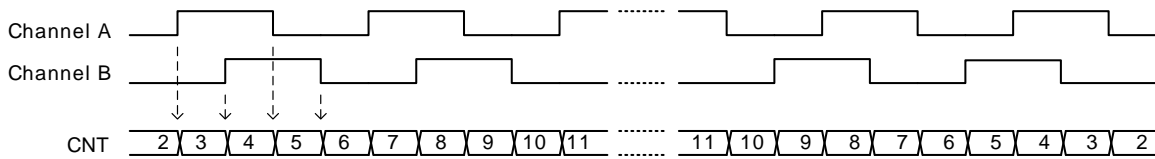

19.3.1.6.3 TIMER Rotational Position

To calculate a position Equation 19.1 (p. 250) can be used.

TIMER Rotational Position Equation

$$pos^\circ = (CNT/X \times N) \times 360^\circ \tag{19.1}$$

where X = Encoding type and N = Number of pulses per revolution.

19.3.2 Compare/Capture Channels

The Timer contains 3 Compare/Capture channels, which can be configured in the following modes:

1. Input Capture

- 2. Output Compare
- 3. PWM

19.3.2.1 Input Pin Logic

Each Compare/Capture channel can be configured as an input source for the Capture Unit or as external clock source for the Timer (see Figure 19.10 (p. 251)). Compare/Capture channels 0 and 1 are the inputs for the Quadrature Decoder Mode. The input channel can be filtered before it is used, which requires the input to remain stable for 5 cycles in a row before the input is propagated to the output.

Figure 19.10. TIMER Input Pin Logic

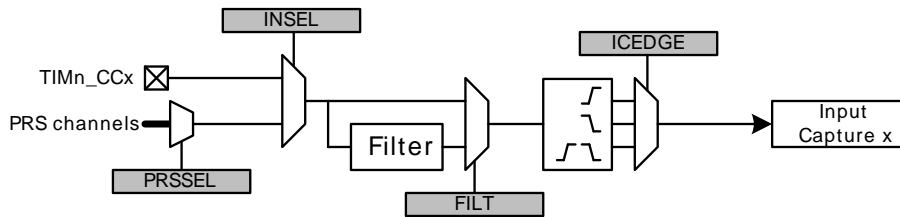

19.3.2.2 Compare/Capture Registers

The Compare/Capture channel registers are prefixed with `TIMERN_CCx_`, where the `x` stands for the channel number. Since the Compare/Capture channels serve three functions (input capture, compare, PWM), the behavior of the Compare/Capture registers (`TIMERN_CCx_CCv`) and buffer registers (`TIMERN_CCx_CCvB`) change depending on the mode the channel is set in.

19.3.2.2.1 Input Capture mode

When running in Input Capture mode, `TIMERN_CCx_CCv` and `TIMERN_CCx_CCvB` form a FIFO buffer, and new capture values are added on a capture event, see Figure 19.11 (p. 251) . The first capture can always be read from `TIMERN_CCx_CCv`, and reading this address will load the next capture value into `TIMERN_CCx_CCv` from `TIMERN_CCx_CCvB` if it contains valid data. The CC value can be read without altering the FIFO contents by reading `TIMERN_CCx_CCvP`. `TIMERN_CCx_CCvB` can also be read without altering the FIFO contents. The ICV flag in `TIMERN_STATUS` indicates if there is a valid unread capture in `TIMERN_CCx_CCv`.

In case a capture is triggered while both `CCv` and `CCvB` contain unread capture values, the buffer overflow interrupt flag (`ICBOF` in `TIMERN_IF`) will be set. New capture values will on overflow overwrite the value in `TIMERN_CCx_CCvB`.

Figure 19.11. TIMER Input Capture Buffer Functionality

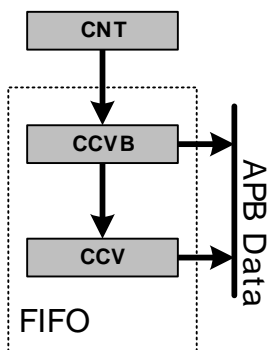

19.3.2.2.2 Compare and PWM Mode

When running in Output Compare or PWM mode, the value in `TIMERN_CCx_CCv` will be compared against the count value. In Compare mode the output can be configured to toggle, clear or set

on compare match, overflow and underflow through the CMOA, COFOA and CUFOA fields in `TIMERn_CCx_CTRL`. `TIMERn_CCx_CCv` can be accessed directly or through the buffer register `TIMERn_CCx_CCvB`, see Figure 19.12 (p. 252) . When writing to the buffer register, the value in `TIMERn_CCx_CCvB` will be written to `TIMERn_CCx_CCv` on the next update event. This functionality ensures glitch free PWM outputs. The `CCVBV` flag in `TIMERn_STATUS` indicates whether the `TIMERn_CCx_CCvB` register contains data that have not yet been written to the `TIMERn_CCx_CCv` register. Note that when writing 0 to `TIMERn_CCx_CCvB` the `CCv` value is updated when the timer counts from 0 to 1. Thus, the compare match for the next period will not happen until the timer reaches 0 again on the way down.

Figure 19.12. TIMER Output Compare/PWM Buffer Functionality

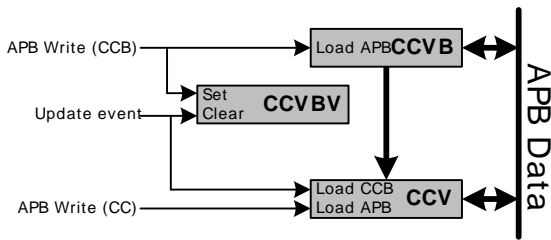

19.3.2.3 Input Capture

In Input Capture Mode, the counter value (`TIMERn_CNT`) can be captured in the Compare/Capture Register (`TIMERn_CCx_CCv`), see Figure 19.13 (p. 252) . In this mode, `TIMERn_CCx_CCv` is read-only. Together with the Compare/Capture Buffer Register (`TIMERn_CCx_CCvB`) the `TIMERn_CCx_CCv` form a double-buffered capture registers allowing two subsequent capture events to take place before a read-out is required. The `CCPOL` bits in `TIMERn_STATUS` indicate the polarity the edge that triggered the capture in `TIMERn_CCx_CCv`.

Figure 19.13. TIMER Input Capture

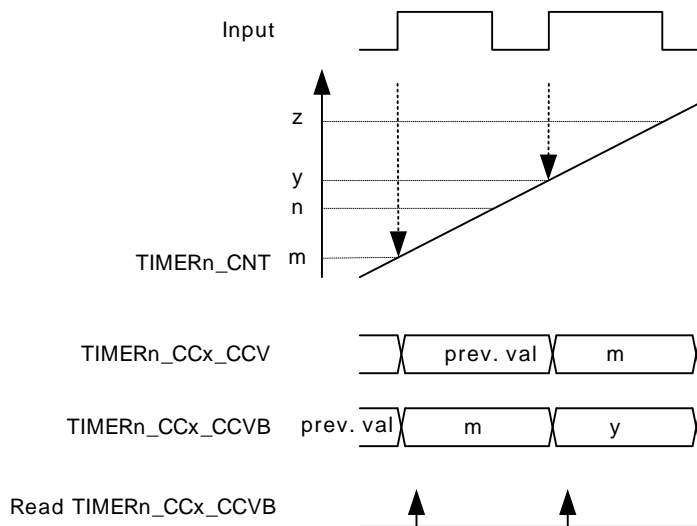

19.3.2.3.1 Period/Pulse-Width Capture

Period and/or pulse-width capture can be achieved by setting the `RISEA` field in `TIMERn_CTRL` to `Clear&Start`, and select the wanted input from either external pin or `PRS`, see Figure 19.14 (p. 253) . For period capture, the Compare/Capture Channel should then be set to input capture on a rising edge of the same input signal. To capture a the width of a high pulse, the Compare/Capture Channel should be set to capture on a falling edge of the input signal. To start the measuring period on either a falling edge or measure the low pulse-width of a signal, opposite polarities should be chosen.

Figure 19.14. TIMER Period and/or Pulse width Capture

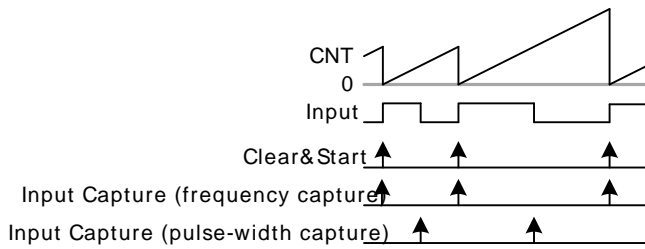

19.3.2.4 Compare

Each Compare/Capture channel contains a comparator which outputs a compare match if the contents of TIMERN_CCx_CCv matches the counter value, see Figure 19.15 (p. 253). In compare mode, each compare channel can be configured to either set, clear or toggle the output on an event (compare match, overflow or underflow). The output from each channel is represented as an alternative function on the port it is connected to, which needs to be enabled for the CC outputs to propagate to the pins.

Figure 19.15. TIMER Block Diagram Showing Comparison Functionality

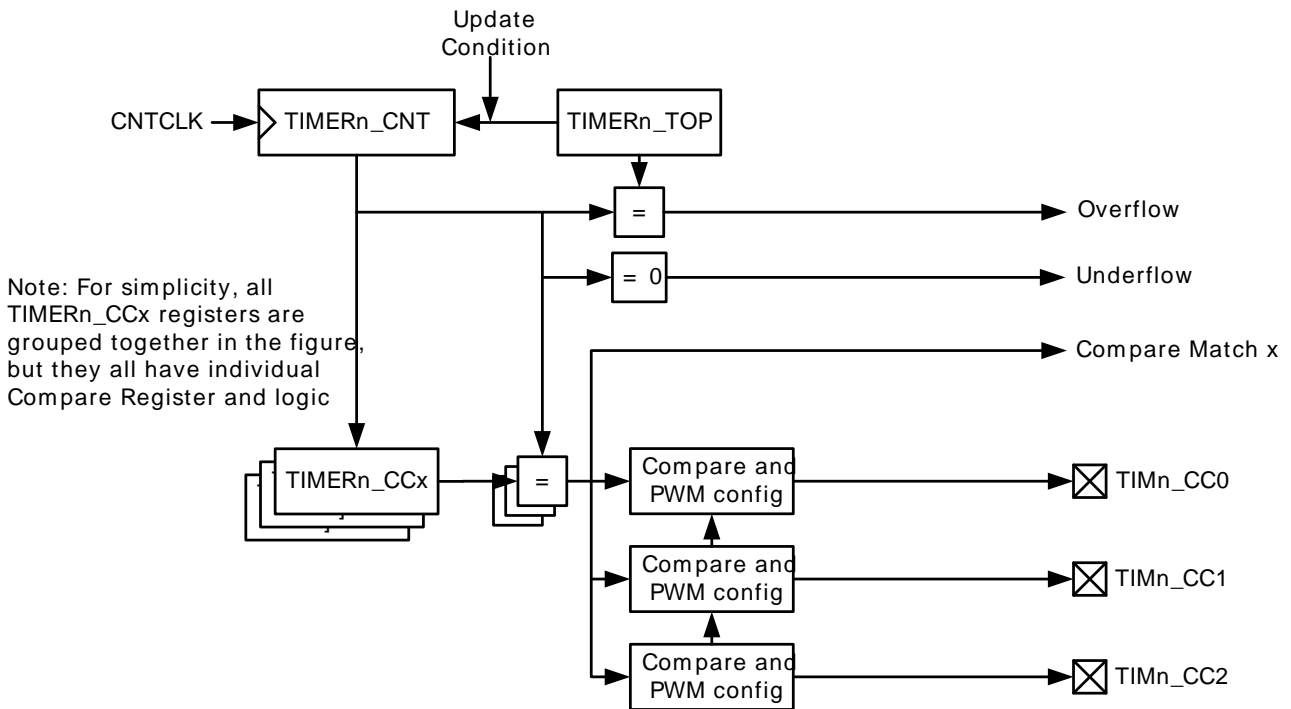

If occurring in the same cycle, match action will have priority over overflow or underflow action.

The input selected (through PRSSEL, INSEL and FILTSEL in TIMERN_CCx_CTRL) for the CC channel will also be sampled on compare match and the result is found in the CCPOL bits in TIMERN_STATUS.

The COIST bit in TIMERN_CCx_CTRL is the initial state of the compare/PWM output. Also the resulting output can be inverted by setting OUTINV in TIMERN_CCx_CTRL. It is recommended to turn off the CC channel before configuring the output state to avoid any pulses on the output. The CC channel can be turned off by setting MODE to OFF in TIMER_CCx_CTRL.

Figure 19.16. TIMER Output Logic

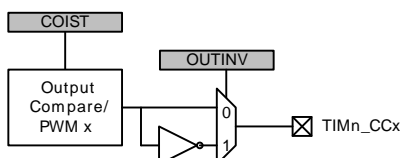

19.3.2.4.1 Frequency Generation (FRG)

Frequency generation (see Figure 19.17 (p. 254)) can be achieved in compare mode by:

- Setting the counter in up-count mode
- Enabling buffering of the TOP value.
- Setting the CC channels overflow action to toggle

Figure 19.17. TIMER Up-count Frequency Generation

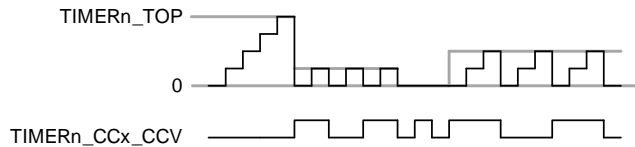

The output frequency is given by Equation 19.2 (p. 254)

TIMER Up-count Frequency Generation Equation

$$f_{FRG} = f_{HFPERCLK} / (2^{(PRESC + 1)} \times (TOP + 1)) \tag{19.2}$$

19.3.2.5 Pulse-Width Modulation (PWM)

In PWM mode, TIMERn_CCx_CCV is buffered to avoid glitches in the output. The settings in the Compare Output Action configuration bits are ignored in PWM mode and PWM generation is only supported for up-count and up/down-count mode.

19.3.2.6 Up-count (Single-slope) PWM

If the counter is set to up-count and the Compare/Capture channel is put in PWM mode, single slope PWM output will be generated (see Figure 19.18 (p. 254)). In up-count mode the PWM period is TOP +1 cycles and the PWM output will be high for a number of cycles equal to TIMERn_CCx_CCV. This means that a constant high output is achieved by setting TIMERn_CCx to TOP+1 or higher. The PWM resolution (in bits) is then given by Equation 19.3 (p. 254) .

Figure 19.18. TIMER Up-count PWM Generation

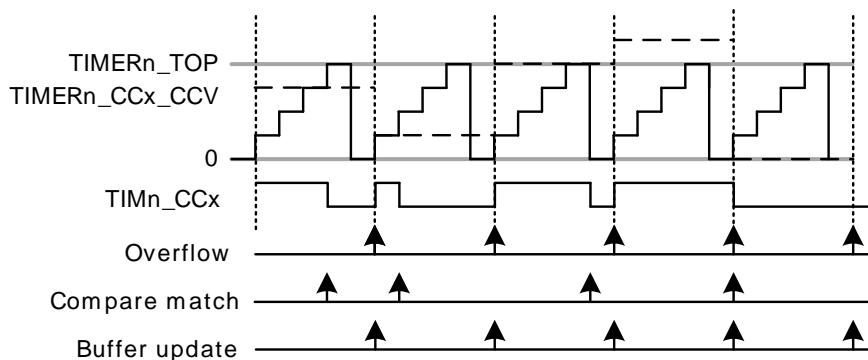

TIMER Up-count PWM Resolution Equation

$$R_{PWM_{up}} = \log(TOP+1)/\log(2) \tag{19.3}$$

The PWM frequency is given by Equation 19.4 (p. 254) :

TIMER Up-count PWM Frequency Equation

$$f_{PWM_{up/down}} = f_{HFPERCLK} / (2^{PRESC} \times (TOP + 1)) \tag{19.4}$$

The high duty cycle is given by Equation 19.5 (p. 255)

TIMER Up-count Duty Cycle Equation

$$DS_{up} = CCVx/TOP \tag{19.5}$$

19.3.2.7 Up/Down-count (Dual-slope) PWM

If the counter is set to up-down count and the Compare/Capture channel is put in PWM mode, dual slope PWM output will be generated by Figure 19.19 (p. 255) .The resolution (in bits) is given by Equation 19.6 (p. 255) .

Figure 19.19. TIMER Up/Down-count PWM Generation

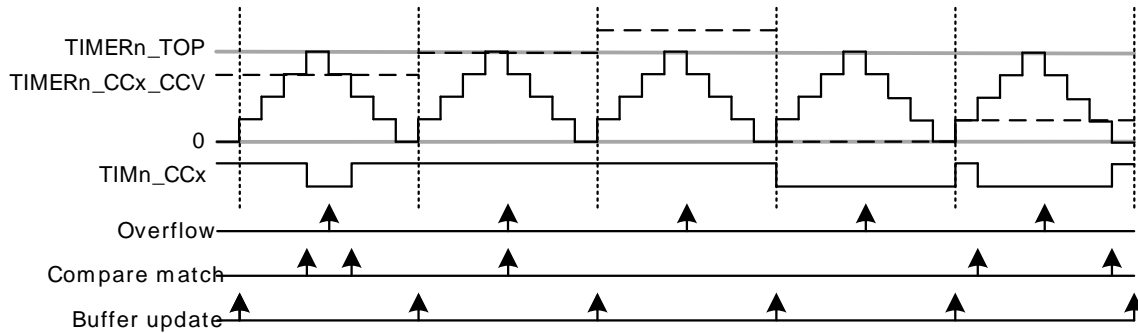

TIMER Up/Down-count PWM Resolution Equation

$$R_{PWM_{up/down}} = \log(TOP+1)/\log(2) \tag{19.6}$$

The PWM frequency is given by Equation 19.7 (p. 255) :

TIMER Up/Down-count PWM Frequency Equation

$$f_{PWM_{up/down}} = f_{HPPERCLK} / (2^{(PRESC+1)} \times TOP) \tag{19.7}$$

The high duty cycle is given by Equation 19.8 (p. 255)

TIMER Up/Down-count Duty Cycle Equation

$$DS_{up/down} = CCVx/TOP \tag{19.8}$$

19.3.3 Dead-Time Insertion Unit (TIMER0 only)

The Dead-Time Insertion Unit aims to make control of BLDC motors safer and more efficient by introducing complementary PWM outputs with dead-time insertion and fault handling, see Figure 19.20 (p. 255) .

Figure 19.20. TIMER Dead-Time Insertion Unit Overview

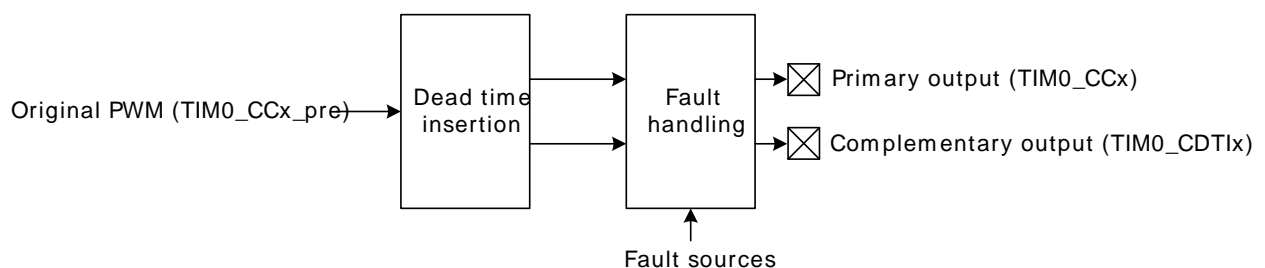

When used for motor control, the PWM outputs TIM0_CC0, TIM0_CC1 and TIM0_CC2 are often connected to the high-side transistors of a triple half-bridge setup (UH, VH and WH), and the

complementary outputs connected to the respective low-side transistors (UL, VL, WL shown in Figure 19.21 (p. 256)). Transistors used in such a bridge often do not open/close instantaneously, and using the exact complementary inputs for the high and low side of a half-bridge may result in situations where both gates are open. This can give unnecessary current-draw and short circuit the power supply. The DTI unit provides dead-time insertion to deal with this problem.

Figure 19.21. TIMER Triple Half-Bridge

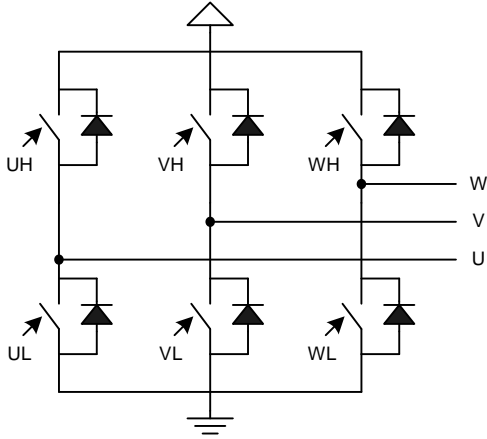

For each of the 3 compare-match outputs of TIMER0, an additional complementary output is provided by the DTI unit. These outputs, named TIM0_CDTI0, TIM0_CDTI1 and TIM0_CDTI2 are provided to make control of e.g. 3-channel BLDC or PMAC motors possible using only a single timer, see Figure 19.22 (p. 256) .

Figure 19.22. TIMER Overview of Dead-Time Insertion Block for a Single PWM channel

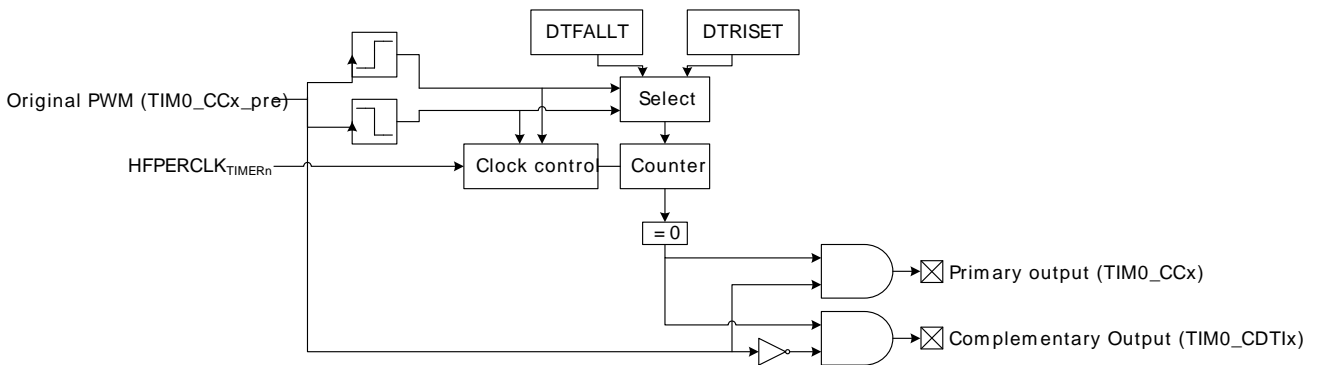

The DTI unit is enabled by setting DTEN in TIMER0_DTCTRL. In addition to providing the complementary outputs, the DTI unit then also overrides the compare match outputs from the timer.

The DTI unit gives the rising edges of the PWM outputs and the rising edges of the complementary PWM outputs a configurable time delay. By doing this, the DTI unit introduces a dead-time where both the primary and complementary outputs in a pair are inactive as seen in Figure 19.23 (p. 256) .

Figure 19.23. TIMER Polarity of Both Signals are Set as Active-High

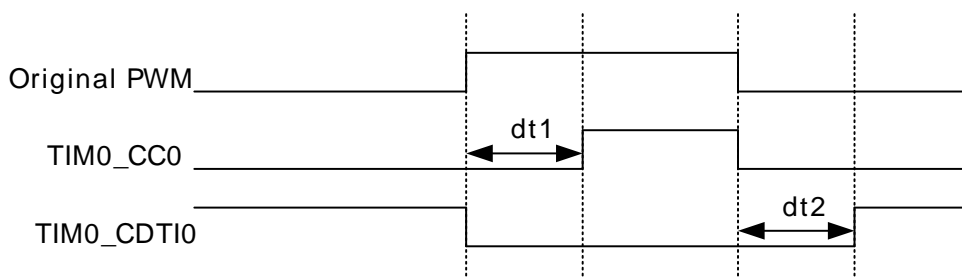

Dead-time is specified individually for the rising and falling edge of the original PWM. These values are shared across all the three PWM channels of the DTI unit. A single prescaler value is provided for the DTI unit, meaning that both the rising and falling edge dead-times share prescaler value. The prescaler divides the $HFPERCLK_{TIMERn}$ by a configurable factor between 1 and 1024, which is set in the DTPRESC field in `TIMER0_DDTIME`. The rising and falling edge dead-times are configured in `DTRISSET` and `DTFALLT` in `TIMER0_DDTIME` to any number between 1-64 $HFPERCLK_{TIMER0}$ cycles.

19.3.3.1 Output Polarity

The value of the primary and complementary outputs in a pair will never be set active at the same time by the DTI unit. The polarity of the outputs can be changed however, if this is required by the application. The active values of the primary and complementary outputs are set by two the `TIMER0_DTCTRL` register. The `DTIPOL` bit of this register specifies the base polarity. If `DTIPOL = 0`, then the outputs are active-high, and if `DTIPOL = 1` they are active-low. The relative phase of the primary and complementary outputs is not changed by `DTIPOL`, as the polarity of both outputs is changed, see Figure 19.24 (p. 257)

In some applications, it may be required that the primary outputs are active-high, while the complementary outputs are active-low. This can be accomplished by manipulating the `DTCINV` bit of the `TIMER0_DTCTRL` register, which inverts the polarity of the complementary outputs relative to the primary outputs.

Example 19.1. TIMER DTI Example 1

`DTIPOL = 0` and `DTCINV = 0` results in outputs with opposite phase and active-high states.

Example 19.2. TIMER DTI Example 2

`DTIPOL = 1` and `DTCINV = 1` results in outputs with equal phase. The primary output will be active-high, while the complementary will be active-low

Figure 19.24. TIMER Output Polarities

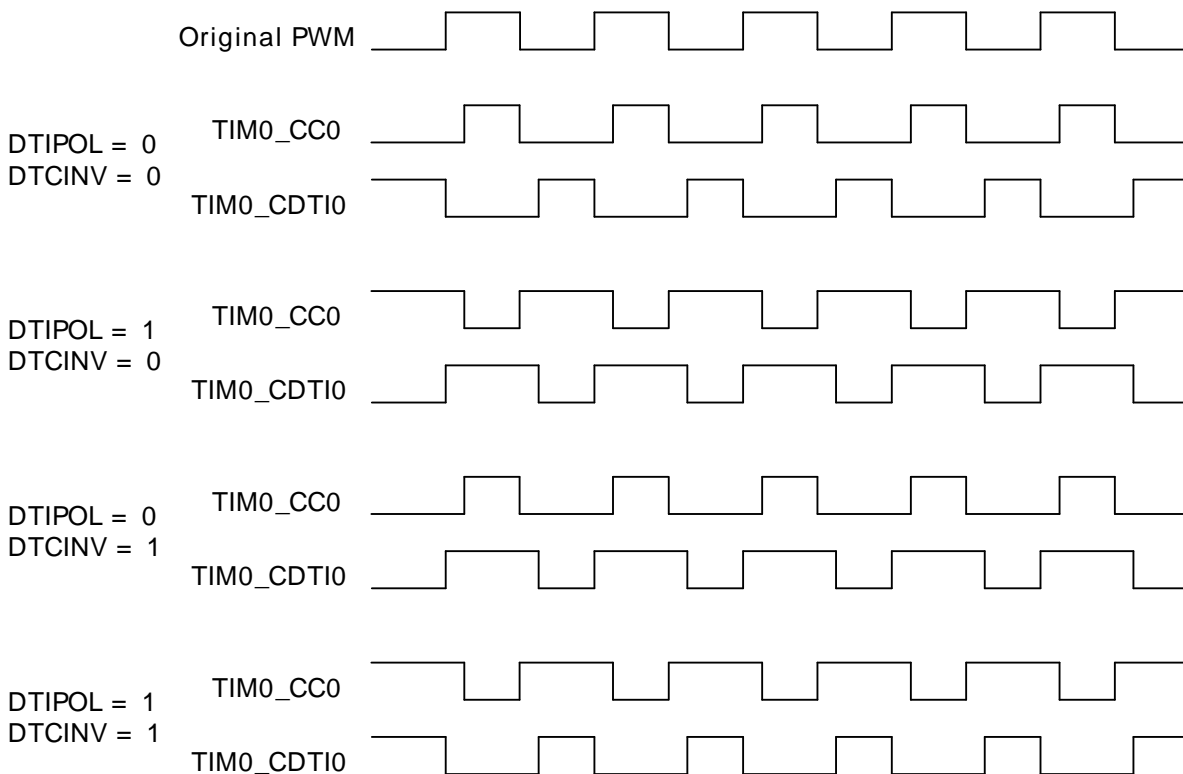

Output generation on the individual DTI outputs can be disabled by configuring `TIMER0_DTOGEN`. When output generation on an output is disabled, it will go to and stay in its inactive state.

19.3.3.2 PRS Channel as Source

A PRS channel can optionally be used as input to the DTI module instead of the PWM output from the timer. Setting DTPRSEN in TIMER0_DTCTRL will override the source of the first DTI channel, driving TIM0_CC0 and TIM0_CDTI0, with the value on the PRS channel. The rest of the DTI channels will continue to be driven by the PWM output from the timer. The PRS channel to use is chosen by configuring DTPRSSEL in TIMER0_DTCTRL. Note that the timer must be running even when PRS is used as DTI source.

The DTI prescaler, set by DTPRESC in TIMER0_DTTIME determines with which accuracy the DTI can insert dead-time into a PRS signal. The maximum dead-time error equals 2^{DTPRESC} clock cycles. With zero prescaling, the inserted dead-times are therefore accurate, but they may be inaccurate for larger prescaler settings.

19.3.3.3 Fault Handling

The fault handling system of the DTI unit allows the outputs of the DTI unit to be put in a well-defined state in case of a fault. This hardware fault handling system makes a fast reaction to faults possible, reducing the possibility of damage to the system.

The fault sources which trigger a fault in the DTI module are determined by TIMER0_DTFSEN. Any combination of the available error sources can be selected:

- PRS source 0, determined by DTPRS0FSEL in TIMER0_DTFC
- PRS source 1, determined by DTPRS1FSEL in TIMER0_DTFC
- Debugger
- Core Lockup

One or two PRS channels can be used as an error source. When PRS source 0 is selected as an error source, DTPRS0FSEL determines which PRS channel is used for this source. DTPRS1FSEL determines which PRS channel is selected as PRS source 1. Please note that for Core Lockup, the LOCKUPRDIS in RMU_CTRL must be set. Otherwise this will generate a full reset of the EFM32.

19.3.3.3.1 Action on Fault

When a fault occurs, the bit representing the fault source is set in DTFS, and the outputs from the DTI unit are set to a well-defined state. The following options are available, and can be enabled by configuring DTFACT in TIMER0_DTFC:

- Set outputs to inactive level
- Clear outputs
- Tristate outputs

With the first option enabled, the output state in case of a fault depends on the polarity settings for the individual outputs. An output set to be active high will be set low if a fault is detected, while an output set to be active low will be driven high.

When a fault occurs, the fault source(s) can be read out of TIMER0_DTFS. TIMER0_DTFS is organized in the same way as DTFSEN, with one bit for each source.

19.3.3.3.2 Exiting Fault State

When a fault is triggered by the PRS system, software intervention is required to re-enable the outputs of the DTI unit. This is done by manually clearing TIMER0_DTFS. If the fault cause, determined by TIMER0_DTFS, is the debugger alone, the outputs can optionally be re-enabled when the debugger exits and the processor resumes normal operation. The corresponding bit in TIMER0_DTFS will in that case be cleared by hardware. The automatic startup functionality can be enabled by setting DTDAS in

TIMER0_DTCTRL. If more bits are still set in DTFS when the automatic startup functionality has cleared the debugger bit, the DTI module does not exit the fault state. The fault state is only exited when all the bits in TIMER0_DTFS have been cleared.

19.3.3.4 Configuration Lock

To prevent software errors from making changes to the DTI configuration, a configuration lock is available. Writing any value but 0xCE80 to LOCKKEY in TIMER0_DTLOCK results in TIMER0_DTFC, TIMER0_DTCTRL, TIMER0_DTTIME and TIMER0_ROUTE being locked for writing. To unlock the registers, write 0xCE80 to LOCKKEY in TIMER0_DTLOCK. The value of TIMER0_DTLOCK is 1 when the lock is active, and 0 when the registers are unlocked.

19.3.4 Debug Mode

When the CPU is halted in debug mode, the Timer can be configured to either continue to run or to be frozen. This is configured in DBGHALT in TIMERN_CTRL.

19.3.5 Interrupts, DMA and PRS Output

The Timer has 5 output events:

- Counter Underflow
- Counter Overflow
- Compare match or input capture (one per Compare/Capture channel)

Each of the events has its own interrupt flag. Also, there is one interrupt flag for each Compare/Capture channel which is set on buffer overflow in capture mode. Buffer overflow happens when a new capture pushes an old unread capture out of the TIMERN_CCx_CCv/TIMERN_CCx_CCVB register pair.

If the interrupt flags are set and the corresponding interrupt enable bits in TIMERN_IEN) are set high, the Timer will send out an interrupt request. Each of the events will also lead to a one HFPERCLK_{TIMERN} cycle high pulse on individual PRS outputs.

Each of the events will also set a DMA request when they occur. The different DMA requests are cleared when certain acknowledge conditions are met, see Table 19.3 (p. 259) . If DMACLRACT is set in TIMERN_CTRL, the DMA request is cleared when the triggered DMA channel is active, without having to access any timer registers.

Table 19.3. TIMER Events

Event	Acknowledge
Underflow/Overflow	Read or write to TIMERN_CNT or TIMERN_TOPB
CC 0	Read or write to TIMERN_CC0_CCv or TIMERN_CC0_CCVB
CC 1	Read or write to TIMERN_CC1_CCv or TIMERN_CC1_CCVB
CC 2	Read or write to TIMERN_CC2_CCv or TIMERN_CC2_CCVB

19.3.6 GPIO Input/Output

The TIMn_CCx inputs/outputs and TIM0_CDTIx outputs are accessible as alternate functions through GPIO. Each pin connection can be enabled/disabled separately by setting the corresponding CCxPEN or CDTIxPEN bits in TIMERN_ROUTE. The LOCATION bits in the same register can be used to move all enabled pins to alternate pins.

19.4 Register Map

The offset register address is relative to the registers base address.

Offset	Name	Type	Description
0x000	TIMERn_CTRL	RW	Control Register
0x004	TIMERn_CMD	W1	Command Register
0x008	TIMERn_STATUS	R	Status Register
0x00C	TIMERn_IEN	RW	Interrupt Enable Register
0x010	TIMERn_IF	R	Interrupt Flag Register
0x014	TIMERn_IFS	W1	Interrupt Flag Set Register
0x018	TIMERn_IFC	W1	Interrupt Flag Clear Register
0x01C	TIMERn_TOP	RWH	Counter Top Value Register
0x020	TIMERn_TOPB	RW	Counter Top Value Buffer Register
0x024	TIMERn_CNT	RWH	Counter Value Register
0x028	TIMERn_ROUTE	RW	I/O Routing Register
0x030	TIMERn_CC0_CTRL	RW	CC Channel Control Register
0x034	TIMERn_CC0_CCV	RWH	CC Channel Value Register
0x038	TIMERn_CC0_CCVP	R	CC Channel Value Peek Register
0x03C	TIMERn_CC0_CCVB	RWH	CC Channel Buffer Register
0x040	TIMERn_CC1_CTRL	RW	CC Channel Control Register
0x044	TIMERn_CC1_CCV	RWH	CC Channel Value Register
0x048	TIMERn_CC1_CCVP	R	CC Channel Value Peek Register
0x04C	TIMERn_CC1_CCVB	RWH	CC Channel Buffer Register
0x050	TIMERn_CC2_CTRL	RW	CC Channel Control Register
0x054	TIMERn_CC2_CCV	RWH	CC Channel Value Register
0x058	TIMERn_CC2_CCVP	R	CC Channel Value Peek Register
0x05C	TIMERn_CC2_CCVB	RWH	CC Channel Buffer Register
0x070	TIMERn_DTCTRL	RW	DTI Control Register
0x074	TIMERn_DTTIME	RW	DTI Time Control Register
0x078	TIMERn_DTFC	RW	DTI Fault Configuration Register
0x07C	TIMERn_DTOGEN	RW	DTI Output Generation Enable Register
0x080	TIMERn_DTFault	R	DTI Fault Register
0x084	TIMERn_DTFaultC	W1	DTI Fault Clear Register
0x088	TIMERn_DTLock	RW	DTI Configuration Lock Register

19.5 Register Description

19.5.1 TIMERN_CTRL - Control Register

Offset	Bit Position																																																			
0x000	31	30	29	28	27	26	25	24	23	22	21	20	19	18	17	16	15	14	13	12	11	10	9	8	7	6	5	4	3	2	1	0																				
Reset					0x0								0x0								0x0								0x0																							
Access					RW								RW								RW				RW				RW				RW																			
Name					PRESC								CLKSEL								FALLA				RISEA				DMACLRACT				DEBUGRUN				QDM				OSMEN				SYNC				MODE			

Bit	Name	Reset	Access	Description
31:28	Reserved	To ensure compatibility with future devices, always write bits to 0. More information in Section 2.1 (p. 3)		

27:24	PRESC	0x0	RW	Prescaler Setting
-------	-------	-----	----	--------------------------

These bits select the prescaling factor.

Value	Mode	Description
0	DIV1	The HFPERCLK is undivided
1	DIV2	The HFPERCLK is divided by 2
2	DIV4	The HFPERCLK is divided by 4
3	DIV8	The HFPERCLK is divided by 8
4	DIV16	The HFPERCLK is divided by 16
5	DIV32	The HFPERCLK is divided by 32
6	DIV64	The HFPERCLK is divided by 64
7	DIV128	The HFPERCLK is divided by 128
8	DIV256	The HFPERCLK is divided by 256
9	DIV512	The HFPERCLK is divided by 512
10	DIV1024	The HFPERCLK is divided by 1024

23:18	Reserved	To ensure compatibility with future devices, always write bits to 0. More information in Section 2.1 (p. 3)		
-------	----------	---	--	--

17:16	CLKSEL	0x0	RW	Clock Source Select
-------	--------	-----	----	----------------------------

These bits select the clock source for the timer.

Value	Mode	Description
0	PRESCHFPERCLK	Prescaled HFPERCLK
1	CC1	Compare/Capture Channel 1 Input
2	TIMEROUF	Timer is clocked by underflow(down-count) or overflow(up-count) in the lower numbered neighbor Timer

15:12	Reserved	To ensure compatibility with future devices, always write bits to 0. More information in Section 2.1 (p. 3)		
-------	----------	---	--	--

11:10	FALLA	0x0	RW	Timer Falling Input Edge Action
-------	-------	-----	----	--

These bits select the action taken in the counter when a falling edge occurs on the input.

Value	Mode	Description
0	NONE	No action
1	START	Start counter without reload
2	STOP	Stop counter without reload
3	RELOADSTART	Reload and start counter

9:8	RISEA	0x0	RW	Timer Rising Input Edge Action
-----	-------	-----	----	---------------------------------------

These bits select the action taken in the counter when a rising edge occurs on the input.

Value	Mode	Description
0	NONE	No action
1	START	Start counter without reload
2	STOP	Stop counter without reload

Bit	Name	Reset	Access	Description
	Value	Mode		Description
	3	RELOADSTART		Reload and start counter
7	DMACLRACT	0	RW	DMA Request Clear on Active When this bit is set, the DMA requests are cleared when the corresponding DMA channel is active. This enables the timer DMA requests to be cleared without accessing the timer.
6	DEBUGRUN	0	RW	Debug Mode Run Enable Set this bit to enable timer to run in debug mode.
	Value	Description		
	0	Timer is frozen in debug mode		
	1	Timer is running in debug mode		
5	QDM	0	RW	Quadrature Decoder Mode Selection This bit sets the mode for the quadrature decoder.
	Value	Mode	Description	
	0	X2	X2 mode selected	
	1	X4	X4 mode selected	
4	OSMEN	0	RW	One-shot Mode Enable Enable/disable one shot mode.
3	SYNC	0	RW	Timer Start/Stop/Reload Synchronization When this bit is set, the Timer is started/stopped/reloaded by start/stop/reload commands in the other timers
	Value	Description		
	0	Timer is not started/stopped/reloaded by other timers		
	1	Timer is started/stopped/reloaded by other timers		
2	<i>Reserved To ensure compatibility with future devices, always write bits to 0. More information in Section 2.1 (p. 3)</i>			
1:0	MODE	0x0	RW	Timer Mode These bit set the counting mode for the Timer. Note, when Quadrature Decoder Mode is selected (MODE = 'b11), the CLKSEL is don't care. The Timer is clocked by the Decoder Mode clock output.
	Value	Mode	Description	
	0	UP	Up-count mode	
	1	DOWN	Down-count mode	
	2	UPDOWN	Up/down-count mode	
	3	QDEC	Quadrature decoder mode	

19.5.2 TIMERn_CMD - Command Register

Offset	Bit Position																															
0x004	31	30	29	28	27	26	25	24	23	22	21	20	19	18	17	16	15	14	13	12	11	10	9	8	7	6	5	4	3	2	1	0
Reset																															0	0
Access																															W1	W1
Name																															STOP	START

Bit	Name	Reset	Access	Description
31:2	<i>Reserved To ensure compatibility with future devices, always write bits to 0. More information in Section 2.1 (p. 3)</i>			
1	STOP	0	W1	Stop Timer Write a 1 to this bit to stop timer
0	START	0	W1	Start Timer

Bit	Name	Reset	Access	Description
Write a 1 to this bit to start timer				

19.5.3 TIMERN_STATUS - Status Register

Offset	Bit Position																																	
	31	30	29	28	27	26	25	24	23	22	21	20	19	18	17	16	15	14	13	12	11	10	9	8	7	6	5	4	3	2	1	0		
0x008																																		
Reset						0	0	0						0	0	0																0	0	0
Access						R	R	R						R	R	R																R	R	R
Name						CCPOL2	CCPOL1	CCPOL0						ICV2	ICV1	ICV0																TOPBV	DIR	RUNNING

Bit	Name	Reset	Access	Description
31:27	Reserved	To ensure compatibility with future devices, always write bits to 0. More information in Section 2.1 (p. 3)		

26	CCPOL2	0	R	CC2 Polarity
----	--------	---	---	---------------------

In Input Capture mode, this bit indicates the polarity of the edge that triggered capture in TIMERN_CC2_CCV. In Compare/PWM mode, this bit indicates the polarity of the selected input to CC channel 2. These bits are cleared when CCMODE is written to 0b00 (Off).

Value	Mode	Description
0	LOWRISE	CC2 polarity low level/rising edge
1	HIGHFALL	CC2 polarity high level/falling edge

25	CCPOL1	0	R	CC1 Polarity
----	--------	---	---	---------------------

In Input Capture mode, this bit indicates the polarity of the edge that triggered capture in TIMERN_CC1_CCV. In Compare/PWM mode, this bit indicates the polarity of the selected input to CC channel 1. These bits are cleared when CCMODE is written to 0b00 (Off).

Value	Mode	Description
0	LOWRISE	CC1 polarity low level/rising edge
1	HIGHFALL	CC1 polarity high level/falling edge

24	CCPOL0	0	R	CC0 Polarity
----	--------	---	---	---------------------

In Input Capture mode, this bit indicates the polarity of the edge that triggered capture in TIMERN_CC0_CCV. In Compare/PWM mode, this bit indicates the polarity of the selected input to CC channel 0. These bits are cleared when CCMODE is written to 0b00 (Off).

Value	Mode	Description
0	LOWRISE	CC0 polarity low level/rising edge
1	HIGHFALL	CC0 polarity high level/falling edge

23:19	Reserved	To ensure compatibility with future devices, always write bits to 0. More information in Section 2.1 (p. 3)		
-------	----------	---	--	--

18	ICV2	0	R	CC2 Input Capture Valid
----	------	---	---	--------------------------------

This bit indicates that TIMERN_CC2_CCV contains a valid capture value. These bits are only used in input capture mode and are cleared when CCMODE is written to 0b00 (Off).

Value	Description
0	TIMERN_CC2_CCV does not contain a valid capture value(FIFO empty)
1	TIMERN_CC2_CCV contains a valid capture value(FIFO not empty)

17	ICV1	0	R	CC1 Input Capture Valid
----	------	---	---	--------------------------------

This bit indicates that TIMERN_CC1_CCV contains a valid capture value. These bits are only used in input capture mode and are cleared when CCMODE is written to 0b00 (Off).

Value	Description
0	TIMERN_CC1_CCV does not contain a valid capture value(FIFO empty)
1	TIMERN_CC1_CCV contains a valid capture value(FIFO not empty)

16	ICV0	0	R	CC0 Input Capture Valid
----	------	---	---	--------------------------------

Bit	Name	Reset	Access	Description									
<p>This bit indicates that TIMERNn_CC0_CC0V contains a valid capture value. These bits are only used in input capture mode and are cleared when CCMODE is written to 0b00 (Off).</p> <table border="1"> <thead> <tr> <th>Value</th> <th>Description</th> </tr> </thead> <tbody> <tr> <td>0</td> <td>TIMERNn_CC0_CC0V does not contain a valid capture value(FIFO empty)</td> </tr> <tr> <td>1</td> <td>TIMERNn_CC0_CC0V contains a valid capture value(FIFO not empty)</td> </tr> </tbody> </table>					Value	Description	0	TIMERNn_CC0_CC0V does not contain a valid capture value(FIFO empty)	1	TIMERNn_CC0_CC0V contains a valid capture value(FIFO not empty)			
Value	Description												
0	TIMERNn_CC0_CC0V does not contain a valid capture value(FIFO empty)												
1	TIMERNn_CC0_CC0V contains a valid capture value(FIFO not empty)												
15:11	<p><i>Reserved</i> To ensure compatibility with future devices, always write bits to 0. More information in Section 2.1 (p. 3)</p>												
10	CCVBV2	0	R	CC2 CCVB Valid									
<p>This field indicates that the TIMERNn_CC2_CCVB registers contain data which have not been written to TIMERNn_CC2_CC0V. These bits are only used in output compare/pwm mode and are cleared when CCMODE is written to 0b00 (Off).</p> <table border="1"> <thead> <tr> <th>Value</th> <th>Description</th> </tr> </thead> <tbody> <tr> <td>0</td> <td>TIMERNn_CC2_CCVB does not contain valid data</td> </tr> <tr> <td>1</td> <td>TIMERNn_CC2_CCVB contains valid data which will be written to TIMERNn_CC2_CC0V on the next update event</td> </tr> </tbody> </table>					Value	Description	0	TIMERNn_CC2_CCVB does not contain valid data	1	TIMERNn_CC2_CCVB contains valid data which will be written to TIMERNn_CC2_CC0V on the next update event			
Value	Description												
0	TIMERNn_CC2_CCVB does not contain valid data												
1	TIMERNn_CC2_CCVB contains valid data which will be written to TIMERNn_CC2_CC0V on the next update event												
9	CCVBV1	0	R	CC1 CCVB Valid									
<p>This field indicates that the TIMERNn_CC1_CCVB registers contain data which have not been written to TIMERNn_CC1_CC0V. These bits are only used in output compare/pwm mode and are cleared when CCMODE is written to 0b00 (Off).</p> <table border="1"> <thead> <tr> <th>Value</th> <th>Description</th> </tr> </thead> <tbody> <tr> <td>0</td> <td>TIMERNn_CC1_CCVB does not contain valid data</td> </tr> <tr> <td>1</td> <td>TIMERNn_CC1_CCVB contains valid data which will be written to TIMERNn_CC1_CC0V on the next update event</td> </tr> </tbody> </table>					Value	Description	0	TIMERNn_CC1_CCVB does not contain valid data	1	TIMERNn_CC1_CCVB contains valid data which will be written to TIMERNn_CC1_CC0V on the next update event			
Value	Description												
0	TIMERNn_CC1_CCVB does not contain valid data												
1	TIMERNn_CC1_CCVB contains valid data which will be written to TIMERNn_CC1_CC0V on the next update event												
8	CCVBV0	0	R	CC0 CCVB Valid									
<p>This field indicates that the TIMERNn_CC0_CCVB registers contain data which have not been written to TIMERNn_CC0_CC0V. These bits are only used in output compare/pwm mode and are cleared when CCMODE is written to 0b00 (Off).</p> <table border="1"> <thead> <tr> <th>Value</th> <th>Description</th> </tr> </thead> <tbody> <tr> <td>0</td> <td>TIMERNn_CC0_CCVB does not contain valid data</td> </tr> <tr> <td>1</td> <td>TIMERNn_CC0_CCVB contains valid data which will be written to TIMERNn_CC0_CC0V on the next update event</td> </tr> </tbody> </table>					Value	Description	0	TIMERNn_CC0_CCVB does not contain valid data	1	TIMERNn_CC0_CCVB contains valid data which will be written to TIMERNn_CC0_CC0V on the next update event			
Value	Description												
0	TIMERNn_CC0_CCVB does not contain valid data												
1	TIMERNn_CC0_CCVB contains valid data which will be written to TIMERNn_CC0_CC0V on the next update event												
7:3	<p><i>Reserved</i> To ensure compatibility with future devices, always write bits to 0. More information in Section 2.1 (p. 3)</p>												
2	TOPBV	0	R	TOPB Valid									
<p>This indicates that TIMERNn_TOPB contains valid data that has not been written to TIMERNn_TOP. This bit is also cleared when TIMERNn_TOP is written.</p> <table border="1"> <thead> <tr> <th>Value</th> <th>Description</th> </tr> </thead> <tbody> <tr> <td>0</td> <td>TIMERNn_TOPB does not contain valid data</td> </tr> <tr> <td>1</td> <td>TIMERNn_TOPB contains valid data which will be written to TIMERNn_TOP on the next update event</td> </tr> </tbody> </table>					Value	Description	0	TIMERNn_TOPB does not contain valid data	1	TIMERNn_TOPB contains valid data which will be written to TIMERNn_TOP on the next update event			
Value	Description												
0	TIMERNn_TOPB does not contain valid data												
1	TIMERNn_TOPB contains valid data which will be written to TIMERNn_TOP on the next update event												
1	DIR	0	R	Direction									
<p>Indicates count direction.</p> <table border="1"> <thead> <tr> <th>Value</th> <th>Mode</th> <th>Description</th> </tr> </thead> <tbody> <tr> <td>0</td> <td>UP</td> <td>Counting up</td> </tr> <tr> <td>1</td> <td>DOWN</td> <td>Counting down</td> </tr> </tbody> </table>					Value	Mode	Description	0	UP	Counting up	1	DOWN	Counting down
Value	Mode	Description											
0	UP	Counting up											
1	DOWN	Counting down											
0	RUNNING	0	R	Running									
<p>Indicates if timer is running or not.</p>													

19.5.4 TIMERNn_IEN - Interrupt Enable Register

Offset	Bit Position																																		
	31	30	29	28	27	26	25	24	23	22	21	20	19	18	17	16	15	14	13	12	11	10	9	8	7	6	5	4	3	2	1	0			
0x00C																																			
Reset																							0	0	0		0	0	0						
Access																							RW	RW	RW		RW	RW	RW						
Name																							ICBOF2	ICBOF1	ICBOF0			CC2	CC1	CC0			UF	OF	

Bit	Name	Reset	Access	Description
31:11	Reserved	To ensure compatibility with future devices, always write bits to 0. More information in Section 2.1 (p. 3)		
10	ICBOF2	0	RW	CC Channel 2 Input Capture Buffer Overflow Interrupt Enable Enable/disable Compare/Capture ch 2 input capture buffer overflow interrupt.
9	ICBOF1	0	RW	CC Channel 1 Input Capture Buffer Overflow Interrupt Enable Enable/disable Compare/Capture ch 1 input capture buffer overflow interrupt.
8	ICBOF0	0	RW	CC Channel 0 Input Capture Buffer Overflow Interrupt Enable Enable/disable Compare/Capture ch 0 input capture buffer overflow interrupt.
7	Reserved	To ensure compatibility with future devices, always write bits to 0. More information in Section 2.1 (p. 3)		
6	CC2	0	RW	CC Channel 2 Interrupt Enable Enable/disable Compare/Capture ch 2 interrupt.
5	CC1	0	RW	CC Channel 1 Interrupt Enable Enable/disable Compare/Capture ch 1 interrupt.
4	CC0	0	RW	CC Channel 0 Interrupt Enable Enable/disable Compare/Capture ch 0 interrupt.
3:2	Reserved	To ensure compatibility with future devices, always write bits to 0. More information in Section 2.1 (p. 3)		
1	UF	0	RW	Underflow Interrupt Enable Enable/disable underflow interrupt.
0	OF	0	RW	Overflow Interrupt Enable Enable/disable overflow interrupt.

19.5.5 TIMERn_IF - Interrupt Flag Register

Offset	Bit Position																																																		
0x010	31	30	29	28	27	26	25	24	23	22	21	20	19	18	17	16	15	14	13	12	11	10	9	8	7	6	5	4	3	2	1	0																			
Reset																	0	0	0		0	0	0																												
Access																	R	R	R		R	R	R																												
Name																	ICBOF2	ICBOF1	ICBOF0																																

Bit	Name	Reset	Access	Description
31:11	Reserved	To ensure compatibility with future devices, always write bits to 0. More information in Section 2.1 (p. 3)		
10	ICBOF2	0	R	CC Channel 2 Input Capture Buffer Overflow Interrupt Flag This bit indicates that a new capture value has pushed an unread value out of the TIMERn_CC2_CCV/TIMERn_CC2_CCVB register pair.
9	ICBOF1	0	R	CC Channel 1 Input Capture Buffer Overflow Interrupt Flag This bit indicates that a new capture value has pushed an unread value out of the TIMERn_CC1_CCV/TIMERn_CC1_CCVB register pair.
8	ICBOF0	0	R	CC Channel 0 Input Capture Buffer Overflow Interrupt Flag This bit indicates that a new capture value has pushed an unread value out of the TIMERn_CC0_CCV/TIMERn_CC0_CCVB register pair.
7	Reserved	To ensure compatibility with future devices, always write bits to 0. More information in Section 2.1 (p. 3)		
6	CC2	0	R	CC Channel 2 Interrupt Flag This bit indicates that there has been an interrupt event on Compare/Capture channel 2.
5	CC1	0	R	CC Channel 1 Interrupt Flag

Bit	Name	Reset	Access	Description
				This bit indicates that there has been an interrupt event on Compare/Capture channel 1.
4	CC0	0	R	CC Channel 0 Interrupt Flag This bit indicates that there has been an interrupt event on Compare/Capture channel 0.
3:2	<i>Reserved</i>	<i>To ensure compatibility with future devices, always write bits to 0. More information in Section 2.1 (p. 3)</i>		
1	UF	0	R	Underflow Interrupt Flag This bit indicates that there has been an underflow.
0	OF	0	R	Overflow Interrupt Flag This bit indicates that there has been an overflow.

19.5.6 TIMERN_IFS - Interrupt Flag Set Register

Offset	Bit Position																																																				
0x014	31	30	29	28	27	26	25	24	23	22	21	20	19	18	17	16	15	14	13	12	11	10	9	8	7	6	5	4	3	2	1	0																					
Reset																								0	0	0																											
Access																								W1	W1	W1																											
Name																								ICBOF2	ICBOF1	ICBOF0																											

Bit	Name	Reset	Access	Description
31:11	<i>Reserved</i>	<i>To ensure compatibility with future devices, always write bits to 0. More information in Section 2.1 (p. 3)</i>		
10	ICBOF2	0	W1	CC Channel 2 Input Capture Buffer Overflow Interrupt Flag Set Writing a 1 to this bit will set Compare/Capture channel 2 input capture buffer overflow interrupt flag.
9	ICBOF1	0	W1	CC Channel 1 Input Capture Buffer Overflow Interrupt Flag Set Writing a 1 to this bit will set Compare/Capture channel 1 input capture buffer overflow interrupt flag.
8	ICBOF0	0	W1	CC Channel 0 Input Capture Buffer Overflow Interrupt Flag Set Writing a 1 to this bit will set Compare/Capture channel 0 input capture buffer overflow interrupt flag.
7	<i>Reserved</i>	<i>To ensure compatibility with future devices, always write bits to 0. More information in Section 2.1 (p. 3)</i>		
6	CC2	0	W1	CC Channel 2 Interrupt Flag Set Writing a 1 to this bit will set Compare/Capture channel 2 interrupt flag.
5	CC1	0	W1	CC Channel 1 Interrupt Flag Set Writing a 1 to this bit will set Compare/Capture channel 1 interrupt flag.
4	CC0	0	W1	CC Channel 0 Interrupt Flag Set Writing a 1 to this bit will set Compare/Capture channel 0 interrupt flag.
3:2	<i>Reserved</i>	<i>To ensure compatibility with future devices, always write bits to 0. More information in Section 2.1 (p. 3)</i>		
1	UF	0	W1	Underflow Interrupt Flag Set Writing a 1 to this bit will set the underflow interrupt flag.
0	OF	0	W1	Overflow Interrupt Flag Set Writing a 1 to this bit will set the overflow interrupt flag.

19.5.7 TIMERN_IFC - Interrupt Flag Clear Register

Offset	Bit Position																																																				
	31	30	29	28	27	26	25	24	23	22	21	20	19	18	17	16	15	14	13	12	11	10	9	8	7	6	5	4	3	2	1	0																					
0x018																																																					
Reset																																																					
Access																							W1	W1	W1		W1	W1	W1																								
Name																							ICBOF2	ICBOF1	ICBOF0																												

Bit	Name	Reset	Access	Description
31:11	Reserved	To ensure compatibility with future devices, always write bits to 0. More information in Section 2.1 (p. 3)		
10	ICBOF2	0	W1	CC Channel 2 Input Capture Buffer Overflow Interrupt Flag Clear Writing a 1 to this bit will clear Compare/Capture channel 2 input capture buffer overflow interrupt flag.
9	ICBOF1	0	W1	CC Channel 1 Input Capture Buffer Overflow Interrupt Flag Clear Writing a 1 to this bit will clear Compare/Capture channel 1 input capture buffer overflow interrupt flag.
8	ICBOF0	0	W1	CC Channel 0 Input Capture Buffer Overflow Interrupt Flag Clear Writing a 1 to this bit will clear Compare/Capture channel 0 input capture buffer overflow interrupt flag.
7	Reserved	To ensure compatibility with future devices, always write bits to 0. More information in Section 2.1 (p. 3)		
6	CC2	0	W1	CC Channel 2 Interrupt Flag Clear Writing a 1 to this bit will clear Compare/Capture interrupt flag 2.
5	CC1	0	W1	CC Channel 1 Interrupt Flag Clear Writing a 1 to this bit will clear Compare/Capture interrupt flag 1.
4	CC0	0	W1	CC Channel 0 Interrupt Flag Clear Writing a 1 to this bit will clear Compare/Capture interrupt flag 0.
3:2	Reserved	To ensure compatibility with future devices, always write bits to 0. More information in Section 2.1 (p. 3)		
1	UF	0	W1	Underflow Interrupt Flag Clear Writing a 1 to this bit will clear the underflow interrupt flag.
0	OF	0	W1	Overflow Interrupt Flag Clear Writing a 1 to this bit will clear th overflow interrupt flag.

19.5.8 TIMERN_TOP - Counter Top Value Register

Offset	Bit Position																																
	31	30	29	28	27	26	25	24	23	22	21	20	19	18	17	16	15	14	13	12	11	10	9	8	7	6	5	4	3	2	1	0	
0x01C																																	
Reset																																	0xFFFF
Access																																	RWH
Name																																	TOP

Bit	Name	Reset	Access	Description
31:16	Reserved	To ensure compatibility with future devices, always write bits to 0. More information in Section 2.1 (p. 3)		
15:0	TOP	0xFFFF	RWH	Counter Top Value

Bit	Name	Reset	Access	Description
-----	------	-------	--------	-------------

These bits hold the TOP value for the counter.

19.5.9 TIMERN_TOPB - Counter Top Value Buffer Register

Offset	Bit Position																															
0x020	31	30	29	28	27	26	25	24	23	22	21	20	19	18	17	16	15	14	13	12	11	10	9	8	7	6	5	4	3	2	1	0
Reset																	0x0000															
Access																	RW															
Name																	TOPB															

Bit	Name	Reset	Access	Description
31:16	Reserved	To ensure compatibility with future devices, always write bits to 0. More information in Section 2.1 (p. 3)		
15:0	TOPB	0x0000	RW	Counter Top Value Buffer

These bits hold the TOP buffer value.

19.5.10 TIMERN_CNT - Counter Value Register

Offset	Bit Position																															
0x024	31	30	29	28	27	26	25	24	23	22	21	20	19	18	17	16	15	14	13	12	11	10	9	8	7	6	5	4	3	2	1	0
Reset																	0x0000															
Access																	RWH															
Name																	CNT															

Bit	Name	Reset	Access	Description
31:16	Reserved	To ensure compatibility with future devices, always write bits to 0. More information in Section 2.1 (p. 3)		
15:0	CNT	0x0000	RWH	Counter Value

These bits hold the counter value.

19.5.11 TIMERN_ROUTE - I/O Routing Register

Offset	Bit Position																																																									
0x028	31	30	29	28	27	26	25	24	23	22	21	20	19	18	17	16	15	14	13	12	11	10	9	8	7	6	5	4	3	2	1	0																										
Reset																	0x0																0		0		0																					
Access																	RW																RW		RW		RW																					
Name																	LOCATION																CDT12PEN		CDT11PEN		CDT10PEN																CC2PEN		CC1PEN		CC0PEN	

Bit	Name	Reset	Access	Description
31:18	Reserved	To ensure compatibility with future devices, always write bits to 0. More information in Section 2.1 (p. 3)		
17:16	LOCATION	0x0	RW	I/O Location Decides the location of the CC and CDTI pins.
	Value	Mode	Description	
	0	LOC0	Location 0	
	1	LOC1	Location 1	
	2	LOC2	Location 2	
	3	LOC3	Location 3	
15:11	Reserved	To ensure compatibility with future devices, always write bits to 0. More information in Section 2.1 (p. 3)		
10	CDTI2PEN	0	RW	CC Channel 2 Complementary Dead-Time Insertion Pin Enable Enable/disable CC channel 2 complementary dead-time insertion output connection to pin.
9	CDTI1PEN	0	RW	CC Channel 1 Complementary Dead-Time Insertion Pin Enable Enable/disable CC channel 1 complementary dead-time insertion output connection to pin.
8	CDTI0PEN	0	RW	CC Channel 0 Complementary Dead-Time Insertion Pin Enable Enable/disable CC channel 0 complementary dead-time insertion output connection to pin.
7:3	Reserved	To ensure compatibility with future devices, always write bits to 0. More information in Section 2.1 (p. 3)		
2	CC2PEN	0	RW	CC Channel 2 Pin Enable Enable/disable CC channel 2 output/input connection to pin.
1	CC1PEN	0	RW	CC Channel 1 Pin Enable Enable/disable CC channel 1 output/input connection to pin.
0	CC0PEN	0	RW	CC Channel 0 Pin Enable Enable/disable CC Channel 0 output/input connection to pin.

19.5.12 TIMERNn_CCx_CTRL - CC Channel Control Register

Offset	Bit Position																																
	31	30	29	28	27	26	25	24	23	22	21	20	19	18	17	16	15	14	13	12	11	10	9	8	7	6	5	4	3	2	1	0	
0x030					0x0		0x0			0		0			0x0					0x0		0x0		0x0					0		0		0x0
Reset																																	
Access					RW		RW			RW		RW			RW					RW		RW		RW					RW		RW		RW
Name					ICEVCTRL		ICEDGE			FILT		INSEL			PRSEL					CUFOA		COFOA		CMOA				COIST		OUTINV		MODE	

Bit	Name	Reset	Access	Description
31:28	Reserved	To ensure compatibility with future devices, always write bits to 0. More information in Section 2.1 (p. 3)		
27:26	ICEVCTRL	0x0	RW	Input Capture Event Control These bits control when a Compare/Capture PRS output pulse, interrupt flag and DMA request is set.
	Value	Mode	Description	
	0	EVERYEDGE	PRS output pulse, interrupt flag and DMA request set on every capture	
	1	EVERYSECONDEDGE	PRS output pulse, interrupt flag and DMA request set on every second capture	
	2	RISING	PRS output pulse, interrupt flag and DMA request set on rising edge only (if ICDGE = BOTH)	
	3	FALLING	PRS output pulse, interrupt flag and DMA request set on falling edge only (if ICDGE = BOTH)	

25:24	ICEDGE	0x0	RW	Input Capture Edge Select These bits control which edges the edge detector triggers on. The output is used for input capture and external clock input.
-------	--------	-----	----	--

Bit	Name	Reset	Access	Description
	Value	Mode		Description
	0	RISING		Rising edges detected
	1	FALLING		Falling edges detected
	2	BOTH		Both edges detected
	3	NONE		No edge detection, signal is left as it is
23:22	<i>Reserved</i>		<i>To ensure compatibility with future devices, always write bits to 0. More information in Section 2.1 (p. 3)</i>	
21	FILT	0	RW	Digital Filter
	Enable digital filter.			
	Value	Mode		Description
	0	DISABLE		Digital filter disabled
	1	ENABLE		Digital filter enabled
20	INSEL	0	RW	Input Selection
	Select Compare/Capture channel input.			
	Value	Mode		Description
	0	PIN		TIMERnCCx pin is selected
	1	PRS		PRS input (selected by PRSSEL) is selected
19	<i>Reserved</i>		<i>To ensure compatibility with future devices, always write bits to 0. More information in Section 2.1 (p. 3)</i>	
18:16	PRSSEL	0x0	RW	Compare/Capture Channel PRS Input Channel Selection
	Select PRS input channel for Compare/Capture channel.			
	Value	Mode		Description
	0	PRSCH0		PRS Channel 0 selected as input
	1	PRSCH1		PRS Channel 1 selected as input
	2	PRSCH2		PRS Channel 2 selected as input
	3	PRSCH3		PRS Channel 3 selected as input
	4	PRSCH4		PRS Channel 4 selected as input
	5	PRSCH5		PRS Channel 5 selected as input
	6	PRSCH6		PRS Channel 6 selected as input
	7	PRSCH7		PRS Channel 7 selected as input
15:14	<i>Reserved</i>		<i>To ensure compatibility with future devices, always write bits to 0. More information in Section 2.1 (p. 3)</i>	
13:12	CUFOA	0x0	RW	Counter Underflow Output Action
	Select output action on counter underflow.			
	Value	Mode		Description
	0	NONE		No action on counter underflow
	1	TOGGLE		Toggle output on counter underflow
	2	CLEAR		Clear output on counter underflow
	3	SET		Set output on counter underflow
11:10	COFOA	0x0	RW	Counter Overflow Output Action
	Select output action on counter overflow.			
	Value	Mode		Description
	0	NONE		No action on counter overflow
	1	TOGGLE		Toggle output on counter overflow
	2	CLEAR		Clear output on counter overflow
	3	SET		Set output on counter overflow
9:8	CMOA	0x0	RW	Compare Match Output Action
	Select output action on compare match.			
	Value	Mode		Description
	0	NONE		No action on compare match
	1	TOGGLE		Toggle output on compare match
	2	CLEAR		Clear output on compare match

Bit	Name	Reset	Access	Description
	Value	Mode		Description
	3	SET		Set output on compare match
7:5	<i>Reserved</i> To ensure compatibility with future devices, always write bits to 0. More information in Section 2.1 (p. 3)			
4	COIST	0	RW	Compare Output Initial State This bit is only used in Output Compare and PWM mode. When this bit is set in compare mode, the output is set high when the counter is disabled. When counting resumes, this value will represent the initial value for the output. If the bit is cleared, the output will be cleared when the counter is disabled. In PWM mode, the output will always be low when disabled, regardless of this bit. However, this bit will represent the initial value of the output, once it is enabled.
3	<i>Reserved</i> To ensure compatibility with future devices, always write bits to 0. More information in Section 2.1 (p. 3)			
2	OUTINV	0	RW	Output Invert Setting this bit inverts the output from the CC channel (Output compare, PWM).
1:0	MODE	0x0	RW	CC Channel Mode These bits select the mode for Compare/Capture channel.
	Value	Mode		Description
	0	OFF		Compare/Capture channel turned off
	1	INPUTCAPTURE		Input capture
	2	OUTPUTCOMPARE		Output compare
	3	PWM		Pulse-Width Modulation

19.5.13 TIMERN_CCx_CCv - CC Channel Value Register

Offset	Bit Position																															
0x034	31	30	29	28	27	26	25	24	23	22	21	20	19	18	17	16	15	14	13	12	11	10	9	8	7	6	5	4	3	2	1	0
Reset																	0x0000															
Access																	RWH															
Name																	CCV															

Bit	Name	Reset	Access	Description
31:16	<i>Reserved</i> To ensure compatibility with future devices, always write bits to 0. More information in Section 2.1 (p. 3)			
15:0	CCV	0x0000	RWH	CC Channel Value In input capture mode, this field holds the first unread capture value. When reading this register in input capture mode, then contents of the TIMERN_CCx_CCvB register will be written to TIMERN_CCx_CCv in the next cycle. In compare mode, this field holds the compare value.

19.5.14 TIMERNn_CCx_CCVP - CC Channel Value Peek Register

Offset	Bit Position																															
0x038	31	30	29	28	27	26	25	24	23	22	21	20	19	18	17	16	15	14	13	12	11	10	9	8	7	6	5	4	3	2	1	0
Reset																	0x0000															
Access																	R															
Name																	CCVP															

Bit	Name	Reset	Access	Description
31:16	Reserved	To ensure compatibility with future devices, always write bits to 0. More information in Section 2.1 (p. 3)		
15:0	CCVP	0x0000	R	CC Channel Value Peek This field is used to read the CC value without pulling data through the FIFO in capture mode.

19.5.15 TIMERNn_CCx_CCVB - CC Channel Buffer Register

Offset	Bit Position																															
0x03C	31	30	29	28	27	26	25	24	23	22	21	20	19	18	17	16	15	14	13	12	11	10	9	8	7	6	5	4	3	2	1	0
Reset																	0x0000															
Access																	RWH															
Name																	CCVB															

Bit	Name	Reset	Access	Description
31:16	Reserved	To ensure compatibility with future devices, always write bits to 0. More information in Section 2.1 (p. 3)		
15:0	CCVB	0x0000	RWH	CC Channel Value Buffer In Input Capture mode, this field holds the last capture value if the TIMERNn_CCx_CCVP register already contains an earlier unread capture value. In Output Compare or PWM mode, this field holds the CC buffer value which will be written to TIMERNn_CCx_CCVP on an update event if TIMERNn_CCx_CCVB contains valid data.

19.5.16 TIMERNn_DTCTRL - DTI Control Register

Offset	Bit Position																																						
0x070	31	30	29	28	27	26	25	24	23	22	21	20	19	18	17	16	15	14	13	12	11	10	9	8	7	6	5	4	3	2	1	0							
Reset																								0									0x0		0	0	0	0	0
Access																								RW									RW		RW	RW	RW	RW	RW
Name																								DTPRSEN									DTPRSEL		DTCINV	DTIPOL	DTDAS	DTEN	

Bit	Name	Reset	Access	Description
31:25	Reserved	To ensure compatibility with future devices, always write bits to 0. More information in Section 2.1 (p. 3)		
24	DTPRSEN	0	RW	DTI PRS Source Enable Enable/disable PRS as DTI input.
23:7	Reserved	To ensure compatibility with future devices, always write bits to 0. More information in Section 2.1 (p. 3)		
6:4	DTPRSSEL	0x0	RW	DTI PRS Source Channel Select Select which PRS channel to listen to.
	Value	Mode	Description	
	0	PRSCH0	PRS Channel 0 selected as input	
	1	PRSCH1	PRS Channel 1 selected as input	
	2	PRSCH2	PRS Channel 2 selected as input	
	3	PRSCH3	PRS Channel 3 selected as input	
	4	PRSCH4	PRS Channel 4 selected as input	
	5	PRSCH5	PRS Channel 5 selected as input	
	6	PRSCH6	PRS Channel 6 selected as input	
	7	PRSCH7	PRS Channel 7 selected as input	
3	DTCINV	0	RW	DTI Complementary Output Invert. Set to invert complementary outputs.
2	DTIPOL	0	RW	DTI Inactive Polarity Set inactive polarity for outputs.
1	DTDAS	0	RW	DTI Automatic Start-up Functionality Configure DTI restart on debugger exit.
	Value	Mode	Description	
	0	NORESTART	No DTI restart on debugger exit	
	1	RESTART	DTI restart on debugger exit	
0	DTEN	0	RW	DTI Enable Enable/disable DTI.

19.5.17 TIMERN_DTTIME - DTI Time Control Register

Offset	Bit Position																																			
	31	30	29	28	27	26	25	24	23	22	21	20	19	18	17	16	15	14	13	12	11	10	9	8	7	6	5	4	3	2	1	0				
0x074																	0x00										0x00								0x0	
Reset																	0x00										0x00								0x0	
Access																	RW										RW								RW	
Name																	DTFALLT										DTRISET								DTPRESC	

Bit	Name	Reset	Access	Description
31:22	Reserved	To ensure compatibility with future devices, always write bits to 0. More information in Section 2.1 (p. 3)		
21:16	DTFALLT	0x00	RW	DTI Fall-time Set time span for the falling edge.
	Value	Description		
	DTFALLT	Fall time of DTFALLT+1 prescaled HFPERCLK cycles		
15:14	Reserved	To ensure compatibility with future devices, always write bits to 0. More information in Section 2.1 (p. 3)		
13:8	DTRISET	0x00	RW	DTI Rise-time

Bit	Name	Reset	Access	Description
Set time span for the rising edge.				
Value		Description		
DTRISSET		Rise time of DTRISSET+1 prescaled HFPERCLK cycles		
7:4	Reserved	To ensure compatibility with future devices, always write bits to 0. More information in Section 2.1 (p. 3)		
3:0	DTPRESC	0x0	RW	DTI Prescaler Setting
Select prescaler for DTI.				
Value		Mode		Description
0		DIV1		The HFPERCLK is undivided
1		DIV2		The HFPERCLK is divided by 2
2		DIV4		The HFPERCLK is divided by 4
3		DIV8		The HFPERCLK is divided by 8
4		DIV16		The HFPERCLK is divided by 16
5		DIV32		The HFPERCLK is divided by 32
6		DIV64		The HFPERCLK is divided by 64
7		DIV128		The HFPERCLK is divided by 128
8		DIV256		The HFPERCLK is divided by 256
9		DIV512		The HFPERCLK is divided by 512
10		DIV1024		The HFPERCLK is divided by 1024

19.5.18 TIMERN_DTFC - DTI Fault Configuration Register

Offset	Bit Position																															
0x078	31	30	29	28	27	26	25	24	23	22	21	20	19	18	17	16	15	14	13	12	11	10	9	8	7	6	5	4	3	2	1	0
Reset					0	0	0	0									0x0									0x0					0x0	
Access					RW	RW	RW	RW									RW									RW					RW	
Name					DTLOCKUPFEN	DTDBGFEN	DTPRS1FEN	DTPRS0FEN									DTFA									DTPRS1FSEL					DTPRS0FSEL	

Bit	Name	Reset	Access	Description
31:28	Reserved	To ensure compatibility with future devices, always write bits to 0. More information in Section 2.1 (p. 3)		
27	DTLOCKUPFEN	0	RW	DTI Lockup Fault Enable Set this bit to 1 to enable core lockup as a fault source
26	DTDBGFEN	0	RW	DTI Debugger Fault Enable Set this bit to 1 to enable debugger as a fault source
25	DTPRS1FEN	0	RW	DTI PRS 1 Fault Enable Set this bit to 1 to enable PRS source 1(PRS channel determined by DTPRS1FSEL) as a fault source
24	DTPRS0FEN	0	RW	DTI PRS 0 Fault Enable Set this bit to 1 to enable PRS source 0(PRS channel determined by DTPRS0FSEL) as a fault source
23:18	Reserved	To ensure compatibility with future devices, always write bits to 0. More information in Section 2.1 (p. 3)		
17:16	DTFA	0x0	RW	DTI Fault Action Select fault action.
Value		Mode		Description
0		NONE		No action on fault
1		INACTIVE		Set outputs inactive
2		CLEAR		Clear outputs

Bit	Name	Reset	Access	Description
	Value	Mode		Description
	3	TRISTATE		Tristate outputs
15:11	<i>Reserved To ensure compatibility with future devices, always write bits to 0. More information in Section 2.1 (p. 3)</i>			
10:8	DTPRS1FSEL	0x0	RW	DTI PRS Fault Source 1 Select Select PRS channel for fault source 1.
	Value	Mode		Description
	0	PRSCH0		PRS Channel 0 selected as fault source 1
	1	PRSCH1		PRS Channel 1 selected as fault source 1
	2	PRSCH2		PRS Channel 2 selected as fault source 1
	3	PRSCH3		PRS Channel 3 selected as fault source 1
	4	PRSCH4		PRS Channel 4 selected as fault source 1
	5	PRSCH5		PRS Channel 5 selected as fault source 1
	6	PRSCH6		PRS Channel 6 selected as fault source 1
	7	PRSCH7		PRS Channel 7 selected as fault source 1
7:3	<i>Reserved To ensure compatibility with future devices, always write bits to 0. More information in Section 2.1 (p. 3)</i>			
2:0	DTPRS0FSEL	0x0	RW	DTI PRS Fault Source 0 Select Select PRS channel for fault source 0.
	Value	Mode		Description
	0	PRSCH0		PRS Channel 0 selected as fault source 0
	1	PRSCH1		PRS Channel 1 selected as fault source 0
	2	PRSCH2		PRS Channel 2 selected as fault source 0
	3	PRSCH3		PRS Channel 3 selected as fault source 0
	4	PRSCH4		PRS Channel 4 selected as fault source 0
	5	PRSCH5		PRS Channel 5 selected as fault source 0
	6	PRSCH6		PRS Channel 6 selected as fault source 0
	7	PRSCH7		PRS Channel 7 selected as fault source 0

19.5.19 TIMERN_DTOGEN - DTI Output Generation Enable Register

Offset	Bit Position																															
0x07C	31	30	29	28	27	26	25	24	23	22	21	20	19	18	17	16	15	14	13	12	11	10	9	8	7	6	5	4	3	2	1	0
Reset																											0	0	0	0	0	0
Access																											RW	RW	RW	RW	RW	RW
Name																											DTOGCDT12EN	DTOGCDT11EN	DTOGCDT10EN	DTOGCC2EN	DTOGCC1EN	DTOGCC0EN

Bit	Name	Reset	Access	Description
31:6	<i>Reserved To ensure compatibility with future devices, always write bits to 0. More information in Section 2.1 (p. 3)</i>			
5	DTOGCDT12EN	0	RW	DTI CDT12 Output Generation Enable This bit enables/disables output generation for the CDT12 output from the DTI.
4	DTOGCDT11EN	0	RW	DTI CDT11 Output Generation Enable This bit enables/disables output generation for the CDT11 output from the DTI.
3	DTOGCDT10EN	0	RW	DTI CDT10 Output Generation Enable This bit enables/disables output generation for the CDT10 output from the DTI.
2	DTOGCC2EN	0	RW	DTI CC2 Output Generation Enable This bit enables/disables output generation for the CC2 output from the DTI.

Bit	Name	Reset	Access	Description
1	DTPRS1FC	0	W1	DTI PRS1 Fault Clear Write 1 to this bit to clear PRS 1 fault.
0	DTPRS0FC	0	W1	DTI PRS0 Fault Clear Write 1 to this bit to clear PRS 0 fault.

19.5.22 TIMERn_DTLOCK - DTI Configuration Lock Register

Offset	Bit Position																															
0x088	31	30	29	28	27	26	25	24	23	22	21	20	19	18	17	16	15	14	13	12	11	10	9	8	7	6	5	4	3	2	1	0
Reset																	0x0000															
Access																	RW															
Name																	LOCKKEY															

Bit	Name	Reset	Access	Description
31:16	Reserved	To ensure compatibility with future devices, always write bits to 0. More information in Section 2.1 (p. 3)		

15:0 **LOCKKEY** 0x0000 RW **DTI Lock Key**
 Write any other value than the unlock code to lock TIMER0_ROUTE, TIMER0_DTCTRL, TIMER0_DTTIME and TIMER0_DTFC from editing. Write the unlock code to unlock. When reading the register, bit 0 is set when the lock is enabled.

Mode	Value	Description
Read Operation		
UNLOCKED	0	TIMER DTI registers are unlocked
LOCKED	1	TIMER DTI registers are locked
Write Operation		
LOCK	0	Lock TIMER DTI registers
UNLOCK	0xCE80	Unlock TIMER DTI registers

20 RTC - Real Time Counter

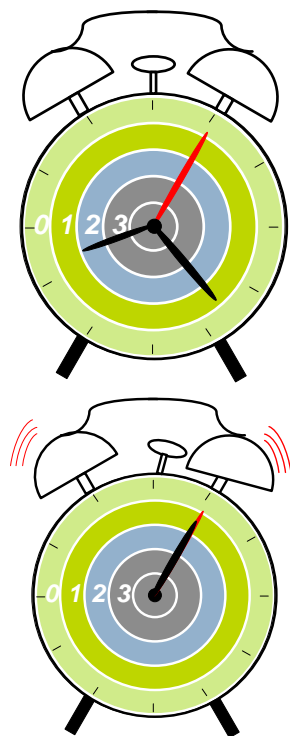

Quick Facts

What?

The Real Time Counter (RTC) ensures timekeeping in low energy modes. Combined with the low power 32.768 kHz oscillator (XTAL or RC), the RTC can run in EM2 with total current consumption less than 0.9 μ A.

Why?

Timekeeping over long time periods is required in many applications, while using as little power as possible.

How?

The 32.768 kHz oscillator is used as clock signal and the RTC has two different compare registers that can trigger a wake-up. 24-bit resolution and selectable prescaling allow the system to stay in EM2 for long a time and still maintain reliable timekeeping.

20.1 Introduction

The Real Time Counter (RTC) contains a 24-bit counter and is clocked either by a 32.768 kHz crystal oscillator, or a 32.768 kHz RC oscillator. In addition to energy modes EM0 and EM1, the RTC is also available in EM2. This makes it ideal for keeping track of time since the RTC is enabled in EM2 where most of the device is powered down.

Two compare channels are available in the RTC. These can be used to trigger interrupts and to wake the device up from a low energy mode. They can also be used with the LETIMER to generate various output waveforms.

20.2 Features

- 24-bit Real Time Counter
- Prescaler
 - 32.768 kHz/ 2^N , N = 0 - 15
 - Overflow @ 0.14 hours for prescaler setting = 0
 - Overflow @ 4660 hours (194 days) for prescaler setting = 15 (1 s tick)
- Two compare registers
 - A compare match can potentially wake-up the device from low energy modes EM1 and EM2
 - Second compare register can be top value for RTC
 - Both compare channels can trigger LETIMER
 - Compare match events are available to other peripherals through the Peripheral Reflex System (PRS)

20.3 Functional Description

The RTC is a 24-bit counter with two compare channels. The RTC is closely coupled with the LETIMER, and can be configured to trigger it on a compare match on one or both compare channels. An overview of the RTC module is shown in Figure 20.1 (p. 279) .

Figure 20.1. RTC Overview

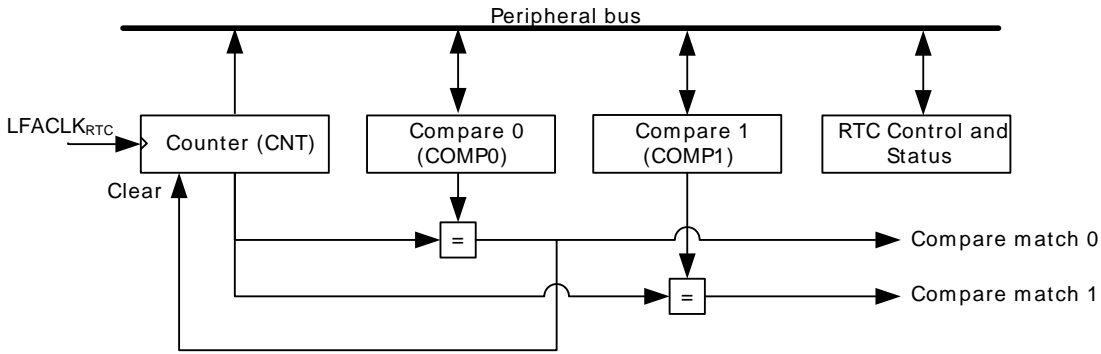

20.3.1 Counter

The RTC is enabled by setting the EN bit in the RTC_CTRL register. It counts up as long as it is enabled, and will on an overflow simply wrap around and continue counting. The RTC is cleared when it is disabled. The timer value is read-only and the RTC always starts counting from 0 when enabled. The value of the counter can be read using the RTC_CNT register.

20.3.1.1 Clock Source

The RTC clock source and its prescaler value are defined in the Register Description section of the Clock Management Unit (CMU). The clock used by the RTC has a frequency given by Equation 20.1 (p. 279) .

RTC Frequency Equation

$$f_{RTC} = f_{LFACLK} / 2^{RTC_PRESC} \tag{20.1}$$

where f_{LFACLK} is the LFACLK frequency (32.768 kHz) and RTC_PRESC is a 4 bit value. Table 20.1 (p. 280) shows the time of overflow and resolution of the RTC at the available prescaler values.

To use this module, the LE interface clock must be enabled in CMU_HFCORECLKEN0 in addition to the module clock

Table 20.1. RTC Resolution Vs Overflow

RTC_PRESC	Resolution	Overflow
0	30,5 μ s	512 s
1	61,0 μ s	1024 s
2	122 μ s	2048 s
3	244 μ s	1,14 hours
4	488 μ s	2,28 hours
5	977 μ s	4,55 hours
6	1,95 ms	9,10 hours
7	3,91 ms	18,2 hours
8	7,81 ms	1,52 days
9	15,6 ms	3,03 days
10	31,25 ms	6,07 days
11	62,5 ms	12,1 days
12	0,125 s	24,3 days
13	0,25 s	48,5 days
14	0,5 s	97,1 days
15	1 s	194 days

20.3.2 Compare Channels

Two compare channels are available in the RTC. The compare values can be set by writing to the RTC compare channel registers RTC_COMPn, and when RTC_CNT is equal to one of these, the respective compare interrupt flag COMPn is set.

If COMP0TOP is set, the compare value set for compare channel 0 is used as a top value for the RTC, and the timer is cleared on a compare match with compare channel 0. If using the COMP0TOP setting, make sure to set this bit prior to or at the same time the EN bit is set. Setting COMP0TOP after the EN bit is set may cause unintended operation (i.e. if CNT > COMP0).

20.3.2.1 LETIMER Triggers

A compare event on either of the compare channels can start the LETIMER. See the LETIMER documentation for more information on this feature.

20.3.2.2 PRS Sources

Both the compare channels of the RTC can be used as PRS sources. They will generate a pulse lasting one RTC clock cycle on a compare match.

20.3.3 Interrupts

The interrupts generated by the RTC are combined into one interrupt vector. If interrupts for the RTC is enabled, an interrupt will be made if one or more of the interrupt flags in RTC_IF and their corresponding bits in RTC_IEN are set. Interrupt events are overflow and compare match on either compare channels. Clearing of an interrupt flag is performed by writing to the corresponding bit in the RTC_IFC register.

20.3.4 Debugrun

By default, the RTC is halted when code execution is halted from the debugger. By setting the DEBUGRUN bit in the RTC_CTRL register, the RTC will continue to run even when the debugger is halted.

20.3.5 Register access

Since this module is a Low Energy Peripheral, and runs off a clock which is asynchronous to the HFCORECLK, special considerations must be taken when accessing registers. Please refer to Section 5.3 (p. 18) for a description on how to perform register accesses to Low Energy Peripherals.

20.4 Register Map

The offset register address is relative to the registers base address.

Offset	Name	Type	Description
0x000	RTC_CTRL	RW	Control Register
0x004	RTC_CNT	R	Counter Value Register
0x008	RTC_COMP0	RW	Compare Value Register 0
0x00C	RTC_COMP1	RW	Compare Value Register 1
0x010	RTC_IF	R	Interrupt Flag Register
0x014	RTC_IFS	W1	Interrupt Flag Set Register
0x018	RTC_IFC	W1	Interrupt Flag Clear Register
0x01C	RTC_IEN	RW	Interrupt Enable Register
0x020	RTC_FREEZE	RW	Freeze Register
0x024	RTC_SYNCBUSY	R	Synchronization Busy Register

20.5 Register Description

20.5.1 RTC_CTRL - Control Register (Async Reg)

For more information about Asynchronous Registers please see Section 5.3 (p. 18) .

Offset	Bit Position																															
0x000	31	30	29	28	27	26	25	24	23	22	21	20	19	18	17	16	15	14	13	12	11	10	9	8	7	6	5	4	3	2	1	0
Reset																											0	0	0			
Access																											RW	RW	RW			
Name																											COMP0TOP	DEBUGRUN	EN			

Bit	Name	Reset	Access	Description
31:3	Reserved	To ensure compatibility with future devices, always write bits to 0. More information in Section 2.1 (p. 3)		
2	COMP0TOP	0	RW	Compare Channel 0 is Top Value When set, the counter is cleared in the clock cycle after a compare match with compare channel 0.
	Value	Mode	Description	
	0	DISABLE	The top value of the RTC is 16777215 (0xFFFFF)	
	1	ENABLE	The top value of the RTC is given by COMP0	
1	DEBUGRUN	0	RW	Debug Mode Run Enable Set this bit to enable the RTC to keep running in debug
	Value	Description		
	0	RTC is frozen in debug mode		
	1	RTC is running in debug mode		
0	EN	0	RW	RTC Enable When this bit is set, the RTC is enabled and counts up. When cleared, the counter register CNT is reset.

20.5.2 RTC_CNT - Counter Value Register

Offset	Bit Position																															
0x004	31	30	29	28	27	26	25	24	23	22	21	20	19	18	17	16	15	14	13	12	11	10	9	8	7	6	5	4	3	2	1	0
Reset																								0x000000								
Access																								R								
Name																								CNT								

Bit	Name	Reset	Access	Description
31:24	Reserved	To ensure compatibility with future devices, always write bits to 0. More information in Section 2.1 (p. 3)		
23:0	CNT	0x000000	R	Counter Value Gives access to the counter value of the RTC.

20.5.3 RTC_COMP0 - Compare Value Register 0 (Async Reg)

For more information about Asynchronous Registers please see Section 5.3 (p. 18) .

Offset	Bit Position																															
0x008	31	30	29	28	27	26	25	24	23	22	21	20	19	18	17	16	15	14	13	12	11	10	9	8	7	6	5	4	3	2	1	0
Reset																								0x000000								
Access																								RW								
Name																								COMP0								

Bit	Name	Reset	Access	Description
31:24	Reserved	To ensure compatibility with future devices, always write bits to 0. More information in Section 2.1 (p. 3)		
23:0	COMP0	0x000000	RW	Compare Value 0 A compare match event occurs when CNT is equal to this value. This event sets the COMP0 interrupt flag, and can be used to start the LETIMER. It is also available as a PRS signal.

20.5.4 RTC_COMP1 - Compare Value Register 1 (Async Reg)

For more information about Asynchronous Registers please see Section 5.3 (p. 18) .

Offset	Bit Position																															
	31	30	29	28	27	26	25	24	23	22	21	20	19	18	17	16	15	14	13	12	11	10	9	8	7	6	5	4	3	2	1	0
0x00C																																
Reset																									0x000000							
Access																									RW							
Name																									COMP1							

Bit	Name	Reset	Access	Description
31:24	Reserved	To ensure compatibility with future devices, always write bits to 0. More information in Section 2.1 (p. 3)		
23:0	COMP1	0x000000	RW	Compare Value 1 A compare match event occurs when CNT is equal to this value. This event sets COMP1 interrupt flag, and can be used to start the LETIMER. It is also available as a PRS signal.

20.5.5 RTC_IF - Interrupt Flag Register

Offset	Bit Position																																
	31	30	29	28	27	26	25	24	23	22	21	20	19	18	17	16	15	14	13	12	11	10	9	8	7	6	5	4	3	2	1	0	
0x010																																	
Reset																																	
Access																									R	0	2	R	0	1	R	0	0
Name																									COMP1		COMP0		OF				

Bit	Name	Reset	Access	Description
31:3	Reserved	To ensure compatibility with future devices, always write bits to 0. More information in Section 2.1 (p. 3)		
2	COMP1	0	R	Compare Match 1 Interrupt Flag Set on a compare match between CNT and COMP1.
1	COMP0	0	R	Compare Match 0 Interrupt Flag Set on a compare match between CNT and COMP0.
0	OF	0	R	Overflow Interrupt Flag Set on a CNT value overflow.

20.5.6 RTC_IFS - Interrupt Flag Set Register

Offset	Bit Position																																
	31	30	29	28	27	26	25	24	23	22	21	20	19	18	17	16	15	14	13	12	11	10	9	8	7	6	5	4	3	2	1	0	
0x014																																	
Reset																																	
Access																									W1	0	2	W1	0	1	W1	0	0
Name																									COMP1		COMP0		OF				

Bit	Name	Reset	Access	Description
31:3	Reserved	To ensure compatibility with future devices, always write bits to 0. More information in Section 2.1 (p. 3)		
2	COMP1	0	W1	Set Compare match 1 Interrupt Flag Write to 1 to set the COMP1 interrupt flag
1	COMP0	0	W1	Set Compare match 0 Interrupt Flag Write to 1 to set the COMP0 interrupt flag
0	OF	0	W1	Set Overflow Interrupt Flag Write to 1 to set the OF interrupt flag

20.5.7 RTC_IFC - Interrupt Flag Clear Register

Offset	Bit Position																															
0x018	31	30	29	28	27	26	25	24	23	22	21	20	19	18	17	16	15	14	13	12	11	10	9	8	7	6	5	4	3	2	1	0
Reset																												0	0	0		
Access																												W1	W1	W1		
Name																												COMP1	COMP0	OF		

Bit	Name	Reset	Access	Description
31:3	Reserved	To ensure compatibility with future devices, always write bits to 0. More information in Section 2.1 (p. 3)		
2	COMP1	0	W1	Clear Compare match 1 Interrupt Flag Write to 1 to clear the COMP1 interrupt flag
1	COMP0	0	W1	Clear Compare match 0 Interrupt Flag Write to 1 to clear the COMP0 interrupt flag
0	OF	0	W1	Clear Overflow Interrupt Flag Write to 1 to clear the OF interrupt flag

20.5.8 RTC_IEN - Interrupt Enable Register

Offset	Bit Position																															
0x01C	31	30	29	28	27	26	25	24	23	22	21	20	19	18	17	16	15	14	13	12	11	10	9	8	7	6	5	4	3	2	1	0
Reset																												0	0	0		
Access																												RW	RW	RW		
Name																												COMP1	COMP0	OF		

Bit	Name	Reset	Access	Description
31:3	Reserved	To ensure compatibility with future devices, always write bits to 0. More information in Section 2.1 (p. 3)		
2	COMP1	0	RW	Compare Match 1 Interrupt Enable Enable interrupt on compare match 1
1	COMP0	0	RW	Compare Match 0 Interrupt Enable Enable interrupt on compare match 0
0	OF	0	RW	Overflow Interrupt Enable

Bit	Name	Reset	Access	Description
	Enable interrupt on overflow			

20.5.9 RTC_FREEZE - Freeze Register

Offset	Bit Position																															
0x020	31	30	29	28	27	26	25	24	23	22	21	20	19	18	17	16	15	14	13	12	11	10	9	8	7	6	5	4	3	2	1	0
Reset																																
Access																																
Name																																
	REGFREEZE																															

Bit	Name	Reset	Access	Description
31:1	<i>Reserved</i>			<i>To ensure compatibility with future devices, always write bits to 0. More information in Section 2.1 (p. 3)</i>

0	REGFREEZE	0	RW	Register Update Freeze When set, the update of the RTC is postponed until this bit is cleared. Use this bit to update several registers simultaneously.
	Value	Mode	Description	
	0	UPDATE	Each write access to an RTC register is updated into the Low Frequency domain as soon as possible.	
	1	FREEZE	The RTC is not updated with the new written value until the freeze bit is cleared.	

20.5.10 RTC_SYNCBUSY - Synchronization Busy Register

Offset	Bit Position																															
0x024	31	30	29	28	27	26	25	24	23	22	21	20	19	18	17	16	15	14	13	12	11	10	9	8	7	6	5	4	3	2	1	0
Reset																																
Access																																
Name																																
	COMP1 COMP0 CTRL																															

Bit	Name	Reset	Access	Description
31:3	<i>Reserved</i>			<i>To ensure compatibility with future devices, always write bits to 0. More information in Section 2.1 (p. 3)</i>
2	COMP1	0	R	RTC_COMP1 Register Busy Set when the value written to RTC_COMP1 is being synchronized.
1	COMP0	0	R	RTC_COMP0 Register Busy Set when the value written to RTC_COMP0 is being synchronized.
0	CTRL	0	R	RTC_CTRL Register Busy Set when the value written to RTC_CTRL is being synchronized.

21 LETIMER - Low Energy Timer

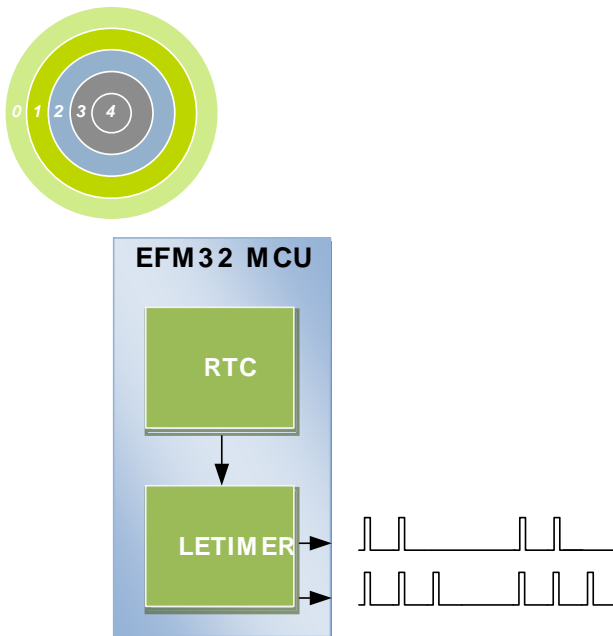

Quick Facts

What?

The LETIMER is a down-counter that can keep track of time and output configurable waveforms. Running on a 32.768 kHz clock the LETIMER is available even in EM2 with sub μ A current consumption.

Why?

The LETIMER can be used to provide repeatable waveforms to external components while remaining in EM2. It is well suited for e.g. metering systems or to provide more compare values than available in the RTC.

How?

With buffered repeat and top value registers, the LETIMER can provide glitch-free waveforms at frequencies up to 16 kHz. It is tightly coupled to the RTC, which allows advanced time-keeping and wake-up functions in EM2.

21.1 Introduction

The unique LETIMER[™], the Low Energy Timer, is a 16-bit timer that is available in energy mode EM2 in addition to EM1 and EM0. Because of this, it can be used for timing and output generation when most of the device is powered down, allowing simple tasks to be performed while the power consumption of the system is kept at an absolute minimum.

The LETIMER can be used to output a variety of waveforms with minimal software intervention. It is also connected to the Real Time Counter (RTC), and can be configured to start counting on compare matches from the RTC.

21.2 Features

- 16-bit down count timer
- 2 Compare match registers
- Compare register 0 can be top timer top value
- Compare registers can be double buffered
- Double buffered 8-bit Repeat Register
- Same clock source as the Real Time Counter
- LETIMER can be triggered (started) by an RTC event or by software
- 2 output pins can optionally be configured to provide different waveforms on timer underflow:
 - Toggle output pin
 - Apply a positive pulse (pulse width of one $LFACTK_{LETIMER}$ period)
 - PWM
- Interrupt on:
 - Compare matches
 - Timer underflow

- Repeat done
- Optionally runs during debug

21.3 Functional Description

An overview of the LETIMER module is shown in Figure 21.1 (p. 288) . The LETIMER is a 16-bit down-counter with two compare registers, LETIMERn_COMP0 and LETIMERn_COMP1. The LETIMERn_COMP0 register can optionally act as a top value for the counter. The repeat counter LETIMERn_REP0 allows the timer to count a specified number of times before it stops. Both the LETIMERn_COMP0 and LETIMERn_REP0 registers can be double buffered by the LETIMERn_COMP1 and LETIMERn_REP1 registers to allow continuous operation. The timer can generate a single pin output, or two linked outputs.

Figure 21.1. LETIMER Overview

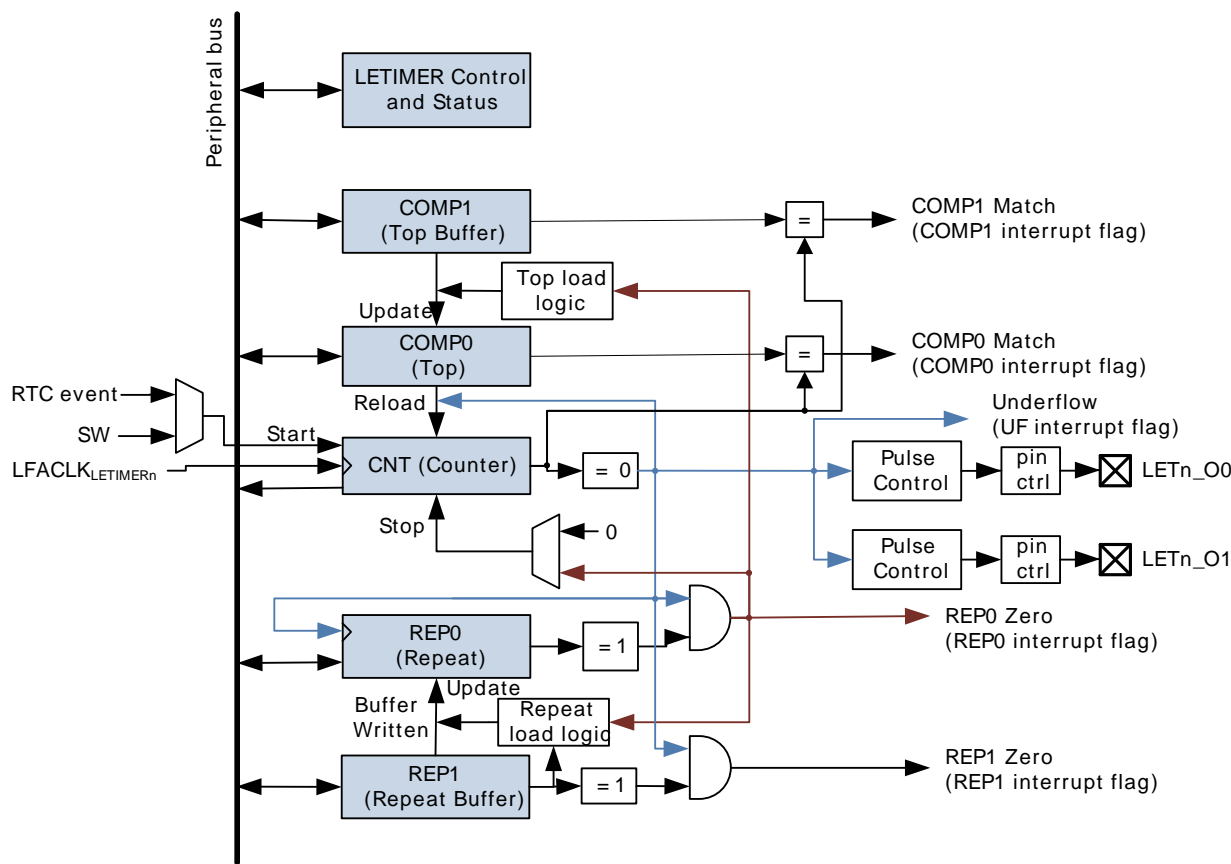

21.3.1 Timer

The timer is started by setting command bit START in LETIMERn_CMD, and stopped by setting the STOP command bit in the same register. RUNNING in LETIMERn_STATUS is set as long as the timer is running. The timer can also be started on external signals, such as a compare match from the Real Time Counter. If START and STOP are set at the same time, STOP has priority, and the timer will be stopped.

The timer value can be read using the LETIMERn_CNT register. The value cannot be written, but it can be cleared by setting the CLEAR command bit in LETIMERn_CMD. If the CLEAR and START commands are issued at the same time, the timer will be cleared, then start counting at the top value.

21.3.2 Compare Registers

The LETIMER has two compare match registers, LETIMERn_COMP0 and LETIMERn_COMP1. Each of these compare registers are capable of generating an interrupt when the counter value

LETIMERn_CNT becomes equal to their value. When LETIMERn_CNT becomes equal to the value of LETIMERn_COMP0, the interrupt flag COMP0 in LETIMERn_IF is set, and when LETIMERn_CNT becomes equal to the value of LETIMERn_COMP1, the interrupt flag COMP1 in LETIMERn_IF is set.

21.3.3 Top Value

If COMP0TOP in LETIMERn_CTRL is set, the value of LETIMERn_COMP0 acts as the top value of the timer, and LETIMERn_COMP0 is loaded into LETIMERn_CNT on timer underflow. Else, the timer wraps around to 0xFFFF. The underflow interrupt flag UF in LETIMERn_IF is set when the timer reaches zero.

21.3.3.1 Buffered Top Value

If BUFTOP in LETIMERn_CTRL is set, the value of LETIMERn_COMP0 is buffered by LETIMERn_COMP1. In this mode, the value of LETIMERn_COMP1 is loaded into LETIMERn_COMP0 every time LETIMERn_REP0 is about to decrement to 0. This can for instance be used in conjunction with the buffered repeat mode to generate continually changing output waveforms.

Write operations to LETIMERn_COMP0 have priority over buffer loads.

21.3.3.2 Repeat Modes

By default, the timer wraps around to the top value or 0xFFFF on each underflow, and continues counting. The repeat counters can be used to get more control of the operation of the timer, including defining the number of times the counter should wrap around. Four different repeat modes are available, see Table 21.1 (p. 289) .

Table 21.1. LETIMER Repeat Modes

REPMODE	Mode	Description
00	Free	The timer runs until it is stopped
01	One-shot	The timer runs as long as LETIMERn_REP0 != 0. LETIMERn_REP0 is decremented at each timer underflow.
10	Buffered	The timer runs as long as LETIMERn_REP0 != 0. LETIMERn_REP0 is decremented on each timer underflow. If LETIMERn_REP1 has been written, it is loaded into LETIMERn_REP0 when LETIMERn_REP0 is about to be decremented to 0.
11	Double	The timer runs as long as LETIMERn_REP0 != 0 or LETIMERn_REP1 != 0. Both LETIMERn_REP0 and LETIMERn_REP1 are decremented at each timer underflow.

The interrupt flags REP0 and REP1 in LETIMERn_IF are set whenever LETIMERn_REP0 or LETIMERn_REP1 are decremented to 0 respectively. REP0 is also set when the value of LETIMERn_REP1 is loaded into LETIMERn_REP0 in buffered mode.

21.3.3.2.1 Free Mode

In the free running mode, the LETIMER acts as a regular timer, and the repeat counter is disabled. When started, the timer runs until it is stopped using the STOP command bit in LETIMERn_CMD. A state machine for this mode is shown in Figure 21.2 (p. 290) .

Figure 21.2. LETIMER State Machine for Free-running Mode

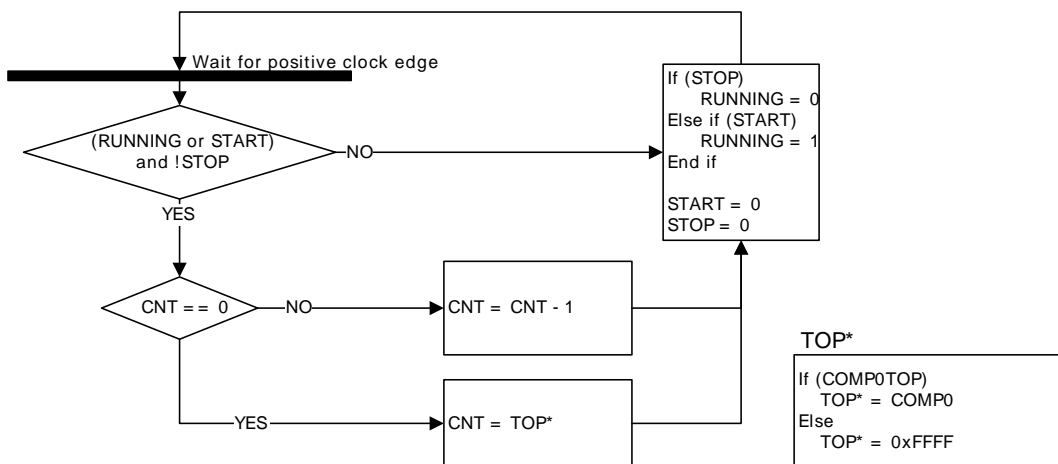

Note that the CLEAR command bit in LETIMERn_CMD always has priority over other changes to LETIMERn_CNT. When the clear command is used, LETIMERn_CNT is set to 0 and an underflow event will not be generated when LETIMERn_CNT wraps around to the top value or 0xFFFF. Since no underflow event is generated, no output action is performed. LETIMERn_REP0, LETIMERn_REP1, LETIMERn_COMP0 and LETIMERn_COMP1 are also left untouched.

21.3.3.2.2 One-shot Mode

The one-shot repeat mode is the most basic repeat mode. In this mode, the repeat register LETIMERn_REP0 is decremented every time the timer underflows, and the timer stops when LETIMERn_REP0 goes from 1 to 0. In this mode, the timer counts down LETIMERn_REP0 times, i.e. the timer underflows LETIMERn_REP0 times.

Note

Note that write operations to LETIMERn_REP0 have priority over the decrementation operation. So if LETIMERn_REP0 is assigned a new value in the same cycle it was supposed to be decremented, it is assigned the new value instead of being decremented.

LETIMERn_REP0 can be written while the timer is running to allow the timer to run for longer periods at a time without stopping. Figure 21.3 (p. 291) .

Figure 21.3. LETIMER One-shot Repeat State Machine

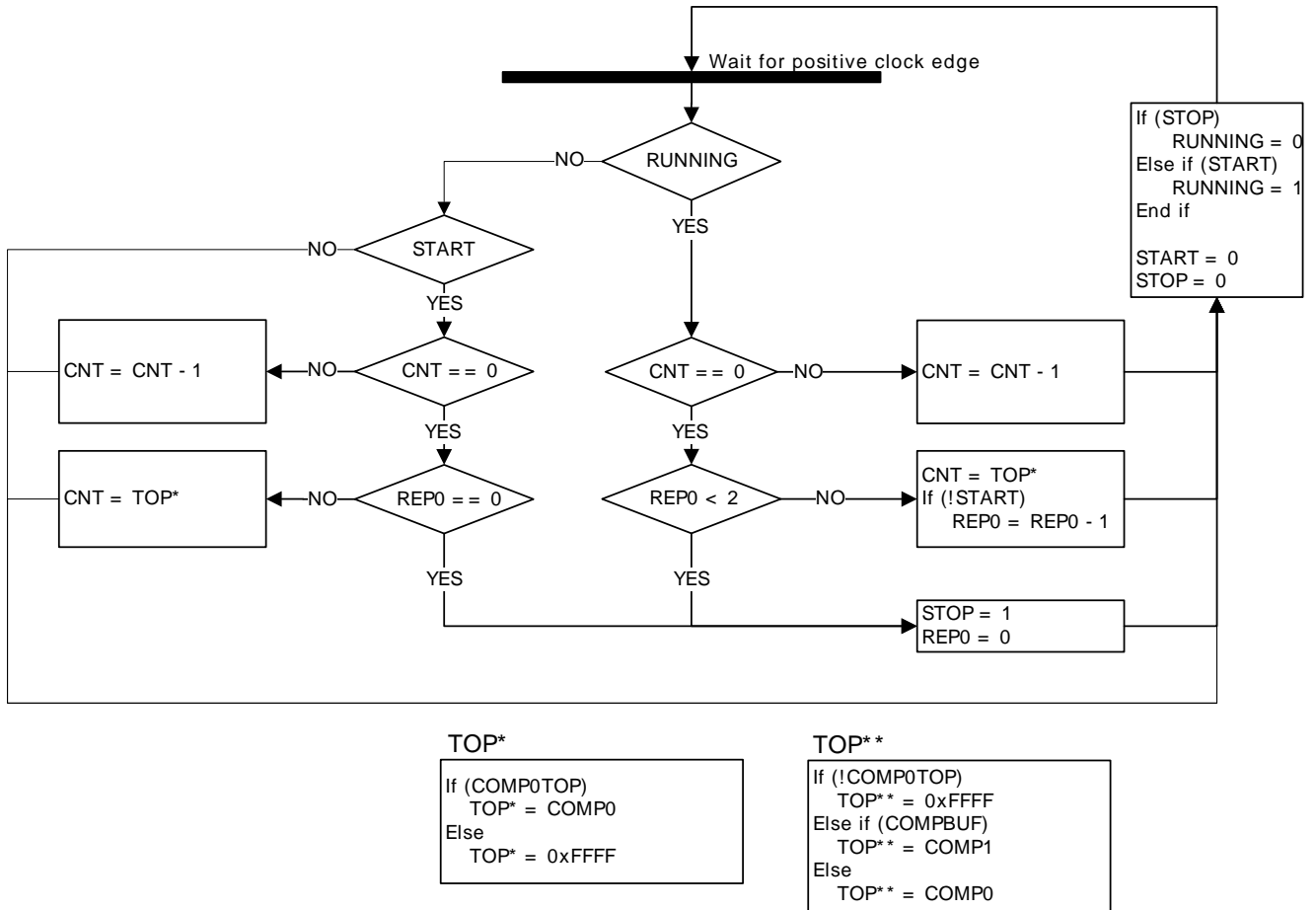

21.3.3.2.3 Buffered Mode

The Buffered repeat mode allows buffered timer operation. When started, the timer runs LETIMERn_REP0 number of times. If LETIMERn_REP1 has been written since the last time it was used and it is nonzero, LETIMERn_REP1 is then loaded into LETIMERn_REP0, and counting continues the new number of times. The timer keeps going as long as LETIMERn_REP1 is updated with a nonzero value before LETIMERn_REP0 is finished counting down.

If the timer is started when both LETIMERn_CNT and LETIMERn_REP0 are zero but LETIMERn_REP1 is non-zero, LETIMERn_REP1 is loaded into LETIMERn_REP0, and the counter counts the loaded number of times. The state machine for the one-shot repeat mode is shown in Figure 21.3 (p. 291) .

Used in conjunction with a buffered top value, enabled by setting BUFTOP in LETIMERn_CTRL, the buffered mode allows buffered values of both the top and repeat values of the timer, and the timer can for instance be set to run 4 times with period 7 (top value 6), 6 times with period 200, then 3 times with period 50.

A state machine for the buffered repeat mode is shown in Figure 21.4 (p. 292) . REP1_{USED} shown in the state machine is an internal variable that keeps track of whether the value in LETIMERn_REP1 has been loaded into LETIMERn_REP0 or not. The purpose of this is that a value written to LETIMERn_REP1 should only be counted once. REP1_{USED} is cleared whenever LETIMERn_REP1 is written.

Figure 21.4. LETIMER Buffered Repeat State Machine

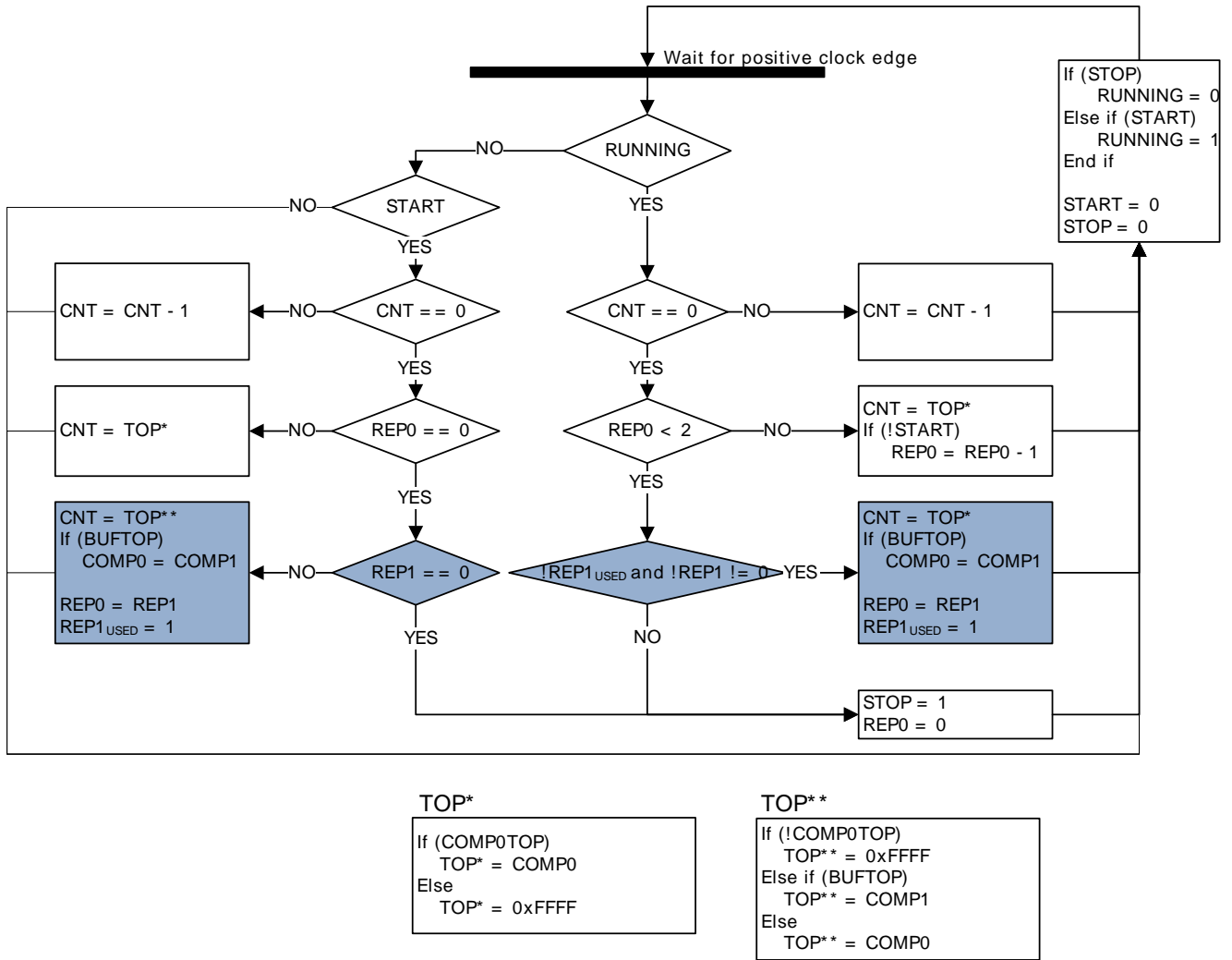

21.3.3.2.4 Double Mode

The Double repeat mode works much like the one-shot repeat mode. The difference is that, where the one-shot mode counts as long as LETIMERN_REP0 is larger than 0, the double mode counts as long as either LETIMERN_REP0 or LETIMERN_REP1 is larger than 0. As an example, say LETIMERN_REP0 is 3 and LETIMERN_REP1 is 10 when the timer is started. If no further interaction is done with the timer, LETIMERN_REP0 will now be decremented 3 times, and LETIMERN_REP1 will be decremented 10 times. The timer counts a total of 10 times, and LETIMERN_REP0 is 0 after the first three timer underflows and stays at 0. LETIMERN_REP0 and LETIMERN_REP1 can be written at any time. After a write to either of these, the timer is guaranteed to underflow at least the written number of times if the timer is running. Use the Double repeat mode to generate output on both the LETIMER outputs at the same time. The state machine for this repeat mode can be seen in Figure 21.5 (p. 293).

Figure 21.5. LETIMER Double Repeat State Machine

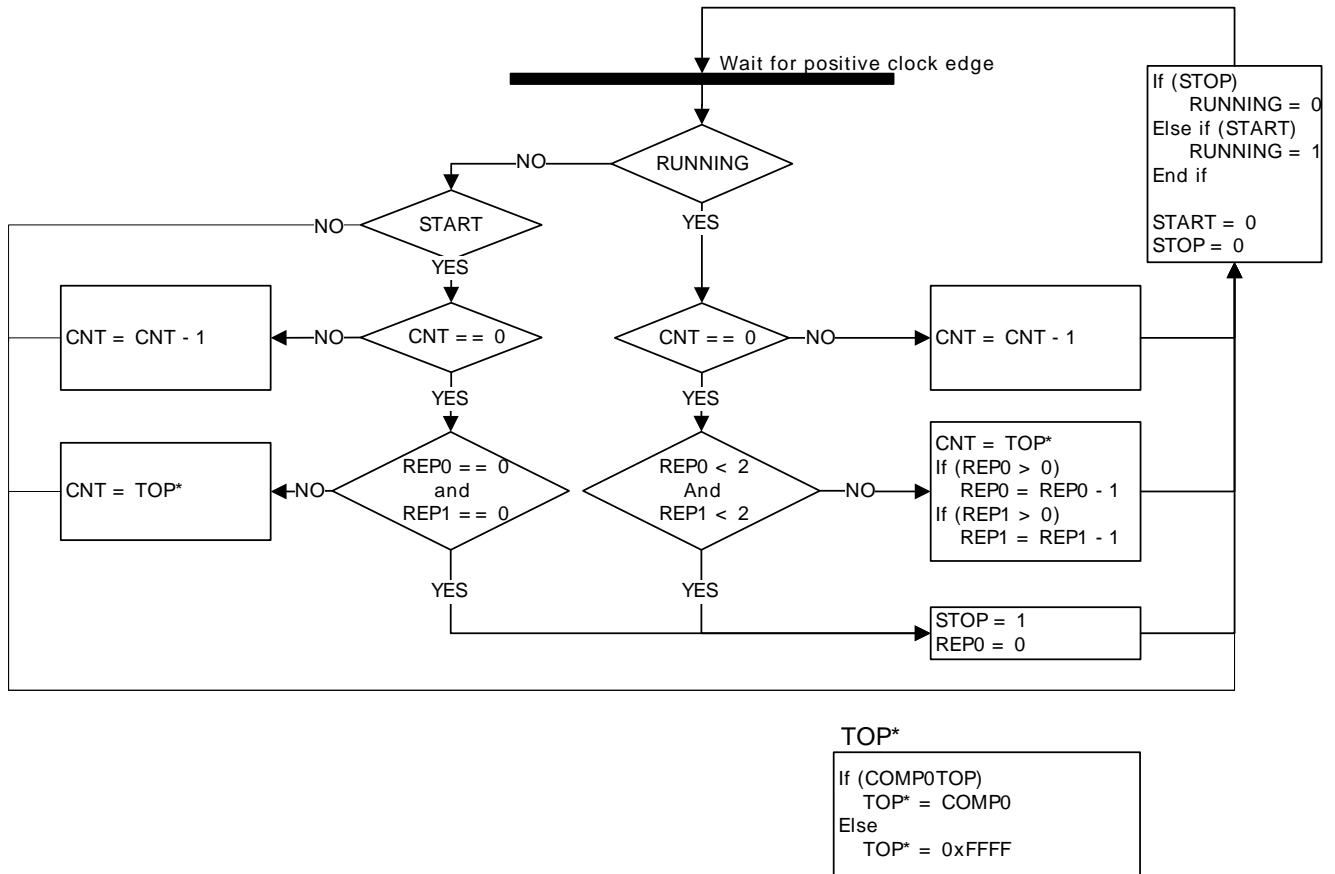

21.3.3.3 Clock Source

The LETIMER clock source and its prescaler value are defined in the Clock Management Unit (CMU). The $f_{LFACKL_LETIMERn}$ has a frequency given by Equation 21.1 (p. 293) .

LETIMER Clock Frequency

$$f_{LFACKL_LETIMERn} = 32.768 / 2^{LETIMERn} \tag{21.1}$$

where the exponent LETIMERn is a 4 bit value in the CMU_LFAPRESC0 register.

To use this module, the LE interface clock must be enabled in CMU_HFCORECLKEN0, in addition to the module clock.

21.3.3.4 RTC Trigger

The LETIMER can be configured to start on compare match events from the Real Time Counter (RTC). If RTCC0TEN in LETIMERn_CTRL is set, the LETIMER will start on a compare match on RTC compare channel 0. In the same way, RTCC1TEN in LETIMERn_CTRL enables the LETIMER to start on a compare match with RTC compare channel 1.

Note

The LETIMER can only use compare match events from the RTC if the LETIMER runs at a higher than or equal frequency than the RTC. Also, if the LETIMER runs at twice the frequency of the RTC, a compare match event in the RTC will trigger the LETIMER twice. Four times the frequency gives four consecutive triggers, etc. The LETIMER will only continue running if triggered while it is running, so the multiple-triggering will only have an effect if you try to disable the RTC when it is being triggered.

21.3.3.5 Debug

If DEBUGRUN in LETIMERn_CTRL is cleared, the LETIMER automatically stops counting when the CPU is halted during a debug session, and resumes operation when the CPU continues. Because of synchronization, the LETIMER is halted two clock cycles after the CPU is halted, and continues running two clock cycles after the CPU continues. RUNNING in LETIMERn_STATUS is not cleared when the LETIMER stops because of a debug-session.

Set DEBUGRUN in LETIMERn_CTRL to allow the LETIMER to continue counting even when the CPU is halted in debug mode.

21.3.4 Underflow Output Action

For each of the repeat registers, an underflow output action can be set. The configured output action is performed every time the counter underflows while the respective repeat register is nonzero. In PWM mode, the output is similarly only changed on COMP1 match if the repeat register is nonzero. As an example, the timer will perform 7 output actions if LETIMERn_REP0 is set to 7 when starting the timer in one-shot mode and leaving it untouched for a while.

The output actions can be set by configuring UFOA0 and UFOA1 in LETIMERn_CTRL. UFOA0 defines the action on output 0, and is connected to LETIMERn_REP0, while UFOA1 defines the action on output 1 and is connected to LETIMERn_REP1. The possible actions are defined in Table 21.2 (p. 294) .

Table 21.2. LETIMER Underflow Output Actions

UFOA0/UFOA1	Mode	Description
00	Idle	The output is held at its idle value
01	Toggle	The output is toggled on LETIMERn_CNT underflow if LETIMERn_REPx is nonzero
10	Pulse	The output is held active for one clock cycle on LETIMERn_CNT underflow if LETIMERn_REPx is nonzero. It then returns to its idle value
11	PWM	The output is set idle on LETIMERn_CNT underflow and active on compare match with LETIMERn_COMP1 if LETIMERn_REPx is nonzero.

Note

For the Pulse and PWM modes, the outputs will return to their idle states regardless of the state of the corresponding LETIMERn_REPx registers. They will only be set active if the LETIMERn_REPx registers are nonzero however.

The polarity of the outputs can be set individually by configuring OPOL0 and OPOL1 in LETIMERn_CTRL. When these are cleared, their respective outputs have a low idle value and a high active value. When they are set, the idle value is high, and the active value is low.

When using the toggle action, the outputs can be driven to their idle values by setting their respective CTO0/CTO1 command bits in LETIMERn_CTRL. This can be used to put the output in a well-defined state before beginning to generate toggle output, which may be important in some applications. The command bit can also be used while the timer is running.

Some simple waveforms generated with the different output modes are shown in Figure 21.6 (p. 295) . For the example, REPMODE in LETIMERn_CTRL has been cleared, COMP0TOP also in LETIMERn_CTRL has been set and LETIMERn_COMP0 has been written to 3. As seen in the figure, LETIMERn_COMP0 now decides the length of the signal periods. For the toggle mode, the period of the output signal is 2(LETIMERn_COMP0 + 1), and for the pulse modes, the periods of the output signals

are LETIMERn_COMP0+1. Note that the pulse outputs are delayed by one period relative to the toggle output. The pulses come at the end of their periods.

Figure 21.6. LETIMER Simple Waveforms Output

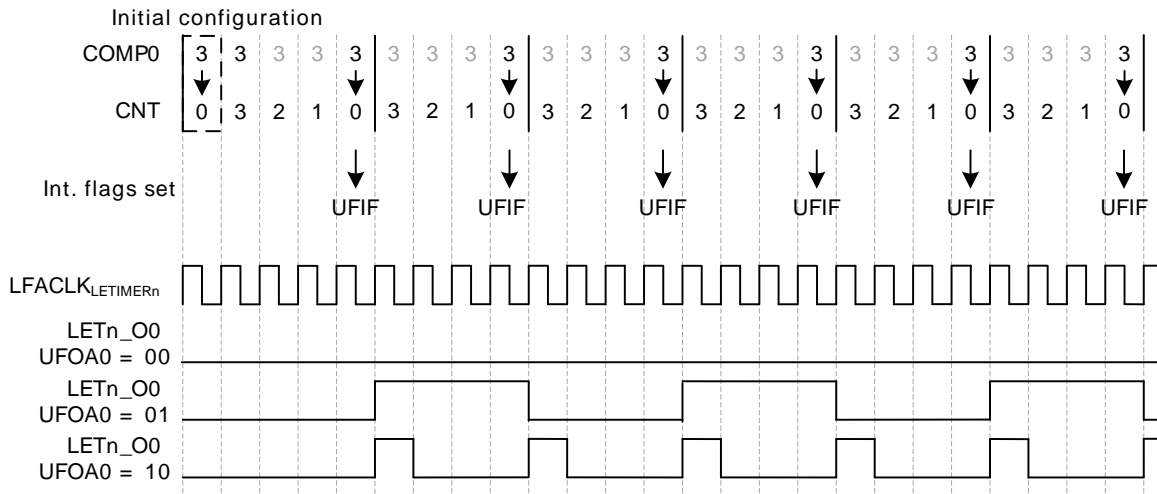

For the example in Figure 21.7 (p. 295), the One-shot repeat mode has been selected, and LETIMERn_REP0 has been written to 3. The resulting behavior is pretty similar to that shown in Figure 6, but in this case, the timer stops after counting to zero LETIMERn_REP0 times. By using LETIMERn_REP0 the user has full control of the number of pulses/toggles generated on the output.

Figure 21.7. LETIMER Repeated Counting

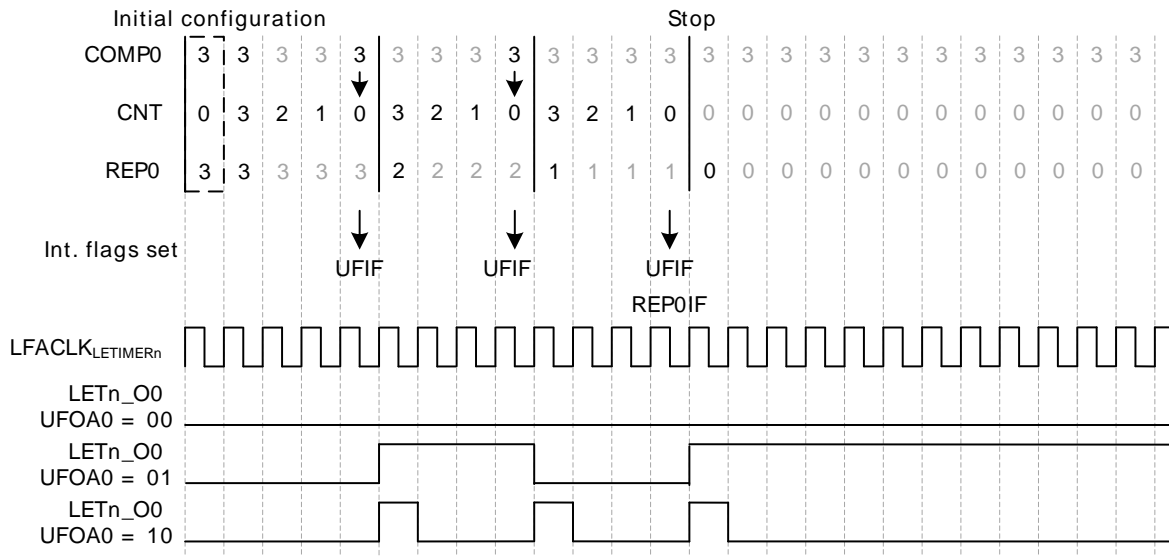

Using the Double repeat mode, output can be generated on both the LETIMER outputs. Figure 21.8 (p. 295) shows an example of this. UFOA0 and UFOA1 in LETIMERn_CTRL are configured for pulse output and the outputs are configured for low idle polarity. As seen in the figure, the number written to the repeat registers determine the number of pulses generated on each of the outputs.

Figure 21.8. LETIMER Dual Output

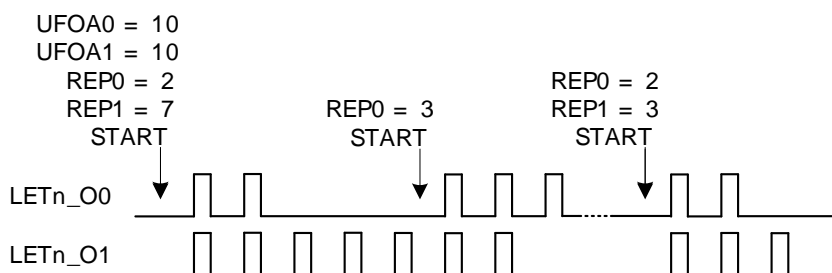

21.3.5 Examples

This section presents a couple of usage examples for the LETIMER.

21.3.5.1 Triggered Output Generation

Example 21.1. LETIMER Triggered Output Generation

If both LETIMERn_CNT and LETIMERn_REP0 are 0 in buffered mode, and COMP0TOP and BUFTOP in LETIMERn_CTRL are set, the values of LETIMERn_COMP1 and LETIMERn_REP1 are loaded into LETIMERn_CNT and LETIMERn_REP0 respectively when the timer is started. If no additional writes to LETIMERn_REP1 are done before the timer stops, LETIMERn_REP1 determines the number of pulses/toggles generated on the output, and LETIMERn_COMP1 determines the period lengths.

As the RTC can be used to start the LETIMER, the RTC and LETIMER can thus be combined to generate specific pulse-trains at given intervals. Software can update LETIMERn_COMP1 and LETIMERn_REP1 to change the number of pulses and pulse-period in each train, but if changes are not required, software does not have to update the registers between each pulse train.

For the example in Figure 21.9 (p. 296), the initial values cause the LETIMER to generate two pulses with 3 cycle periods, or a single pulse 3 cycles wide every time the LETIMER is started. After the output has been generated, the LETIMER stops, and is ready to be triggered again.

Figure 21.9. LETIMER Triggered Operation

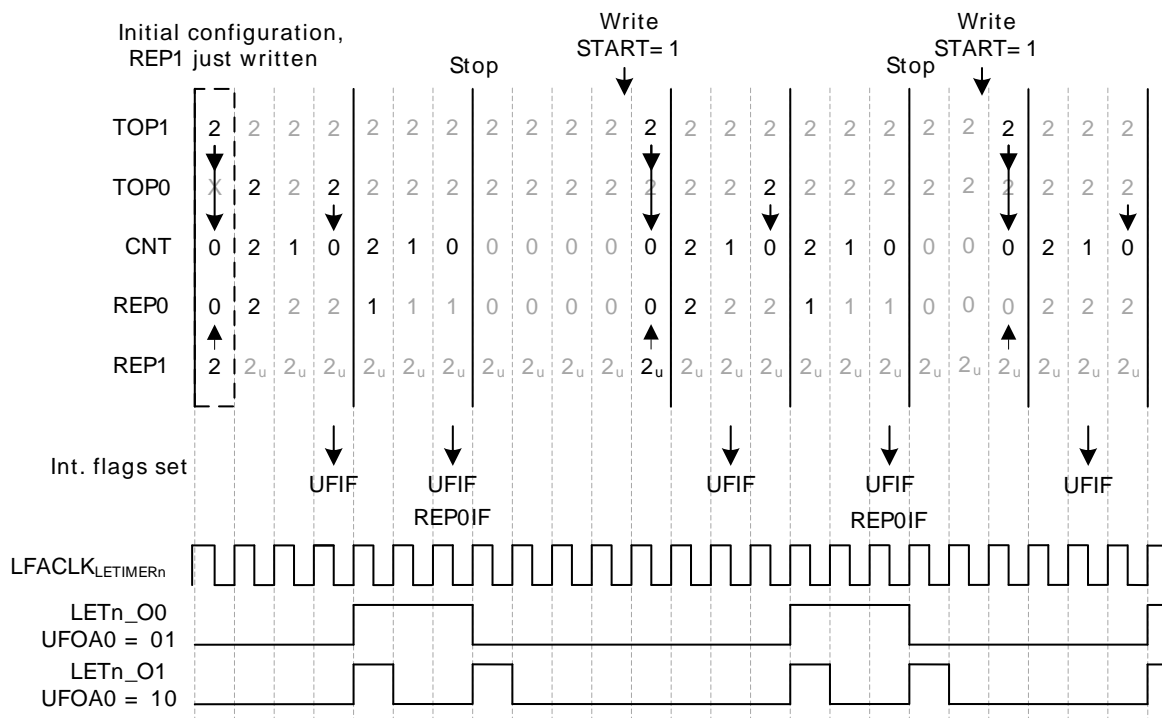

21.3.5.2 Continuous Output Generation

Example 21.2. LETIMER Continuous Output Generation

In some scenarios, it might be desired to make LETIMER generate a continuous waveform. Very simple constant waveforms can be generated without the repeat counter as shown in Figure 21.6 (p. 295), but to generate changing waveforms, using the repeat counter and buffer registers can prove advantageous.

For the example in Figure 21.10 (p. 297), the goal is to produce a pulse train consisting of 3 sequences with the following properties:

- 3 pulses with periods of 3 cycles
- 4 pulses with periods of 2 cycles
- 2 pulses with periods of 3 cycles

Figure 21.10. LETIMER Continuous Operation

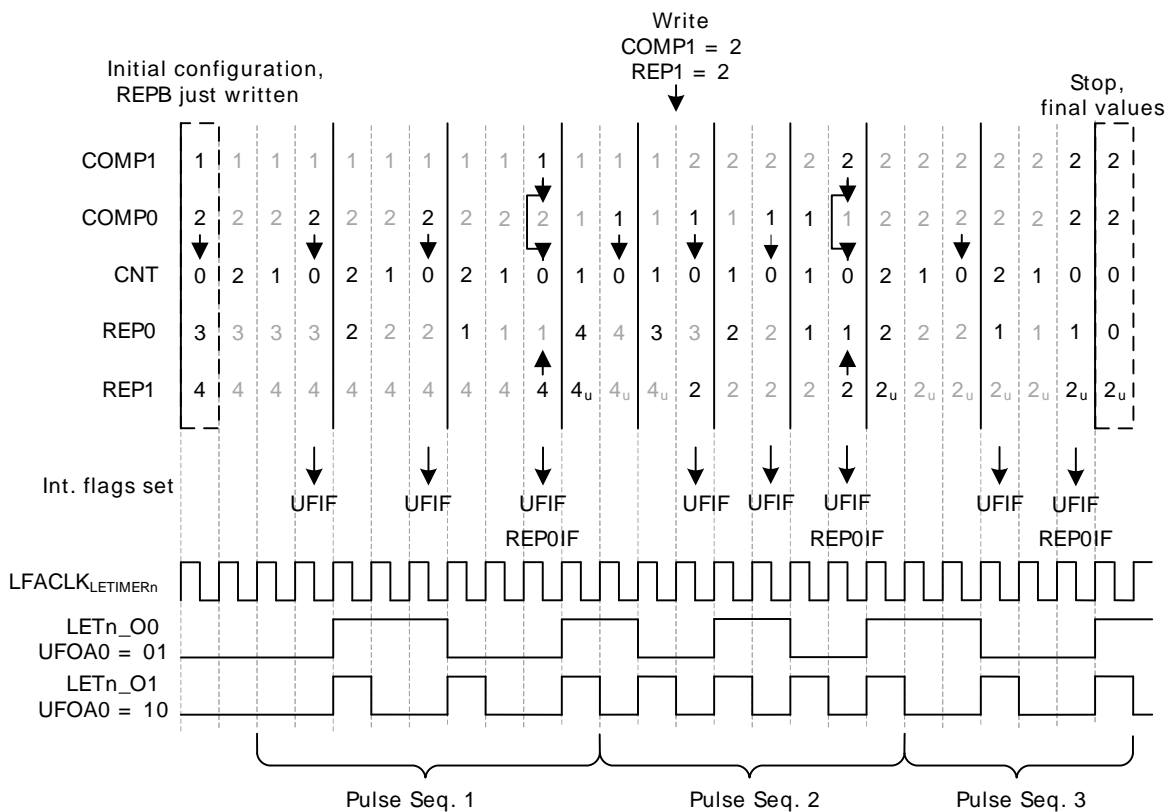

The first two sequences are loaded into the LETIMER before the timer is started. LETIMERn_COMP0 is set to 2 (cycles – 1), and LETIMERn_REP0 is set to 3 for the first sequence, and the second sequence is loaded into the buffer registers, i.e. COMP1 is set to 1 and LETIMERn_REP1 is set to 4.

The LETIMER is set to trigger an interrupt when LETIMERn_REP0 is done by setting REP0 in LETIMERn_IEN. This interrupt is a good place to update the values of the buffers. Last but not least REPMODE in LETIMERn_CTRL is set to buffered mode, and the timer is started.

In the interrupt routine the buffers are updated with the values for the third sequence. If this had not been done, the timer would have stopped after the second sequence.

The final result is shown in Figure 21.10 (p. 297). The pulse output is grouped to show which sequence generated which output. Toggle output is also shown in the figure. Note that the toggle output is not aligned with the pulse outputs.

Note

Multiple LETIMER cycles are required to write a value to the LETIMER registers. The example in Figure 21.10 (p. 297) assumes that writes are done in advance so they arrive in the LETIMER as described in the figure.

Figure 21.11 (p. 298) shows an example where the LETIMER is started while LETIMERn_CNT is nonzero. In this case the length of the first repetition is given by the value in LETIMERn_CNT.

Figure 21.11. LETIMER LETIMERn_CNT Not Initialized to 0

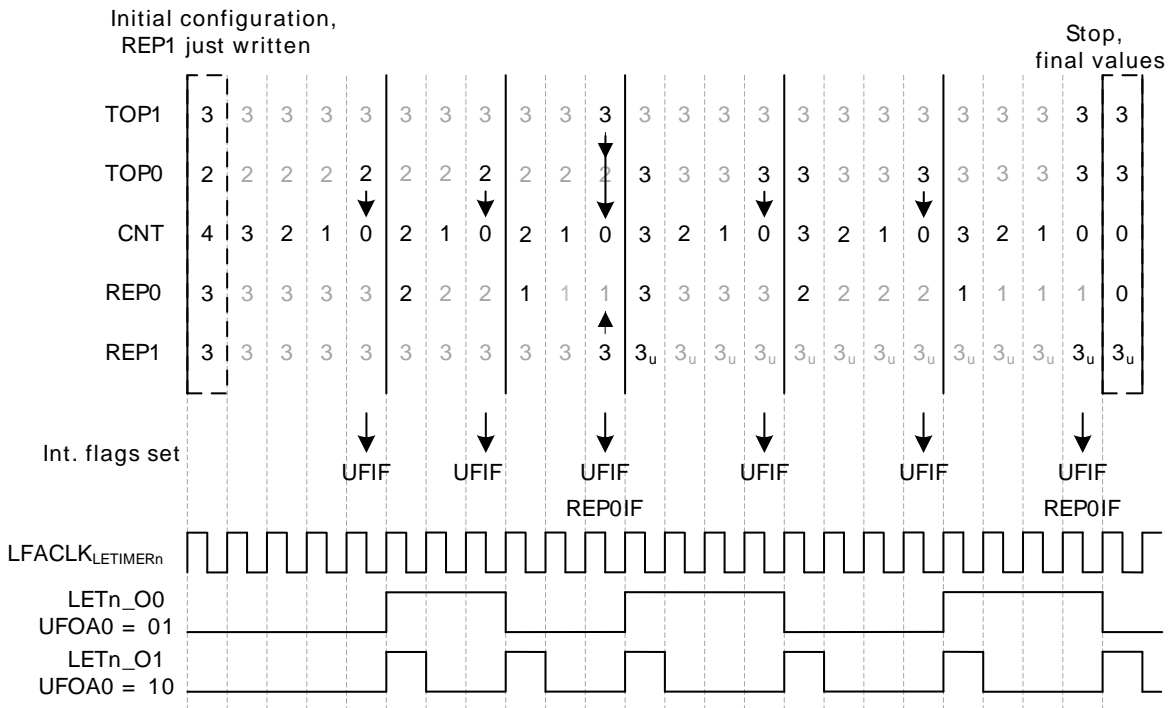

21.3.5.3 PWM Output

Example 21.3. LETIMER PWM Output

There are several ways of generating PWM output with the LETIMER, but the most straight-forward way is using the PWM output mode. This mode is enabled by setting UFOA0 or OFUA1 in LETIMERn_CTRL to 3. In PWM mode, the output is set idle on timer underflow, and active on LETIMERn_COMP1 match, so if for instance COMP0TOP = 1 and OPOL0 = 0 in LETIMERn_CTRL, LETIMERn_COMP0 determines the PWM period, and LETIMERn_LETIMERn_COMP1 determines the active period.

The PWM period in PWM mode is LETIMERn_COMP0 + 1. There is no special handling of the case where LETIMERn_COMP1 > LETIMERn_COMP0, so if LETIMERn_COMP1 > LETIMERn_COMP0, the PWM output is given by the idle output value. This means that for OPOLx = 0 in LETIMERn_CTRL, the PWM output will always be 0 for at least one clock cycle, and for OPOLx = 1 in LETIMERn_CTRL, the PWM output will always be 1 for at least one clock cycle.

To generate a PWM signal using the full PWM range, invert OPOLx when LETIMERn_COMP1 is set to a value larger than LETIMERn_COMP0.

21.3.5.4 Interrupts

Example 21.4. LETIMER PWM Output

The interrupts generated by the LETIMER are combined into one interrupt vector. If the interrupt for the LETIMER is enabled, an interrupt will be made if one or more of the interrupt flags in LETIMERn_IF and their corresponding bits in LETIMER_IEN are set.

21.3.6 Register access

Since this module is a Low Energy Peripheral, and runs off a clock which is asynchronous to the HFCORECLK, special considerations must be taken when accessing registers. Please refer to Section 5.3 (p. 18) for a description on how to perform register accesses to Low Energy Peripherals.

21.4 Register Map

The offset register address is relative to the registers base address.

Offset	Name	Type	Description
0x000	LETIMERn_CTRL	RW	Control Register
0x004	LETIMERn_CMD	W1	Command Register
0x008	LETIMERn_STATUS	R	Status Register
0x00C	LETIMERn_CNT	R	Counter Value Register
0x010	LETIMERn_COMP0	RW	Compare Value Register 0
0x014	LETIMERn_COMP1	RW	Compare Value Register 1
0x018	LETIMERn_REP0	RW	Repeat Counter Register 0
0x01C	LETIMERn_REP1	RW	Repeat Counter Register 1
0x020	LETIMERn_IF	R	Interrupt Flag Register
0x024	LETIMERn_IFS	W1	Interrupt Flag Set Register
0x028	LETIMERn_IFC	W1	Interrupt Flag Clear Register
0x02C	LETIMERn_IEN	RW	Interrupt Enable Register
0x030	LETIMERn_FREEZE	RW	Freeze Register
0x034	LETIMERn_SYNCBUSY	R	Synchronization Busy Register
0x040	LETIMERn_ROUTE	RW	I/O Routing Register

21.5 Register Description

21.5.1 LETIMERn_CTRL - Control Register (Async Reg)

For more information about Asynchronous Registers please see Section 5.3 (p. 18) .

Offset	Bit Position																																													
	31	30	29	28	27	26	25	24	23	22	21	20	19	18	17	16	15	14	13	12	11	10	9	8	7	6	5	4	3	2	1	0														
0x000																	0	0	0	0	0	0	0	0x0	0x0	0x0																				
Reset																																														
Access																	RW	RW	RW	RW	RW	RW	RW	RW	RW	RW	RW	RW	RW	RW	RW	RW	RW	RW	RW	RW										
Name																	DEBUGRUN	RTCC1TEN	RTCC0TEN	COMP0TOP	BUFTOP	OPOL1	OPOL0	UFOA1	UFOA0	REPMODE																				

Bit	Name	Reset	Access	Description						
31:13	Reserved	To ensure compatibility with future devices, always write bits to 0. More information in Section 2.1 (p. 3)								
12	DEBUGRUN	0	RW	Debug Mode Run Enable Set to keep the LETIMER running in debug mode. <table border="1"> <thead> <tr> <th>Value</th> <th>Description</th> </tr> </thead> <tbody> <tr> <td>0</td> <td>LETIMER is frozen in debug mode</td> </tr> <tr> <td>1</td> <td>LETIMER is running in debug mode</td> </tr> </tbody> </table>	Value	Description	0	LETIMER is frozen in debug mode	1	LETIMER is running in debug mode
Value	Description									
0	LETIMER is frozen in debug mode									
1	LETIMER is running in debug mode									
11	RTCC1TEN	0	RW	RTC Compare 1 Trigger Enable Allows the LETIMER to be started on a compare match on RTC compare channel 1. <table border="1"> <thead> <tr> <th>Value</th> <th>Description</th> </tr> </thead> <tbody> <tr> <td>0</td> <td>LETIMER is not affected by RTC compare channel 1</td> </tr> <tr> <td>1</td> <td>A compare match on RTC compare channel 1 starts the LETIMER if the LETIMER is not already started</td> </tr> </tbody> </table>	Value	Description	0	LETIMER is not affected by RTC compare channel 1	1	A compare match on RTC compare channel 1 starts the LETIMER if the LETIMER is not already started
Value	Description									
0	LETIMER is not affected by RTC compare channel 1									
1	A compare match on RTC compare channel 1 starts the LETIMER if the LETIMER is not already started									

Bit	Name	Reset	Access	Description															
10	RTCC0TEN	0	RW	RTC Compare 0 Trigger Enable Allows the LETIMER to be started on a compare match on RTC compare channel 0. <table border="1"> <thead> <tr> <th>Value</th> <th>Description</th> </tr> </thead> <tbody> <tr> <td>0</td> <td>LETIMER is not affected by RTC compare channel 0</td> </tr> <tr> <td>1</td> <td>A compare match on RTC compare channel 0 starts the LETIMER if the LETIMER is not already started</td> </tr> </tbody> </table>	Value	Description	0	LETIMER is not affected by RTC compare channel 0	1	A compare match on RTC compare channel 0 starts the LETIMER if the LETIMER is not already started									
Value	Description																		
0	LETIMER is not affected by RTC compare channel 0																		
1	A compare match on RTC compare channel 0 starts the LETIMER if the LETIMER is not already started																		
9	COMP0TOP	0	RW	Compare Value 0 Is Top Value When set, the counter is cleared in the clock cycle after a compare match with compare channel 0. <table border="1"> <thead> <tr> <th>Value</th> <th>Description</th> </tr> </thead> <tbody> <tr> <td>0</td> <td>The top value of the LETIMER is 65535 (0xFFFF)</td> </tr> <tr> <td>1</td> <td>The top value of the LETIMER is given by COMP0</td> </tr> </tbody> </table>	Value	Description	0	The top value of the LETIMER is 65535 (0xFFFF)	1	The top value of the LETIMER is given by COMP0									
Value	Description																		
0	The top value of the LETIMER is 65535 (0xFFFF)																		
1	The top value of the LETIMER is given by COMP0																		
8	BUFTOP	0	RW	Buffered Top Set to load COMP1 into COMP0 when REP0 reaches 0, allowing a buffered top value <table border="1"> <thead> <tr> <th>Value</th> <th>Description</th> </tr> </thead> <tbody> <tr> <td>0</td> <td>COMP0 is only written by software</td> </tr> <tr> <td>1</td> <td>COMP1 is set to COMP0 when REP0 reaches 0</td> </tr> </tbody> </table>	Value	Description	0	COMP0 is only written by software	1	COMP1 is set to COMP0 when REP0 reaches 0									
Value	Description																		
0	COMP0 is only written by software																		
1	COMP1 is set to COMP0 when REP0 reaches 0																		
7	OPOL1	0	RW	Output 1 Polarity Defines the idle value of output 1.															
6	OPOL0	0	RW	Output 0 Polarity Defines the idle value of output 0.															
5:4	UFOA1	0x0	RW	Underflow Output Action 1 Defines the action on LETn_O1 on a LETIMER underflow. <table border="1"> <thead> <tr> <th>Value</th> <th>Mode</th> <th>Description</th> </tr> </thead> <tbody> <tr> <td>0</td> <td>NONE</td> <td>LETn_O1 is held at its idle value as defined by OPOL1.</td> </tr> <tr> <td>1</td> <td>TOGGLE</td> <td>LETn_O1 is toggled on CNT underflow.</td> </tr> <tr> <td>2</td> <td>PULSE</td> <td>LETn_O1 is held active for one LFACTK_{LETIMER0} clock cycle on CNT underflow. The output then returns to its idle value as defined by OPOL1.</td> </tr> <tr> <td>3</td> <td>PWM</td> <td>LETn_O1 is set idle on CNT underflow, and active on compare match with COMP1</td> </tr> </tbody> </table>	Value	Mode	Description	0	NONE	LETn_O1 is held at its idle value as defined by OPOL1.	1	TOGGLE	LETn_O1 is toggled on CNT underflow.	2	PULSE	LETn_O1 is held active for one LFACTK _{LETIMER0} clock cycle on CNT underflow. The output then returns to its idle value as defined by OPOL1.	3	PWM	LETn_O1 is set idle on CNT underflow, and active on compare match with COMP1
Value	Mode	Description																	
0	NONE	LETn_O1 is held at its idle value as defined by OPOL1.																	
1	TOGGLE	LETn_O1 is toggled on CNT underflow.																	
2	PULSE	LETn_O1 is held active for one LFACTK _{LETIMER0} clock cycle on CNT underflow. The output then returns to its idle value as defined by OPOL1.																	
3	PWM	LETn_O1 is set idle on CNT underflow, and active on compare match with COMP1																	
3:2	UFOA0	0x0	RW	Underflow Output Action 0 Defines the action on LETn_O0 on a LETIMER underflow. <table border="1"> <thead> <tr> <th>Value</th> <th>Mode</th> <th>Description</th> </tr> </thead> <tbody> <tr> <td>0</td> <td>NONE</td> <td>LETn_O0 is held at its idle value as defined by OPOL0.</td> </tr> <tr> <td>1</td> <td>TOGGLE</td> <td>LETn_O0 is toggled on CNT underflow.</td> </tr> <tr> <td>2</td> <td>PULSE</td> <td>LETn_O0 is held active for one LFACTK_{LETIMER0} clock cycle on CNT underflow. The output then returns to its idle value as defined by OPOL0.</td> </tr> <tr> <td>3</td> <td>PWM</td> <td>LETn_O0 is set idle on CNT underflow, and active on compare match with COMP1</td> </tr> </tbody> </table>	Value	Mode	Description	0	NONE	LETn_O0 is held at its idle value as defined by OPOL0.	1	TOGGLE	LETn_O0 is toggled on CNT underflow.	2	PULSE	LETn_O0 is held active for one LFACTK _{LETIMER0} clock cycle on CNT underflow. The output then returns to its idle value as defined by OPOL0.	3	PWM	LETn_O0 is set idle on CNT underflow, and active on compare match with COMP1
Value	Mode	Description																	
0	NONE	LETn_O0 is held at its idle value as defined by OPOL0.																	
1	TOGGLE	LETn_O0 is toggled on CNT underflow.																	
2	PULSE	LETn_O0 is held active for one LFACTK _{LETIMER0} clock cycle on CNT underflow. The output then returns to its idle value as defined by OPOL0.																	
3	PWM	LETn_O0 is set idle on CNT underflow, and active on compare match with COMP1																	
1:0	REPMODE	0x0	RW	Repeat Mode Allows the repeat counter to be enabled and disabled. <table border="1"> <thead> <tr> <th>Value</th> <th>Mode</th> <th>Description</th> </tr> </thead> <tbody> <tr> <td>0</td> <td>FREE</td> <td>When started, the LETIMER counts down until it is stopped by software.</td> </tr> <tr> <td>1</td> <td>ONESHOT</td> <td>The counter counts REP0 times. When REP0 reaches zero, the counter stops.</td> </tr> <tr> <td>2</td> <td>BUFFERED</td> <td>The counter counts REP0 times. If REP1 has been written, it is loaded into REP0 when REP0 reaches zero. Else the counter stops</td> </tr> <tr> <td>3</td> <td>DOUBLE</td> <td>Both REP0 and REP1 are decremented when the LETIMER wraps around. The LETIMER counts until both REP0 and REP1 are zero</td> </tr> </tbody> </table>	Value	Mode	Description	0	FREE	When started, the LETIMER counts down until it is stopped by software.	1	ONESHOT	The counter counts REP0 times. When REP0 reaches zero, the counter stops.	2	BUFFERED	The counter counts REP0 times. If REP1 has been written, it is loaded into REP0 when REP0 reaches zero. Else the counter stops	3	DOUBLE	Both REP0 and REP1 are decremented when the LETIMER wraps around. The LETIMER counts until both REP0 and REP1 are zero
Value	Mode	Description																	
0	FREE	When started, the LETIMER counts down until it is stopped by software.																	
1	ONESHOT	The counter counts REP0 times. When REP0 reaches zero, the counter stops.																	
2	BUFFERED	The counter counts REP0 times. If REP1 has been written, it is loaded into REP0 when REP0 reaches zero. Else the counter stops																	
3	DOUBLE	Both REP0 and REP1 are decremented when the LETIMER wraps around. The LETIMER counts until both REP0 and REP1 are zero																	

21.5.2 LETIMERn_CMD - Command Register (Async Reg)

For more information about Asynchronous Registers please see Section 5.3 (p. 18) .

21.5.4 LETIMERn_CNT - Counter Value Register

Offset	Bit Position																															
0x00C	31	30	29	28	27	26	25	24	23	22	21	20	19	18	17	16	15	14	13	12	11	10	9	8	7	6	5	4	3	2	1	0
Reset																	0x0000															
Access																	R															
Name																	CNT															

Bit	Name	Reset	Access	Description
31:16	Reserved	To ensure compatibility with future devices, always write bits to 0. More information in Section 2.1 (p. 3)		
15:0	CNT	0x0000	R	Counter Value Use to read the current value of the LETIMER.

21.5.5 LETIMERn_COMP0 - Compare Value Register 0 (Async Reg)

For more information about Asynchronous Registers please see Section 5.3 (p. 18) .

Offset	Bit Position																															
0x010	31	30	29	28	27	26	25	24	23	22	21	20	19	18	17	16	15	14	13	12	11	10	9	8	7	6	5	4	3	2	1	0
Reset																	0x0000															
Access																	RW															
Name																	COMP0															

Bit	Name	Reset	Access	Description
31:16	Reserved	To ensure compatibility with future devices, always write bits to 0. More information in Section 2.1 (p. 3)		
15:0	COMP0	0x0000	RW	Compare Value 0 Compare and optionally top value for LETIMER

21.5.6 LETIMERn_COMP1 - Compare Value Register 1 (Async Reg)

For more information about Asynchronous Registers please see Section 5.3 (p. 18) .

Offset	Bit Position																															
0x014	31	30	29	28	27	26	25	24	23	22	21	20	19	18	17	16	15	14	13	12	11	10	9	8	7	6	5	4	3	2	1	0
Reset																	0x0000															
Access																	RW															
Name																	COMP1															

Bit	Name	Reset	Access	Description
31:16	Reserved	To ensure compatibility with future devices, always write bits to 0. More information in Section 2.1 (p. 3)		
15:0	COMP1	0x0000	RW	Compare Value 1 Compare and optionally buffered top value for LETIMER

21.5.7 LETIMERn_REP0 - Repeat Counter Register 0 (Async Reg)

For more information about Asynchronous Registers please see Section 5.3 (p. 18) .

Offset	Bit Position																															
0x018	31	30	29	28	27	26	25	24	23	22	21	20	19	18	17	16	15	14	13	12	11	10	9	8	7	6	5	4	3	2	1	0
Reset																	0x00															
Access																	RW															
Name																	REP0															

Bit	Name	Reset	Access	Description
31:8	Reserved	To ensure compatibility with future devices, always write bits to 0. More information in Section 2.1 (p. 3)		
7:0	REP0	0x00	RW	Repeat Counter 0 Optional repeat counter.

21.5.8 LETIMERn_REP1 - Repeat Counter Register 1 (Async Reg)

For more information about Asynchronous Registers please see Section 5.3 (p. 18) .

Offset	Bit Position																															
0x01C	31	30	29	28	27	26	25	24	23	22	21	20	19	18	17	16	15	14	13	12	11	10	9	8	7	6	5	4	3	2	1	0
Reset																	0x00															
Access																	RW															
Name																	REP1															

Bit	Name	Reset	Access	Description
31:8	Reserved	To ensure compatibility with future devices, always write bits to 0. More information in Section 2.1 (p. 3)		

Bit	Name	Reset	Access	Description
2	UF	0	RW	Underflow Interrupt Enable Set to enable interrupt on the UF interrupt flag.
1	COMP1	0	RW	Compare Match 1 Interrupt Enable Set to enable interrupt on the COMP1 interrupt flag.
0	COMP0	0	RW	Compare Match 0 Interrupt Enable Set to enable interrupt on the COMP0 interrupt flag.

21.5.13 LETIMERn_FREEZE - Freeze Register

Offset	Bit Position																															
0x030	31	30	29	28	27	26	25	24	23	22	21	20	19	18	17	16	15	14	13	12	11	10	9	8	7	6	5	4	3	2	1	0
Reset																																0
Access																																RW
Name																																REGFREEZE

Bit	Name	Reset	Access	Description
31:1	Reserved	<i>To ensure compatibility with future devices, always write bits to 0. More information in Section 2.1 (p. 3)</i>		
0	REGFREEZE	0	RW	Register Update Freeze When set, the update of the LETIMER is postponed until this bit is cleared. Use this bit to update several registers simultaneously.

Value	Mode	Description
0	UPDATE	Each write access to a LETIMER register is updated into the Low Frequency domain as soon as possible.
1	FREEZE	The LETIMER is not updated with the new written value.

21.5.14 LETIMERn_SYNCBUSY - Synchronization Busy Register

Offset	Bit Position																															
0x034	31	30	29	28	27	26	25	24	23	22	21	20	19	18	17	16	15	14	13	12	11	10	9	8	7	6	5	4	3	2	1	0
Reset																																0
Access																																R
Name																																REP1 REPO COMP1 COMP0 CMD CTRL

Bit	Name	Reset	Access	Description
31:6	Reserved	<i>To ensure compatibility with future devices, always write bits to 0. More information in Section 2.1 (p. 3)</i>		
5	REP1	0	R	LETIMERn_REP1 Register Busy Set when the value written to LETIMERn_REP1 is being synchronized.
4	REPO	0	R	LETIMERn_REPO Register Busy Set when the value written to LETIMERn_REPO is being synchronized.
3	COMP1	0	R	LETIMERn_COMP1 Register Busy Set when the value written to LETIMERn_COMP1 is being synchronized.
2	COMP0	0	R	LETIMERn_COMP0 Register Busy

Bit	Name	Reset	Access	Description
				Set when the value written to LETIMERn_COMP0 is being synchronized.
1	CMD	0	R	LETIMERn_CMD Register Busy Set when the value written to LETIMERn_CMD is being synchronized.
0	CTRL	0	R	LETIMERn_CTRL Register Busy Set when the value written to LETIMERn_CTRL is being synchronized.

21.5.15 LETIMERn_ROUTE - I/O Routing Register

Offset	Bit Position																															
	31	30	29	28	27	26	25	24	23	22	21	20	19	18	17	16	15	14	13	12	11	10	9	8	7	6	5	4	3	2	1	0
0x040																									0x0			0	0			
Reset																																
Access																									RW			RW	RW			
Name																									LOCATION			OUT1PEN	OUT0PEN			

Bit	Name	Reset	Access	Description															
31:10	<i>Reserved</i>	<i>To ensure compatibility with future devices, always write bits to 0. More information in Section 2.1 (p. 3)</i>																	
9:8	LOCATION	0x0	RW	I/O Location Decides the location of the LETIMER I/O pins <table border="1"> <thead> <tr> <th>Value</th> <th>Mode</th> <th>Description</th> </tr> </thead> <tbody> <tr> <td>0</td> <td>LOC0</td> <td>Location 0</td> </tr> <tr> <td>1</td> <td>LOC1</td> <td>Location 1</td> </tr> <tr> <td>2</td> <td>LOC2</td> <td>Location 2</td> </tr> <tr> <td>3</td> <td>LOC3</td> <td>Location 3</td> </tr> </tbody> </table>	Value	Mode	Description	0	LOC0	Location 0	1	LOC1	Location 1	2	LOC2	Location 2	3	LOC3	Location 3
Value	Mode	Description																	
0	LOC0	Location 0																	
1	LOC1	Location 1																	
2	LOC2	Location 2																	
3	LOC3	Location 3																	
7:2	<i>Reserved</i>	<i>To ensure compatibility with future devices, always write bits to 0. More information in Section 2.1 (p. 3)</i>																	
1	OUT1PEN	0	RW	Output 1 Pin Enable When set, output 1 of the LETIMER is enabled <table border="1"> <thead> <tr> <th>Value</th> <th>Description</th> </tr> </thead> <tbody> <tr> <td>0</td> <td>The LETn_O1 pin is disabled</td> </tr> <tr> <td>1</td> <td>The LETn_O1 pin is enabled</td> </tr> </tbody> </table>	Value	Description	0	The LETn_O1 pin is disabled	1	The LETn_O1 pin is enabled									
Value	Description																		
0	The LETn_O1 pin is disabled																		
1	The LETn_O1 pin is enabled																		
0	OUT0PEN	0	RW	Output 0 Pin Enable When set, output 0 of the LETIMER is enabled <table border="1"> <thead> <tr> <th>Value</th> <th>Description</th> </tr> </thead> <tbody> <tr> <td>0</td> <td>The LETn_O0 pin is disabled</td> </tr> <tr> <td>1</td> <td>The LETn_O0 pin is enabled</td> </tr> </tbody> </table>	Value	Description	0	The LETn_O0 pin is disabled	1	The LETn_O0 pin is enabled									
Value	Description																		
0	The LETn_O0 pin is disabled																		
1	The LETn_O0 pin is enabled																		

22 PCNT - Pulse Counter

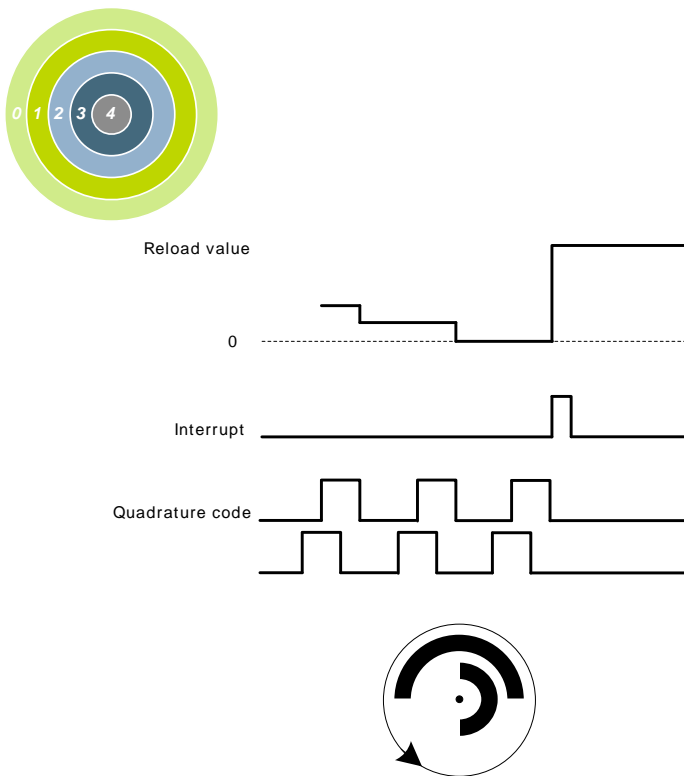

Quick Facts

What?

The Pulse Counter (PCNT) decodes incoming pulses. The module has a quadrature mode which may be used to decode the speed and direction of a mechanical shaft. PCNT can operate in EM0-EM3.

Why?

The PCNT generates an interrupt after a specific number of pulses (or rotations), eliminating the need for timing- or I/O interrupts and CPU processing to measure pulse widths, etc.

How?

PCNT uses the LFACLK or may be externally clocked from a pin. The module incorporates an 8-bit up/down-counter to keep track of incoming pulses or rotations.

22.1 Introduction

The Pulse Counter (PCNT) can be used for counting incoming pulses on a single input or to decode quadrature encoded inputs. It can run from the internal LFACLK (EM0-EM2) while counting pulses on the PCNTn_S0IN pin or using this pin as an external clock source (EM0-EM3) that runs both the PCNT counter and register access.

22.2 Features

- 8-bit counter with reload register
-
- Single input oversampling up/down counter mode (EM0-EM2)
- Externally clocked single input pulse up/down counter mode (EM0-EM3)
- Externally clocked quadrature decoder mode (EM0-EM3)
- Interrupt on counter underflow and overflow
- Interrupt when a direction change is detected (quadrature decoder mode only)
- Optional pulse width filter
- Optional pulse width filter
- Optional input inversion/edge detect select

22.3 Functional Description

An overview of the PCNT module is shown in Figure 22.1 (p. 310) .

Figure 22.1. PCNT Overview

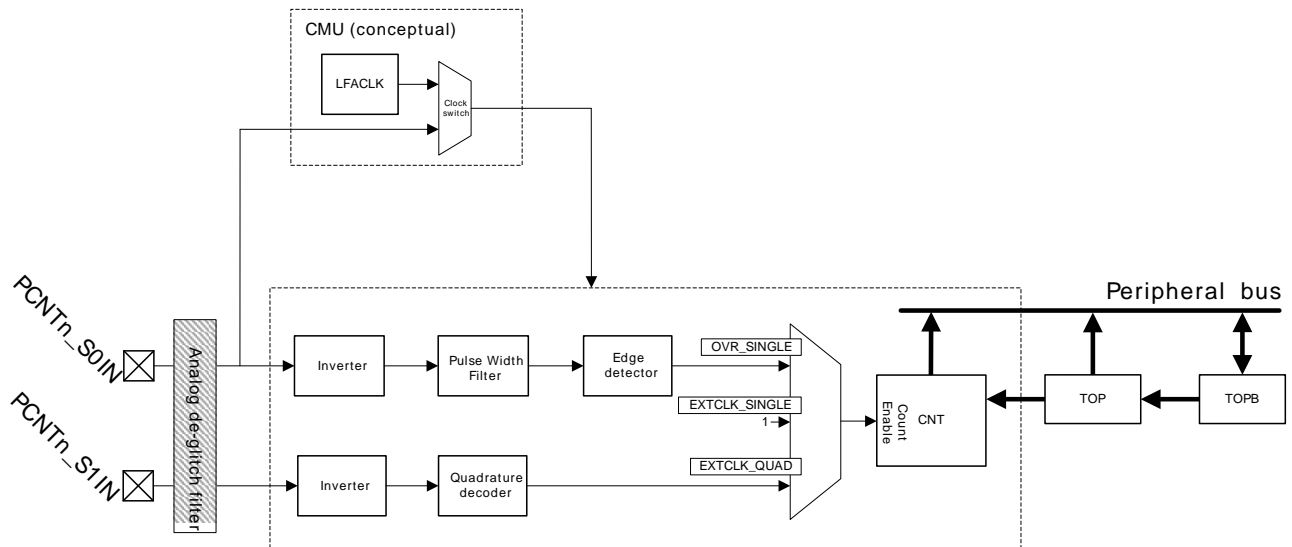

22.3.1 Pulse Counter Modes

The pulse counter can operate in single input oversampling mode (OVSSINGLE), externally clocked single input counter mode (EXTCLKSINGLE) and externally clocked quadrature decoder mode (EXTCLKQUAD). The following sections describe operation of each of the three modes and how they are enabled. Input timing constraints are described in Section 22.3.3 (p. 312) and Section 22.3.4 (p. 313).

22.3.1.1 Single Input Oversampling Mode

This mode is enabled by writing OVSSINGLE (0x1) to the MODE field in the PCNTn_CTRL register and disabled by writing DISABLE (0x0) to the same field. The LFACLK is configured from the registers in the Clock Management Unit (CMU), Chapter 11 (p. 92).

The optional pulse width filter is enabled by writing 1 to the FILT bit in the PCNTn_CTRL register. Additionally, the PCNTn_S0IN input may be inverted, so that falling edges are counted, by writing 1 to the EDGE bit in the PCNTn_CTRL register.

PCNTn_S0IN is the only observed input in this mode. This input is sampled by the LFACLK and the number of detected positive or negative edges on PCNTn_S0IN appears in PCNTn_CNT. The counter may be configured to count down by writing 1 to the CNTDIR bit in PCNTn_CTRL. Default is to count up.

Only the underflow (UF) and overflow (OF) interrupt flags are set in this mode.

22.3.1.2 Externally Clocked Single Input Counter Mode

This mode is enabled by writing EXTCLKSINGLE (0x2) to the MODE field in the PCNTn_CTRL register and disabled by writing DISABLE (0x0) to the same field. The external pin clock source must be configured from the registers in the CMU (Chapter 11 (p. 92)).

Positive edges on PCNTn_S0IN are used to clock the counter. PCNTn_S1IN is ignored in this mode. As the LFACLK is not used in this mode, the PCNT module can operate in EM3. Like in the oversampling mode, the counter may be configured to count down by writing 1 to the CNTDIR bit in the PCNTn_CTRL register. Default is to count up.

The digital pulse width filter is not available in this mode. The analog de-glitch filter in the GPIO pads is capable of removing some unwanted noise. However, this mode may be susceptible to spikes and

unintended pulses from devices such as mechanical switches, and is therefore most suited to take input from electronic sensors etc. that generate single wire pulses.

Only the underflow (UF) and overflow (OF) interrupt flags are set in this mode.

22.3.1.3 Externally Clocked Quadrature Decoder Mode

This mode is enabled by writing EXTCLKQUAD (0x3) to the MODE field in PCNTn_CTRL and disabled by writing DISABLE (0x0) to the same field. The external pin clock source must be configured from the registers in the CMU, (Chapter 11 (p. 92)).

Both edges on PCNTn_S0IN pin are used to sample PCNTn_S1IN pin to decode the quadrature code. Consequently, this mode does not depend on the internal LFACLK and may be operated in EM3. A quadrature coded signal contains information about the relative speed and direction of a rotating shaft as illustrated by Figure 22.2 (p. 311) , hence the direction of the counter register PCNTn_CNT is controlled automatically.

Figure 22.2. PCNT Quadrature Coding

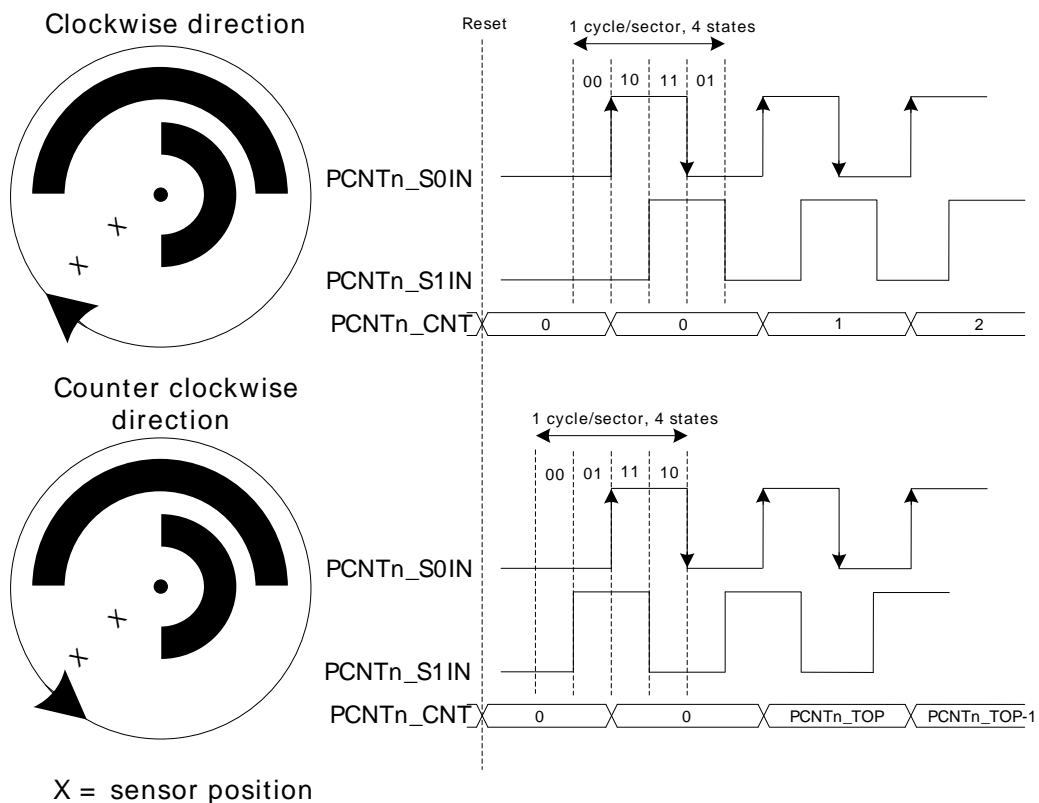

If PCNTn_S0IN leads PCNTn_S1IN in phase, the direction is clockwise, and if it lags in phase the direction is counter-clockwise. Although the direction is automatically detected, the detected direction may be inverted by writing 1 to the EDGE bit in the PCNTn_CTRL register. Default behavior is illustrated by Figure 22.2 (p. 311) .

The counter direction may be read from the DIR bit in the PCNTn_STATUS register. Additionally, the DIRCNG interrupt in the PCNTn_IF register is generated when a direction change is detected. When a change is detected, the DIR bit in the PCNTn_STATUS register must be read to determine the current new direction.

Note

The sector disc illustrated in the figure may be finer grained in some systems. Typically, they may generate 2-4 PCNTn_S0IN wave periods per 360° rotation.

The direction of the quadrature code and control of the counter is generated by the simple binary function outlined by Table 22.1 (p. 312). Note that this function also filters some invalid inputs that may occur when the shaft changes direction or temporarily toggles direction.

Table 22.1. PCNT QUAD Mode Counter Control Function

Inputs		Control/Status	
S1IN posedge	S1IN negedge	Count Enable	CNTDIR status bit
0	0	0	0
0	1	1	0
1	0	1	1
1	1	0	0

Note

PCNTn_S1IN is sampled on both edges of PCNTn_S0IN.

22.3.2 Register Access

The counter-clock domain may be clocked externally. To update the counter-clock domain registers from software in this mode, 2-3 clock pulses on the external clock are needed to synchronize accesses to the externally clocked domain. Clock source switching is controlled from the registers in the CMU (Chapter 11 (p. 92)).

When the RSTEN bit in the PCNTn_CTRL register is set to 1, the PCNT clock domain is asynchronously held in reset. The reset is synchronously released two PCNT clock edges after the RSTEN bit in the PCNTn_CTRL register is cleared by software. This asynchronous reset restores the reset values in PCNTn_TOP, PCNTn_CNT and other control registers in the PCNT clock domain.

Since this module is a Low Energy Peripheral, and runs off a clock which is asynchronous to the HFCORECLK, special considerations must be taken when accessing registers. Please refer to Section 5.3 (p. 18) for a description on how to perform register accesses to Low Energy Peripherals.

Note

PCNTn_TOP and PCNTn_CNT are read-only registers. When writing to PCNTn_TOPB, make sure that the counter value, PCNTn_CNT, can not exceed the value written to PCNTn_TOPB within two clock cycles.

22.3.3 Clock Sources

The 32 kHz LFACTK is one of two possible clock sources. The clock select register is described in Chapter 11 (p. 92). The default clock source is the LFACTK.

This PCNT module may also use PCNTn_S0IN as an external clock to clock the counter (EXTCLKSINGLE mode) and to sample PCNTn_S1IN (EXTCLKQUAD mode). Setup, hold and max frequency constraints for PCNTn_S0IN and PCNTn_S1IN for these modes are specified in the device datasheet.

To use this module, the LE interface clock must be enabled in CMU_HFCORECLKEN0, in addition to the module clock.

Note

PCNT Clock Domain Reset, RSTEN, should be set when changing clock source for PCNT. If changing to an external clock source, the clock pin has to be enabled as input prior to

deasserting RSTEN. Changing clock source without asserting RSTEN results in undefined behaviour.

22.3.4 Input Filter

An optional pulse width filter is available in OVSSINGLE mode. The filter is enabled by writing 1 to the FILT bit in the PCNTn_CTRL register. When enabled, the high and low periods of PCNTn_S0IN must be stable for 5 consecutive clock cycles before the edge is passed to the edge detector.

In EXTCLKSINGLE and EXTCLKQUAD mode, there is no digital pulse width filter available.

22.3.5 Edge Polarity

The edge polarity can be set by configuring the EDGE bit in the PCNTn_CTRL register. When this bit is cleared, the pulse counter counts positive edges in OVSSINGLE mode and negative edges if the bit is set.

In EXTCLKQUAD mode, the EDGE bit in PCNTn_CTRL inverts the direction of the counter (which is automatically detected).

Note

The EDGE bit in PCNTn_CTRL has no effect in EXTCLKSINGLE mode.

22.3.6 PRS Sources

The PCNT module does not generate or receive any PRS events.

22.3.7 Interrupts

The interrupt generated by PCNT uses the PCNTn_INT interrupt vector. Software must read the PCNTn_IF register to determine which module interrupt that generated the vector invocation.

22.3.7.1 Underflow and Overflow Interrupts

The underflow interrupt flag (UF) is set when the counter counts down from 0. I.e. when the value of the counter is 0 and a new pulse is received. The PCNTn_CNT register is loaded with the PCNTn_TOP value after this event.

The overflow interrupt flag (OF) is set when the counter counts up from the PCNTn_TOP (reload) value. I.e. if PCNTn_CNT = PCNTn_TOP and a new pulse is received. The PCNTn_CNT register is loaded with the value 0 after this event.

22.3.7.2 Direction Change Interrupt

The PCNTn_PCNT module sets the DIRCNG interrupt flag (PCNTn_IF register) when the direction of the quadrature code changes. The behavior of this interrupt is illustrated by Figure 22.3 (p. 314) .

Figure 22.3. PCNT Direction Change Interrupt (DIRCNG) Generation

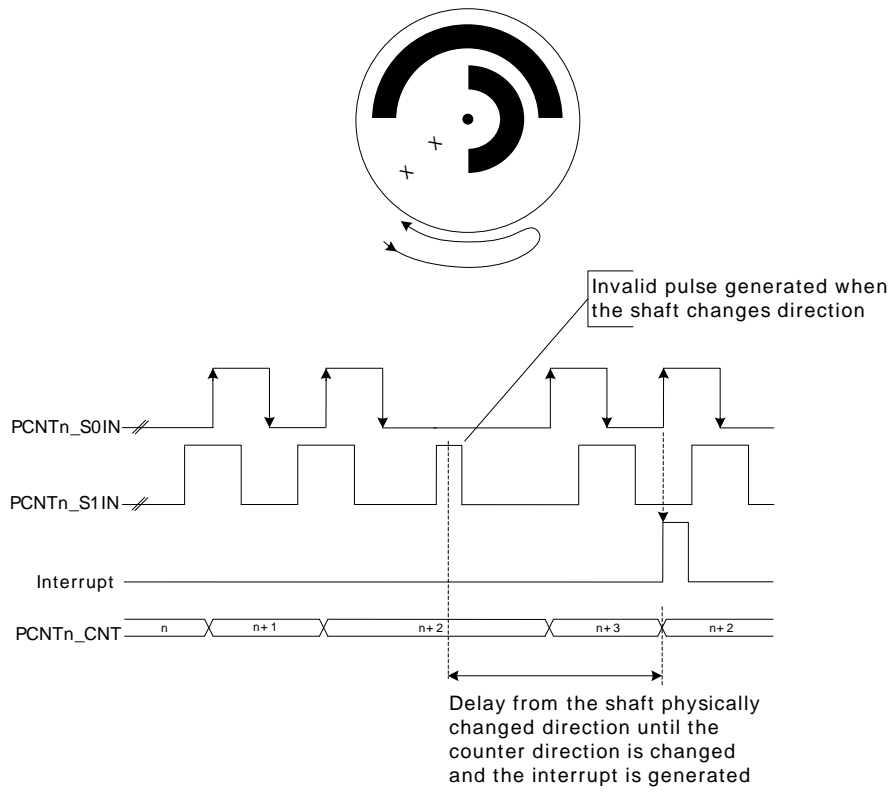

22.4 Register Map

The offset register address is relative to the registers base address.

Offset	Name	Type	Description
0x000	PCNTn_CTRL	RW	Control Register
0x004	PCNTn_CMD	W1	Command Register
0x008	PCNTn_STATUS	R	Status Register
0x00C	PCNTn_CNT	R	Counter Value Register
0x010	PCNTn_TOP	R	Top Value Register
0x014	PCNTn_TOPB	RW	Top Value Buffer Register
0x018	PCNTn_IF	R	Interrupt Flag Register
0x01C	PCNTn_IFS	W1	Interrupt Flag Set Register
0x020	PCNTn_IFC	W1	Interrupt Flag Clear Register
0x024	PCNTn_IEN	RW	Interrupt Enable Register
0x028	PCNTn_ROUTE	RW	I/O Routing Register
0x02C	PCNTn_FREEZE	RW	Freeze Register
0x030	PCNTn_SYNCBUSY	R	Synchronization Busy Register

22.5 Register Description

22.5.1 PCNTn_CTRL - Control Register (Async Reg)

For more information about Asynchronous Registers please see Section 5.3 (p. 18) .

Offset	Bit Position																															
	31	30	29	28	27	26	25	24	23	22	21	20	19	18	17	16	15	14	13	12	11	10	9	8	7	6	5	4	3	2	1	0
0x000																																
Reset																									0	0	0	0	0x0			
Access																									RW	RW	RW	RW	RW			
Name																									RSTEN	FILT	EDGE	CNTDIR	MODE			

Bit	Name	Reset	Access	Description									
31:6	<i>Reserved</i>	<i>To ensure compatibility with future devices, always write bits to 0. More information in Section 2.1 (p. 3)</i>											
5	RSTEN	0	RW	Enable PCNT Clock Domain Reset The PCNT clock domain is asynchronously held in reset when this bit is set. The reset is synchronously released two PCNT clock edges after this bit is cleared. If external clock used the reset should be performed by setting and clearing the bit without pending for SYNCBUSY bit.									
4	FILT	0	RW	Enable Digital Pulse Width Filter The filter passes all high and low periods that are at least 5 clock cycles long. This filter is only available in OVSSINGLE mode.									
3	EDGE	0	RW	Edge Select Determines the polarity of the incoming edges. This bit should be written when PCNT is in DISABLE mode, otherwise the behavior is unpredictable. This bit is ignored in EXTCLKSINGLE mode.									
		<table border="1"> <thead> <tr> <th>Value</th> <th>Mode</th> <th>Description</th> </tr> </thead> <tbody> <tr> <td>0</td> <td>POS</td> <td>Positive edges on the PCNTn_S0IN inputs are counted in OVSSINGLE mode.</td> </tr> <tr> <td>1</td> <td>NEG</td> <td>Negative edges on the PCNTn_S0IN inputs are counted in OVSSINGLE mode, and the counter direction is inverted in EXTCLKQUAD mode.</td> </tr> </tbody> </table>		Value	Mode	Description	0	POS	Positive edges on the PCNTn_S0IN inputs are counted in OVSSINGLE mode.	1	NEG	Negative edges on the PCNTn_S0IN inputs are counted in OVSSINGLE mode, and the counter direction is inverted in EXTCLKQUAD mode.	
Value	Mode	Description											
0	POS	Positive edges on the PCNTn_S0IN inputs are counted in OVSSINGLE mode.											
1	NEG	Negative edges on the PCNTn_S0IN inputs are counted in OVSSINGLE mode, and the counter direction is inverted in EXTCLKQUAD mode.											

Bit	Name	Reset	Access	Description
2	CNTDIR	0	RW	Non-Quadrature Mode Counter Direction Control The direction of the counter must be set in the OVSSINGLE and EXTCLKSINGLE modes. This bit is ignored in EXTCLKQUAD mode as the direction is automatically detected.
	Value	Mode	Description	
	0	UP	Up counter mode	
	1	DOWN	Down counter mode	
1:0	MODE	0x0	RW	Mode Select Selects the mode of operation. The corresponding clock source must be selected from the CMU.
	Value	Mode	Description	
	0	DISABLE	The module is disabled	
	1	OVSSINGLE	Single input LFACTK oversampling mode (available in EM0-EM2)	
	2	EXTCLKSINGLE	Externally clocked single input counter mode (available in EM0-EM3)	
	3	EXTCLKQUAD	Externally clocked quadrature decoder mode (available in EM0-EM3)	

22.5.2 PCNTn_CMD - Command Register (Async Reg)

For more information about Asynchronous Registers please see Section 5.3 (p. 18) .

Offset	Bit Position																															
0x004	31	30	29	28	27	26	25	24	23	22	21	20	19	18	17	16	15	14	13	12	11	10	9	8	7	6	5	4	3	2	1	0
Reset																															0	0
Access																															W1	W1
Name																															LTOPBIM	LCNTIM

Bit	Name	Reset	Access	Description
31:2	Reserved	To ensure compatibility with future devices, always write bits to 0. More information in Section 2.1 (p. 3)		
1	LTOPBIM	0	W1	Load TOPB Immediately This bit has no effect since TOPB is not buffered and it is loaded directly into TOP. For EFM32G revisions A and B: Load PCNTn_TOPB into PCNTn_TOP. Please see the device datasheet for a description on how to extract the chip revision.
0	LCNTIM	0	W1	Load CNT Immediately Load PCNTn_TOP into PCNTn_CNT on the next counter clock cycle.

22.5.3 PCNTn_STATUS - Status Register

Offset	Bit Position																															
0x008	31	30	29	28	27	26	25	24	23	22	21	20	19	18	17	16	15	14	13	12	11	10	9	8	7	6	5	4	3	2	1	0
Reset																															0	0
Access																															R	R
Name																															DIR	

Bit	Name	Reset	Access	Description
31:1	Reserved	To ensure compatibility with future devices, always write bits to 0. More information in Section 2.1 (p. 3)		

Bit	Name	Reset	Access	Description									
0	DIR	0	R	Current Counter Direction Current direction status of the counter. This bit is valid in EXTCLKQUAD mode only.									
<table border="1"> <thead> <tr> <th>Value</th> <th>Mode</th> <th>Description</th> </tr> </thead> <tbody> <tr> <td>0</td> <td>UP</td> <td>Up counter mode (clockwise in EXTCLKQUAD mode with the NEDGE bit in PCNTn_CTRL set to 0)</td> </tr> <tr> <td>1</td> <td>DOWN</td> <td>Down counter mode</td> </tr> </tbody> </table>					Value	Mode	Description	0	UP	Up counter mode (clockwise in EXTCLKQUAD mode with the NEDGE bit in PCNTn_CTRL set to 0)	1	DOWN	Down counter mode
Value	Mode	Description											
0	UP	Up counter mode (clockwise in EXTCLKQUAD mode with the NEDGE bit in PCNTn_CTRL set to 0)											
1	DOWN	Down counter mode											

22.5.4 PCNTn_CNT - Counter Value Register

Offset	Bit Position																															
0x00C	31	30	29	28	27	26	25	24	23	22	21	20	19	18	17	16	15	14	13	12	11	10	9	8	7	6	5	4	3	2	1	0
Reset																	0x0000															
Access																	R															
Name																	CNT															

Bit	Name	Reset	Access	Description
31:16	Reserved	<i>To ensure compatibility with future devices, always write bits to 0. More information in Section 2.1 (p. 3)</i>		
15:0	CNT	0x0000	R	Counter Value Gives read access to the counter.

22.5.5 PCNTn_TOP - Top Value Register

Offset	Bit Position																															
0x010	31	30	29	28	27	26	25	24	23	22	21	20	19	18	17	16	15	14	13	12	11	10	9	8	7	6	5	4	3	2	1	0
Reset																	0x00FF															
Access																	R															
Name																	TOP															

Bit	Name	Reset	Access	Description
31:16	Reserved	<i>To ensure compatibility with future devices, always write bits to 0. More information in Section 2.1 (p. 3)</i>		
15:0	TOP	0x00FF	R	Counter Top Value When counting down, this value is reloaded into PCNTn_CNT when counting past 0. When counting up, 0 is written to the PCNTn_CNT register when counting past this value.

22.5.6 PCNTn_TOPB - Top Value Buffer Register (Async Reg)

For more information about Asynchronous Registers please see Section 5.3 (p. 18) .

Offset	Bit Position																															
0x014	31	30	29	28	27	26	25	24	23	22	21	20	19	18	17	16	15	14	13	12	11	10	9	8	7	6	5	4	3	2	1	0
Reset																	0x00FF															
Access																	RW															
Name																	TOPB															

Bit	Name	Reset	Access	Description
31:16	Reserved	To ensure compatibility with future devices, always write bits to 0. More information in Section 2.1 (p. 3)		
15:0	TOPB	0x00FF	RW	Counter Top Buffer Loaded automatically to TOP when written. For EFM32G revisions A and B: Loaded into TOP when LTOPBIM in PCNTn_CMD register is set. Please see the device datasheet for a description on how to extract the chip revision.

22.5.7 PCNTn_IF - Interrupt Flag Register

Offset	Bit Position																															
0x018	31	30	29	28	27	26	25	24	23	22	21	20	19	18	17	16	15	14	13	12	11	10	9	8	7	6	5	4	3	2	1	0
Reset																													R	0	2	
Access																													R	0	1	
Name																													DIRCNG	OF	UF	

Bit	Name	Reset	Access	Description
31:3	Reserved	To ensure compatibility with future devices, always write bits to 0. More information in Section 2.1 (p. 3)		
2	DIRCNG	0	R	Direction Change Detect Interrupt Flag Set when the count direction changes. Set in EXTCLKQUAD mode only.
1	OF	0	R	Overflow Interrupt Read Flag Set when a CNT overflow occurs
0	UF	0	R	Underflow Interrupt Read Flag Set when a CNT underflow occurs

22.5.8 PCNTn_IFS - Interrupt Flag Set Register

Offset	Bit Position																															
0x01C	31	30	29	28	27	26	25	24	23	22	21	20	19	18	17	16	15	14	13	12	11	10	9	8	7	6	5	4	3	2	1	0
Reset																													W1	0	2	
Access																													W1	0	1	
Name																													DIRCNG	OF	UF	

Bit	Name	Reset	Access	Description
31:3	Reserved	To ensure compatibility with future devices, always write bits to 0. More information in Section 2.1 (p. 3)		
2	DIRCNG	0	W1	Direction Change Detect Interrupt Set Write to 1 to set the direction change interrupt flag
1	OF	0	W1	Overflow Interrupt Set Write to 1 to set the overflow interrupt flag
0	UF	0	W1	Underflow interrupt set Write to 1 to set the underflow interrupt flag

22.5.9 PCNTn_IFC - Interrupt Flag Clear Register

Offset	Bit Position																															
0x020	31	30	29	28	27	26	25	24	23	22	21	20	19	18	17	16	15	14	13	12	11	10	9	8	7	6	5	4	3	2	1	0
Reset																												0	0	0		
Access																												W1	W1	W1		
Name																												DIRCNG	OF	UF		

Bit	Name	Reset	Access	Description
31:3	Reserved	To ensure compatibility with future devices, always write bits to 0. More information in Section 2.1 (p. 3)		
2	DIRCNG	0	W1	Direction Change Detect Interrupt Clear Write to 1 to clear the direction change detect interrupt flag
1	OF	0	W1	Overflow Interrupt Clear Write to 1 to clear the overflow interrupt flag
0	UF	0	W1	Underflow Interrupt Clear Write to 1 to clear the underflow interrupt flag

22.5.10 PCNTn_IEN - Interrupt Enable Register

Offset	Bit Position																															
0x024	31	30	29	28	27	26	25	24	23	22	21	20	19	18	17	16	15	14	13	12	11	10	9	8	7	6	5	4	3	2	1	0
Reset																												0	0	0		
Access																												RW	RW	RW		
Name																												DIRCNG	OF	UF		

Bit	Name	Reset	Access	Description
31:3	Reserved	To ensure compatibility with future devices, always write bits to 0. More information in Section 2.1 (p. 3)		
2	DIRCNG	0	RW	Direction Change Detect Interrupt Enable Enable the direction change detect interrupt.
1	OF	0	RW	Overflow Interrupt Enable

Bit	Name	Reset	Access	Description
	Enable the overflow interrupt			
0	UF	0	RW	Underflow Interrupt Enable
	Enable the underflow interrupt			

22.5.11 PCNTn_ROUTE - I/O Routing Register

Offset	Bit Position																															
0x028	31	30	29	28	27	26	25	24	23	22	21	20	19	18	17	16	15	14	13	12	11	10	9	8	7	6	5	4	3	2	1	0
Reset																								0x0								
Access																								RW								
Name																								LOCATION								

Bit	Name	Reset	Access	Description
31:10	Reserved	To ensure compatibility with future devices, always write bits to 0. More information in Section 2.1 (p. 3)		
9:8	LOCATION	0x0	RW	I/O Location
	Defines the location of the PCNT input pins. E.g. PCNTn_S0#0, #1 or #2.			
	Value	Mode	Description	
	0	LOC0	Select location 0	
	1	LOC1	Select location 1	
	2	LOC2	Select location 2	
7:0	Reserved	To ensure compatibility with future devices, always write bits to 0. More information in Section 2.1 (p. 3)		

22.5.12 PCNTn_FREEZE - Freeze Register

Offset	Bit Position																															
0x02C	31	30	29	28	27	26	25	24	23	22	21	20	19	18	17	16	15	14	13	12	11	10	9	8	7	6	5	4	3	2	1	0
Reset																																0
Access																																RW
Name																																REGFREEZE

Bit	Name	Reset	Access	Description
31:1	Reserved	To ensure compatibility with future devices, always write bits to 0. More information in Section 2.1 (p. 3)		
0	REGFREEZE	0	RW	Register Update Freeze
	When set, the update of the PCNT clock domain is postponed until this bit is cleared. Use this bit to update several registers simultaneously.			
	Value	Mode	Description	
	0	UPDATE	Each write access to a PCNT register is updated into the Low Frequency domain as soon as possible.	
	1	FREEZE	The PCNT clock domain is not updated with the new written value.	

22.5.13 PCNTn_SYNCBUSY - Synchronization Busy Register

Offset	Bit Position																															
0x030	31	30	29	28	27	26	25	24	23	22	21	20	19	18	17	16	15	14	13	12	11	10	9	8	7	6	5	4	3	2	1	0
Reset																											0	0	0	0		
Access																											R	R	R	R		
Name																											TOPB	CMD	CTRL			

Bit	Name	Reset	Access	Description
31:3	Reserved	To ensure compatibility with future devices, always write bits to 0. More information in Section 2.1 (p. 3)		
2	TOPB	0	R	PCNTn_TOPB Register Busy Set when the value written to PCNTn_TOPB is being synchronized.
1	CMD	0	R	PCNTn_CMD Register Busy Set when the value written to PCNTn_CMD is being synchronized.
0	CTRL	0	R	PCNTn_CTRL Register Busy Set when the value written to PCNTn_CTRL is being synchronized.

23 ACMP - Analog Comparator

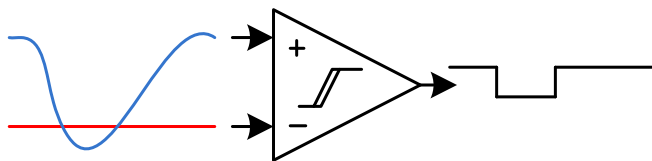
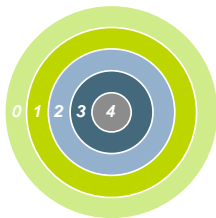

Quick Facts

What?

The ACMP (Analog Comparator) compares two analog signals and returns a digital value telling which is greater.

Why?

Applications often do not need to know the exact value of an analog signal, only if it has passed a certain threshold. Often the voltage must be monitored continuously, which requires extremely low power consumption.

How?

Available down to Energy Mode 3 and using as little as 100 nA, the ACMP can wake up the system when input signals pass the threshold. The analog comparator can compare two analog signals or one analog signal and a highly configurable internal reference.

23.1 Introduction

The Analog Comparator is used to compare the voltage of two analog inputs, with a digital output indicating which input voltage is higher. Inputs can either be one of the selectable internal references or from external pins. Response time and thereby also the current consumption can be configured by altering the current supply to the comparator.

23.2 Features

- 8 selectable external positive inputs
- 8 selectable external negative inputs
- 3 selectable internal negative inputs
 - Internal 1.25 V bandgap
 - Internal 2.5 V bandgap
 - V_{DD} scaled by 64 selectable factors
- Low power mode for internal V_{DD} and bandgap references
- Selectable hysteresis
 - 8 levels between 0 and ± 70 mV
- Selectable response time
- Asynchronous interrupt generation on selectable edges
 - Rising edge
 - Falling edge
 - Both edges
- Operational in EM0-EM3
- Dedicated capacitive sense mode with up to 8 inputs
 - Adjustable internal resistor
- Configurable inversion of comparator output
- Configurable output when inactive

- Comparator output direct on PRS
- Comparator output on GPIO through alternate functionality
 - Output inversion available

23.3 Functional Description

An overview of the ACMP is shown in Figure 23.1 (p. 323) .

Figure 23.1. ACMP Overview

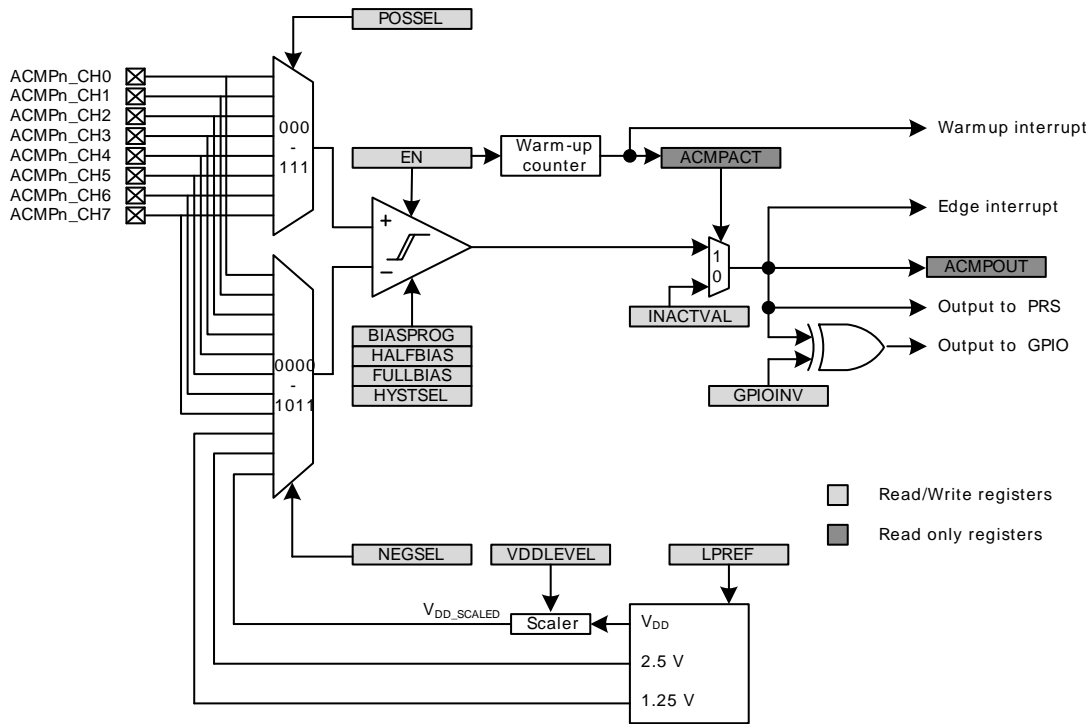

The comparator has two analog inputs, one positive and one negative. When the comparator is active, the output indicates which of the two input voltages is higher. When the voltage on the positive input is higher than the voltage on the negative input, the digital output is high and vice versa.

The output of the comparator can be read in the ACMPOUT bit in ACMPn_STATUS. It is possible to switch inputs while the comparator is enabled, but all other configuration should only be changed while the comparator is disabled.

23.3.1 Warm-up Time

The analog comparator is enabled by setting the EN bit in ACMPn_CTRL. When this bit is set, the comparator must stabilize before becoming active and the outputs can be used. This time period is called the warm-up time. The warm-up time is a configurable number of peripheral clock (HFPERCLK) cycles, set in WARMTIME, which should be set to at least 10 μ s but lengthens to up to 1ms if LPREF is enabled. The ACMP should always start in active mode and then enable the LPREF after warm-up time. When the comparator is enabled and warmed up, the ACMPACT bit in ACMPn_STATUS will indicate that the comparator is active. The output value when the comparator is inactive is set to the value in INACTVAL in ACMPn_CTRL (see Figure 23.1 (p. 323)).

An edge interrupt will be generated after the warm-up time if edge interrupt is enabled and the value set in INACTVAL is different from ACMPOUT after warm-up.

One should wait until the warm-up period is over before entering EM2 or EM3, otherwise no comparator interrupts will be detected. EM1 can still be entered during warm-up. After the warm-up period is completed, interrupts will be detected in EM2 and EM3.

23.3.2 Response Time

There is a delay from when the actual input voltage changes polarity, to when the output toggles. This period is called the response time and can be altered by increasing or decreasing the bias current to the comparator through the BIASPROG, FULLBIAS and HALFBIAS fields in the ACMPn_CTRL register, as described in Table 23.1 (p. 324). Setting the HALFBIAS bit in ACMPn_CTRL effectively halves the current as observed in Table 23.1 (p. 324). Setting a lower bias current will result in lower power consumption, but a longer response time.

If the FULLBIAS bit is set, the highest hysteresis level should be used to avoid glitches on the output.

Table 23.1. Bias Configuration

BIASPROG	Bias Current (μ A)			
	FULLBIAS=0, HALFBIAS=1	FULLBIAS=0, HALFBIAS=0	FULLBIAS=1, HALFBIAS=1	FULLBIAS=1, HALFBIAS=0
0b0000	0.05	0.1	3.3	6.5
0b0001	0.1	0.2	6.5	13
0b0010	0.2	0.4	13	26
0b0011	0.3	0.6	20	39
0b0100	0.4	0.8	26	52
0b0101	0.5	1.0	33	65
0b0110	0.6	1.2	39	78
0b0111	0.7	1.4	46	91
0b1000	1.0	2.0	65	130
0b1001	1.1	2.2	72	143
0b1010	1.2	2.4	78	156
0b1011	1.3	2.6	85	169
0b1100	1.4	2.8	91	182
0b1101	1.5	3.0	98	195
0b1110	1.6	3.2	104	208
0b1111	1.7	3.4	111	221

23.3.3 Hysteresis

In the analog comparator, hysteresis can be configured to 8 different levels, including off which is level 0, through the HYSTSEL field in ACMPn_CTRL. When the hysteresis level is set above 0, the digital output will not toggle until the positive input voltage is at a voltage equal to the hysteresis level above or below the negative input voltage (see Figure 23.2 (p. 325)). This feature can be used to filter out uninteresting input fluctuations around zero and only show changes that are big enough to breach the hysteresis threshold.

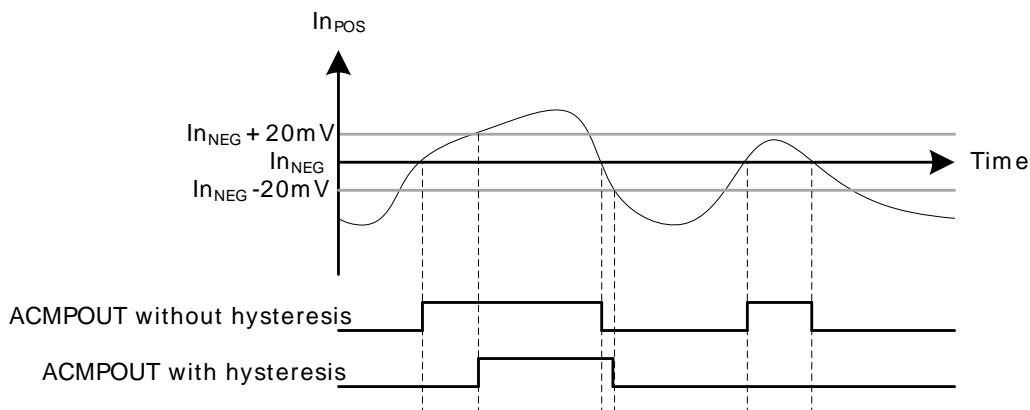
Figure 23.2. 20 mV Hysteresis Selected

23.3.4 Input Selection

The POSSEL and NEGSEL fields in ACMPn_INPUTSEL controls which signals are connected to the two inputs of the comparator. 8 external pins are available for both the negative and positive input. For the negative input, 3 additional internal reference sources are available; 1.25 V bandgap, 2.5V bandgap and V_{DD} . The V_{DD} reference can be scaled by a configurable factor, which is set in VDDLEVEL (in ACMPn_INPUTSEL) according to the following formula:

V_{DD} Scaled

$$V_{DD_SCALED} = V_{DD} \times VDDLEVEL / 63 \quad (23.1)$$

A low power reference mode can be enabled by setting the LPREF bit in ACMPn_INPUTSEL. In this mode, the power consumption in the reference buffer (V_{DD} and bandgap) is lowered at the cost of accuracy. Low power mode will only save power if V_{DD} with VDDLEVEL higher than 0 or a bandgap reference is selected.

Normally the analog comparator input mux is disabled when the EN (in ACMPn_CTRL) bit is set low. However if the MUXEN bit in ACMPn_CTRL is set, the mux is enabled regardless of the EN bit. This will minimize kickback noise on the mux inputs when the EN bit is toggled.

23.3.5 Capacitive Sense Mode

The analog comparator includes specialized hardware for capacitive sensing of passive push buttons. Such buttons are traces on PCB laid out in a way that creates a parasitic capacitor between the button and the ground node. Because a human finger will have a small intrinsic capacitance to ground, the capacitance of the button will increase when the button is touched. The capacitance is measured by including the capacitor in a free-running RC oscillator (see Figure 23.3 (p. 326)). The frequency produced will decrease when the button is touched compared to when it is not touched. By measuring the output frequency with a timer (e.g. through PRS), the change in capacitance can be calculated.

The analog comparator contains a complete feedback loop including an optional internal resistor. This resistor is enabled by setting the CSRESEN bit in ACMPn_INPUTSEL. The resistance can be set to one of four values by configuring the CSRESSEL bits in ACMPn_INPUTSEL. If the internal resistor is not enabled, the circuit will be open. The capacitive sense mode is enabled by setting the NEGSEL field in ACMPn_INPUTSEL to 1011. The input pin is selected through the POSSEL bits in ACMPn_INPUTSEL. The scaled V_{DD} in Figure 23.3 (p. 326) can be altered by configuring the VDDLEVEL in ACMPn_INPUTSEL. It is recommended to set the hysteresis (HYSTSEL in ACMPn_CTRL) higher than the lowest level when using the analog comparator in capacitive sense mode.

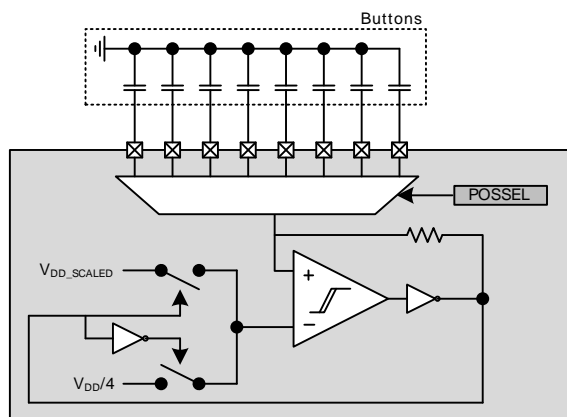
Figure 23.3. Capacitive Sensing Set-up

23.3.6 Interrupts and PRS Output

The analog comparator includes an edge triggered interrupt flag (EDGE in ACMPn_IF). If either IRISE and/or IFALL in ACMPn_CTRL is set, the EDGE interrupt flag will be set on rising and/or falling edge of the comparator output respectively. An interrupt request will be sent if the EDGE interrupt flag in ACMPn_IF is set and enabled through the EDGE bit in ACMPn_IEN. The edge interrupt can also be used to wake up the device from EM3-EM1.

The analog comparator also includes an interrupt flag, WARMUP in ACMPn_IF, which is set when a warm-up sequence has finished. An interrupt request will be sent if the WARMUP interrupt flag in ACMPn_IF is set and enabled through the WARMUP bit in ACMPn_IEN.

The synchronized comparator outputs are also available as a PRS output signals.

23.3.7 Output to GPIO

The output from the comparator and the capacitive sense output are available as alternate functions to the GPIO pins. Set the ACMPPEN bit in ACMPn_ROUTE to enable output to pin, and the LOCATION bits to select output location. When the ACMPPEN bit is set, the selected pin will be set as output regardless of the pin configuration in GPIO. The output to the GPIO can be inverted by setting the GPIOINV bit in ACMPn_CTRL.

23.4 Register Map

The offset register address is relative to the registers base address.

Offset	Name	Type	Description
0x000	ACMPn_CTRL	RW	Control Register
0x004	ACMPn_INPUTSEL	RW	Input Selection Register
0x008	ACMPn_STATUS	R	Status Register
0x00C	ACMPn_IEN	RW	Interrupt Enable Register
0x010	ACMPn_IF	R	Interrupt Flag Register
0x014	ACMPn_IFS	W1	Interrupt Flag Set Register
0x018	ACMPn_IFC	W1	Interrupt Flag Clear Register
0x01C	ACMPn_ROUTE	RW	I/O Routing Register

23.5 Register Description

23.5.1 ACMPn_CTRL - Control Register

Offset	Bit Position																																
0x000	31	30	29	28	27	26	25	24	23	22	21	20	19	18	17	16	15	14	13	12	11	10	9	8	7	6	5	4	3	2	1	0	
Reset	0	1					0x7								0	0							0x0					0x0		0	0	0	0
Access	RW	RW					RW								RW	RW							RW					RW	RW	RW	RW	RW	
Name	FULLBIAS	HALFBIAS					BIASPROG								IFALL	IRISE							WARMTIME					HYSTSEL	GPIOINV	INACTVAL	MUXEN	EN	

Bit	Name	Reset	Access	Description									
31	FULLBIAS	0	RW	Full Bias Current Set this bit to 1 for full bias current in accordance with. Table 23.1 (p. 324) .									
30	HALFBIAS	1	RW	Half Bias Current Set this bit to 1 to halve the bias current in accordance with. Table 23.1 (p. 324) .									
29:28	<i>Reserved</i>	<i>To ensure compatibility with future devices, always write bits to 0. More information in Section 2.1 (p. 3)</i>											
27:24	BIASPROG	0x7	RW	Bias Configuration These bits control the bias current level in accordance with. Table 23.1 (p. 324) .									
23:18	<i>Reserved</i>	<i>To ensure compatibility with future devices, always write bits to 0. More information in Section 2.1 (p. 3)</i>											
17	IFALL	0	RW	Falling Edge Interrupt Sense Set this bit to 1 to set the EDGE interrupt flag on falling edges of comparator output. <table border="1" style="width: 100%; margin-top: 5px;"> <thead> <tr> <th>Value</th> <th>Mode</th> <th>Description</th> </tr> </thead> <tbody> <tr> <td>0</td> <td>DISABLED</td> <td>Interrupt flag is not set on falling edges</td> </tr> <tr> <td>1</td> <td>ENABLED</td> <td>Interrupt flag is set on falling edges</td> </tr> </tbody> </table>	Value	Mode	Description	0	DISABLED	Interrupt flag is not set on falling edges	1	ENABLED	Interrupt flag is set on falling edges
Value	Mode	Description											
0	DISABLED	Interrupt flag is not set on falling edges											
1	ENABLED	Interrupt flag is set on falling edges											
16	IRISE	0	RW	Rising Edge Interrupt Sense Set this bit to 1 to set the EDGE interrupt flag on rising edges of comparator output. <table border="1" style="width: 100%; margin-top: 5px;"> <thead> <tr> <th>Value</th> <th>Mode</th> <th>Description</th> </tr> </thead> <tbody> <tr> <td>0</td> <td>DISABLED</td> <td>Interrupt flag is not set on rising edges</td> </tr> <tr> <td>1</td> <td>ENABLED</td> <td>Interrupt flag is set on rising edges</td> </tr> </tbody> </table>	Value	Mode	Description	0	DISABLED	Interrupt flag is not set on rising edges	1	ENABLED	Interrupt flag is set on rising edges
Value	Mode	Description											
0	DISABLED	Interrupt flag is not set on rising edges											
1	ENABLED	Interrupt flag is set on rising edges											
15:11	<i>Reserved</i>	<i>To ensure compatibility with future devices, always write bits to 0. More information in Section 2.1 (p. 3)</i>											

Bit	Name	Reset	Access	Description																											
10:8	WARTIME	0x0	RW	Warm-up Time Set analog comparator warm-up time.																											
				<table border="1"> <thead> <tr> <th>Value</th> <th>Mode</th> <th>Description</th> </tr> </thead> <tbody> <tr><td>0</td><td>4CYCLES</td><td>4 HFPERCLK cycles</td></tr> <tr><td>1</td><td>8CYCLES</td><td>8 HFPERCLK cycles</td></tr> <tr><td>2</td><td>16CYCLES</td><td>16 HFPERCLK cycles</td></tr> <tr><td>3</td><td>32CYCLES</td><td>32 HFPERCLK cycles</td></tr> <tr><td>4</td><td>64CYCLES</td><td>64 HFPERCLK cycles</td></tr> <tr><td>5</td><td>128CYCLES</td><td>128 HFPERCLK cycles</td></tr> <tr><td>6</td><td>256CYCLES</td><td>256 HFPERCLK cycles</td></tr> <tr><td>7</td><td>512CYCLES</td><td>512 HFPERCLK cycles</td></tr> </tbody> </table>	Value	Mode	Description	0	4CYCLES	4 HFPERCLK cycles	1	8CYCLES	8 HFPERCLK cycles	2	16CYCLES	16 HFPERCLK cycles	3	32CYCLES	32 HFPERCLK cycles	4	64CYCLES	64 HFPERCLK cycles	5	128CYCLES	128 HFPERCLK cycles	6	256CYCLES	256 HFPERCLK cycles	7	512CYCLES	512 HFPERCLK cycles
Value	Mode	Description																													
0	4CYCLES	4 HFPERCLK cycles																													
1	8CYCLES	8 HFPERCLK cycles																													
2	16CYCLES	16 HFPERCLK cycles																													
3	32CYCLES	32 HFPERCLK cycles																													
4	64CYCLES	64 HFPERCLK cycles																													
5	128CYCLES	128 HFPERCLK cycles																													
6	256CYCLES	256 HFPERCLK cycles																													
7	512CYCLES	512 HFPERCLK cycles																													
7	<i>Reserved</i>			<i>To ensure compatibility with future devices, always write bits to 0. More information in Section 2.1 (p. 3)</i>																											
6:4	HYSTSEL	0x0	RW	Hysteresis Select Select hysteresis level. The hysteresis levels can vary, please see the electrical characteristics for the device for more information.																											
				<table border="1"> <thead> <tr> <th>Value</th> <th>Mode</th> <th>Description</th> </tr> </thead> <tbody> <tr><td>0</td><td>HYST0</td><td>No hysteresis</td></tr> <tr><td>1</td><td>HYST1</td><td>~15 mV hysteresis</td></tr> <tr><td>2</td><td>HYST2</td><td>~22 mV hysteresis</td></tr> <tr><td>3</td><td>HYST3</td><td>~29 mV hysteresis</td></tr> <tr><td>4</td><td>HYST4</td><td>~36 mV hysteresis</td></tr> <tr><td>5</td><td>HYST5</td><td>~43 mV hysteresis</td></tr> <tr><td>6</td><td>HYST6</td><td>~50 mV hysteresis</td></tr> <tr><td>7</td><td>HYST7</td><td>~57 mV hysteresis</td></tr> </tbody> </table>	Value	Mode	Description	0	HYST0	No hysteresis	1	HYST1	~15 mV hysteresis	2	HYST2	~22 mV hysteresis	3	HYST3	~29 mV hysteresis	4	HYST4	~36 mV hysteresis	5	HYST5	~43 mV hysteresis	6	HYST6	~50 mV hysteresis	7	HYST7	~57 mV hysteresis
Value	Mode	Description																													
0	HYST0	No hysteresis																													
1	HYST1	~15 mV hysteresis																													
2	HYST2	~22 mV hysteresis																													
3	HYST3	~29 mV hysteresis																													
4	HYST4	~36 mV hysteresis																													
5	HYST5	~43 mV hysteresis																													
6	HYST6	~50 mV hysteresis																													
7	HYST7	~57 mV hysteresis																													
3	GPIOINV	0	RW	Comparator GPIO Output Invert Set this bit to 1 to invert the comparator alternate function output to GPIO.																											
				<table border="1"> <thead> <tr> <th>Value</th> <th>Mode</th> <th>Description</th> </tr> </thead> <tbody> <tr><td>0</td><td>NOTINV</td><td>The comparator output to GPIO is not inverted</td></tr> <tr><td>1</td><td>INV</td><td>The comparator output to GPIO is inverted</td></tr> </tbody> </table>	Value	Mode	Description	0	NOTINV	The comparator output to GPIO is not inverted	1	INV	The comparator output to GPIO is inverted																		
Value	Mode	Description																													
0	NOTINV	The comparator output to GPIO is not inverted																													
1	INV	The comparator output to GPIO is inverted																													
2	INACTVAL	0	RW	Inactive Value The value of this bit is used as the comparator output when the comparator is inactive.																											
				<table border="1"> <thead> <tr> <th>Value</th> <th>Mode</th> <th>Description</th> </tr> </thead> <tbody> <tr><td>0</td><td>LOW</td><td>The inactive value is 0</td></tr> <tr><td>1</td><td>HIGH</td><td>The inactive state is 1</td></tr> </tbody> </table>	Value	Mode	Description	0	LOW	The inactive value is 0	1	HIGH	The inactive state is 1																		
Value	Mode	Description																													
0	LOW	The inactive value is 0																													
1	HIGH	The inactive state is 1																													
1	MUXEN	0	RW	Input Mux Enable Enable Input Mux. Setting the EN bit will also enable the input mux.																											
0	EN	0	RW	Analog Comparator Enable Enable/disable analog comparator.																											

23.5.2 ACMPn_INPUTSEL - Input Selection Register

Offset	Bit Position																																
0x004	31	30	29	28	27	26	25	24	23	22	21	20	19	18	17	16	15	14	13	12	11	10	9	8	7	6	5	4	3	2	1	0	
Reset			0x0					0								1						0x00					0x8					0x0	
Access			RW					RW								RW							RW					RW					RW
Name			CSRESSEL					CSRESEN								LPREF							VDDLLEVEL					NEGSEL					POSSEL

Bit	Name	Reset	Access	Description																																							
31:30	Reserved	To ensure compatibility with future devices, always write bits to 0. More information in Section 2.1 (p. 3)																																									
29:28	CSRESSEL	0x0	RW	Capacitive Sense Mode Internal Resistor Select These bits select the resistance value for the internal capacitive sense resistor. Resulting actual resistor values are given in the device datasheets.																																							
				<table border="1"> <thead> <tr> <th>Value</th> <th>Mode</th> <th>Description</th> </tr> </thead> <tbody> <tr> <td>0</td> <td>RES0</td> <td>Internal capacitive sense resistor value 0</td> </tr> <tr> <td>1</td> <td>RES1</td> <td>Internal capacitive sense resistor value 1</td> </tr> <tr> <td>2</td> <td>RES2</td> <td>Internal capacitive sense resistor value 2</td> </tr> <tr> <td>3</td> <td>RES3</td> <td>Internal capacitive sense resistor value 3</td> </tr> </tbody> </table>	Value	Mode	Description	0	RES0	Internal capacitive sense resistor value 0	1	RES1	Internal capacitive sense resistor value 1	2	RES2	Internal capacitive sense resistor value 2	3	RES3	Internal capacitive sense resistor value 3																								
Value	Mode	Description																																									
0	RES0	Internal capacitive sense resistor value 0																																									
1	RES1	Internal capacitive sense resistor value 1																																									
2	RES2	Internal capacitive sense resistor value 2																																									
3	RES3	Internal capacitive sense resistor value 3																																									
27:25	Reserved	To ensure compatibility with future devices, always write bits to 0. More information in Section 2.1 (p. 3)																																									
24	CSRESEN	0	RW	Capacitive Sense Mode Internal Resistor Enable Enable/disable the internal capacitive sense resistor.																																							
23:17	Reserved	To ensure compatibility with future devices, always write bits to 0. More information in Section 2.1 (p. 3)																																									
16	LPREF	1	RW	Low Power Reference Mode Enable low power mode for VDD and bandgap references.																																							
				<table border="1"> <thead> <tr> <th>Value</th> <th>Description</th> </tr> </thead> <tbody> <tr> <td>0</td> <td>Low power mode disabled</td> </tr> <tr> <td>1</td> <td>Low power mode enabled</td> </tr> </tbody> </table>	Value	Description	0	Low power mode disabled	1	Low power mode enabled																																	
Value	Description																																										
0	Low power mode disabled																																										
1	Low power mode enabled																																										
15:14	Reserved	To ensure compatibility with future devices, always write bits to 0. More information in Section 2.1 (p. 3)																																									
13:8	VDDLEVEL	0x00	RW	VDD Reference Level Select scaling factor for VDD reference level. $V_{DD_SCALED} = V_{DD} \times VDDLEVEL / 63$																																							
7:4	NEGSEL	0x8	RW	Negative Input Select Select negative input.																																							
				<table border="1"> <thead> <tr> <th>Value</th> <th>Mode</th> <th>Description</th> </tr> </thead> <tbody> <tr> <td>0</td> <td>CH0</td> <td>Channel 0 as negative input</td> </tr> <tr> <td>1</td> <td>CH1</td> <td>Channel 1 as negative input</td> </tr> <tr> <td>2</td> <td>CH2</td> <td>Channel 2 as negative input</td> </tr> <tr> <td>3</td> <td>CH3</td> <td>Channel 3 as negative input</td> </tr> <tr> <td>4</td> <td>CH4</td> <td>Channel 4 as negative input</td> </tr> <tr> <td>5</td> <td>CH5</td> <td>Channel 5 as negative input</td> </tr> <tr> <td>6</td> <td>CH6</td> <td>Channel 6 as negative input</td> </tr> <tr> <td>7</td> <td>CH7</td> <td>Channel 7 as negative input</td> </tr> <tr> <td>8</td> <td>1V25</td> <td>1.25 V as negative input</td> </tr> <tr> <td>9</td> <td>2V5</td> <td>2.5 V as negative input</td> </tr> <tr> <td>10</td> <td>VDD</td> <td>Scaled VDD as negative input</td> </tr> <tr> <td>11</td> <td>CAPSENSE</td> <td>Capacitive sense mode</td> </tr> </tbody> </table>	Value	Mode	Description	0	CH0	Channel 0 as negative input	1	CH1	Channel 1 as negative input	2	CH2	Channel 2 as negative input	3	CH3	Channel 3 as negative input	4	CH4	Channel 4 as negative input	5	CH5	Channel 5 as negative input	6	CH6	Channel 6 as negative input	7	CH7	Channel 7 as negative input	8	1V25	1.25 V as negative input	9	2V5	2.5 V as negative input	10	VDD	Scaled VDD as negative input	11	CAPSENSE	Capacitive sense mode
Value	Mode	Description																																									
0	CH0	Channel 0 as negative input																																									
1	CH1	Channel 1 as negative input																																									
2	CH2	Channel 2 as negative input																																									
3	CH3	Channel 3 as negative input																																									
4	CH4	Channel 4 as negative input																																									
5	CH5	Channel 5 as negative input																																									
6	CH6	Channel 6 as negative input																																									
7	CH7	Channel 7 as negative input																																									
8	1V25	1.25 V as negative input																																									
9	2V5	2.5 V as negative input																																									
10	VDD	Scaled VDD as negative input																																									
11	CAPSENSE	Capacitive sense mode																																									
3	Reserved	To ensure compatibility with future devices, always write bits to 0. More information in Section 2.1 (p. 3)																																									
2:0	POSSEL	0x0	RW	Positive Input Select Select positive input.																																							
				<table border="1"> <thead> <tr> <th>Value</th> <th>Mode</th> <th>Description</th> </tr> </thead> <tbody> <tr> <td>0</td> <td>CH0</td> <td>Channel 0 as positive input</td> </tr> <tr> <td>1</td> <td>CH1</td> <td>Channel 1 as positive input</td> </tr> <tr> <td>2</td> <td>CH2</td> <td>Channel 2 as positive input</td> </tr> <tr> <td>3</td> <td>CH3</td> <td>Channel 3 as positive input</td> </tr> <tr> <td>4</td> <td>CH4</td> <td>Channel 4 as positive input</td> </tr> <tr> <td>5</td> <td>CH5</td> <td>Channel 5 as positive input</td> </tr> <tr> <td>6</td> <td>CH6</td> <td>Channel 6 as positive input</td> </tr> <tr> <td>7</td> <td>CH7</td> <td>Channel 7 as positive input</td> </tr> </tbody> </table>	Value	Mode	Description	0	CH0	Channel 0 as positive input	1	CH1	Channel 1 as positive input	2	CH2	Channel 2 as positive input	3	CH3	Channel 3 as positive input	4	CH4	Channel 4 as positive input	5	CH5	Channel 5 as positive input	6	CH6	Channel 6 as positive input	7	CH7	Channel 7 as positive input												
Value	Mode	Description																																									
0	CH0	Channel 0 as positive input																																									
1	CH1	Channel 1 as positive input																																									
2	CH2	Channel 2 as positive input																																									
3	CH3	Channel 3 as positive input																																									
4	CH4	Channel 4 as positive input																																									
5	CH5	Channel 5 as positive input																																									
6	CH6	Channel 6 as positive input																																									
7	CH7	Channel 7 as positive input																																									

23.5.3 ACMPn_STATUS - Status Register

Offset	Bit Position																															
0x008	31	30	29	28	27	26	25	24	23	22	21	20	19	18	17	16	15	14	13	12	11	10	9	8	7	6	5	4	3	2	1	0
Reset																															0	0
Access																															R	R
Name																															ACMPOUT	ACMPACT

Bit	Name	Reset	Access	Description
31:2	<i>Reserved</i>	<i>To ensure compatibility with future devices, always write bits to 0. More information in Section 2.1 (p. 3)</i>		
1	ACMPOUT	0	R	Analog Comparator Output Analog comparator output value.
0	ACMPACT	0	R	Analog Comparator Active Analog comparator active status.

23.5.4 ACMPn_IEN - Interrupt Enable Register

Offset	Bit Position																															
0x00C	31	30	29	28	27	26	25	24	23	22	21	20	19	18	17	16	15	14	13	12	11	10	9	8	7	6	5	4	3	2	1	0
Reset																															0	0
Access																															RW	RW
Name																															WARMUP	EDGE

Bit	Name	Reset	Access	Description
31:2	<i>Reserved</i>	<i>To ensure compatibility with future devices, always write bits to 0. More information in Section 2.1 (p. 3)</i>		
1	WARMUP	0	RW	Warm-up Interrupt Enable Enable/disable interrupt on finished warm-up.
0	EDGE	0	RW	Edge Trigger Interrupt Enable Enable/disable edge triggered interrupt.

23.5.5 ACMPn_IF - Interrupt Flag Register

Offset	Bit Position																															
0x010	31	30	29	28	27	26	25	24	23	22	21	20	19	18	17	16	15	14	13	12	11	10	9	8	7	6	5	4	3	2	1	0
Reset																															0	0
Access																															R	R
Name																															WARMUP	EDGE

Bit	Name	Reset	Access	Description
31:2	Reserved	To ensure compatibility with future devices, always write bits to 0. More information in Section 2.1 (p. 3)		
1	WARMUP	0	R	Warm-up Interrupt Flag Indicates that the analog comparator warm-up period is finished.
0	EDGE	0	R	Edge Triggered Interrupt Flag Indicates that there has been a rising or falling edge on the analog comparator output.

23.5.6 ACMPn_IFS - Interrupt Flag Set Register

Offset	Bit Position																															
0x014	31	30	29	28	27	26	25	24	23	22	21	20	19	18	17	16	15	14	13	12	11	10	9	8	7	6	5	4	3	2	1	0
Reset																											0	0				
Access																											W1	W1				
Name																											WARMUP	EDGE				

Bit	Name	Reset	Access	Description
31:2	Reserved	To ensure compatibility with future devices, always write bits to 0. More information in Section 2.1 (p. 3)		
1	WARMUP	0	W1	Warm-up Interrupt Flag Set Write to 1 to set warm-up finished interrupt flag.
0	EDGE	0	W1	Edge Triggered Interrupt Flag Set Write to 1 to set edge triggered interrupt flag.

23.5.7 ACMPn_IFC - Interrupt Flag Clear Register

Offset	Bit Position																															
0x018	31	30	29	28	27	26	25	24	23	22	21	20	19	18	17	16	15	14	13	12	11	10	9	8	7	6	5	4	3	2	1	0
Reset																											0	0				
Access																											W1	W1				
Name																											WARMUP	EDGE				

Bit	Name	Reset	Access	Description
31:2	Reserved	To ensure compatibility with future devices, always write bits to 0. More information in Section 2.1 (p. 3)		
1	WARMUP	0	W1	Warm-up Interrupt Flag Clear Write to 1 to clear warm-up finished interrupt flag.
0	EDGE	0	W1	Edge Triggered Interrupt Flag Clear Write to 1 to clear edge triggered interrupt flag.

23.5.8 ACMPn_ROUTE - I/O Routing Register

Offset	Bit Position																															
0x01C	31	30	29	28	27	26	25	24	23	22	21	20	19	18	17	16	15	14	13	12	11	10	9	8	7	6	5	4	3	2	1	0
Reset																							0x0						0			
Access																							RW						RW			
Name																							LOCATION						ACMPEN			

Bit	Name	Reset	Access	Description														
31:10	Reserved	To ensure compatibility with future devices, always write bits to 0. More information in Section 2.1 (p. 3)																
9:8	LOCATION	0x0	RW	I/O Location Decides the location of the ACMP I/O pin.														
	<table border="1"> <thead> <tr> <th>Value</th> <th>Mode</th> <th>Description</th> </tr> </thead> <tbody> <tr> <td>0</td> <td>LOC0</td> <td>Location 0</td> </tr> <tr> <td>1</td> <td>LOC1</td> <td>Location 1</td> </tr> <tr> <td>2</td> <td>LOC2</td> <td>Location 2</td> </tr> <tr> <td>3</td> <td>LOC3</td> <td>Location 3</td> </tr> </tbody> </table>	Value	Mode	Description	0	LOC0	Location 0	1	LOC1	Location 1	2	LOC2	Location 2	3	LOC3	Location 3		
Value	Mode	Description																
0	LOC0	Location 0																
1	LOC1	Location 1																
2	LOC2	Location 2																
3	LOC3	Location 3																
7:1	Reserved	To ensure compatibility with future devices, always write bits to 0. More information in Section 2.1 (p. 3)																
0	ACMPEN	0	RW	ACMP Output Pin Enable Enable/disable analog comparator output to pin.														

24 VCMP - Voltage Comparator

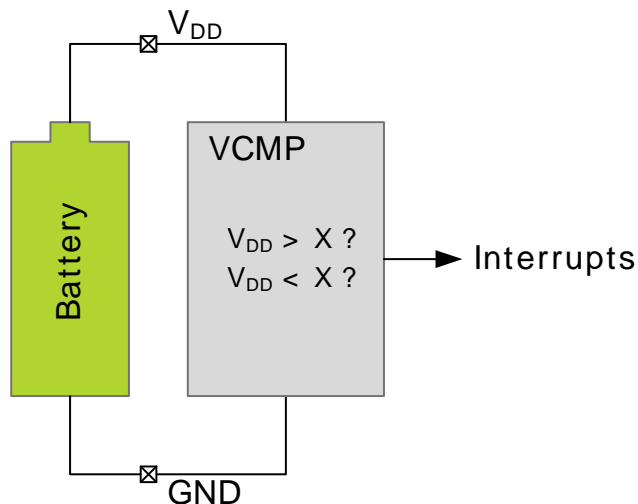
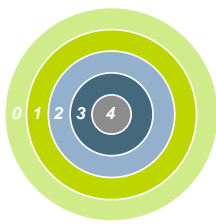

Quick Facts

What?

The Voltage Supply Comparator (VCMP) monitors the input voltage supply and generates software interrupts on events using as little as 100 nA.

Why?

The VCMP can be used for simple power supply monitoring, e.g. for a battery level indicator.

How?

The scaled power supply is compared to a programmable reference voltage, and an interrupt can be generated when the supply is higher or lower than the reference. The VCMP can also be duty-cycled by software to further reduce the energy consumption.

24.1 Introduction

The Voltage Supply Comparator is used to monitor the supply voltage from software. An interrupt can be generated when the supply falls below or rises above a programmable threshold.

Note

Note that VCMP comes in addition to the Power-on Reset and Brown-out Detector peripherals, that both generate reset signals when the voltage supply is insufficient for reliable operation. VCMP does not generate reset, only interrupt. Also note that the ADC is capable of sampling the input voltage supply.

24.2 Features

- Voltage supply monitoring
- Scalable V_{DD} in 64 steps selectable as positive comparator input
- Internal 1.25 V bandgap reference
- Low power mode for internal V_{DD} and bandgap references
- Selectable hysteresis
 - 0 or ± 20 mV
- Selectable response time
- Asynchronous interrupt generation on selectable edges
 - Rising edge
 - Falling edge
 - Rising and Falling edges
- Operational in EM0-EM3
- Comparator output direct on PRS
- Configurable output when inactive to avoid unwanted interrupts

24.3 Functional Description

An overview of the VCMP is shown in Figure 24.1 (p. 334) .

Figure 24.1. VCMP Overview

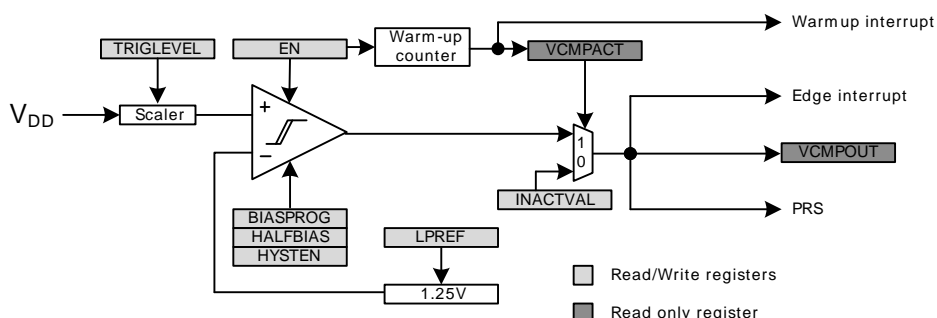

The comparator has two analog inputs, one positive and one negative. When the comparator is active, the output indicates which of the two input voltages is higher. When the voltage on the positive input is higher than the negative input voltage, the digital output is high and vice versa.

The output of the comparator can be read in the VCMPOUT bit in VCMP_STATUS. Configuration registers should only be changed while the comparator is disabled.

24.3.1 Warm-up Time

VCMP is enabled by setting the EN bit in VCMP_CTRL. When this bit is set, the comparator must stabilize before becoming active and the outputs can be used. This time period is called the warm-up time. The warm-up time is a configurable number of HFPERCLK cycles, set in WARMTIME, which should be set to at least 10 μ s. When the comparator is enabled and warmed up, the VCMPACT bit in VCMP_STATUS will be set to indicate that the comparator is active.

As long as the comparator is not enabled or not warmed up, VCMPACT will be cleared and the comparator output value is set to the value in INACTVAL in VCMP_CTRL.

One should wait until the warm-up period is over before entering EM2 or EM3, otherwise no comparator interrupts will be detected. EM1 can still be entered during warm-up. After the warm-up period is completed, interrupts will be detected in EM2 and EM3.

24.3.2 Response Time

There is a delay from when the actual input voltage changes polarity, to when the output toggles. This period is called the response time and can be altered by increasing or decreasing the bias current to the comparator through the BIAS and HALFBIAS fields in VCMP_CTRL as shown in Table 24.1 (p. 334) . Setting a lower bias current will result in lower power consumption, but a longer response time.

Table 24.1. Bias Configuration

BIAS	Bias Current (μ A)	
	HALFBIAS=0	HALFBIAS=1
0b0000	0.1	0.05
0b0001	0.2	0.1
0b0010	0.4	0.2
0b0011	0.6	0.3
0b0100	0.8	0.4
0b0101	1.0	0.5

BIAS	Bias Current (µA)	
	HALFBIAS=0	HALFBIAS=1
0b0110	1.2	0.6
0b0111	1.4	0.7
0b1000	2.0	1.0
0b1001	2.2	1.1
0b1010	2.4	1.2
0b1011	2.6	1.3
0b1100	2.8	1.4
0b1101	3.0	1.5
0b1110	3.2	1.6
0b1111	3.4	1.7

24.3.3 Hysteresis

In the voltage supply comparator, hysteresis can be enabled by setting HYSTEN in VCMP_CTRL. When HYSTEN is set, the digital output will not toggle until the positive input voltage is at least 20mV above or below the negative input voltage. This feature can be used to filter out uninteresting input fluctuations around zero and only show changes that are big enough to breach the hysteresis threshold.

Figure 24.2. VCMP 20 mV Hysteresis Enabled

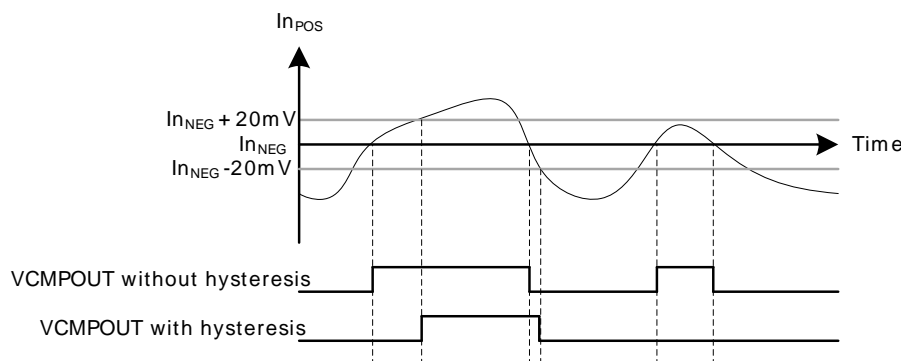

24.3.4 Input Selection

The positive comparator input is always connected to the scaled power supply input. The negative comparator input is connected to the internal 1.25 V bandgap reference. The V_{DD} trigger level can be configured by setting the TRIGLEVEL field in VCMP_CTRL according to the following formula:

VCMP V_{DD} Trigger Level

$$V_{DD} \text{ Trigger Level} = 1.667V + 0.034V \times \text{TRIGLEVEL} \tag{24.1}$$

A low power reference mode can be enabled by setting the LPREF bit in VCMP_INPUTSEL. In this mode, the power consumption in the reference buffer (V_{DD} and bandgap) is lowered at the cost of accuracy.

24.3.5 Interrupts and PRS Output

The VCMP includes an edge triggered interrupt flag (EDGE in VCMP_IF). If either IRISE and/or IFALL in VCMPn_CTRL is set, the EDGE interrupt flag will be set on rising and/or falling edge of the comparator

output respectively. An interrupt request will be sent if the EDGE interrupt flag in VCMP_IF is set and enabled through the EDGE bit in VCMPn_IEN. The edge interrupt can also be used to wake up the device from EM3-EM1. VCMP also includes an interrupt flag, WARMUP in VCMP_IF, which is set when a warm-up sequence has finished. An interrupt request will be sent if the WARMUP interrupt flag in VCMP_IF is set and enabled through the WARMUP bit in VCMPn_IEN. The synchronized comparator output is also available as a PRS output signal.

24.4 Register Map

The offset register address is relative to the registers base address.

Offset	Name	Type	Description
0x000	VCMP_CTRL	RW	Control Register
0x004	VCMP_INPUTSEL	RW	Input Selection Register
0x008	VCMP_STATUS	R	Status Register
0x00C	VCMP_IEN	RW	Interrupt Enable Register
0x010	VCMP_IF	R	Interrupt Flag Register
0x014	VCMP_IFS	W1	Interrupt Flag Set Register
0x018	VCMP_IFC	W1	Interrupt Flag Clear Register

24.5 Register Description

24.5.1 VCMP_CTRL - Control Register

Offset	Bit Position																																
0x000	31	30	29	28	27	26	25	24	23	22	21	20	19	18	17	16	15	14	13	12	11	10	9	8	7	6	5	4	3	2	1	0	
Reset		1				0x7									0	0							0x0						0		0		0
Access		RW				RW									RW	RW							RW						RW		RW		RW
Name		HALFBIAS				BIASPROG									IFALL	IRISE							WARMTIME						HYSTEN		INACTVAL		EN

Bit	Name	Reset	Access	Description
31	Reserved	To ensure compatibility with future devices, always write bits to 0. More information in Section 2.1 (p. 3)		
30	HALFBIAS	1	RW	Half Bias Current Set this bit to 1 to halve the bias current. Table 24.1 (p. 334) .
29:28	Reserved	To ensure compatibility with future devices, always write bits to 0. More information in Section 2.1 (p. 3)		
27:24	BIASPROG	0x7	RW	VCMP Bias Programming Value These bits control the bias current level. Table 24.1 (p. 334) .
23:18	Reserved	To ensure compatibility with future devices, always write bits to 0. More information in Section 2.1 (p. 3)		
17	IFALL	0	RW	Falling Edge Interrupt Sense Set this bit to 1 to set the EDGE interrupt flag on falling edges of comparator output.
16	IRISE	0	RW	Rising Edge Interrupt Sense Set this bit to 1 to set the EDGE interrupt flag on rising edges of comparator output.
15:11	Reserved	To ensure compatibility with future devices, always write bits to 0. More information in Section 2.1 (p. 3)		
10:8	WARMTIME	0x0	RW	Warm-Up Time Set warm-up time
	Value	Mode	Description	
	0	4CYCLES	4 HFPERCLK cycles	
	1	8CYCLES	8 HFPERCLK cycles	
	2	16CYCLES	16 HFPERCLK cycles	
	3	32CYCLES	32 HFPERCLK cycles	
	4	64CYCLES	64 HFPERCLK cycles	
	5	128CYCLES	128 HFPERCLK cycles	
	6	256CYCLES	256 HFPERCLK cycles	

Bit	Name	Reset	Access	Description
	Value	Mode		Description
	7	512CYCLES		512 HFPERCLK cycles
7:5	<i>Reserved</i> To ensure compatibility with future devices, always write bits to 0. More information in Section 2.1 (p. 3)			
4	HYSTEN	0	RW	Hysteresis Enable Enable hysteresis.
	Value	Description		
	0	No hysteresis		
	1	+20 mV hysteresis		
3	<i>Reserved</i> To ensure compatibility with future devices, always write bits to 0. More information in Section 2.1 (p. 3)			
2	INACTVAL	0	RW	Inactive Value Configure the output value when the comparator is inactive.
1	<i>Reserved</i> To ensure compatibility with future devices, always write bits to 0. More information in Section 2.1 (p. 3)			
0	EN	0	RW	Voltage Supply Comparator Enable Enable/disable voltage supply comparator.

24.5.2 VCMP_INPUTSEL - Input Selection Register

Offset	Bit Position																															
0x004	31	30	29	28	27	26	25	24	23	22	21	20	19	18	17	16	15	14	13	12	11	10	9	8	7	6	5	4	3	2	1	0
Reset																								0				0x00				
Access																								RW				RW				
Name																								LPREF				TRIGLEVEL				

Bit	Name	Reset	Access	Description
31:9	<i>Reserved</i> To ensure compatibility with future devices, always write bits to 0. More information in Section 2.1 (p. 3)			
8	LPREF	0	RW	Low Power Reference Enable/disable low power mode for VDD and bandgap reference. When using this bit, always leave it as 0 during warm-up and then set it to 1 if desired when the warm-up is done.
7:6	<i>Reserved</i> To ensure compatibility with future devices, always write bits to 0. More information in Section 2.1 (p. 3)			
5:0	TRIGLEVEL	0x00	RW	Trigger Level Select VDD trigger level. $V_{trig} = 1.667V + 0.034V \times TRIGLEVEL$.

24.5.3 VCMP_STATUS - Status Register

Offset	Bit Position																															
0x008	31	30	29	28	27	26	25	24	23	22	21	20	19	18	17	16	15	14	13	12	11	10	9	8	7	6	5	4	3	2	1	0
Reset																														0	0	
Access																														R	R	
Name																														VCMPOUT	VCMPACT	

Bit	Name	Reset	Access	Description
31:2	Reserved	To ensure compatibility with future devices, always write bits to 0. More information in Section 2.1 (p. 3)		
1	VCMPOUT	0	R	Voltage Supply Comparator Output Voltage supply comparator output value
0	VCMPACT	0	R	Voltage Supply Comparator Active Voltage supply comparator active status.

24.5.4 VCMP_IEN - Interrupt Enable Register

Offset	Bit Position																															
0x00C	31	30	29	28	27	26	25	24	23	22	21	20	19	18	17	16	15	14	13	12	11	10	9	8	7	6	5	4	3	2	1	0
Reset																											0	0				
Access																											RW	RW				
Name																											WARMUP	EDGE				

Bit	Name	Reset	Access	Description
31:2	Reserved	To ensure compatibility with future devices, always write bits to 0. More information in Section 2.1 (p. 3)		
1	WARMUP	0	RW	Warm-up Interrupt Enable Enable/disable interrupt on finished warm-up.
0	EDGE	0	RW	Edge Trigger Interrupt Enable Enable/disable edge triggered interrupt.

24.5.5 VCMP_IF - Interrupt Flag Register

Offset	Bit Position																															
0x010	31	30	29	28	27	26	25	24	23	22	21	20	19	18	17	16	15	14	13	12	11	10	9	8	7	6	5	4	3	2	1	0
Reset																											0	0				
Access																											R	R				
Name																											WARMUP	EDGE				

Bit	Name	Reset	Access	Description
31:2	Reserved	To ensure compatibility with future devices, always write bits to 0. More information in Section 2.1 (p. 3)		
1	WARMUP	0	R	Warm-up Interrupt Flag Indicates that warm-up has finished.
0	EDGE	0	R	Edge Triggered Interrupt Flag Indicates that there has been a rising and/or falling edge on the VCMP output.

24.5.6 VCMP_IFS - Interrupt Flag Set Register

Offset	Bit Position																															
0x014	31	30	29	28	27	26	25	24	23	22	21	20	19	18	17	16	15	14	13	12	11	10	9	8	7	6	5	4	3	2	1	0
Reset																											0	1	0			
Access																											W1	W1	W1			
Name																											WARMUP	EDGE				

Bit	Name	Reset	Access	Description
31:2	Reserved	To ensure compatibility with future devices, always write bits to 0. More information in Section 2.1 (p. 3)		
1	WARMUP	0	W1	Warm-up Interrupt Flag Set Write to 1 to set warm-up finished interrupt flag
0	EDGE	0	W1	Edge Triggered Interrupt Flag Set Write to 1 to set edge triggered interrupt flag

24.5.7 VCMP_IFC - Interrupt Flag Clear Register

Offset	Bit Position																															
0x018	31	30	29	28	27	26	25	24	23	22	21	20	19	18	17	16	15	14	13	12	11	10	9	8	7	6	5	4	3	2	1	0
Reset																											0	1	0			
Access																											W1	W1	W1			
Name																											WARMUP	EDGE				

Bit	Name	Reset	Access	Description
31:2	Reserved	To ensure compatibility with future devices, always write bits to 0. More information in Section 2.1 (p. 3)		
1	WARMUP	0	W1	Warm-up Interrupt Flag Clear Write to 1 to clear warm-up finished interrupt flag
0	EDGE	0	W1	Edge Triggered Interrupt Flag Clear Write to 1 to clear edge triggered interrupt flag

25 ADC - Analog to Digital Converter

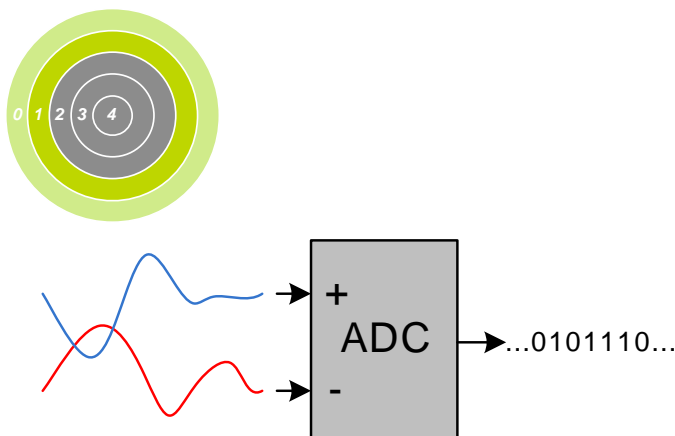

Quick Facts

What?

The ADC is used to convert analog signals into a digital representation and features 8 external input channels

Why?

In many applications there is a need to measure analog signals and record them in a digital representation, without exhausting your energy source.

How?

A low power Successive Approximation Register ADC samples up to 8 input channels in a programmable sequence. With the help of PRS and DMA, the ADC can operate without CPU intervention, minimizing the number of powered up resources. The ADC can further be duty-cycled to reduce the energy consumption.

25.1 Introduction

The ADC is a Successive Approximation Register (SAR) architecture, with a resolution of up to 12 bits at up to one million samples per second. The integrated input mux can select inputs from 8 external pins and 6 internal signals.

25.2 Features

- Programmable resolution (6/8/12-bit)
 - 13 prescaled clock (ADC_CLK) cycles per conversion
 - Maximum 1 MSPS @ 12-bit
 - Maximum 1.86 MSPS @ 6-bit
- Configurable acquisition time
- Integrated prescaler
 - Selectable clock division factor from 1 to 128
- 13 MHz to 32 kHz allowed for ADC_CLK
- 18 input channels
 - 8 external single ended channels
 - 6 internal single ended channels
 - Including temperature sensor
 - 4 external differential channels
- Integrated input filter
 - Low pass RC filter
 - Decoupling capacitor
- Left or right adjusted results
 - Results in 2's complement representation
 - Differential results sign extended to 32-bit results

- Programmable scan sequence
 - Up to 8 configurable samples in scan sequence
 - Mask to select which pins are included in the sequence
 - Triggered by software or PRS input
 - One shot or repetitive mode
 - Oversampling available
 - Overflow interrupt flag set when overwriting unread results
 - Conversion tailgating support for predictable periodic scans
- Programmable single conversion
 - Triggered by software or PRS input
 - Can be interleaved between two scan sequences
 - One shot or repetitive mode
 - Oversampling available
 - Overflow interrupt flag set when overwriting unread results
- Hardware oversampling support
 - 1st order accumulate and dump filter
 - From 2 to 4096 oversampling ratio (OSR)
 - Results in 16-bit representation
 - Enabled individually for scan sequence and single sample mode
 - Common OSR select
- Individually selectable voltage reference for scan and single mode
 - Internal 1.25V reference
 - Internal 2.5V reference
 - V_{DD}
 - Internal 5 V differential reference
 - Single ended external reference
 - Differential external reference
 - Unbuffered $2 \times V_{DD}$
- Support for offset and gain calibration
- Interrupt generation and/or DMA request
 - Finished single conversion
 - Finished scan conversion
 - Single conversion results overflow
 - Scan sequence results overflow
- Loopback configuration with DAC output measurement

25.3 Functional Description

An overview of the ADC is shown in Figure 25.1 (p. 343) .

Figure 25.1. ADC Overview

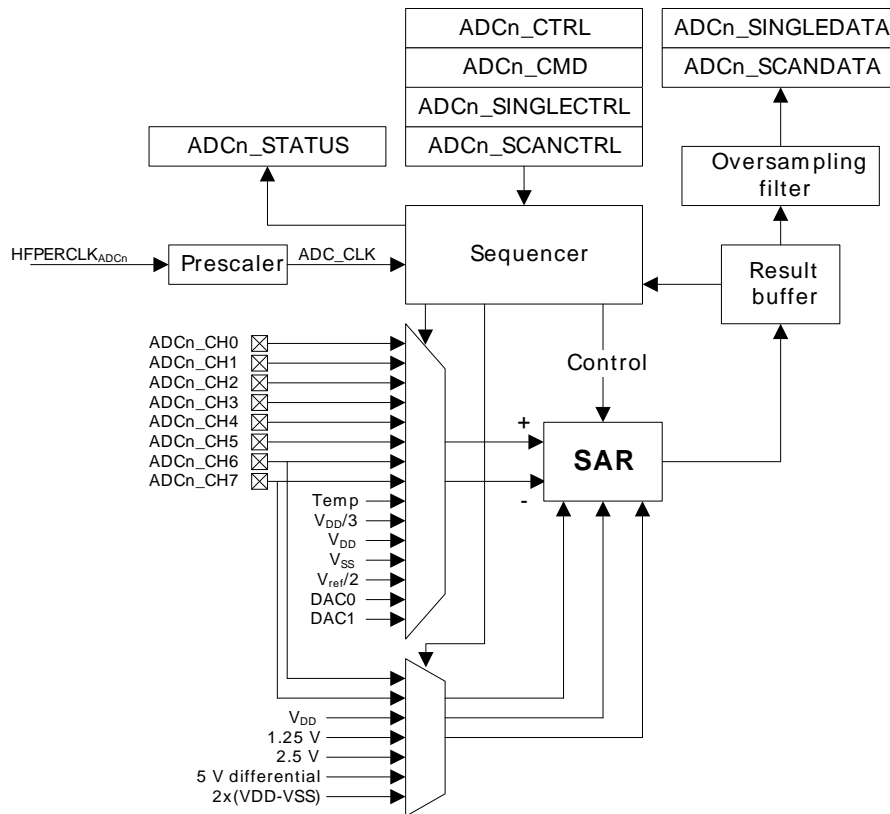

25.3.1 Clock Selection

The ADC has an internal prescaler (PRESC bits in ADCn_CTRL) which can divide the peripheral clock (HPPERCLK) by any factor between 1 and 128. Note that the resulting ADC_CLK should not be set to a higher frequency than 13 MHz and not lower than 32 kHz.

25.3.2 Conversions

A conversion consists of two phases. The input is sampled in the acquisition phase before it is converted to digital representation during the approximation phase. The acquisition time can be configured independently for scan and single conversions (see Section 25.3.7 (p. 347)) by setting AT in ADCn_SINGLECTRL/ADCn_SCANCTRL. The acquisition times can be set to any integer power of 2 from 1 to 256 ADC_CLK cycles.

Note

For high impedance sources the acquisition time should be adjusted to allow enough time for the internal sample capacitor to fully charge. The minimum acquisition time for the internal temperature sensor and V_{DD}/3 is given in the electrical characteristics for the device.

The analog to digital converter core uses one clock cycle per output bit in the approximation phase.

ADC Total Conversion Time (in ADC_CLK cycles) Per Output

$$T_{conv} = (T_A + N) \times OSR \tag{25.1}$$

T_A equals the number of acquisition cycles and N is the resolution. OSR is the oversampling ratio (see Section 25.3.7.7 (p. 349)). The minimum conversion time is 7 ADC_CYCLES with 6 bit resolution and 13 ADC_CYCLES with 12 bit resolution. The maximum conversion time is 1097728 ADC_CYCLES with the longest acquisition time, 12 bit resolution and highest oversampling rate.

Figure 25.2. ADC Conversion Timing

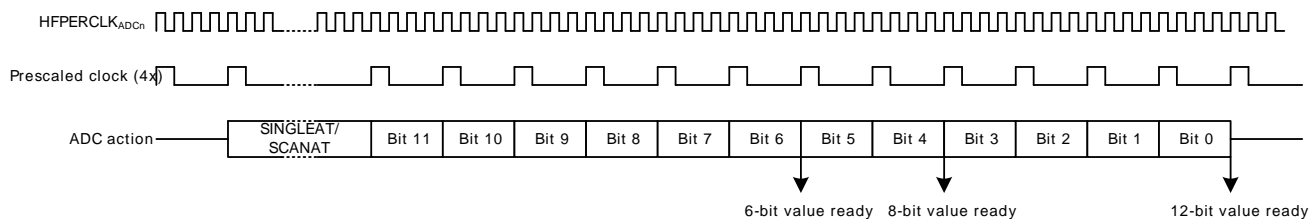

25.3.3 Warm-up Time

The ADC needs to be warmed up some time before a conversion can take place. This time period is called the warm-up time. When enabling the ADC or changing references between samples, the ADC is automatically warmed up for 1µs and an additional 5 µs if the bandgap is selected as reference.

Normally, the ADC will be warmed up only when samples are requested and is shut off when there are no more samples waiting. However, if lower latency is needed, configuring the WARMUPMODE field in ADCn_CTRL allows the ADC and/or reference to stay warm between samples, eliminating the need for warm-up. Figure 25.3 (p. 345) shows the analog power consumption in scenarios using the different WARMUPMODE settings.

Only the bandgap reference selected for scan mode can be kept warm. If a different bandgap reference is selected for single mode, the warm-up time still applies.

- **NORMAL**: ADC and references are shut off when there are no samples waiting. a) in Figure 25.3 (p. 345) shows this mode used with an internal bandgap reference. Figure d) shows this mode when using VDD or an external reference.
- **FASTBG**: Bandgap warm-up is eliminated, but with reduced reference accuracy. d) in Figure 25.3 (p. 345) shows this mode used with an internal bandgap reference.
- **KEEPSCANREFWARM**: The reference selected for scan mode is kept warm. The ADC will still need to be warmed up before conversion. b) in Figure 25.3 (p. 345) shows this mode used with an internal bandgap reference.
- **KEEPADCWARM**: The ADC and the reference selected for scan mode is kept warm. c) in Figure 25.3 (p. 345) shows this mode used with an internal bandgap reference.

The minimum warm-up times are given in µs. The timing is done automatically by the ADC, given that a proper time base is given in the TIMEBASE bits in ADCn_CTRL. The TIMEBASE must be set to the number of HPPERCLK which corresponds to at least 1 µs. The TIMEBASE only affects the timing of the warm-up sequence and not the ADC_CLK.

When entering Energy Modes 2 or 3, the ADC must be stopped and WARMUPMODE in ADCn_CTRL written to 0.

Figure 25.3. ADC Analog Power Consumption With Different WARMUPMODE Settings

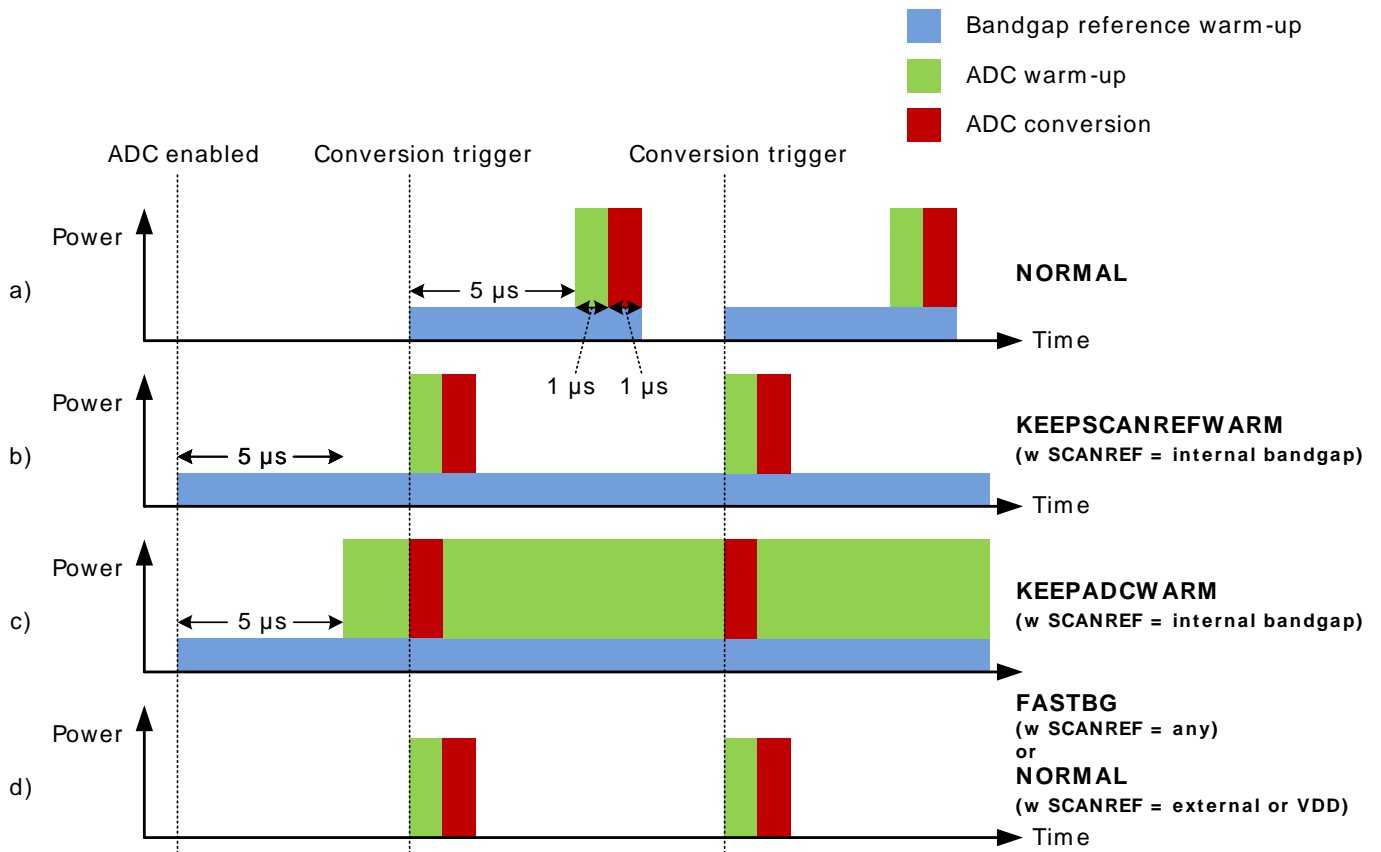

25.3.4 Input Selection

The ADC is connected to 8 external input pins, which can be selected as 8 different single ended inputs or 4 differential inputs. In addition, 6 single ended internal inputs can be selected. The available selections are given in the register description for ADCn_SINGLECTRL and ADCn_SCANCTRL.

For offset calibration purposes it is possible to internally short the differential ADC inputs and thereby measure a 0 V differential. Differential 0 V is selected by writing the DIFF bit to 1 and INPUTSEL to 4 in ADCn_SINGLECTRL. Calibration is described in detail in Section 25.3.10 (p. 350) .

Note

When VDD/3 is sampled, the acquisition time should be above a lower limit. The reader is referred to the datasheet for minimum VDD/3 acquisition time.

25.3.4.1 Input Filtering

The selected input signal can be filtered, either through an internal low pass RC filter or an internal decoupling capacitor. The different filter configurations can be enabled through the LPFMODE bits in ADCn_CTRL.

The RC input filter configuration is given in Figure 25.4 (p. 345). The resistance and capacitance values are given in the electrical characteristics for the device, named R_{ADCFILT} and C_{ADCFILT} respectively.

Figure 25.4. ADC RC Input Filter Configuration

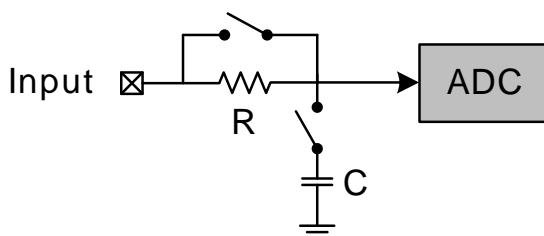

25.3.4.2 Temperature Measurement

The ADC includes an internal temperature sensor. This sensor is characterized during production and the temperature readout from the ADC at production temperature, ADC0_TEMP_0_READ_1V25, is given in the Device Information (DI) page. The production temperature, CAL_TEMP_0, is also given in this page. The temperature gradient, TGRAD_ADCTH (mV/degree Celsius), for the sensor is found in the datasheet for the devices. By selecting 1.25 V internal reference and measuring the internal temperature sensor with 12 bit resolution, the temperature can be calculated according to the following formula:

ADC Temperature Measurement

$$T_{\text{CELSIUS}} = \text{CAL_TEMP_0} - (\text{ADC0_TEMP_0_READ_1V25} - \text{ADC_result}) \times V_{\text{ref}} / (4096 \times \text{TGRAD_ADCTH}) \quad (25.2)$$

Note

The minimum acquisition time for the temperature reference is found in the electrical characteristics for the device.

25.3.5 Reference Selection

The reference voltage can be selected from these sources:

- 1.25 V internal bandgap
- 2.5 V internal bandgap
- V_{DD}
- 5 V internal differential bandgap
- External single ended input from pin 6
- Differential input, 2x(pin 6 - pin 7)
- Unbuffered $2 \times V_{\text{DD}}$

- The 2.5 V reference needs a supply voltage higher than 2.5 V.
- The differential 5 V reference needs a supply voltage higher than 2.75 V.

Since the $2 \times V_{\text{DD}}$ differential reference is unbuffered, it is directly connected to the ADC supply voltage and more susceptible to supply noise. The V_{DD} reference is buffered both in single ended and differential mode.

If a differential reference with a larger range than the supply voltage is combined with single ended measurements, for instance the 5 V internal reference, the full ADC range will not be available because the maximum input voltage is limited by the maximum electrical ratings.

Note

Single ended measurements with the external differential reference are not supported.

25.3.6 Programming of Bias Current

The bias current of the bandgap reference and the ADC comparator can be scaled by the BIASPROG, HALFBIAS and COMPBIAS bit fields of the ADCn_BIASPROG register. The BIASPROG and HALFBIAS bitfields scale the current of ADC bandgap reference, and the COMPBIAS bits provide an additional bias programming for the ADC comparator as illustrated in Figure 25.5 (p. 347). The electrical characteristics given in the datasheet require the bias configuration to be set to the default values, where no other bias values are given.

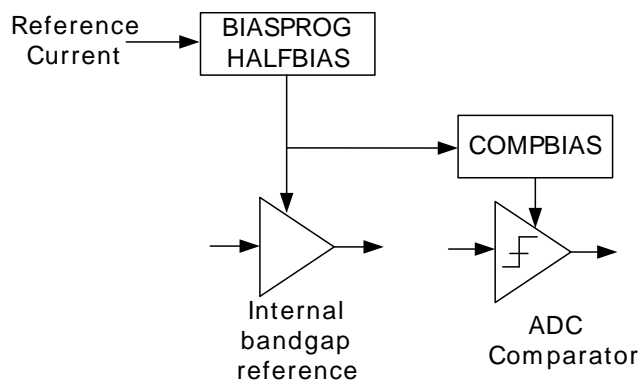
Figure 25.5. ADC Bias Programming

The minimum value of the BIASPROG and COMPBIAS bitfields of the ADCn_BIASPROG register (i.e. BIASPROG=0b0000, COMPBIAS=0b0000) represent the minimum bias currents. Similarly BIASPROG=0b1111 and COMPBIAS=0b1111 represent the maximum bias currents. Additionally, the bias current defined by the BIASPROG setting can be halved by setting the HALFBIAS bit of the ADCn_BIASPROG register.

The bias current settings should only be changed while the ADC is disabled.

25.3.7 ADC Modes

The ADC contains two separate programmable modes, one single sample mode and one scan mode. Both modes have separate configuration and result registers and can be set up to run only once per trigger or repetitively. The scan mode has priority over the single sample mode. However, if scan sequence is running, a triggered single sample will be interleaved between two scan samples.

25.3.7.1 Single Sample Mode

The single sample mode can be used to convert a single sample either once per trigger or repetitively. The configuration of the single sample mode is done in the ADCn_SINGLECTRL register and the results are found in the ADCn_SINGLEDATA register. The SINGLEDV bit in ADCn_STATUS is set high when there is valid data in the result register and is cleared when the data is read. The single mode results can also be read through ADCn_SINGLEDATAP without SINGLEDV being cleared. DIFF in ADCn_SINGLECTRL selects whether differential or single ended inputs are used and INPUTSEL selects input pin(s).

25.3.7.2 Scan mode

The scan mode is used to perform sweeps of the inputs. The configuration of the scan sequence is done in the ADCn_SCANCTRL register and the results are found in the ADCn_SCANDATA register. The SCANDV bit in ADCn_STATUS is set high when there is valid data in the result register and is cleared when the data is read. The scan mode results can also be read through ADCn_SCANDATAP without SCANDV being cleared. The inputs included in the sequence are defined by a the mask in INPUTMASK in ADCn_SCANCTRL. When the scan sequence is triggered, the sequence samples all inputs that are included in the mask, starting at the lowest pin number. DIFF in ADCn_SCANCTRL selects whether single ended or differential inputs are used.

25.3.7.3 Conversion Tailgating

The scan sequence has priority over the single sample mode. However, a scan trigger will not interrupt in the middle of a single conversion. If a scan sequence is triggered by a timer on a periodic basis, single sample just before a scan trigger can delay the start of the scan sequence, thus causing jitter in sample rate. To solve this, conversion tailgating can be chosen by setting TAILGATE in ADCn_CTRL. When this bit is set, any triggered single samples will wait for the next scan sequence to finish before

activating (see Figure 25.6 (p. 348)). The single sample will then follow immediately after the scan sequence. In this way, the scan sequence will always start immediately when triggered, if the period between the scan triggers is big enough to allow any single samples that might be triggered to finish in between the scan sequences.

Figure 25.6. ADC Conversion Tailgating

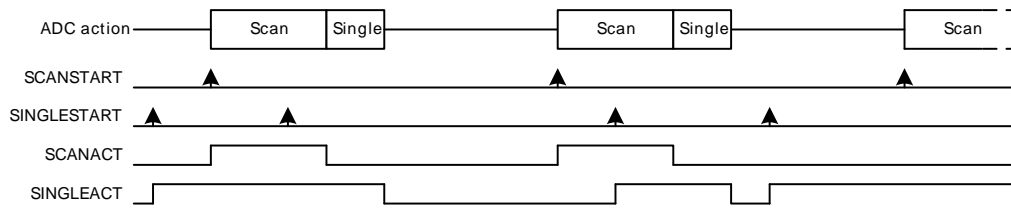

25.3.7.4 Conversion Trigger

The conversion modes can be activated by writing a 1 to the SINGLESTART or SCANSTART bit in the ADCn_CMD register. The conversions can be stopped by writing a 1 to the SINGLESTOP or SCANSTOP bit in the ADCn_CMD register. A START command will have priority over a stop command. When the ADC is stopped in the middle of a conversion, the result buffer is cleared. The SINGLEACT and SCANACT bits in ADCn_STATUS are set high when the modes are actively converting or have pending conversions.

It is also possible to trigger conversions from PRS signals. The system requires one HPERCLK cycle pulses to trigger conversions. Setting PRSEN in ADCn_SINGLECTRL/ADCn_SCANCTRL enables triggering from PRS input. Which PRS channel to listen to is defined by PRSEL in ADCn_SINGLECTRL/ADCn_SCANCTRL. When PRS trigger is selected, it is still possible to trigger the conversion from software. The reader is referred to the PRS datasheet for more information on how to set up the PRS channels.

Note

The conversion settings should not be changed while the ADC is running as this can lead to unpredictable behavior.

The prescaled clock phase is always reset by a triggered conversion as long as a conversion is not ongoing. This gives predictable latency from the time of the trigger to the time the conversion starts, regardless of when in the prescaled clock cycle the trigger occur.

25.3.7.5 Results

The results are presented in 2's complement form and the format for differential and single ended mode is given in Table 25.1 (p. 348) and Table 25.2 (p. 349) . If differential mode is selected, the results are sign extended up to 32-bit (shown in Table 25.4 (p. 350)).

Table 25.1. ADC Single Ended Conversion

Input/Reference	Results	
	Binary	Hex value
1	111111111111	FFF
0.5	011111111111	7FF
1/4096	000000000001	001
0	000000000000	000

Table 25.2. ADC Differential Conversion

Input/Reference	Results	
	Binary	Hex value
0.5	011111111111	7FF
0.25	001111111111	3FF
1/2048	000000000001	001
0	000000000000	000
-1/2048	111111111111	FFF
-0.25	101111111111	BFF
-0.5	100000000000	800

25.3.7.6 Resolution

The ADC gives out 12-bit results, by default. However, if full 12-bit resolution is not needed, it is possible to speed up the conversion by selecting a lower resolution ($N = 6$ or 8 bits). For more information on the accuracy of the ADC, the reader is referred to the electrical characteristics section for the device.

25.3.7.7 Oversampling

To achieve higher accuracy, hardware oversampling can be enabled individually for each mode (Set RES in ADCn_SINGLECTRL/ADCn_SCANCTRL to 0x3). The oversampling rate (OVSRSEL in ADCn_CTRL) can be set to any integer power of 2 from 2 to 4096 and the configuration is shared between the scan and single sample mode (OVSRSEL field in ADCn_CTRL).

With oversampling, each selected input is sampled a number (given by the OVSR) of times, and the results are filtered by a first order accumulate and dump filter to form the end result. The data presented in the ADCn_SINGLEDATA and ADCn_SCANDATA registers are the direct contents of the accumulation register (sum of samples). However, if the oversampling ratio is set higher than 16x, the accumulated results are shifted to fit the MSB in bit 15 as shown in Table 25.3 (p. 349).

Table 25.3. Oversampling Result Shifting and Resolution

Oversampling setting	# right shifts	Result Resolution # bits
2x	0	13
4x	0	14
8x	0	15
16x	0	16
32x	1	16
64x	2	16
128x	3	16
256x	4	16
512x	5	16
1024x	6	16
2048x	7	16
4096x	8	16

25.3.7.8 Adjustment

By default, all results are right adjusted, with the LSB of the result in bit position 0 (zero). In differential mode the signed bit is extended up to bit 31, but in single ended mode the bits above the result are read as 0. By setting ADJ in ADCn_SINGLECTRL/ADCn_SCANCTRL, the results are left adjusted as shown in Table 25.4 (p. 350) . When left adjusted, the MSB is always placed on bit 15 and sign extended to bit 31. All bits below the conversion result are read as 0 (zero).

Table 25.4. ADC Results Representation

Adjustment	Resolution	Bit																															
		31	30	29	28	27	26	25	24	23	22	21	20	19	18	17	16	15	14	13	12	11	10	9	8	7	6	5	4	3	2	1	0
Right	12	11	11	11	11	11	11	11	11	11	11	11	11	11	11	11	11	11	11	11	11	11	10	9	8	7	6	5	4	3	2	1	0
	8	7	7	7	7	7	7	7	7	7	7	7	7	7	7	7	7	7	7	7	7	7	7	7	7	7	6	5	4	3	2	1	0
	6	5	5	5	5	5	5	5	5	5	5	5	5	5	5	5	5	5	5	5	5	5	5	5	5	5	5	5	4	3	2	1	0
	OVS	15	15	15	15	15	15	15	15	15	15	15	15	15	15	15	15	15	15	14	13	12	11	10	9	8	7	6	5	4	3	2	1
Left	12	11	11	11	11	11	11	11	11	11	11	11	11	11	11	11	11	11	10	9	8	7	6	5	4	3	2	1	0	-	-	-	-
	8	7	7	7	7	7	7	7	7	7	7	7	7	7	7	7	7	6	5	4	3	2	1	0	-	-	-	-	-	-	-	-	-
	6	5	5	5	5	5	5	5	5	5	5	5	5	5	5	5	5	4	3	2	1	0	-	-	-	-	-	-	-	-	-	-	-
	OVS	15	15	15	15	15	15	15	15	15	15	15	15	15	15	15	15	15	15	15	15	15	15	15	15	15	15	15	15	15	15	15	15

25.3.8 Interrupts, PRS Output

The single and scan modes have separate interrupt flags indicating finished conversions. Setting one of these flags will result in an ADC interrupt if the corresponding interrupt enable bit is set in ADCn_IEN.

In addition to the finished conversion flags, there is a scan and single sample result overflow flag which signals that a result from a scan sequence or single sample has been overwritten before being read.

A finished conversion will result in a one HPPERCLK cycle pulse which is output to the Peripheral Reflex System (PRS).

25.3.9 DMA Request

The ADC has two DMA request lines, SINGLE and SCAN, which are set when a single or scan conversion has completed. The request are cleared when the corresponding single or scan result register is read.

25.3.10 Calibration

The ADC supports offset and gain calibration to correct errors due to process and temperature variations. This must be done individually for each reference used. The ADC calibration (ADCn_CAL) register contains four register fields for calibrating offset and gain for both single and scan mode. The gain and offset calibration are done in single mode, but the resulting calibration values can be used for both single and scan mode.

Gain and offset for the 1V25, 2V5 and VDD references are calibrated during production and the calibration values for these can be found in the Device Information page. During reset, the gain and offset calibration registers are loaded with the production calibration values for the 1V25 reference.

The SCANGAIN and SINGLEGAIN calibration fields are not used when the unbuffered differential 2xVDD reference is selected.

The effects of changing the calibration register values are given in Table 25.5 (p. 351) . Step by step calibration procedures for offset and gain are given in Section 25.3.10.1 (p. 351) and Section 25.3.10.2 (p. 351) .

Table 25.5. Calibration Register Effect

Calibration Register	ADC Result	Calibration Binary Value	Calibration Hex Value
Offset	Lowest Output	0111111	3F
	Highest Output	1000000	40
Gain	Lowest Output	0000000	00
	Highest Output	1111111	7F

The offset calibration register expects a signed 2's complement value with negative effect. A high value gives a low ADC reading.

The gain calibration register expects an unsigned value with positive effect. A high value gives a high ADC reading.

25.3.10.1 Offset Calibration

Offset calibration must be performed prior to gain calibration. Follow these steps for the offset calibration in single mode:

1. Select wanted reference by setting the REF bitfield of the ADCn_SINGLECTRL register.
2. Set the AT bitfield of the ADCn_SINGLECTRL register to 16CYCLES.
3. Set the INPUTSEL bitfield of the ADCn_SINGLECTRL register to DIFF0, and set the DIFF bitfield to 1 for enabling differential input. Since the input voltage is 0, the expected ADC output is the half of the ADC code range as it is in differential mode.
4. A binary search is used to find the offset calibration value. Set the SINGLESTART bit in the ADCn_CTRL register and read the ADCn_SINGLEDATA register. The result of the binary search is written to the SINGLEOFFSET field of the ADCn_CAL register.

25.3.10.2 Gain Calibration

Offset calibration must be performed prior to gain calibration. The Gain Calibration is done in the following manner:

1. Select an external ADC channel (a differential channel can also be used).
2. Apply an external voltage on the selected ADC input channel. This voltage should correspond to the top of the ADC range.
3. A binary search is used to find the gain calibration value. Set the SINGLESTART bit in the ADCn_CTRL register and read the ADCn_SINGLEDATA register. The target value is ideally the top of the ADC range, but it is recommended to use a value a couple of LSBs below in order to avoid overshooting. The result of the binary search is written to the SINGLEGAIN field of the ADCn_CAL register.

25.4 Register Map

The offset register address is relative to the registers base address.

Offset	Name	Type	Description
0x000	ADCn_CTRL	RW	Control Register
0x004	ADCn_CMD	W1	Command Register
0x008	ADCn_STATUS	R	Status Register
0x00C	ADCn_SINGLECTRL	RW	Single Sample Control Register
0x010	ADCn_SCANCTRL	RW	Scan Control Register
0x014	ADCn_IEN	RW	Interrupt Enable Register
0x018	ADCn_IF	R	Interrupt Flag Register
0x01C	ADCn_IFS	W1	Interrupt Flag Set Register
0x020	ADCn_IFC	W1	Interrupt Flag Clear Register
0x024	ADCn_SINGLEDATA	R	Single Conversion Result Data
0x028	ADCn_SCANDATA	R	Scan Conversion Result Data
0x02C	ADCn_SINGLEDATAP	R	Single Conversion Result Data Peek Register
0x030	ADCn_SCANDATAP	R	Scan Sequence Result Data Peek Register
0x034	ADCn_CAL	RW	Calibration Register
0x03C	ADCn_BIASPROG	RW	Bias Programming Register

25.5 Register Description

25.5.1 ADCn_CTRL - Control Register

Offset	Bit Position																																
	31	30	29	28	27	26	25	24	23	22	21	20	19	18	17	16	15	14	13	12	11	10	9	8	7	6	5	4	3	2	1	0	
0x000																																	
Reset						0x0								0x1F														0x0		0			0x0
Access						RW								RW														RW	RW			RW	
Name						OVSRSSEL								TIMEBASE														LPFMODE	TAILGATE			WARMUPMODE	

Bit	Name	Reset	Access	Description
31:28	Reserved	To ensure compatibility with future devices, always write bits to 0. More information in Section 2.1 (p. 3)		

27:24 OVSRSSEL 0x0 RW **Oversample Rate Select**

Select oversampling rate. Oversampling must be enabled for each mode for this setting to take effect.

Value	Mode	Description
0	X2	2 samples for each conversion result
1	X4	4 samples for each conversion result
2	X8	8 samples for each conversion result
3	X16	16 samples for each conversion result
4	X32	32 samples for each conversion result
5	X64	64 samples for each conversion result
6	X128	128 samples for each conversion result
7	X256	256 samples for each conversion result
8	X512	512 samples for each conversion result

Bit	Name	Reset	Access	Description
31:4	Reserved	To ensure compatibility with future devices, always write bits to 0. More information in Section 2.1 (p. 3)		
3	SCANSTOP	0	W1	Scan Sequence Stop Write a 1 to stop scan sequence.
2	SCANSTART	0	W1	Scan Sequence Start Write a 1 to start scan sequence.
1	SINGLESTOP	0	W1	Single Conversion Stop Write a 1 to stop single conversion.
0	SINGLESTART	0	W1	Single Conversion Start Write to 1 to start single conversion.

25.5.3 ADCn_STATUS - Status Register

Offset	Bit Position																																
	31	30	29	28	27	26	25	24	23	22	21	20	19	18	17	16	15	14	13	12	11	10	9	8	7	6	5	4	3	2	1	0	
0x008							0x0								0	0								0	0							0	0
Reset							0x0								0	0								0	0							0	0
Access							R								R	R								R	R							R	R
Name							SCANDATASRC								SCANDV	SINGLEDV																SCANACT	SINGLEACT

Bit	Name	Reset	Access	Description
31:27	Reserved	To ensure compatibility with future devices, always write bits to 0. More information in Section 2.1 (p. 3)		

26:24	SCANDATASRC	0x0	R	Scan Data Source
-------	-------------	-----	---	-------------------------

This value indicates from which input channel the results in the ADCn_SCANDATA register originates.

Value	Mode	Description
0	CH0	Single ended mode: SCANDATA result originates from ADCn_CH0. Differential mode: SCANDATA result originates from ADCn_CH0-ADCn_CH1
1	CH1	Single ended mode: SCANDATA result originates from ADCn_CH1. Differential mode: SCANDATA result originates from ADCn_CH2-ADCn_CH3
2	CH2	Single ended mode: SCANDATA result originates from ADCn_CH2. Differential mode: SCANDATA result originates from ADCn_CH4-ADCn_CH5
3	CH3	Single ended mode: SCANDATA result originates from ADCn_CH3. Differential mode: SCANDATA result originates from ADCn_CH6-ADCn_CH7
4	CH4	SCANDATA result originates from ADCn_CH4
5	CH5	SCANDATA result originates from ADCn_CH5
6	CH6	SCANDATA result originates from ADCn_CH6
7	CH7	SCANDATA result originates from ADCn_CH7

23:18	Reserved	To ensure compatibility with future devices, always write bits to 0. More information in Section 2.1 (p. 3)		
-------	----------	---	--	--

17	SCANDV	0	R	Scan Data Valid Scan conversion data is valid.
----	--------	---	---	--

16	SINGLEDV	0	R	Single Sample Data Valid Single conversion data is valid.
----	----------	---	---	---

15:13	Reserved	To ensure compatibility with future devices, always write bits to 0. More information in Section 2.1 (p. 3)		
-------	----------	---	--	--

12	WARM	0	R	ADC Warmed Up ADC is warmed up.
----	------	---	---	---

11:10	Reserved	To ensure compatibility with future devices, always write bits to 0. More information in Section 2.1 (p. 3)		
-------	----------	---	--	--

9	SCANREFWARM	0	R	Scan Reference Warmed Up
---	-------------	---	---	---------------------------------

Bit	Name	Reset	Access	Description
				Reference selected for scan mode is warmed up.
8	SINGLEREFWARM	0	R	Single Reference Warmed Up Reference selected for single mode is warmed up.
7:2	<i>Reserved</i>	<i>To ensure compatibility with future devices, always write bits to 0. More information in Section 2.1 (p. 3)</i>		
1	SCANACT	0	R	Scan Conversion Active Scan sequence is active or has pending conversions.
0	SINGLEACT	0	R	Single Conversion Active Single conversion is active or has pending conversions.

25.5.4 ADCn_SINGLECTRL - Single Sample Control Register

Offset	Bit Position																																
0x00C	31	30	29	28	27	26	25	24	23	22	21	20	19	18	17	16	15	14	13	12	11	10	9	8	7	6	5	4	3	2	1	0	
Reset			0x0					0			0x0				0x0							0x0						0x0			0	0	0
Access			RW					RW			RW				RW							RW						RW			RW	RW	RW
Name			PRSEL					PRSEN			AT				REF								INPUTSEL					RES			ADJ	DIFF	REP

Bit	Name	Reset	Access	Description
31	<i>Reserved</i>	<i>To ensure compatibility with future devices, always write bits to 0. More information in Section 2.1 (p. 3)</i>		

30:28	PRSEL	0x0	RW	Single Sample PRS Trigger Select Select PRS trigger for single sample.
-------	-------	-----	----	--

Value	Mode	Description
0	PRSCH0	PRS ch 0 triggers single sample
1	PRSCH1	PRS ch 1 triggers single sample
2	PRSCH2	PRS ch 2 triggers single sample
3	PRSCH3	PRS ch 3 triggers single sample
4	PRSCH4	PRS ch 4 triggers single sample
5	PRSCH5	PRS ch 5 triggers single sample
6	PRSCH6	PRS ch 6 triggers single sample
7	PRSCH7	PRS ch 7 triggers single sample

27:25	<i>Reserved</i>	<i>To ensure compatibility with future devices, always write bits to 0. More information in Section 2.1 (p. 3)</i>		
-------	-----------------	--	--	--

24	PRSEN	0	RW	Single Sample PRS Trigger Enable Enabled/disable PRS trigger of single sample.
----	-------	---	----	--

Value	Description
0	Single sample is not triggered by PRS input
1	Single sample is triggered by PRS input selected by PRSEL

23:20	AT	0x0	RW	Single Sample Acquisition Time Select the acquisition time for single sample.
-------	----	-----	----	---

Value	Mode	Description
0	1CYCLE	1 ADC_CLK cycle acquisition time for single sample
1	2CYCLES	2 ADC_CLK cycles acquisition time for single sample
2	4CYCLES	4 ADC_CLK cycles acquisition time for single sample
3	8CYCLES	8 ADC_CLK cycles acquisition time for single sample
4	16CYCLES	16 ADC_CLK cycles acquisition time for single sample
5	32CYCLES	32 ADC_CLK cycles acquisition time for single sample
6	64CYCLES	64 ADC_CLK cycles acquisition time for single sample

Bit	Name	Reset	Access	Description
	Value	Mode		Description
	7	128CYCLES		128 ADC_CLK cycles acquisition time for single sample
	8	256CYCLES		256 ADC_CLK cycles acquisition time for single sample
19	<i>Reserved</i> To ensure compatibility with future devices, always write bits to 0. More information in Section 2.1 (p. 3)			
18:16	REF	0x0	RW	Single Sample Reference Selection
	Select reference to ADC single sample mode.			
	Value	Mode		Description
	0	1V25		Internal 1.25 V reference
	1	2V5		Internal 2.5 V reference
	2	VDD		Buffered VDD
	3	5VDIFF		Internal differential 5 V reference
	4	EXTSINGLE		Single ended external reference from pin 6
	5	2XEXTDIFF		Differential external reference, 2x(pin 6 - pin 7)
	6	2XVDD		Unbuffered 2xVDD
15:12	<i>Reserved</i> To ensure compatibility with future devices, always write bits to 0. More information in Section 2.1 (p. 3)			
11:8	INPUTSEL	0x0	RW	Single Sample Input Selection
	Select input to ADC single sample mode in either single ended mode or differential mode.			
	DIFF = 0			
	Mode	Value		Description
	CH0	0		ADCn_CH0
	CH1	1		ADCn_CH1
	CH2	2		ADCn_CH2
	CH3	3		ADCn_CH3
	CH4	4		ADCn_CH4
	CH5	5		ADCn_CH5
	CH6	6		ADCn_CH6
	CH7	7		ADCn_CH7
	TEMP	8		Temperature reference
	VDDDIV3	9		VDD/3
	VDD	10		VDD
	VSS	11		VSS
	VREFDIV2	12		VREF/2
	DAC0OUT0	13		DAC0 output 0
	DAC0OUT1	14		DAC0 output 1
	DIFF = 1			
	Mode	Value		Description
	CH0CH1	0		Positive input: ADCn_CH0 Negative input: ADCn_CH1
	CH2CH3	1		Positive input: ADCn_CH2 Negative input: ADCn_CH3
	CH4CH5	2		Positive input: ADCn_CH4 Negative input: ADCn_CH5
	CH6CH7	3		Positive input: ADCn_CH6 Negative input: ADCn_CH7
	DIFF0	4		Differential 0 (Short between positive and negative inputs)
7:6	<i>Reserved</i> To ensure compatibility with future devices, always write bits to 0. More information in Section 2.1 (p. 3)			
5:4	RES	0x0	RW	Single Sample Resolution Select
	Select single sample conversion resolution.			
	Value	Mode		Description
	0	12BIT		12-bit resolution
	1	8BIT		8-bit resolution
	2	6BIT		6-bit resolution
	3	OVS		Oversampling enabled. Oversampling rate is set in OVSRSEL
3	<i>Reserved</i> To ensure compatibility with future devices, always write bits to 0. More information in Section 2.1 (p. 3)			

Bit	Name	Reset	Access	Description									
2	ADJ	0	RW	Single Sample Result Adjustment Select single sample result adjustment.									
<table border="1"> <thead> <tr> <th>Value</th> <th>Mode</th> <th>Description</th> </tr> </thead> <tbody> <tr> <td>0</td> <td>RIGHT</td> <td>Results are right adjusted</td> </tr> <tr> <td>1</td> <td>LEFT</td> <td>Results are left adjusted</td> </tr> </tbody> </table>					Value	Mode	Description	0	RIGHT	Results are right adjusted	1	LEFT	Results are left adjusted
Value	Mode	Description											
0	RIGHT	Results are right adjusted											
1	LEFT	Results are left adjusted											
1	DIFF	0	RW	Single Sample Differential Mode Select single ended or differential input.									
<table border="1"> <thead> <tr> <th>Value</th> <th>Description</th> </tr> </thead> <tbody> <tr> <td>0</td> <td>Single ended input</td> </tr> <tr> <td>1</td> <td>Differential input</td> </tr> </tbody> </table>					Value	Description	0	Single ended input	1	Differential input			
Value	Description												
0	Single ended input												
1	Differential input												
0	REP	0	RW	Single Sample Repetitive Mode Enable/disable repetitive single samples.									
<table border="1"> <thead> <tr> <th>Value</th> <th>Description</th> </tr> </thead> <tbody> <tr> <td>0</td> <td>Single conversion mode is deactivated after one conversion</td> </tr> <tr> <td>1</td> <td>Single conversion mode is converting continuously until SINGLESTOP is written</td> </tr> </tbody> </table>					Value	Description	0	Single conversion mode is deactivated after one conversion	1	Single conversion mode is converting continuously until SINGLESTOP is written			
Value	Description												
0	Single conversion mode is deactivated after one conversion												
1	Single conversion mode is converting continuously until SINGLESTOP is written												

25.5.5 ADCn_SCANCTRL - Scan Control Register

Offset	Bit Position																																
0x010	31	30	29	28	27	26	25	24	23	22	21	20	19	18	17	16	15	14	13	12	11	10	9	8	7	6	5	4	3	2	1	0	
Reset			0x0				0			0x0				0x0							0x00							0x0			0	0	0
Access			RW				RW			RW				RW							RW							RW			RW	RW	RW
Name			PRSEL				PRSEN			AT				REF							INPUTMASK							RES			ADJ	DIFF	REP

Bit	Name	Reset	Access	Description																											
31	Reserved	To ensure compatibility with future devices, always write bits to 0. More information in Section 2.1 (p. 3)																													
30:28	PRSEL	0x0	RW	Scan Sequence PRS Trigger Select Select PRS trigger for scan sequence.																											
<table border="1"> <thead> <tr> <th>Value</th> <th>Mode</th> <th>Description</th> </tr> </thead> <tbody> <tr> <td>0</td> <td>PRSCH0</td> <td>PRS ch 0 triggers scan sequence</td> </tr> <tr> <td>1</td> <td>PRSCH1</td> <td>PRS ch 1 triggers scan sequence</td> </tr> <tr> <td>2</td> <td>PRSCH2</td> <td>PRS ch 2 triggers scan sequence</td> </tr> <tr> <td>3</td> <td>PRSCH3</td> <td>PRS ch 3 triggers scan sequence</td> </tr> <tr> <td>4</td> <td>PRSCH4</td> <td>PRS ch 4 triggers scan sequence</td> </tr> <tr> <td>5</td> <td>PRSCH5</td> <td>PRS ch 5 triggers scan sequence</td> </tr> <tr> <td>6</td> <td>PRSCH6</td> <td>PRS ch 6 triggers scan sequence</td> </tr> <tr> <td>7</td> <td>PRSCH7</td> <td>PRS ch 7 triggers scan sequence</td> </tr> </tbody> </table>					Value	Mode	Description	0	PRSCH0	PRS ch 0 triggers scan sequence	1	PRSCH1	PRS ch 1 triggers scan sequence	2	PRSCH2	PRS ch 2 triggers scan sequence	3	PRSCH3	PRS ch 3 triggers scan sequence	4	PRSCH4	PRS ch 4 triggers scan sequence	5	PRSCH5	PRS ch 5 triggers scan sequence	6	PRSCH6	PRS ch 6 triggers scan sequence	7	PRSCH7	PRS ch 7 triggers scan sequence
Value	Mode	Description																													
0	PRSCH0	PRS ch 0 triggers scan sequence																													
1	PRSCH1	PRS ch 1 triggers scan sequence																													
2	PRSCH2	PRS ch 2 triggers scan sequence																													
3	PRSCH3	PRS ch 3 triggers scan sequence																													
4	PRSCH4	PRS ch 4 triggers scan sequence																													
5	PRSCH5	PRS ch 5 triggers scan sequence																													
6	PRSCH6	PRS ch 6 triggers scan sequence																													
7	PRSCH7	PRS ch 7 triggers scan sequence																													
27:25	Reserved	To ensure compatibility with future devices, always write bits to 0. More information in Section 2.1 (p. 3)																													
24	PRSEN	0	RW	Scan Sequence PRS Trigger Enable Enabled/disable PRS trigger of scan sequence.																											
<table border="1"> <thead> <tr> <th>Value</th> <th>Description</th> </tr> </thead> <tbody> <tr> <td>0</td> <td>Scan sequence is not triggered by PRS input</td> </tr> <tr> <td>1</td> <td>Scan sequence is triggered by PRS input selected by PRSEL</td> </tr> </tbody> </table>					Value	Description	0	Scan sequence is not triggered by PRS input	1	Scan sequence is triggered by PRS input selected by PRSEL																					
Value	Description																														
0	Scan sequence is not triggered by PRS input																														
1	Scan sequence is triggered by PRS input selected by PRSEL																														

23:20	AT	0x0	RW	Scan Sample Acquisition Time Select the acquisition time for scan samples.
-------	----	-----	----	--

Bit	Name	Reset	Access	Description
	Value	Mode		Description
	0	1CYCLE		1 ADC_CLK cycle acquisition time for scan samples
	1	2CYCLES		2 ADC_CLK cycles acquisition time for scan samples
	2	4CYCLES		4 ADC_CLK cycles acquisition time for scan samples
	3	8CYCLES		8 ADC_CLK cycles acquisition time for scan samples
	4	16CYCLES		16 ADC_CLK cycles acquisition time for scan samples
	5	32CYCLES		32 ADC_CLK cycles acquisition time for scan samples
	6	64CYCLES		64 ADC_CLK cycles acquisition time for scan samples
	7	128CYCLES		128 ADC_CLK cycles acquisition time for scan samples
	8	256CYCLES		256 ADC_CLK cycles acquisition time for scan samples

19 *Reserved* *To ensure compatibility with future devices, always write bits to 0. More information in Section 2.1 (p. 3)*

18:16 REF 0x0 RW **Scan Sequence Reference Selection**

Select reference to ADC scan sequence.

Value	Mode	Description
0	1V25	Internal 1.25 V reference
1	2V5	Internal 2.5 V reference
2	VDD	VDD
3	5VDIFF	Internal differential 5 V reference
4	EXTSINGLE	Single ended external reference from pin 6
5	2XEXTDIFF	Differential external reference, 2x(pin 6 - pin 7)
6	2XVDD	Unbuffered 2xVDD

15:8 INPUTMASK 0x00 RW **Scan Sequence Input Mask**

Set one or more bits in this mask to select which inputs are included the scan sequence in either single ended or differential mode.

DIFF = 0		
Mode	Value	Description
CH0	00000001	ADCn_CH0 included in mask
CH1	00000010	ADCn_CH1 included in mask
CH2	00000100	ADCn_CH2 included in mask
CH3	00001000	ADCn_CH3 included in mask
CH4	00010000	ADCn_CH4 included in mask
CH5	00100000	ADCn_CH5 included in mask
CH6	01000000	ADCn_CH6 included in mask
CH7	10000000	ADCn_CH7 included in mask
DIFF = 1		
Mode	Value	Description
CH0CH1	00000001	(Positive input: ADCn_CH0 Negative input: ADCn_CH1) included in mask
CH2CH3	00000010	(Positive input: ADCn_CH2 Negative input: ADCn_CH3) included in mask
CH4CH5	00000100	(Positive input: ADCn_CH4 Negative input: ADCn_CH5) included in mask
CH6CH7	00001000	(Positive input: ADCn_CH6 Negative input: ADCn_CH7) included in mask
	0001xxxx-1111xxxx	Reserved

7:6 *Reserved* *To ensure compatibility with future devices, always write bits to 0. More information in Section 2.1 (p. 3)*

5:4 RES 0x0 RW **Scan Sequence Resolution Select**

Select scan sequence conversion resolution.

Value	Mode	Description
0	12BIT	12-bit resolution
1	8BIT	8-bit resolution
2	6BIT	6-bit resolution
3	OVS	Oversampling enabled. Oversampling rate is set in OVSRSSEL

3 *Reserved* *To ensure compatibility with future devices, always write bits to 0. More information in Section 2.1 (p. 3)*

Bit	Name	Reset	Access	Description									
2	ADJ	0	RW	Scan Sequence Result Adjustment Select scan sequence result adjustment.									
<table border="1"> <thead> <tr> <th>Value</th> <th>Mode</th> <th>Description</th> </tr> </thead> <tbody> <tr> <td>0</td> <td>RIGHT</td> <td>Results are right adjusted</td> </tr> <tr> <td>1</td> <td>LEFT</td> <td>Results are left adjusted</td> </tr> </tbody> </table>					Value	Mode	Description	0	RIGHT	Results are right adjusted	1	LEFT	Results are left adjusted
Value	Mode	Description											
0	RIGHT	Results are right adjusted											
1	LEFT	Results are left adjusted											
1	DIFF	0	RW	Scan Sequence Differential Mode Select single ended or differential input.									
<table border="1"> <thead> <tr> <th>Value</th> <th>Description</th> </tr> </thead> <tbody> <tr> <td>0</td> <td>Single ended input</td> </tr> <tr> <td>1</td> <td>Differential input</td> </tr> </tbody> </table>					Value	Description	0	Single ended input	1	Differential input			
Value	Description												
0	Single ended input												
1	Differential input												
0	REP	0	RW	Scan Sequence Repetitive Mode Enable/disable repetitive scan sequence.									
<table border="1"> <thead> <tr> <th>Value</th> <th>Description</th> </tr> </thead> <tbody> <tr> <td>0</td> <td>Scan conversion mode is deactivated after one sequence</td> </tr> <tr> <td>1</td> <td>Scan conversion mode is converting continuously until SCANSTOP is written</td> </tr> </tbody> </table>					Value	Description	0	Scan conversion mode is deactivated after one sequence	1	Scan conversion mode is converting continuously until SCANSTOP is written			
Value	Description												
0	Scan conversion mode is deactivated after one sequence												
1	Scan conversion mode is converting continuously until SCANSTOP is written												

25.5.6 ADCn_IEN - Interrupt Enable Register

Offset	Bit Position																																					
0x014	31	30	29	28	27	26	25	24	23	22	21	20	19	18	17	16	15	14	13	12	11	10	9	8	7	6	5	4	3	2	1	0						
Reset																							0	0													0	0
Access																							RW	RW													RW	RW
Name																							SCANOF	SINGLEOF													SCAN	SINGLE

Bit	Name	Reset	Access	Description
31:10	<i>Reserved</i>	<i>To ensure compatibility with future devices, always write bits to 0. More information in Section 2.1 (p. 3)</i>		
9	SCANOF	0	RW	Scan Result Overflow Interrupt Enable Enable/disable scan result overflow interrupt.
8	SINGLEOF	0	RW	Single Result Overflow Interrupt Enable Enable/disable single result overflow interrupt.
7:2	<i>Reserved</i>	<i>To ensure compatibility with future devices, always write bits to 0. More information in Section 2.1 (p. 3)</i>		
1	SCAN	0	RW	Scan Conversion Complete Interrupt Enable Enable/disable scan conversion complete interrupt.
0	SINGLE	0	RW	Single Conversion Complete Interrupt Enable Enable/disable single conversion complete interrupt.

25.5.7 ADCn_IF - Interrupt Flag Register

Offset	Bit Position																																							
0x018	31	30	29	28	27	26	25	24	23	22	21	20	19	18	17	16	15	14	13	12	11	10	9	8	7	6	5	4	3	2	1	0								
Reset																							0	0															0	0
Access																							R	R															R	R
Name																							SCANOF	SINGLEOF															SCAN	SINGLE

Bit	Name	Reset	Access	Description
31:10	Reserved	To ensure compatibility with future devices, always write bits to 0. More information in Section 2.1 (p. 3)		
9	SCANOF	0	R	Scan Result Overflow Interrupt Flag Indicates scan result overflow when this bit is set.
8	SINGLEOF	0	R	Single Result Overflow Interrupt Flag Indicates single result overflow when this bit is set.
7:2	Reserved	To ensure compatibility with future devices, always write bits to 0. More information in Section 2.1 (p. 3)		
1	SCAN	0	R	Scan Conversion Complete Interrupt Flag Indicates scan conversion complete when this bit is set.
0	SINGLE	0	R	Single Conversion Complete Interrupt Flag Indicates single conversion complete when this bit is set.

25.5.8 ADCn_IFS - Interrupt Flag Set Register

Offset	Bit Position																																							
0x01C	31	30	29	28	27	26	25	24	23	22	21	20	19	18	17	16	15	14	13	12	11	10	9	8	7	6	5	4	3	2	1	0								
Reset																							0	0															0	0
Access																							W1	W1															W1	W1
Name																							SCANOF	SINGLEOF															SCAN	SINGLE

Bit	Name	Reset	Access	Description
31:10	Reserved	To ensure compatibility with future devices, always write bits to 0. More information in Section 2.1 (p. 3)		
9	SCANOF	0	W1	Scan Result Overflow Interrupt Flag Set Write to 1 to set scan result overflow interrupt flag
8	SINGLEOF	0	W1	Single Result Overflow Interrupt Flag Set Write to 1 to set single result overflow interrupt flag.
7:2	Reserved	To ensure compatibility with future devices, always write bits to 0. More information in Section 2.1 (p. 3)		
1	SCAN	0	W1	Scan Conversion Complete Interrupt Flag Set Write to 1 to set scan conversion complete interrupt flag.
0	SINGLE	0	W1	Single Conversion Complete Interrupt Flag Set Write to 1 to set single conversion complete interrupt flag.

25.5.9 ADCn_IFC - Interrupt Flag Clear Register

Offset	Bit Position																																							
0x020	31	30	29	28	27	26	25	24	23	22	21	20	19	18	17	16	15	14	13	12	11	10	9	8	7	6	5	4	3	2	1	0								
Reset																							0	0															0	0
Access																							W1	W1															W1	W1
Name																							SCANOF	SINGLEOF															SCAN	SINGLE

Bit	Name	Reset	Access	Description
31:10	Reserved	To ensure compatibility with future devices, always write bits to 0. More information in Section 2.1 (p. 3)		
9	SCANOF	0	W1	Scan Result Overflow Interrupt Flag Clear Write to 1 to clear scan result overflow interrupt flag.
8	SINGLEOF	0	W1	Single Result Overflow Interrupt Flag Clear Write to 1 to clear single result overflow interrupt flag.
7:2	Reserved	To ensure compatibility with future devices, always write bits to 0. More information in Section 2.1 (p. 3)		
1	SCAN	0	W1	Scan Conversion Complete Interrupt Flag Clear Write to 1 to clear scan conversion complete interrupt flag.
0	SINGLE	0	W1	Single Conversion Complete Interrupt Flag Clear Write to 1 to clear single conversion complete interrupt flag.

25.5.10 ADCn_SINGLEDATA - Single Conversion Result Data

Offset	Bit Position																															
0x024	31	30	29	28	27	26	25	24	23	22	21	20	19	18	17	16	15	14	13	12	11	10	9	8	7	6	5	4	3	2	1	0
Reset	0x00000000																															
Access	R																															
Name	DATA																															

Bit	Name	Reset	Access	Description
31:0	DATA	0x00000000	R	Single Conversion Result Data The register holds the results from the last single conversion. Reading this field clears the SINGLEDV bit in the ADCn_STATUS register.

25.5.11 ADCn_SCANDATA - Scan Conversion Result Data

Offset	Bit Position																																
0x028	31	30	29	28	27	26	25	24	23	22	21	20	19	18	17	16	15	14	13	12	11	10	9	8	7	6	5	4	3	2	1	0	
Reset																	0x00000000																
Access																	R																
Name																	DATA																

Bit	Name	Reset	Access	Description
31:0	DATA	0x00000000	R	Scan Conversion Result Data The register holds the results from the last scan conversion. Reading this field clears the SCANDV bit in the ADCn_STATUS register.

25.5.12 ADCn_SINGLEDATAP - Single Conversion Result Data Peek Register

Offset	Bit Position																																
0x02C	31	30	29	28	27	26	25	24	23	22	21	20	19	18	17	16	15	14	13	12	11	10	9	8	7	6	5	4	3	2	1	0	
Reset																	0x00000000																
Access																	R																
Name																	DATAP																

Bit	Name	Reset	Access	Description
31:0	DATAP	0x00000000	R	Single Conversion Result Data Peek The register holds the results from the last single conversion. Reading this field will not clear SINGLEDV in ADCn_STATUS or SINGLE DMA request.

25.5.13 ADCn_SCANDATAP - Scan Sequence Result Data Peek Register

Offset	Bit Position																															
0x030	31	30	29	28	27	26	25	24	23	22	21	20	19	18	17	16	15	14	13	12	11	10	9	8	7	6	5	4	3	2	1	0
Reset																0x00000000																
Access																R																
Name																DATAP																

Bit	Name	Reset	Access	Description
31:0	DATAP	0x00000000	R	Scan Conversion Result Data Peek The register holds the results from the last scan conversion. Reading this field will not clear SCANDV in ADCn_STATUS or single DMA request.

25.5.14 ADCn_CAL - Calibration Register

Offset	Bit Position																																
0x034	31	30	29	28	27	26	25	24	23	22	21	20	19	18	17	16	15	14	13	12	11	10	9	8	7	6	5	4	3	2	1	0	
Reset					0x3F								0x00								0x3F										0x00		
Access					RW								RW								RW										RW		
Name					SCANGAIN								SCANOFFSET								SINGLEGAIN										SINGLEOFFSET		

Bit	Name	Reset	Access	Description
31	Reserved	To ensure compatibility with future devices, always write bits to 0. More information in Section 2.1 (p. 3)		
30:24	SCANGAIN	0x3F	RW	Scan Mode Gain Calibration Value This register contains the gain calibration value used with scan conversions. This field is set to the production gain calibration value for the 1V25 internal reference during reset, hence the reset value might differ from device to device. The field is unsigned. Higher values lead to higher ADC results.
23	Reserved	To ensure compatibility with future devices, always write bits to 0. More information in Section 2.1 (p. 3)		
22:16	SCANOFFSET	0x00	RW	Scan Mode Offset Calibration Value This register contains the offset calibration value used with scan conversions. This field is set to the production offset calibration value for the 1V25 internal reference during reset, hence the reset value might differ from device to device. The field is encoded as a signed 2's complement number. Higher values lead to lower ADC results.
15	Reserved	To ensure compatibility with future devices, always write bits to 0. More information in Section 2.1 (p. 3)		
14:8	SINGLEGAIN	0x3F	RW	Single Mode Gain Calibration Value This register contains the gain calibration value used with single conversions. This field is set to the production gain calibration value for the 1V25 internal reference during reset, hence the reset value might differ from device to device. The field is unsigned. Higher values lead to higher ADC results.
7	Reserved	To ensure compatibility with future devices, always write bits to 0. More information in Section 2.1 (p. 3)		
6:0	SINGLEOFFSET	0x00	RW	Single Mode Offset Calibration Value

Bit	Name	Reset	Access	Description
<p>This register contains the offset calibration value used with single conversions. This field is set to the production offset calibration value for the 1V25 internal reference during reset, hence the reset value might differ from device to device. The field is encoded as a signed 2's complement number. Higher values lead to lower ADC results.</p>				

25.5.15 ADCn_BIASPROG - Bias Programming Register

Offset	Bit Position																															
0x03C	31	30	29	28	27	26	25	24	23	22	21	20	19	18	17	16	15	14	13	12	11	10	9	8	7	6	5	4	3	2	1	0
Reset												0x7				1						0x7										
Access												RW				RW						RW										
Name												COMPBIAS				HALFBIAS						BIASPROG										

Bit	Name	Reset	Access	Description
31:12	Reserved	<i>To ensure compatibility with future devices, always write bits to 0. More information in Section 2.1 (p. 3)</i>		
11:8	COMPBIAS	0x7	RW	Comparator Bias Value These bits are used to adjust the bias current to the ADC Comparator.
7	Reserved	<i>To ensure compatibility with future devices, always write bits to 0. More information in Section 2.1 (p. 3)</i>		
6	HALFBIAS	1	RW	Half Bias Current Set this bit to halve the bias current.
5:4	Reserved	<i>To ensure compatibility with future devices, always write bits to 0. More information in Section 2.1 (p. 3)</i>		
3:0	BIASPROG	0x7	RW	Bias Programming Value These bits are used to adjust the bias current.

26 DAC - Digital to Analog Converter

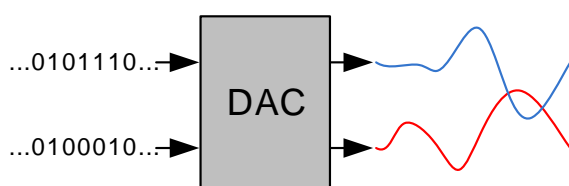
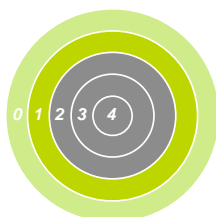

Quick Facts

What?

The DAC is designed for low energy consumption, but can also provide very good performance. It can convert digital values to analog signals at up to 500 kilo samples/second and with 12-bit accuracy.

Why?

The DAC is able to generate accurate analog signals using only a limited amount of energy.

How?

The DAC can generate high-resolution analog signals while the MCU is operating at low frequencies and with low total power consumption. Using DMA and a timer, the DAC can be used to generate waveforms without any CPU intervention.

26.1 Introduction

The Digital to Analog Converter (DAC) can convert a digital value to an analog output voltage. The DAC is fully differential rail-to-rail, with 12-bit resolution. It has two single ended output buffers which can be combined into one differential output. The DAC may be used for a number of different applications such as sensor interfaces or sound output.

26.2 Features

- 500 ksamples/s operation
- Two single ended output channels
 - Can be combined into one differential output
- Integrated prescaler with division factor selectable between 1-128
- Selectable voltage reference
 - Internal 2.5V
 - Internal 1.25V
 - V_{DD}
- Conversion triggers
 - Data write
 - PRS input
- Automatic refresh timer
 - Selection from 16-64 prescaled HFPERCLK cycles
 - Individual refresh enable for each channel
- Interrupt generation on finished conversion
 - Separate interrupt flag for each channel
- PRS output pulse on finished conversion
 - Separate line for each channel
- DMA request on finished conversion
 - Separate request for each channel

- Support for offset and gain calibration
- Output to ADC
- Sine generation mode
- Optional high strength line driver

26.3 Functional Description

An overview of the DAC module is shown in Figure 26.1 (p. 366) .

Figure 26.1. DAC Overview

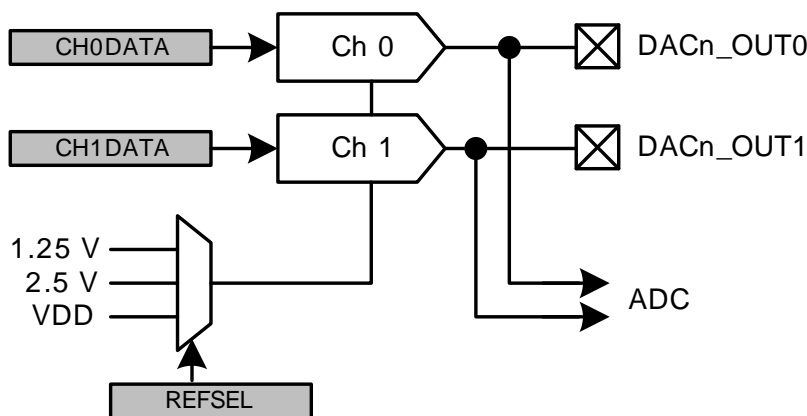

26.3.1 Conversions

The DAC consists of two channels (Channel 0 and 1) with separate 12-bit data registers (DACn_CH0DATA and DACn_CH1DATA). These can be used to produce two independent single ended outputs or the channel 0 register can be used to drive both outputs in differential mode. The DAC supports three conversion modes, continuous, sample/hold, sample/off.

26.3.1.1 Continuous Mode

In continuous mode the DAC channels will drive their outputs continuously with the data in the DACn_CHxDATA registers. This mode will maintain the output voltage and refresh is therefore not needed.

26.3.1.2 Sample/Hold Mode

In sample/hold mode, the DAC cores convert data on a triggered conversion and then hold the output in a sample/hold element. When not converting, the DAC cores are turned off between samples, which reduces the power consumption. Because of output voltage drift the sample/hold element will only hold the output for a certain period without a refresh conversion. The reader is referred to the electrical characteristics for the details on the voltage drift.

26.3.1.3 Sample/Off Mode

In sample/off mode the DAC and the sample/hold element is turned completely off between samples, tristating the DAC output. This requires the DAC output voltage to be held externally. The references are also turned off between samples, which means that a new warm-up period is needed before each conversion.

26.3.1.4 Conversion Start

The DAC channel must be enabled before it can be used. When the channel is enabled, a conversion can be started by writing to the DACn_CHxDATA register. These data registers are also mapped into

a combined data register, DACn_COMBDATA, where the data values for both channels can be written simultaneously. Writing to this register will start all enabled channels.

If the PRSEN bit in DACn_CHxCTRL is set, a DAC conversion on channel x will not be started by data write, but when a positive one HUPERCLK cycle pulse is received on the PRS input selected by PRSSEL in DACn_CHxCTRL.

The CH0DV and CH1DV bits in DACn_STATUS indicate that the corresponding channel contains data that has not yet been converted.

When entering Energy Modes 2,3 or 4, both DAC channels must be stopped. If the DAC is enabled for the first time after entering Energy Mode 2,3 or 4 the output of the DAC will be undefined. This can be worked around by enabling the DAC before entering a lower energy mode. The DAC channel can be enabled and the data registers written to even though the output is disabled.

26.3.1.5 Clock Prescaling

The DAC has an internal clock prescaler, which can divide the HUPERCLK by any factor between 1 and 128, by setting the PRESC bits in DACnCTRL. The resulting DAC_CLK is used by the converter core and the frequency is given by Equation 26.1 (p. 367) :

DAC Clock Prescaling

$$f_{\text{DAC_CLK}} = f_{\text{HUPERCLK}} / 2^{\text{PRESC}} \quad (26.1)$$

where f_{HUPERCLK} is the HUPERCLK frequency. One conversion takes 2 DAC_CLK cycles and the DAC_CLK should not be set higher than 1 MHz.

Normally the PRESCALER runs continuously when either of the channels are enabled. When running with a prescaler setting higher than 0, there will be an unpredictable delay from the time the conversion was triggered to the time the actual conversion takes place. This is because the conversions is controlled by the prescaled clock and the conversion can arrive at any time during a prescaled clock (DAC_CLK) period. However, if the CH0PRESCRST bit in DACn_CTRL is set, the prescaler will be reset every time a conversion is triggered on channel 0. This leads to a predictable latency between channel 0 trigger and conversion.

26.3.2 Reference Selection

Three internal voltage references are available and are selected by setting the REFSEL bits in DACn_CTRL:

- Internal 2.5V
- Internal 1.25V
- V_{DD}

The reference selection can only be changed while both channels are disabled. The references for the DAC need to be enabled for some time before they can be used. This is called the warm-up period, and starts when one of the channels is enabled. For a bandgap reference, this period is 5 DAC_CLK cycles while the V_{DD} reference needs 1 DAC_CLK cycle. The DAC will time this period automatically(given that the prescaler is set correctly) and delay any conversion triggers received during the warm-up until the references have stabilized.

26.3.3 Programming of Bias Current

The bias current of the bandgap reference and the DAC output buffer can be scaled by the BIASPROG and HALFBIAS bit fields of the DACn_BIASPROG register as illustrated in Figure 26.2 (p. 368) .

Figure 26.2. DAC Bias Programming

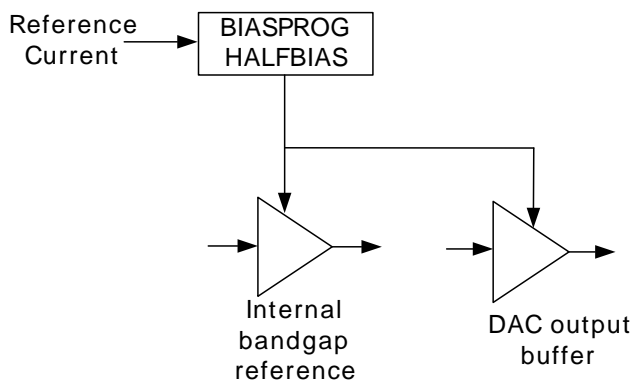

The minimum value of the BIASPROG bitfield of the DACn_BIASPROG register (i.e. BIASPROG=0b0000) represents the minimum bias current. Similarly BIASPROG=0b1111 represents the maximum bias current. The bias current defined by the BIASPROG setting can be halved by setting the HALFBIAS bit of the DACn_BIASPROG register.

The bias current settings should only be changed while both DAC channels are disabled. The electrical characteristics given in the datasheet require the bias configuration to be set to the default values, where no other bias values are given.

26.3.4 Mode

The two DAC channels can act as two separate single ended channels or be combined into one differential channel. This is selected through the DIFF bit in DACn_CTRL.

26.3.4.1 Single Ended Output

When operating in single ended mode, the channel 0 output is on DACn_OUT0 and the channel 1 output is on DACn_OUT1. The output voltage can be calculated using Equation 26.2 (p. 368)

DAC Single Ended Output Voltage

$$V_{OUT} = V_{DACn_OUTx} - V_{SS} = V_{ref} \times CHxDATA/4095 \tag{26.2}$$

where CHxDATA is a 12-bit unsigned integer.

26.3.4.2 Differential Output

When operating in differential mode, both DAC outputs are used as output for the bipolar voltage. The differential conversion uses DACn_CH0DATA as source. The positive output is on DACn_OUT1 and the negative output is on DACn_OUT0. Since the output can be negative, it is expected that the data is written in 2's complement form with the MSB of the 12-bit value being the signed bit. The output voltage can be calculated using Equation 26.3 (p. 368) :

DAC Differential Output Voltage

$$V_{OUT} = V_{DACn_OUT1} - V_{DACn_OUT0} = V_{ref} \times CH0DATA/2047 \tag{26.3}$$

where CH0DATA is a 12-bit signed integer. The common mode voltage is $V_{DD}/2$.

26.3.5 Sine Generation Mode

The DAC contains an automatic sine-generation mode, which is enabled by setting the SINEMODE bit in DACn_CTRL. In this mode, the DAC data is overridden with a conversion data taken from a sine lookup table. The sine signal is controlled by the PRS line selected by CH0PRSEL in DACn_CH0CTRL. When the PRS line is low, a voltage of $V_{ref}/2$ will be produced. When the line is high, a sine wave will be

produced. Each period, starting at 0 degrees, is made up of 16 samples and the frequency is given by Equation 26.4 (p. 369) :

DAC Sine Generation

$$f_{\text{sine}} = f_{\text{HFPERCLK}} / 32 \times (\text{PRESC} + 1) \quad (26.4)$$

The SINE wave will be output on channel 0. If DIFF is set in DACn_CTRL, the sine wave will be output on both channels (if enabled), but inverted (see Figure 26.1 (p. 366)). Note that when OUTENPRS in DACn_CTRL is set, the sine output will be reset to 0 degrees when the PRS line selected by CH1PRSSSEL is low.

Figure 26.3. DAC Sine Mode

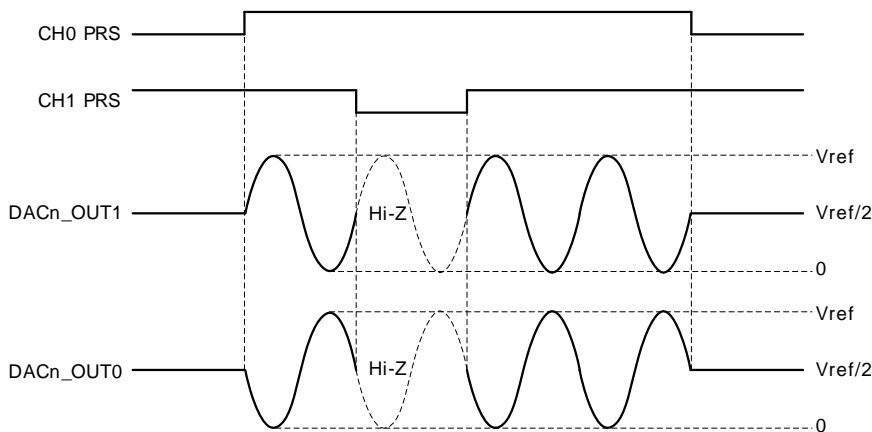

26.3.6 Interrupts and PRS Output

Both DAC channels have separate interrupt flags (in DACn_IF) indicating that a conversion has finished on the channel and that new data can be written to the data registers. Setting one of these flags will result in a DAC interrupt if the corresponding interrupt enable bit is set in DACn_IEN. All generated interrupts from the DAC will activate the same interrupt vector when enabled.

The DAC has two PRS outputs which will carry a one cycle (HFPERCLK) high pulse when the corresponding channel has finished a conversion.

26.3.7 DMA Request

The DAC sends out a DMA request when a conversion on a channel is complete. This request is cleared when the corresponding channel's data register is written.

26.3.8 Analog Output

Each DAC channel has its own output pin (DACn_OUT0 and DACn_OUT1) in addition to an internal loopback to the ADC. These outputs can be enabled and disabled individually in the EN field in DACn_CHxCTRL registers in combination with OUTPUTSEL in DACn_CTRL. The DAC outputs can also be directed to the ADC, which is also configurable in the OUTPUTSEL field in DACn_CTRL.

The DAC outputs are tristated when the channels are not enabled. By setting the OUTENPRS bit in DACn_CTRL, the outputs are also tristated when the PRS line selected by CH1PRSSSEL in DACn_CH1CTRL is low. When the PRS signal is high, the outputs are enabled as normal.

26.3.9 Calibration

The DAC contains a calibration register, DACn_CAL, where calibration values for both offset and gain correction can be written. Offset calibration is done separately for each channel through the CHxOFFSET

bitfields. Gain is calibrated in one common register field, GAIN. The gain calibration is linked to the reference and when the reference is changed, the gain must be re-calibrated. Gain and offset for the 1V25, 2V5 and VDD references are calibrated during production and the calibration values for these can be found in the Device Information page. During reset, the gain and offset calibration registers are loaded with the production calibration values for the 1V25 reference.

26.4 Register Map

The offset register address is relative to the registers base address.

Offset	Name	Type	Description
0x000	DACn_CTRL	RW	Control Register
0x004	DACn_STATUS	R	Status Register
0x008	DACn_CH0CTRL	RW	Channel 0 Control Register
0x00C	DACn_CH1CTRL	RW	Channel 1 Control Register
0x010	DACn_IEN	RW	Interrupt Enable Register
0x014	DACn_IF	R	Interrupt Flag Register
0x018	DACn_IFS	W1	Interrupt Flag Set Register
0x01C	DACn_IFC	W1	Interrupt Flag Clear Register
0x020	DACn_CH0DATA	RW	Channel 0 Data Register
0x024	DACn_CH1DATA	RW	Channel 1 Data Register
0x028	DACn_COMBDATA	W	Combined Data Register
0x02C	DACn_CAL	RW	Calibration Register
0x030	DACn_BIASPROG	RW	Bias Programming Register

26.5 Register Description

26.5.1 DACn_CTRL - Control Register

Offset	Bit Position																																
0x000	31	30	29	28	27	26	25	24	23	22	21	20	19	18	17	16	15	14	13	12	11	10	9	8	7	6	5	4	3	2	1	0	
Reset											0x0			0x0											0x0	0	0	0x1	0x0	0	0		
Access											RW			RW											RW	RW	RW	RW	RW	RW	RW	RW	RW
Name											REFRSEL			PRESC											REFSEL	CHOPRECRST	OUTENPRS	OUTMODE	CONVMODE	SINEMODE	DIFF		

Bit	Name	Reset	Access	Description															
31:22	<i>Reserved</i>	<i>To ensure compatibility with future devices, always write bits to 0. More information in Section 2.1 (p. 3)</i>																	
21:20	REFRSEL	0x0	RW	Refresh Interval Select Select refresh counter timeout value. A channel x will be refreshed with the interval set in this register if the REFREN bit in DACn_CHxCTRL is set. <table border="1"> <thead> <tr> <th>Value</th> <th>Mode</th> <th>Description</th> </tr> </thead> <tbody> <tr> <td>0</td> <td>8CYCLES</td> <td>All channels with enabled refresh are refreshed every 8 prescaled cycles</td> </tr> <tr> <td>1</td> <td>16CYCLES</td> <td>All channels with enabled refresh are refreshed every 16 prescaled cycles</td> </tr> <tr> <td>2</td> <td>32CYCLES</td> <td>All channels with enabled refresh are refreshed every 32 prescaled cycles</td> </tr> <tr> <td>3</td> <td>64CYCLES</td> <td>All channels with enabled refresh are refreshed every 64 prescaled cycles</td> </tr> </tbody> </table>	Value	Mode	Description	0	8CYCLES	All channels with enabled refresh are refreshed every 8 prescaled cycles	1	16CYCLES	All channels with enabled refresh are refreshed every 16 prescaled cycles	2	32CYCLES	All channels with enabled refresh are refreshed every 32 prescaled cycles	3	64CYCLES	All channels with enabled refresh are refreshed every 64 prescaled cycles
Value	Mode	Description																	
0	8CYCLES	All channels with enabled refresh are refreshed every 8 prescaled cycles																	
1	16CYCLES	All channels with enabled refresh are refreshed every 16 prescaled cycles																	
2	32CYCLES	All channels with enabled refresh are refreshed every 32 prescaled cycles																	
3	64CYCLES	All channels with enabled refresh are refreshed every 64 prescaled cycles																	
19	<i>Reserved</i>	<i>To ensure compatibility with future devices, always write bits to 0. More information in Section 2.1 (p. 3)</i>																	
18:16	PRESC	0x0	RW	Prescaler Setting Select clock division factor. <table border="1"> <thead> <tr> <th>Value</th> <th>Description</th> </tr> </thead> <tbody> <tr> <td>PRESC</td> <td>Clock division factor of 2^{PRESC}.</td> </tr> </tbody> </table>	Value	Description	PRESC	Clock division factor of 2 ^{PRESC} .											
Value	Description																		
PRESC	Clock division factor of 2 ^{PRESC} .																		

Bit	Name	Reset	Access	Description
15:10	Reserved	To ensure compatibility with future devices, always write bits to 0. More information in Section 2.1 (p. 3)		
9:8	REFSEL	0x0	RW	Reference Selection
Select reference.				
	Value	Mode	Description	
	0	1V25	Internal 1.25 V bandgap reference	
	1	2V5	Internal 2.5 V bandgap reference	
	2	VDD	VDD reference	
7	CH0PRESCRST	0	RW	Channel 0 Start Reset Prescaler
Select if prescaler is reset on channel 0 start.				
	Value	Description		
	0	Prescaler not reset on channel 0 start		
	1	Prescaler reset on channel 0 start		
6	OUTENPRS	0	RW	PRS Controlled Output Enable
Enable PRS Control of DAC output enable.				
	Value	Description		
	0	DAC output enable always on		
	1	DAC output enable controlled by PRS signal selected for CH1.		
5:4	OUTMODE	0x1	RW	Output Mode
Select output mode.				
	Value	Mode	Description	
	0	DISABLE	DAC output to pin and ADC disabled	
	1	PIN	DAC output to pin enabled. DAC output to ADC disabled	
	2	ADC	DAC output to pin disabled. DAC output to ADC enabled	
	3	PINADC	DAC output to pin and ADC enabled	
3:2	CONVMODE	0x0	RW	Conversion Mode
Configure conversion mode.				
	Value	Mode	Description	
	0	CONTINUOUS	DAC is set in continuous mode	
	1	SAMPLEHOLD	DAC is set in sample/hold mode	
	2	SAMPLEOFF	DAC is set in sample/shut off mode	
1	SINEMODE	0	RW	Sine Mode
Enable/disable sine mode.				
	Value	Description		
	0	Sine mode disabled. Sine reset to 0 degrees		
	1	Sine mode enabled		
0	DIFF	0	RW	Differential Mode
Select single ended or differential mode.				
	Value	Description		
	0	Single ended output		
	1	Differential output		

26.5.2 DACn_STATUS - Status Register

Offset	Bit Position																															
0x004	31	30	29	28	27	26	25	24	23	22	21	20	19	18	17	16	15	14	13	12	11	10	9	8	7	6	5	4	3	2	1	0
Reset																															0	0
Access																															R	R
Name																															CH1DV	CH0DV

Bit	Name	Reset	Access	Description
31:2	Reserved	To ensure compatibility with future devices, always write bits to 0. More information in Section 2.1 (p. 3)		
1	CH1DV	0	R	Channel 1 Data Valid This bit is set high when CH1DATA is written and is set low when CH1DATA is used in conversion.
0	CH0DV	0	R	Channel 0 Data Valid This bit is set high when CH0DATA is written and is set low when CH0DATA is used in conversion.

26.5.3 DACn_CH0CTRL - Channel 0 Control Register

Offset	Bit Position																															
0x008	31	30	29	28	27	26	25	24	23	22	21	20	19	18	17	16	15	14	13	12	11	10	9	8	7	6	5	4	3	2	1	0
Reset																									0x0		0	0	0			
Access																									RW		RW	RW	RW			
Name																									PRSEL		PRSEN	REFREN	EN			

Bit	Name	Reset	Access	Description																											
31:7	Reserved	To ensure compatibility with future devices, always write bits to 0. More information in Section 2.1 (p. 3)																													
6:4	PRSEL	0x0	RW	Channel 0 PRS Trigger Select Select Channel 0 PRS input channel. <table border="1" data-bbox="229 1547 1471 1859"> <thead> <tr> <th>Value</th> <th>Mode</th> <th>Description</th> </tr> </thead> <tbody> <tr><td>0</td><td>PRSCH0</td><td>PRS ch 0 triggers channel 0 conversion.</td></tr> <tr><td>1</td><td>PRSCH1</td><td>PRS ch 1 triggers channel 0 conversion.</td></tr> <tr><td>2</td><td>PRSCH2</td><td>PRS ch 2 triggers channel 0 conversion.</td></tr> <tr><td>3</td><td>PRSCH3</td><td>PRS ch 3 triggers channel 0 conversion.</td></tr> <tr><td>4</td><td>PRSCH4</td><td>PRS ch 4 triggers channel 0 conversion.</td></tr> <tr><td>5</td><td>PRSCH5</td><td>PRS ch 5 triggers channel 0 conversion.</td></tr> <tr><td>6</td><td>PRSCH6</td><td>PRS ch 6 triggers channel 0 conversion.</td></tr> <tr><td>7</td><td>PRSCH7</td><td>PRS ch 7 triggers channel 0 conversion.</td></tr> </tbody> </table>	Value	Mode	Description	0	PRSCH0	PRS ch 0 triggers channel 0 conversion.	1	PRSCH1	PRS ch 1 triggers channel 0 conversion.	2	PRSCH2	PRS ch 2 triggers channel 0 conversion.	3	PRSCH3	PRS ch 3 triggers channel 0 conversion.	4	PRSCH4	PRS ch 4 triggers channel 0 conversion.	5	PRSCH5	PRS ch 5 triggers channel 0 conversion.	6	PRSCH6	PRS ch 6 triggers channel 0 conversion.	7	PRSCH7	PRS ch 7 triggers channel 0 conversion.
Value	Mode	Description																													
0	PRSCH0	PRS ch 0 triggers channel 0 conversion.																													
1	PRSCH1	PRS ch 1 triggers channel 0 conversion.																													
2	PRSCH2	PRS ch 2 triggers channel 0 conversion.																													
3	PRSCH3	PRS ch 3 triggers channel 0 conversion.																													
4	PRSCH4	PRS ch 4 triggers channel 0 conversion.																													
5	PRSCH5	PRS ch 5 triggers channel 0 conversion.																													
6	PRSCH6	PRS ch 6 triggers channel 0 conversion.																													
7	PRSCH7	PRS ch 7 triggers channel 0 conversion.																													
3	Reserved	To ensure compatibility with future devices, always write bits to 0. More information in Section 2.1 (p. 3)																													
2	PRSEN	0	RW	Channel 0 PRS Trigger Enable Select Channel 0 conversion trigger. <table border="1" data-bbox="229 2007 1471 2105"> <thead> <tr> <th>Value</th> <th>Description</th> </tr> </thead> <tbody> <tr><td>0</td><td>Channel 0 is triggered by CH0DATA or COMBDATA write</td></tr> <tr><td>1</td><td>Channel 0 is triggered by PRS input</td></tr> </tbody> </table>	Value	Description	0	Channel 0 is triggered by CH0DATA or COMBDATA write	1	Channel 0 is triggered by PRS input																					
Value	Description																														
0	Channel 0 is triggered by CH0DATA or COMBDATA write																														
1	Channel 0 is triggered by PRS input																														

Bit	Name	Reset	Access	Description						
1	REFREN	0	RW	Channel 0 Automatic Refresh Enable Set to enable automatic refresh of channel 0. Refresh period is set by REFRSEL in DACn_CTRL.						
<table border="1"> <thead> <tr> <th>Value</th> <th>Description</th> </tr> </thead> <tbody> <tr> <td>0</td> <td>Channel 0 is not refreshed automatically</td> </tr> <tr> <td>1</td> <td>Channel 0 is refreshed automatically</td> </tr> </tbody> </table>					Value	Description	0	Channel 0 is not refreshed automatically	1	Channel 0 is refreshed automatically
Value	Description									
0	Channel 0 is not refreshed automatically									
1	Channel 0 is refreshed automatically									
0	EN	0	RW	Channel 0 Enable Enable/disable channel 0.						

26.5.4 DACn_CH1CTRL - Channel 1 Control Register

Offset	Bit Position																															
0x00C	31	30	29	28	27	26	25	24	23	22	21	20	19	18	17	16	15	14	13	12	11	10	9	8	7	6	5	4	3	2	1	0
Reset																									0x0			0	0	0		
Access																									RW			RW	RW	RW		
Name																									PRSEL			PRSEN	REFREN	EN		

Bit	Name	Reset	Access	Description																											
31:7	<i>Reserved</i>	<i>To ensure compatibility with future devices, always write bits to 0. More information in Section 2.1 (p. 3)</i>																													
6:4	PRSEL	0x0	RW	Channel 1 PRS Trigger Select Select Channel 1 PRS input channel.																											
<table border="1"> <thead> <tr> <th>Value</th> <th>Mode</th> <th>Description</th> </tr> </thead> <tbody> <tr> <td>0</td> <td>PRSCH0</td> <td>PRS ch 0 triggers channel 1 conversion.</td> </tr> <tr> <td>1</td> <td>PRSCH1</td> <td>PRS ch 1 triggers channel 1 conversion.</td> </tr> <tr> <td>2</td> <td>PRSCH2</td> <td>PRS ch 2 triggers channel 1 conversion.</td> </tr> <tr> <td>3</td> <td>PRSCH3</td> <td>PRS ch 3 triggers channel 1 conversion.</td> </tr> <tr> <td>4</td> <td>PRSCH4</td> <td>PRS ch 4 triggers channel 1 conversion.</td> </tr> <tr> <td>5</td> <td>PRSCH5</td> <td>PRS ch 5 triggers channel 1 conversion.</td> </tr> <tr> <td>6</td> <td>PRSCH6</td> <td>PRS ch 6 triggers channel 1 conversion.</td> </tr> <tr> <td>7</td> <td>PRSCH7</td> <td>PRS ch 7 triggers channel 1 conversion.</td> </tr> </tbody> </table>					Value	Mode	Description	0	PRSCH0	PRS ch 0 triggers channel 1 conversion.	1	PRSCH1	PRS ch 1 triggers channel 1 conversion.	2	PRSCH2	PRS ch 2 triggers channel 1 conversion.	3	PRSCH3	PRS ch 3 triggers channel 1 conversion.	4	PRSCH4	PRS ch 4 triggers channel 1 conversion.	5	PRSCH5	PRS ch 5 triggers channel 1 conversion.	6	PRSCH6	PRS ch 6 triggers channel 1 conversion.	7	PRSCH7	PRS ch 7 triggers channel 1 conversion.
Value	Mode	Description																													
0	PRSCH0	PRS ch 0 triggers channel 1 conversion.																													
1	PRSCH1	PRS ch 1 triggers channel 1 conversion.																													
2	PRSCH2	PRS ch 2 triggers channel 1 conversion.																													
3	PRSCH3	PRS ch 3 triggers channel 1 conversion.																													
4	PRSCH4	PRS ch 4 triggers channel 1 conversion.																													
5	PRSCH5	PRS ch 5 triggers channel 1 conversion.																													
6	PRSCH6	PRS ch 6 triggers channel 1 conversion.																													
7	PRSCH7	PRS ch 7 triggers channel 1 conversion.																													
3	<i>Reserved</i>	<i>To ensure compatibility with future devices, always write bits to 0. More information in Section 2.1 (p. 3)</i>																													
2	PRSEN	0	RW	Channel 1 PRS Trigger Enable Select Channel 1 conversion trigger.																											
<table border="1"> <thead> <tr> <th>Value</th> <th>Description</th> </tr> </thead> <tbody> <tr> <td>0</td> <td>Channel 1 is triggered by CH1DATA or COMBDATA write</td> </tr> <tr> <td>1</td> <td>Channel 1 is triggered by PRS input</td> </tr> </tbody> </table>					Value	Description	0	Channel 1 is triggered by CH1DATA or COMBDATA write	1	Channel 1 is triggered by PRS input																					
Value	Description																														
0	Channel 1 is triggered by CH1DATA or COMBDATA write																														
1	Channel 1 is triggered by PRS input																														
1	REFREN	0	RW	Channel 1 Automatic Refresh Enable Set to enable automatic refresh of channel 1. Refresh period is set by REFRSEL in DACn_CTRL.																											
<table border="1"> <thead> <tr> <th>Value</th> <th>Description</th> </tr> </thead> <tbody> <tr> <td>0</td> <td>Channel 1 is not refreshed automatically</td> </tr> <tr> <td>1</td> <td>Channel 1 is refreshed automatically</td> </tr> </tbody> </table>					Value	Description	0	Channel 1 is not refreshed automatically	1	Channel 1 is refreshed automatically																					
Value	Description																														
0	Channel 1 is not refreshed automatically																														
1	Channel 1 is refreshed automatically																														
0	EN	0	RW	Channel 1 Enable Enable/disable channel 1.																											

26.5.5 DACn_IEN - Interrupt Enable Register

Offset	Bit Position																															
0x010	31	30	29	28	27	26	25	24	23	22	21	20	19	18	17	16	15	14	13	12	11	10	9	8	7	6	5	4	3	2	1	0
Reset																									0	0			0	0		
Access																									RW	RW			RW	RW		
Name																									CH1UF	CH0UF			CH1	CH0		

Bit	Name	Reset	Access	Description
31:6	<i>Reserved</i>	<i>To ensure compatibility with future devices, always write bits to 0. More information in Section 2.1 (p. 3)</i>		
5	CH1UF	0	RW	Channel 1 Conversion Data Underflow Interrupt Enable Enable/disable channel 1 data underflow interrupt.
4	CH0UF	0	RW	Channel 0 Conversion Data Underflow Interrupt Enable Enable/disable channel 0 data underflow interrupt.
3:2	<i>Reserved</i>	<i>To ensure compatibility with future devices, always write bits to 0. More information in Section 2.1 (p. 3)</i>		
1	CH1	0	RW	Channel 1 Conversion Complete Interrupt Enable Enable/disable channel 1 conversion complete interrupt.
0	CH0	0	RW	Channel 0 Conversion Complete Interrupt Enable Enable/disable channel 0 conversion complete interrupt.

26.5.6 DACn_IF - Interrupt Flag Register

Offset	Bit Position																															
0x014	31	30	29	28	27	26	25	24	23	22	21	20	19	18	17	16	15	14	13	12	11	10	9	8	7	6	5	4	3	2	1	0
Reset																									0	0			0	0		
Access																									R	R			R	R		
Name																									CH1UF	CH0UF			CH1	CH0		

Bit	Name	Reset	Access	Description
31:6	<i>Reserved</i>	<i>To ensure compatibility with future devices, always write bits to 0. More information in Section 2.1 (p. 3)</i>		
5	CH1UF	0	R	Channel 1 Data Underflow Interrupt Flag Indicates channel 1 data underflow.
4	CH0UF	0	R	Channel 0 Data Underflow Interrupt Flag Indicates channel 0 data underflow.
3:2	<i>Reserved</i>	<i>To ensure compatibility with future devices, always write bits to 0. More information in Section 2.1 (p. 3)</i>		
1	CH1	0	R	Channel 1 Conversion Complete Interrupt Flag Indicates channel 1 conversion complete.
0	CH0	0	R	Channel 0 Conversion Complete Interrupt Flag Indicates channel 0 conversion complete.

26.5.7 DACn_IFS - Interrupt Flag Set Register

Offset	Bit Position																															
0x018	31	30	29	28	27	26	25	24	23	22	21	20	19	18	17	16	15	14	13	12	11	10	9	8	7	6	5	4	3	2	1	0
Reset																									0	0			0	0		
Access																									W1	W1			W1	W1		
Name																									CH1UF	CH0UF			CH1	CH0		

Bit	Name	Reset	Access	Description
31:6	Reserved	To ensure compatibility with future devices, always write bits to 0. More information in Section 2.1 (p. 3)		
5	CH1UF	0	W1	Channel 1 Data Underflow Interrupt Flag Set Write to 1 to set channel 1 Data Underflow interrupt flag.
4	CH0UF	0	W1	Channel 0 Data Underflow Interrupt Flag Set Write to 1 to set channel 0 Data Underflow interrupt flag.
3:2	Reserved	To ensure compatibility with future devices, always write bits to 0. More information in Section 2.1 (p. 3)		
1	CH1	0	W1	Channel 1 Conversion Complete Interrupt Flag Set Write to 1 to set channel 1 conversion complete interrupt flag.
0	CH0	0	W1	Channel 0 Conversion Complete Interrupt Flag Set Write to 1 to set channel 0 conversion complete interrupt flag.

26.5.8 DACn_IFC - Interrupt Flag Clear Register

Offset	Bit Position																															
0x01C	31	30	29	28	27	26	25	24	23	22	21	20	19	18	17	16	15	14	13	12	11	10	9	8	7	6	5	4	3	2	1	0
Reset																									0	0			0	0		
Access																									W1	W1			W1	W1		
Name																									CH1UF	CH0UF			CH1	CH0		

Bit	Name	Reset	Access	Description
31:6	Reserved	To ensure compatibility with future devices, always write bits to 0. More information in Section 2.1 (p. 3)		
5	CH1UF	0	W1	Channel 1 Data Underflow Interrupt Flag Clear Write to 1 to clear channel 1 data underflow interrupt flag.
4	CH0UF	0	W1	Channel 0 Data Underflow Interrupt Flag Clear Write to 1 to clear channel 0 data underflow interrupt flag.
3:2	Reserved	To ensure compatibility with future devices, always write bits to 0. More information in Section 2.1 (p. 3)		
1	CH1	0	W1	Channel 1 Conversion Complete Interrupt Flag Clear Write to 1 to clear channel 1 conversion complete interrupt flag.
0	CH0	0	W1	Channel 0 Conversion Complete Interrupt Flag Clear Write to 1 to clear channel 0 conversion complete interrupt flag.

26.5.9 DACn_CH0DATA - Channel 0 Data Register

Offset	Bit Position																															
0x020	31	30	29	28	27	26	25	24	23	22	21	20	19	18	17	16	15	14	13	12	11	10	9	8	7	6	5	4	3	2	1	0
Reset																							0x000									
Access																							RW									
Name																							DATA									

Bit	Name	Reset	Access	Description
31:12	Reserved	To ensure compatibility with future devices, always write bits to 0. More information in Section 2.1 (p. 3)		
11:0	DATA	0x000	RW	Channel 0 Data This register contains the value which will be converted by channel 0.

26.5.10 DACn_CH1DATA - Channel 1 Data Register

Offset	Bit Position																															
0x024	31	30	29	28	27	26	25	24	23	22	21	20	19	18	17	16	15	14	13	12	11	10	9	8	7	6	5	4	3	2	1	0
Reset																							0x000									
Access																							RW									
Name																							DATA									

Bit	Name	Reset	Access	Description
31:12	Reserved	To ensure compatibility with future devices, always write bits to 0. More information in Section 2.1 (p. 3)		
11:0	DATA	0x000	RW	Channel 1 Data This register contains the value which will be converted by channel 1.

26.5.11 DACn_COMBDATA - Combined Data Register

Offset	Bit Position																															
0x028	31	30	29	28	27	26	25	24	23	22	21	20	19	18	17	16	15	14	13	12	11	10	9	8	7	6	5	4	3	2	1	0
Reset												0x000											0x000									
Access												W											W									
Name												CH1DATA											CH0DATA									

Bit	Name	Reset	Access	Description
31:28	Reserved	To ensure compatibility with future devices, always write bits to 0. More information in Section 2.1 (p. 3)		

Bit	Name	Reset	Access	Description
27:16	CH1DATA	0x000	W	Channel 1 Data Data written to this register will be written to DATA in DACn_CH1DATA.
15:12	<i>Reserved</i>	<i>To ensure compatibility with future devices, always write bits to 0. More information in Section 2.1 (p. 3)</i>		
11:0	CH0DATA	0x000	W	Channel 0 Data Data written to this register will be written to DATA in DACn_CH0DATA.

26.5.12 DACn_CAL - Calibration Register

Offset	Bit Position																															
0x02C	31	30	29	28	27	26	25	24	23	22	21	20	19	18	17	16	15	14	13	12	11	10	9	8	7	6	5	4	3	2	1	0
Reset												0x40						0x00						0x00								
Access												RW						RW						RW								
Name												GAIN						CH1OFFSET						CH0OFFSET								

Bit	Name	Reset	Access	Description
31:23	<i>Reserved</i>	<i>To ensure compatibility with future devices, always write bits to 0. More information in Section 2.1 (p. 3)</i>		
22:16	GAIN	0x40	RW	Gain Calibration Value This register contains the gain calibration value. This field is set to the production gain calibration value for the 1V25 internal reference during reset, hence the reset value might differ from device to device. The field is unsigned. Higher values lead to lower DAC results.
15:14	<i>Reserved</i>	<i>To ensure compatibility with future devices, always write bits to 0. More information in Section 2.1 (p. 3)</i>		
13:8	CH1OFFSET	0x00	RW	Channel 1 Offset Calibration Value This register contains the offset calibration value used with channel 1 conversions. This field is set to the production channel 1 offset calibration value for the 1V25 internal reference during reset, hence the reset value might differ from device to device. The field is sign-magnitude encoded. Higher values lead to lower DAC results.
7:6	<i>Reserved</i>	<i>To ensure compatibility with future devices, always write bits to 0. More information in Section 2.1 (p. 3)</i>		
5:0	CH0OFFSET	0x00	RW	Channel 0 Offset Calibration Value This register contains the offset calibration value used with channel 0 conversions. This field is set to the production channel 0 offset calibration value for the 1V25 internal reference during reset, hence the reset value might differ from device to device. The field is sign-magnitude encoded. Higher values lead to lower DAC results.

26.5.13 DACn_BIASPROG - Bias Programming Register

Offset	Bit Position																																					
0x030	31	30	29	28	27	26	25	24	23	22	21	20	19	18	17	16	15	14	13	12	11	10	9	8	7	6	5	4	3	2	1	0						
Reset																										1							0x7					
Access																										RW							RW					
Name																										HALFBIAS							BIASPROG					

Bit	Name	Reset	Access	Description
31:7	<i>Reserved</i>	<i>To ensure compatibility with future devices, always write bits to 0. More information in Section 2.1 (p. 3)</i>		
6	HALFBIAS	1	RW	Half Bias Current

Bit	Name	Reset	Access	Description
				Set this bit to halve the bias current.
5:4	<i>Reserved</i>			<i>To ensure compatibility with future devices, always write bits to 0. More information in Section 2.1 (p. 3)</i>
3:0	BIASPROG	0x7	RW	Bias Programming Value These bits control the bias current level.

27 AES - Advanced Encryption Standard Accelerator

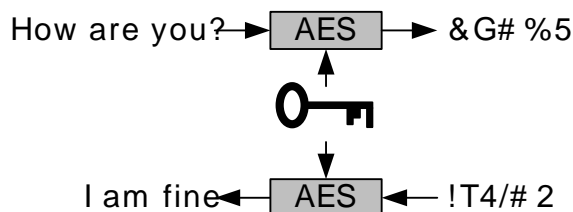
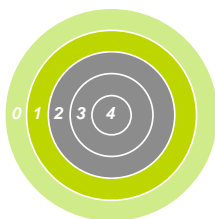

Quick Facts

What?

A fast and energy efficient hardware accelerator for AES-128 and AES-256 encryption and decryption.

Why?

Efficient encryption/decryption with little or no CPU intervention helps to meet the speed and energy demands of the application.

How?

High AES throughput allows the EFM32G to spend more time in lower energy modes. In addition, specialized data access functions allow autonomous DMA/AES operation in both EM0 and EM1.

27.1 Introduction

The Advanced Encryption Standard (FIPS-197) is a symmetric block cipher operating on 128-bit blocks of data and 128-, 192- or 256-bit keys.

The AES accelerator performs AES encryption and decryption with 128-bit or 256-bit keys. Encrypting or decrypting one 128-bit data block takes 54 HFCORECLK cycles with 128-bit keys and 75 HFCORECLK cycles with 256-bit keys. The AES module is an AHB slave which enables efficient access to the data and key registers. All write accesses to the AES module must be 32-bit operations, i.e. 8- or 16-bit operations are not supported.

27.2 Features

- AES hardware encryption/decryption
 - 128-bit key (54 HFCORECLK cycles)
 - 256-bit key (75 HFCORECLK cycles)
- Efficient CPU/DMA support
- Interrupt on finished encryption/decryption
- DMA request on finished encryption/decryption
- Key buffer in AES128 mode
- Optional XOR on Data write

27.3 Functional Description

Some data and a key must be loaded into the KEY and DATA registers before an encryption or decryption can take place. The input data before encryption is called the PlainText and output from the encryption is called CipherText. For encryption, the key is called PlainKey. After one encryption, the resulting key in the KEY registers is the CipherKey. This key must be loaded into the KEY registers before every decryption. After one decryption, the resulting key will be the PlainKey. The resulting PlainKey/CipherKey is only dependent on the value in the KEY registers before encryption/decryption. The resulting keys and data are shown in Figure 27.1 (p. 381) .

Figure 27.1. AES Key and Data Definitions

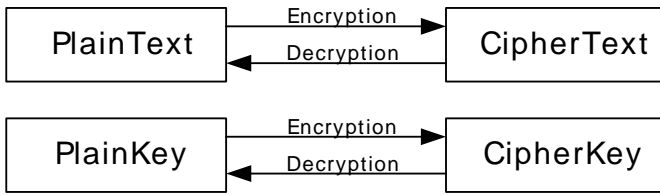

27.3.1 Encryption/Decryption

The AES module can be set to encrypt or decrypt by clearing/setting the DECRYPT bit in AES_CTRL. The AES256 bit in AES_CTRL configures the size of the key used for encryption/decryption. The AES_CTRL register should not be altered while AES is running, as this may lead to unpredictable behaviour.

An AES encryption/decryption can be started in the following ways:

- Writing a 1 to the START bit in AES_CMD
- Writing 4 times 32 bits to AES_DATA when the DATASTART control bit is set
- Writing 4 times 32 bits to AES_XORDATA when the XORSTART control bit is set

An AES encryption/decryption can be stopped by writing a 1 to the STOP bit in AES_CMD. The RUNNING bit in AES_STATUS indicates that an AES encryption/decryption is ongoing.

27.3.2 Data and Key Access

The AES module contains a 128-bit DATA (State) register and two 128-bit KEY registers defined as DATA3-DATA0, KEY3-KEY0 (KEYL) and KEY7-KEY4 (KEYH). In AES128 mode, the 128-bit key is read from KEYL, while both KEYH and KEYL is used in AES256 mode. See Figure 27.2 (p. 381) . The figure presents the key byte order for 256-bit keys. In 128-bit mode a₁₆ represents the first byte of the 128-bit key.

It is important to note the order of the individual bytes in the key and state in relation to how they are defined in the Advanced Encryption Standard (FIPS-197).

Figure 27.2. AES Data and Key Orientation as Defined in the Advanced Encryption Standard

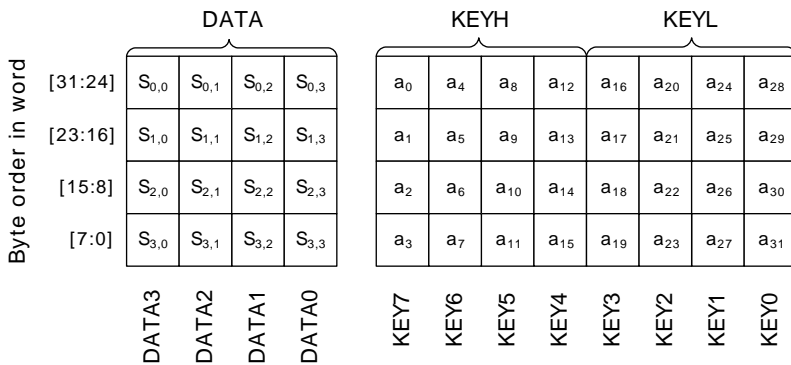

The registers DATA3-DATA0, are not memory mapped directly, but can be written/read by accessing AES_DATA or AES_XORDATA. The same applies for the key registers, KEY3-KEY0 which are accessed through AES_KEYLn (n=A, B, C or D), while KEY7-KEY4 are accessed through KEYHn (n=A, B, C or D). Writing DATA3-DATA0 is then done through 4 consecutive writes to AES_DATA (or AES_XORDATA), starting with the word which is to be written to DATA0. For each write, the words will

be word wise barrel shifted towards the least significant word. Accessing the KEY registers are done in the same fashion through KEYLn and KEYHn. See Figure 27.3 (p. 382). Note that KEYHA, KEYHB, KEYHC and KEYHD are really the same register, just mapped to four different addresses. You can then chose freely which of these addresses you want to use to update the KEY7-KEY4 registers. The same principle applies to the KEYLn registers. Mapping the same registers to multiple addresses like this, allows the DMA controller to write a full 256-bit key in one sweep, when incrementing the address between each word write.

Figure 27.3. AES Data and Key Register Operation

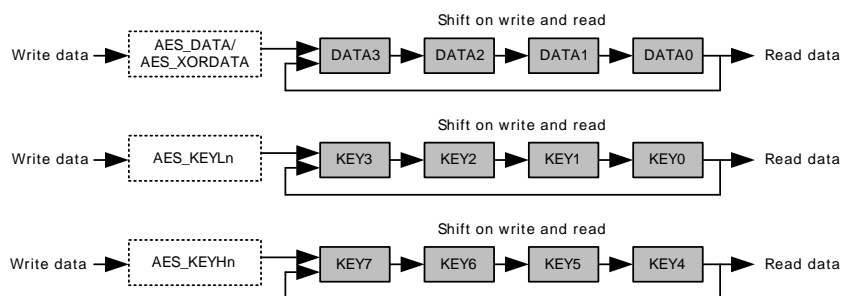

27.3.2.1 Key Buffer

When encrypting multiple blocks of data in a row, the PlainKey must be written to the key register between each encryption, since the contents of the key registers will be turned into the CipherKey during the encryption. The opposite applies when decrypting, where you have to re-supply the CipherKey between each block. However, in AES128 mode, KEY4-KEY7 can be used as a buffer register, to hold an extra copy of the KEY4-KEY0 registers. When KEYBUFEN is set in AES_CTRL, the contents of KEY7-KEY4 are copied to KEY4-KEY0, when an encryption/decryption is started. This eliminates the need for re-loading the KEY for every encrypted/decrypted block when running in AES128 mode.

27.3.2.2 Data Write XOR

The AES module contains an array of XOR gates connected to the DATA registers, which can be used during a data write to XOR the existing contents of the registers with the new data written. To use the XOR function, the data must be written to AES_XORDATA location.

Reading data from AES_XORDATA is equivalent to reading data from AES_DATA.

27.3.2.3 Start on Data Write

The AES module can be configured to start an encryption/decryption when the new data has been written to AES_DATA and/or AES_XORDATA. A 2-bit counter is incremented each time the AES_DATA or AES_XORDATA registers are written. This counter indicates which data word is written. If DATASTART/XORSTART in AES_CTRL is set, an encryption will start each time the counter overflows (DATA3 is written). Writing to the AES_CTRL register will reset the counter to 0.

27.3.3 Interrupt Request

The DONE interrupt flag is set when an encryption/ decryption has finished.

27.3.4 DMA Request

The AES module has 4 DMA requests which are all set on a finished encryption/decryption and cleared on the following conditions:

- DATAWR: Cleared on a AES_DATA write or AES_CTRL write
- XORDATAWR: Cleared on a AES_XORDATA write or AES_CTRL write
- DATARD: Cleared on a AES_DATA read or AES_CTRL write

- KEYWR: Cleared on a AES_KEYHn write or AES_CTRL write

27.3.5 Block Chaining Example

Example 27.1 (p. 383) below illustrates how the AES module could be configured to perform Cipher Block Chaining with 128-bit keys.

Example 27.1. AES Cipher Block Chaining

1. Configure module to encryption, key buffer enabled and XORSTART in AES_CTRL
2. Write 128-bit initialization vector to AES_DATA, starting with least significant word.
3. Write PlainKey to AES_KEYHn, starting with least significant word.
4. Write PlainText to AES_XORDATA, starting with least significant word. Encryption will be started when the DATA3 is written. KEYH (PlainKey) will be copied to KEYL before encryption starts.
5. When encryption finished, read CipherText from AES_DATA, starting with least significant word.
6. Loop to step 4, if new PlainText is available.

27.4 Register Map

The offset register address is relative to the registers base address.

Offset	Name	Type	Description
0x000	AES_CTRL	RW	Control Register
0x004	AES_CMD	W1	Command Register
0x008	AES_STATUS	R	Status Register
0x00C	AES_IEN	RW	Interrupt Enable Register
0x010	AES_IF	R	Interrupt Flag Register
0x014	AES_IFS	W1	Interrupt Flag Set Register
0x018	AES_IFC	W1	Interrupt Flag Clear Register
0x01C	AES_DATA	RW	DATA Register
0x020	AES_XORDATA	RW	XORDATA Register
0x030	AES_KEYLA	RW	KEY Low Register
0x034	AES_KEYLB	RW	KEY Low Register
0x038	AES_KEYLC	RW	KEY Low Register
0x03C	AES_KEYLD	RW	KEY Low Register
0x040	AES_KEYHA	RW	KEY High Register
0x044	AES_KEYHB	RW	KEY High Register
0x048	AES_KEYHC	RW	KEY High Register
0x04C	AES_KEYHD	RW	KEY High Register

27.5 Register Description

27.5.1 AES_CTRL - Control Register

Offset	Bit Position																																																								
	31	30	29	28	27	26	25	24	23	22	21	20	19	18	17	16	15	14	13	12	11	10	9	8	7	6	5	4	3	2	1	0																									
0x000																																																									
Reset																												0	0																												
Access																												RW	RW																												
Name																												XORSTART	DATASTART																												

Bit	Name	Reset	Access	Description
31:6	Reserved	To ensure compatibility with future devices, always write bits to 0. More information in Section 2.1 (p. 3)		
5	XORSTART	0	RW	AES_XORDATA Write Start Set this bit to start encryption/decryption when DATA3 is written through AES_XORDATA.
4	DATASTART	0	RW	AES_DATA Write Start Set this bit to start encryption/decryption when DATA3 is written through AES_DATA.
3	Reserved	To ensure compatibility with future devices, always write bits to 0. More information in Section 2.1 (p. 3)		
2	KEYBUFEN	0	RW	Key Buffer Enable Enable/disable key buffer in AES-128 mode.
1	AES256	0	RW	AES-256 Mode Select AES-128 or AES-256 mode.

Bit	Name	Reset	Access	Description
	Value	Description		
	0	AES-128 mode		
	1	AES-256 mode		
0	DECRYPT	0	RW	Decryption/Encryption Mode Select encryption or decryption.
	Value	Description		
	0	AES Encryption		
	1	AES Decryption		

27.5.2 AES_CMD - Command Register

Offset	Bit Position																															
0x004	31	30	29	28	27	26	25	24	23	22	21	20	19	18	17	16	15	14	13	12	11	10	9	8	7	6	5	4	3	2	1	0
Reset																															0	0
Access																															W1	W1
Name																															STOP	START

Bit	Name	Reset	Access	Description
31:2	<i>Reserved</i>	<i>To ensure compatibility with future devices, always write bits to 0. More information in Section 2.1 (p. 3)</i>		
1	STOP	0	W1	Encryption/Decryption Stop Set to stop encryption/decryption.
0	START	0	W1	Encryption/Decryption Start Set to start encryption/decryption.

27.5.3 AES_STATUS - Status Register

Offset	Bit Position																															
0x008	31	30	29	28	27	26	25	24	23	22	21	20	19	18	17	16	15	14	13	12	11	10	9	8	7	6	5	4	3	2	1	0
Reset																																0
Access																																R
Name																																RUNNING

Bit	Name	Reset	Access	Description
31:1	<i>Reserved</i>	<i>To ensure compatibility with future devices, always write bits to 0. More information in Section 2.1 (p. 3)</i>		
0	RUNNING	0	R	AES Running This bit indicates that the AES module is running an encryption/decryption.

27.5.4 AES_IEN - Interrupt Enable Register

Offset	Bit Position																															
0x00C	31	30	29	28	27	26	25	24	23	22	21	20	19	18	17	16	15	14	13	12	11	10	9	8	7	6	5	4	3	2	1	0
Reset																																0
Access																																RW
Name																																DONE

Bit	Name	Reset	Access	Description
31:1	Reserved	To ensure compatibility with future devices, always write bits to 0. More information in Section 2.1 (p. 3)		
0	DONE	0	RW	Encryption/Decryption Done Interrupt Enable Enable/disable interrupt on encryption/decryption done.

27.5.5 AES_IF - Interrupt Flag Register

Offset	Bit Position																															
0x010	31	30	29	28	27	26	25	24	23	22	21	20	19	18	17	16	15	14	13	12	11	10	9	8	7	6	5	4	3	2	1	0
Reset																																0
Access																																R
Name																																DONE

Bit	Name	Reset	Access	Description
31:1	Reserved	To ensure compatibility with future devices, always write bits to 0. More information in Section 2.1 (p. 3)		
0	DONE	0	R	Encryption/Decryption Done Interrupt Flag Set when an encryption/decryption has finished.

27.5.6 AES_IFS - Interrupt Flag Set Register

Offset	Bit Position																															
0x014	31	30	29	28	27	26	25	24	23	22	21	20	19	18	17	16	15	14	13	12	11	10	9	8	7	6	5	4	3	2	1	0
Reset																																0
Access																																W1
Name																																DONE

Bit	Name	Reset	Access	Description
31:1	Reserved	To ensure compatibility with future devices, always write bits to 0. More information in Section 2.1 (p. 3)		
0	DONE	0	W1	Encryption/Decryption Done Interrupt Flag Set Write to 1 to set encryption/decryption done interrupt flag

27.5.7 AES_IFC - Interrupt Flag Clear Register

Offset	Bit Position																															
0x018	31	30	29	28	27	26	25	24	23	22	21	20	19	18	17	16	15	14	13	12	11	10	9	8	7	6	5	4	3	2	1	0
Reset																																0
Access																																W1
Name																																DONE

Bit	Name	Reset	Access	Description
31:1	Reserved	To ensure compatibility with future devices, always write bits to 0. More information in Section 2.1 (p. 3)		
0	DONE	0	W1	Encryption/Decryption Done Interrupt Flag Clear Write to 1 to clear encryption/decryption done interrupt flag

27.5.8 AES_DATA - DATA Register

Offset	Bit Position																															
0x01C	31	30	29	28	27	26	25	24	23	22	21	20	19	18	17	16	15	14	13	12	11	10	9	8	7	6	5	4	3	2	1	0
Reset																																0x00000000
Access																																RW
Name																																DATA

Bit	Name	Reset	Access	Description
31:0	DATA	0x00000000	RW	Data Access Access data through this register.

27.5.9 AES_XORDATA - XORDATA Register

Offset	Bit Position																															
0x020	31	30	29	28	27	26	25	24	23	22	21	20	19	18	17	16	15	14	13	12	11	10	9	8	7	6	5	4	3	2	1	0
Reset																																0x00000000
Access																																RW
Name																																XORDATA

Bit	Name	Reset	Access	Description
31:0	XORDATA	0x00000000	RW	XOR Data Access Access data with XOR function through this register.

27.5.10 AES_KEYLA - KEY Low Register

Offset	Bit Position																																
0x030	31	30	29	28	27	26	25	24	23	22	21	20	19	18	17	16	15	14	13	12	11	10	9	8	7	6	5	4	3	2	1	0	
Reset																	0x00000000																
Access																	RW																
Name																	KEYLA																

Bit	Name	Reset	Access	Description
31:0	KEYLA	0x00000000	RW	Key Low Access A Access the low key words through this register.

27.5.11 AES_KEYLB - KEY Low Register

Offset	Bit Position																																
0x034	31	30	29	28	27	26	25	24	23	22	21	20	19	18	17	16	15	14	13	12	11	10	9	8	7	6	5	4	3	2	1	0	
Reset																	0x00000000																
Access																	RW																
Name																	KEYLB																

Bit	Name	Reset	Access	Description
31:0	KEYLB	0x00000000	RW	Key Low Access B Access the low key words through this register.

27.5.12 AES_KEYLC - KEY Low Register

Offset	Bit Position																																
0x038	31	30	29	28	27	26	25	24	23	22	21	20	19	18	17	16	15	14	13	12	11	10	9	8	7	6	5	4	3	2	1	0	
Reset																	0x00000000																
Access																	RW																
Name																	KEYLC																

Bit	Name	Reset	Access	Description
31:0	KEYLC	0x00000000	RW	Key Low Access C Access the low key words through this register.

27.5.13 AES_KEYLD - KEY Low Register

Offset	Bit Position																																
0x03C	31	30	29	28	27	26	25	24	23	22	21	20	19	18	17	16	15	14	13	12	11	10	9	8	7	6	5	4	3	2	1	0	
Reset																	0x00000000																
Access																	RW																
Name																	KEYLD																

Bit	Name	Reset	Access	Description
31:0	KEYLD	0x00000000	RW	Key Low Access D Access the low key words through this register.

27.5.14 AES_KEYHA - KEY High Register

Offset	Bit Position																																
0x040	31	30	29	28	27	26	25	24	23	22	21	20	19	18	17	16	15	14	13	12	11	10	9	8	7	6	5	4	3	2	1	0	
Reset																	0x00000000																
Access																	RW																
Name																	KEYHA																

Bit	Name	Reset	Access	Description
31:0	KEYHA	0x00000000	RW	Key High Access A Access the high key words through this register.

27.5.15 AES_KEYHB - KEY High Register

Offset	Bit Position																																
0x044	31	30	29	28	27	26	25	24	23	22	21	20	19	18	17	16	15	14	13	12	11	10	9	8	7	6	5	4	3	2	1	0	
Reset																	0x00000000																
Access																	RW																
Name																	KEYHB																

Bit	Name	Reset	Access	Description
31:0	KEYHB	0x00000000	RW	Key High Access B Access the high key words through this register.

27.5.16 AES_KEYHC - KEY High Register

Offset	Bit Position																																
0x048	31	30	29	28	27	26	25	24	23	22	21	20	19	18	17	16	15	14	13	12	11	10	9	8	7	6	5	4	3	2	1	0	
Reset																	0x00000000																
Access																	RW																
Name																	KEYHC																

Bit	Name	Reset	Access	Description
31:0	KEYHC	0x00000000	RW	Key High Access C Access the high key words through this register.

27.5.17 AES_KEYHD - KEY High Register

Offset	Bit Position																																
	31	30	29	28	27	26	25	24	23	22	21	20	19	18	17	16	15	14	13	12	11	10	9	8	7	6	5	4	3	2	1	0	
0x04C																																	
Reset																	0x00000000																
Access																	RW																
Name																	KEYHD																

Bit	Name	Reset	Access	Description
31:0	KEYHD	0x00000000	RW	Key High Access D Access the high key words through this register.

28 GPIO - General Purpose Input/Output

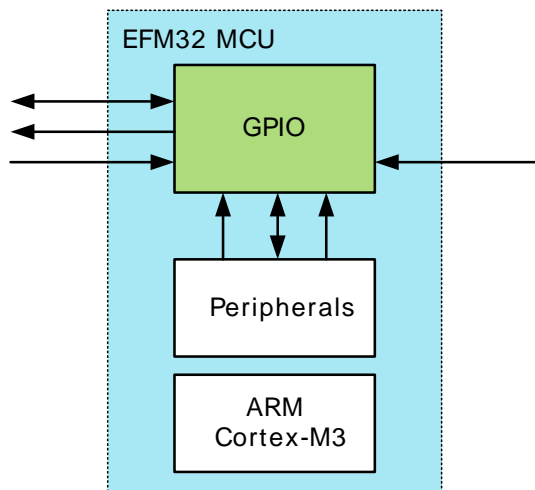
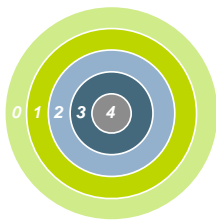

Quick Facts

What?

The GPIO (General Purpose Input/Output) is used for pin configuration and direct pin manipulation and sensing as well as routing for peripheral pin connections.

Why?

Easy to use and highly configurable input/output pins are important to fit many communication protocols as well as minimizing software control overhead. Flexible routing of peripheral functions helps to ease PCB layout.

How?

Each pin on the device can be individually configured as either an input or an output with several different drive modes. Also, individual bit manipulation registers minimizes control overhead. Peripheral connections to pins can be routed to up to 4 different locations, thus solving congestion issues that may arise with multiple functions on the same pin. Fully asynchronous interrupts can also be generated from any pin.

28.1 Introduction

In the EFM32G devices the General Purpose Input/Output (GPIO) pins are organized into ports with up to 16 pins each. These pins can individually be configured as either an output or input. More advanced configurations like open-drain, filtering and drive strength can also be configured individually for the pins. The GPIO pins can also be overridden by peripheral pin connections, like Timer PWM outputs or USART communication, which can be routed to several locations on the device. The GPIO supports up to 16 asynchronous external pin interrupts, which enables interrupts from any pin on the device. Also, the input value of a pin can be routed through the Peripheral Reflex System to other peripherals.

28.2 Features

- Individual configuration for each pin
 - Tristate (reset state)
 - Push-pull
 - Open-drain
 - Pull-up resistor
 - Pull-down resistor
 - Drive strength
 - 0.5 mA
 - 2 mA
 - 6 mA
 - 20 mA

- Glitch suppression input filter.
- Analog connection to e.g. ADC or LCD.
- Alternate functions (e.g. peripheral outputs and inputs)
 - Routed to several locations on the device
 - Pin connections can be enabled individually
 - Output data can be overridden by peripheral
 - Output enable can be overridden by peripheral
- Toggle, set and clear registers for output data
- Dedicated data input register (read-only)
- Interrupts
 - 2 interrupt lines from up to 16 pending sources
 - All GPIO pins are selectable
 - Separate enable, status, set and clear registers
 - Asynchronous sensing
 - Rising, falling or both edges
 - Wake up from EM0-EM3
- Peripheral Reflex System producer
 - All GPIO pins are selectable
- Configuration lock functionality to avoid accidental changes

28.3 Functional Description

An overview of the GPIO module is shown in Figure 28.1 (p. 394). The GPIO pins are grouped into 16-pin ports. Each individual GPIO pin is called P_{xn} where x indicates the port (A, B, C ...) and n indicates the pin number (0,1,...,15). Fewer than 16 bits may be available on some ports, depending on the total number of I/O pins on the package. After a reset both input and output is disabled for all pins on the device, except for debug pins. To use a pin, the port GPIO_P_x_MODEL/GPIO_P_x_MODEH registers must be configured for the pin to make it an input or output. These registers can also do more advanced configuration, which is covered in Section 28.3.1 (p. 394). When the port is either configured as an input or an output, the Data In Register (GPIO_P_x_DIN) can be used to read the level of each pin in the port (bit n in the register is connected to pin n on the port). When configured as an output, the value of the Data Out Register (GPIO_P_x_DOUT) will be driven to the pin.

The DOUT value can be changed in 4 different ways

- Writing to the GPIO_P_x_DOUT register.
- Writing a 1 to a bit in the GPIO_P_x_DOUTSET register sets the corresponding DOUT bit
- Writing a 1 to a bit in the GPIO_P_x_DOUTCLR register clears the corresponding DOUT bit
- Writing a 1 to a bit in the GPIO_P_x_DOUTTGL register toggles the corresponding DOUT bit

Reading the GPIO_P_x_DOUT register will return its contents. Reading the GPIO_P_x_DOUTSET, GPIO_P_x_CLR or GPIO_P_x_TGL will return 0.

Figure 28.1. Pin Configuration

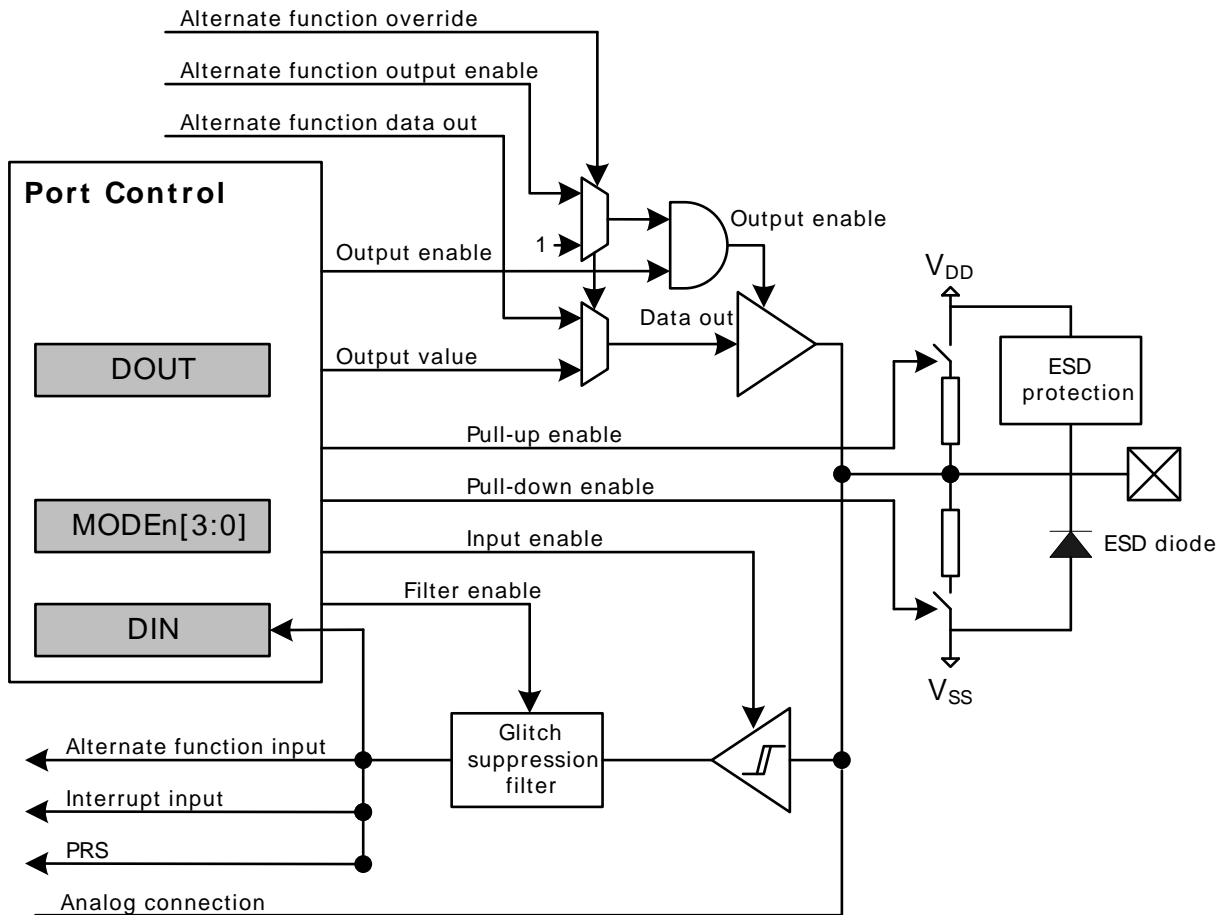

Note There is no ESD diode to Vdd because if using LCD voltage boost the pin voltage will be higher than Vdd. Nevertheless there is an ESD protection block against over voltage.

28.3.1 Pin Configuration

In addition to setting the pins as either outputs or inputs, the GPIO_Px_MODEL and GPIO_Px_MODEH registers can be used for more advanced configurations. GPIO_Px_MODEL contains 8 bit fields named MODEn (n=0,1,..7) which control pins 0-7, while GPIO_Px_MODEH contains 8 bit fields named MODEn (n=8,9,..15) which control pins 8-15. In some modes GPIO_Px_DOUT is also used for extra configurations like pull-up/down and glitch suppression filter enable. Table 28.1 (p. 394) shows the available configurations.

Table 28.1. Pin Configuration

MODEx	Input	Output	DOUT	Pull-down	Pull-up	Alt. strength	Input Filter	Description
0b0000	Disabled	Disabled	0					Input disabled
			1		On			Input disabled with pull-up
0b0001	Enabled		0					Input enabled
			1				On	Input enabled with filter
0b0010			0	On				Input enabled with pull-down
			1		On			Input enabled with pull-up

MODEx	Input	Output	DOUT	Pull-down	Pull-up	Alt. strength	Input Filter	Description
0b0011			0	On			On	Input enabled with pull-down and filter
			1		On		On	Input enabled with pull-up and filter
0b0100		Push-pull	x					Push-pull
0b0101			x			On		Push-pull with alt. drive strength
0b0110		Open Source (Wired-OR)	x					Open-source
0b0111			x	On				Open-source with pull-down
0b1000		Open Drain (Wired-AND)	x					Open-drain
0b1001			x				On	Open-drain with filter
0b1010			x		On			Open-drain with pull-up
0b1011			x		On		On	Open-drain with pull-up and filter
0b1100			x			On		Open-drain with alt. drive strength
0b1101			x			On	On	Open-drain with alt. drive strength and filter
0b1110			x		On	On		Open-drain with alt. drive strength and pull-up
0b1111			x		On	On	On	Open-drain with alt. drive strength, pull-up and filter

MODEn determines which mode the pin is in at a given time. Setting MODEn to 0b0000 disables the pin, reducing power consumption to a minimum. When the output driver is disabled, the pin can be used as a connection for an analog module (e.g. ADC, LCD...). Input is enabled by setting MODEn to any value other than 0b0000. The pull-up, pull-down and filter function can optionally be applied to the input, see Figure 28.2 (p. 395).

The internal pull-up resistance, R_{PU} , and pull-down resistance, R_{PD} , are defined in the device datasheet. When the filter is enabled it suppresses glitches with pulse widths as defined by the parameter $t_{IOGLITCH}$ in the device datasheet.

Figure 28.2. Tristated Output with Optional Pull-up or Pull-down

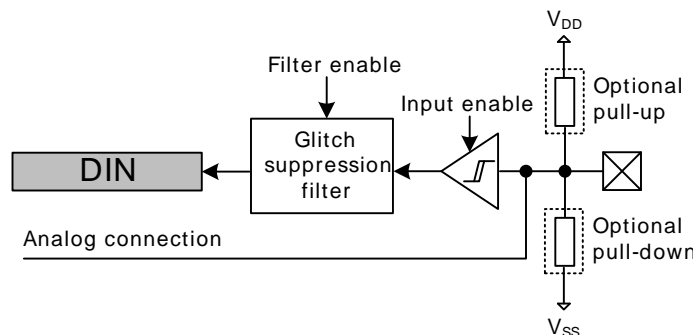

When MODEn=0b0100 or MODEn=0b0101, the pin operates in push-pull mode. In this mode, the pin is driven either high or low, dependent on the value of GPIO_Px_DOUT. The push-pull configuration is shown in Figure 28.3 (p. 396).

Figure 28.3. Push-Pull Configuration

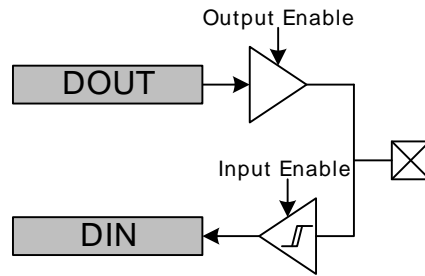

When MODE_n is 0110 or 0111, the pin operates in open-source mode, the latter with a pull-down resistor. When driving a high value in open-source mode, the pull-down is disconnected to save power.

For the remaining MODE_n values, i.e. MODE_n >= 1000, the pin operates in open-drain mode as shown in Figure 28.4 (p. 396). In open-drain mode, the pin can have an input filter, a pull-up, different driver strengths or any combination of these. When driving a low value in open-drain mode, the pull-up is disconnected to save power.

Figure 28.4. Open-drain

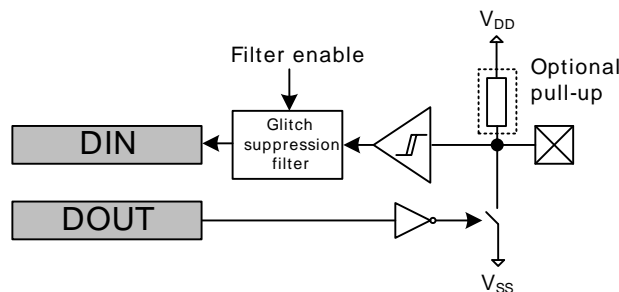

When MODE_n=0b0101 or 0b11xx, the output driver uses the drive strength specified in DRIVEMODE in GPIO_Px_CTRL. In all other output modes, the drive strength is set to 6 mA.

28.3.1.1 Configuration Lock

GPIO_Px_MODEL, GPIO_Px_MODEH, GPIO_Px_CTRL, GPIO_Px_PINLOCKN, GPIO_EXTIPSELL, GPIO_EXTIPSELH, GPIO_INSENSE and GPIO_ROUTE can be locked by writing any other value than 0xA534 to GPIO_LOCK. Writing the value 0xA534 to the GPIOx_LOCK register unlocks the configuration registers.

In addition to configuration lock, GPIO_Px_MODEL, GPIO_Px_MODEH, GPIO_Px_DOUT, GPIO_Px_DOUTSET, GPIO_Px_DOUTCLR, and GPIO_Px_DOUTTGL can be locked individually for each pin by clearing the corresponding bit in GPIO_Px_PINLOCKN. Bits in the GPIO_Px_PINLOCKN register can only be cleared, they are set high again after reset.

28.3.2 Alternate Functions

Alternate functions are connections to pins from Timers, USARTs etc. These modules contain route registers, where the pin connections are enabled. In addition, these registers contain a location bit field, which configures which pins the outputs of that module will be connected to if they are enabled. If an alternate signal output is enabled for a pin and output is enabled for the pin, the alternate function's output data and output enable signals override the data output and output enable signals from the GPIO. However, the pin configuration stays as set in GPIO_Px_MODEL, GPIO_Px_MODEH and GPIO_Px_DOUT registers. I.e. the pin configuration must be set to output enable in GPIO for a peripheral to be able to use the pin as an output.

It is possible, but not recommended to select two or more peripherals as output on the same pin. These signals will then be OR'ed together. However, DTI outputs, which are routed as alternate functions, have

priority, and will never be OR'ed with other alternate functions. The reader is referred to the pin map section of the device datasheet for more information on the possible locations of each alternate function and any priority settings.

28.3.2.1 Serial Wire Debug Port Connection

The SW Debug Port is routed as an alternate function and the SWDIO and SWCLK pin connections are enabled by default with internal pull down resistors. It is possible to disable these pin connections (and disable the pull down resistors) by setting the SWDIOPEN and SWCLKPEN bits in GPIO_ROUTE to 0.

WARNING: When the debug pins are disabled, the device can no longer be accessed by a debugger. A reset will set the debug pins back to their default state as enabled. If you do disable the debug pins, make sure you have at least a 3 second timeout at the start of your program code before you disable the debug pins. This way the debugger will have time to halt the device after a reset before the pins are disabled.

The Serial Wire Viewer Output pin (SWO) can be enabled by setting the SWOPEN bit in GPIO_ROUTE. This bit can also be routed to alternate locations by configuring the LOCATION bitfield in GPIO_ROUTE.

28.3.2.2 Analog Connections

When using the GPIO pin for analog functionality, it is recommended to disable the digital output and set the MODEn in GPIO_Px_MODEL/GPIO_Px_MODEH equal to 0b0000 to disable the input sense and pull resistors.

28.3.3 Interrupt Generation

The GPIO can generate an interrupt from the input of any GPIO pin on a device. The interrupts have asynchronous sense capability, enabling wake-up from energy modes as low as EM3, see Figure 28.5 (p. 397) .

Figure 28.5. Pin n Interrupt Generation

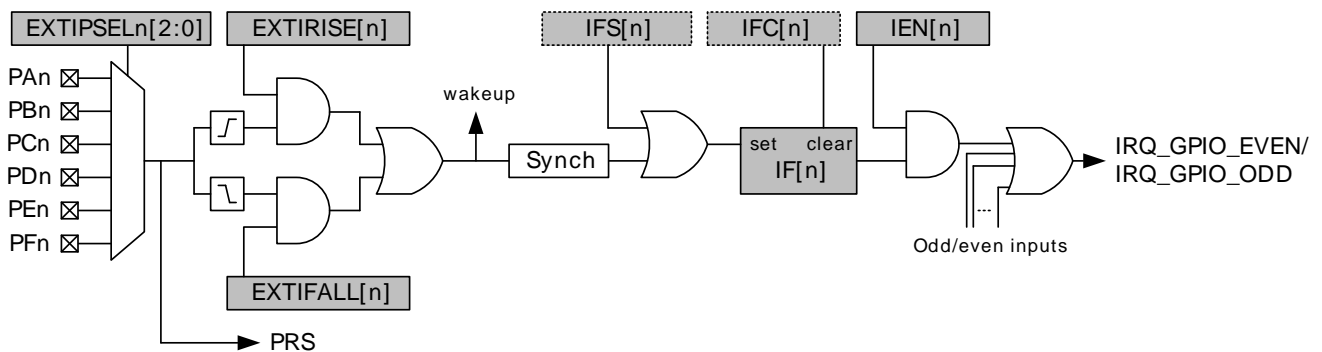

All pins with the same pin number (n) are grouped together to trigger one interrupt flag (EXT[n] in GPIO_IF). The EXTIPSEL n [2:0] bits in GPIO_EXTIPSELL or GPIO_EXTIPSELH select which port will trigger the interrupt flag. The GPIO_EXTIRISE[n] and GPIO_EXTIFALL[n] registers enables sensing of rising and falling edges. By setting the EXT[n] bit in GPIO_IEN, a high interrupt flag n , will trigger one of two interrupt lines. The even interrupt line is triggered by any enabled even numbered interrupt flag, while the odd is triggered by odd flags. The interrupt flags can be set and cleared by software by writing the GPIO_IFS and GPIO_IFC registers, see Example 28.1 (p. 397) . Since the external interrupts are asynchronous, they are sensitive to noise. To increase noise tolerance, the MODEL and MODEH fields in the GPIO_Px_MODEL and GPIO_Px_MODEH registers, respectively, should be set to include filtering for pins that have external interrupts enabled.

Example 28.1. Interrupt Example

Setting EXTIPSEL3 in GPIO_EXTIPSELL to 2 (Port C) and setting the GPIO_EXTIRISE[3] bit, the interrupt flag EXT[3] in GPIO_IF will be triggered by a rising edge on pin 3 on PORT C. If EXT[3] in GPIO_IEN is set as well, a interrupt request will be sent on IRQ_GPIO_ODD.

28.3.4 Output to PRS

All pins with the same pin number (n) are grouped together to form one PRS producer output, giving a total of 16 outputs to the PRS. The port on which the output n should be taken is selected by the EXTIPSELn[3:0] bits in the GPIO_EXTIPSELL or the GPIO_EXTIPSELH registers.

28.3.5 Synchronization

To avoid metastability in synchronous logic connected to the pins, all inputs are synchronized with double flip-flops. The flip-flops for the input data run on the HFCORECLK. Consequently, when a pin changes state, the change will have propagated to GPIO_Px_DIN after 2 positive HFCORECLK edges, or maximum 2 HFCORECLK cycles. Synchronization (also running on the HFCORECLK) is also added for interrupt input. The input to the PRS generation is also synchronized, but these flip-flops run on the HFPERCLK. To save power when the external interrupts or PRS generation is not used, the synchronization flip-flops for these can be turned off by clearing the INTSENSE or PRSSENSE, respectively, in GPIO_INSENSE register.

Note

To use the GPIO, the GPIO clock must first be enabled in CMU_HFPERCLKEN0. Setting this bit enables the HFCORECLK and the HFPERCLK for the GPIO. HFCORECLK is used for updating registers, while HFPERCLK is only used to synchronize PRS and interrupts. The PRS and interrupt synchronization can also be disabled through GPIO_INSENSE, if these are not used.

28.4 Register Map

The offset register address is relative to the registers base address.

Offset	Name	Type	Description
0x000	GPIO_PA_CTRL	RW	Port Control Register
0x004	GPIO_PA_MODEL	RW	Port Pin Mode Low Register
0x008	GPIO_PA_MODEH	RW	Port Pin Mode High Register
0x00C	GPIO_PA_DOUT	RW	Port Data Out Register
0x010	GPIO_PA_DOUTSET	W1	Port Data Out Set Register
0x014	GPIO_PA_DOUTCLR	W1	Port Data Out Clear Register
0x018	GPIO_PA_DOUTTGL	W1	Port Data Out Toggle Register
0x01C	GPIO_PA_DIN	R	Port Data In Register
0x020	GPIO_PA_PINLOCKN	RW	Port Unlocked Pins Register
0x024	GPIO_PB_CTRL	RW	Port Control Register
0x028	GPIO_PB_MODEL	RW	Port Pin Mode Low Register
0x02C	GPIO_PB_MODEH	RW	Port Pin Mode High Register
0x030	GPIO_PB_DOUT	RW	Port Data Out Register
0x034	GPIO_PB_DOUTSET	W1	Port Data Out Set Register
0x038	GPIO_PB_DOUTCLR	W1	Port Data Out Clear Register
0x03C	GPIO_PB_DOUTTGL	W1	Port Data Out Toggle Register
0x040	GPIO_PB_DIN	R	Port Data In Register
0x044	GPIO_PB_PINLOCKN	RW	Port Unlocked Pins Register
0x048	GPIO_PC_CTRL	RW	Port Control Register
0x04C	GPIO_PC_MODEL	RW	Port Pin Mode Low Register
0x050	GPIO_PC_MODEH	RW	Port Pin Mode High Register
0x054	GPIO_PC_DOUT	RW	Port Data Out Register
0x058	GPIO_PC_DOUTSET	W1	Port Data Out Set Register
0x05C	GPIO_PC_DOUTCLR	W1	Port Data Out Clear Register
0x060	GPIO_PC_DOUTTGL	W1	Port Data Out Toggle Register
0x064	GPIO_PC_DIN	R	Port Data In Register
0x068	GPIO_PC_PINLOCKN	RW	Port Unlocked Pins Register
0x06C	GPIO_PD_CTRL	RW	Port Control Register
0x070	GPIO_PD_MODEL	RW	Port Pin Mode Low Register
0x074	GPIO_PD_MODEH	RW	Port Pin Mode High Register
0x078	GPIO_PD_DOUT	RW	Port Data Out Register
0x07C	GPIO_PD_DOUTSET	W1	Port Data Out Set Register
0x080	GPIO_PD_DOUTCLR	W1	Port Data Out Clear Register
0x084	GPIO_PD_DOUTTGL	W1	Port Data Out Toggle Register
0x088	GPIO_PD_DIN	R	Port Data In Register
0x08C	GPIO_PD_PINLOCKN	RW	Port Unlocked Pins Register
0x090	GPIO_PE_CTRL	RW	Port Control Register
0x094	GPIO_PE_MODEL	RW	Port Pin Mode Low Register
0x098	GPIO_PE_MODEH	RW	Port Pin Mode High Register
0x09C	GPIO_PE_DOUT	RW	Port Data Out Register

Offset	Name	Type	Description
0x0A0	GPIO_PE_DOUTSET	W1	Port Data Out Set Register
0x0A4	GPIO_PE_DOUTCLR	W1	Port Data Out Clear Register
0x0A8	GPIO_PE_DOUTTGL	W1	Port Data Out Toggle Register
0x0AC	GPIO_PE_DIN	R	Port Data In Register
0x0B0	GPIO_PE_PINLOCKN	RW	Port Unlocked Pins Register
0x0B4	GPIO_PF_CTRL	RW	Port Control Register
0x0B8	GPIO_PF_MODEL	RW	Port Pin Mode Low Register
0x0BC	GPIO_PF_MODEH	RW	Port Pin Mode High Register
0x0C0	GPIO_PF_DOUT	RW	Port Data Out Register
0x0C4	GPIO_PF_DOUTSET	W1	Port Data Out Set Register
0x0C8	GPIO_PF_DOUTCLR	W1	Port Data Out Clear Register
0x0CC	GPIO_PF_DOUTTGL	W1	Port Data Out Toggle Register
0x0D0	GPIO_PF_DIN	R	Port Data In Register
0x0D4	GPIO_PF_PINLOCKN	RW	Port Unlocked Pins Register
0x100	GPIO_EXTIPSELL	RW	External Interrupt Port Select Low Register
0x104	GPIO_EXTIPSELH	RW	External Interrupt Port Select High Register
0x108	GPIO_EXTIRISE	RW	External Interrupt Rising Edge Trigger Register
0x10C	GPIO_EXTIFALL	RW	External Interrupt Falling Edge Trigger Register
0x110	GPIO_IEN	RW	Interrupt Enable Register
0x114	GPIO_IF	R	Interrupt Flag Register
0x118	GPIO_IFS	W1	Interrupt Flag Set Register
0x11C	GPIO_IFC	W1	Interrupt Flag Clear Register
0x120	GPIO_ROUTE	RW	I/O Routing Register
0x124	GPIO_INSENSE	RW	Input Sense Register
0x128	GPIO_LOCK	RW	Configuration Lock Register

28.5 Register Description

28.5.1 GPIO_Px_CTRL - Port Control Register

Offset	Bit Position																															
0x000	31	30	29	28	27	26	25	24	23	22	21	20	19	18	17	16	15	14	13	12	11	10	9	8	7	6	5	4	3	2	1	0
Reset																															1	0
Access																															RW	RW
Name																															DRIVEMODE	

Bit	Name	Reset	Access	Description
31:2	Reserved	To ensure compatibility with future devices, always write bits to 0. More information in Section 2.1 (p. 3)		
1:0	DRIVEMODE	0x0	RW	Drive Mode Select

Select drive mode for all pins on port configured with alternate drive strength.

Value	Mode	Description
0	STANDARD	6 mA drive current

Bit	Name	Reset	Access	Description
	Value	Mode		Description
1	LOWEST			0.5 mA drive current
2	HIGH			20 mA drive current
3	LOW			2 mA drive current

28.5.2 GPIO_Px_MODEL - Port Pin Mode Low Register

Offset	Bit Position																															
0x004	31	30	29	28	27	26	25	24	23	22	21	20	19	18	17	16	15	14	13	12	11	10	9	8	7	6	5	4	3	2	1	0
Reset	0x0				0x0				0x0				0x0				0x0				0x0				0x0							
Access	RW				RW				RW				RW				RW				RW											
Name	MODE7				MODE6				MODE5				MODE4				MODE3				MODE2				MODE1				MODE0			

Bit	Name	Reset	Access	Description
31:28	MODE7	0x0	RW	Pin 7 Mode Configure mode for pin 7. Enumeration is equal to MODE0.
27:24	MODE6	0x0	RW	Pin 6 Mode Configure mode for pin 6. Enumeration is equal to MODE0.
23:20	MODE5	0x0	RW	Pin 5 Mode Configure mode for pin 5. Enumeration is equal to MODE0.
19:16	MODE4	0x0	RW	Pin 4 Mode Configure mode for pin 4. Enumeration is equal to MODE0.
15:12	MODE3	0x0	RW	Pin 3 Mode Configure mode for pin 3. Enumeration is equal to MODE0.
11:8	MODE2	0x0	RW	Pin 2 Mode Configure mode for pin 2. Enumeration is equal to MODE0.
7:4	MODE1	0x0	RW	Pin 1 Mode Configure mode for pin 1. Enumeration is equal to MODE0.
3:0	MODE0	0x0	RW	Pin 0 Mode Configure mode for pin 0.

Value	Mode	Description
0	DISABLED	Input disabled. Pullup if DOUT is set.
1	INPUT	Input enabled. Filter if DOUT is set
2	INPUTPULL	Input enabled. DOUT determines pull direction
3	INPUTPULLFILTER	Input enabled with filter. DOUT determines pull direction
4	PUSHPULL	Push-pull output
5	PUSHPULLDRIVE	Push-pull output with drive-strength set by DRIVEMODE
6	WIREDOR	Wired-or output
7	WIREDORPULLDOWN	Wired-or output with pull-down
8	WIREDAND	Open-drain output
9	WIREDANDFILTER	Open-drain output with filter
10	WIREDANDPULLUP	Open-drain output with pullup
11	WIREDANDPULLUPFILTER	Open-drain output with filter and pullup
12	WIREDANDDRIVE	Open-drain output with drive-strength set by DRIVEMODE
13	WIREDANDDRIVEFILTER	Open-drain output with filter and drive-strength set by DRIVEMODE
14	WIREDANDDRIVEPULLUP	Open-drain output with pullup and drive-strength set by DRIVEMODE
15	WIREDANDDRIVEPULLUPFILTER	Open-drain output with filter, pullup and drive-strength set by DRIVEMODE

28.5.3 GPIO_Px_MODEH - Port Pin Mode High Register

Offset	Bit Position																															
0x008	31	30	29	28	27	26	25	24	23	22	21	20	19	18	17	16	15	14	13	12	11	10	9	8	7	6	5	4	3	2	1	0
Reset	0x0				0x0				0x0				0x0				0x0				0x0				0x0							
Access	RW				RW				RW				RW				RW				RW											
Name	MODE15				MODE14				MODE13				MODE12				MODE11				MODE10				MODE9				MODE8			

Bit	Name	Reset	Access	Description
31:28	MODE15	0x0	RW	Pin 15 Mode Configure mode for pin 15. Enumeration is equal to MODE8.
27:24	MODE14	0x0	RW	Pin 14 Mode Configure mode for pin 14. Enumeration is equal to MODE8.
23:20	MODE13	0x0	RW	Pin 13 Mode Configure mode for pin 13. Enumeration is equal to MODE8.
19:16	MODE12	0x0	RW	Pin 12 Mode Configure mode for pin 12. Enumeration is equal to MODE8.
15:12	MODE11	0x0	RW	Pin 11 Mode Configure mode for pin 11. Enumeration is equal to MODE8.
11:8	MODE10	0x0	RW	Pin 10 Mode Configure mode for pin 10. Enumeration is equal to MODE8.
7:4	MODE9	0x0	RW	Pin 9 Mode Configure mode for pin 9. Enumeration is equal to MODE8.
3:0	MODE8	0x0	RW	Pin 8 Mode Configure mode for pin 8.

Value	Mode	Description
0	DISABLED	Input disabled. Pullup if DOUT is set.
1	INPUT	Input enabled. Filter if DOUT is set
2	INPUTPULL	Input enabled. DOUT determines pull direction
3	INPUTPULLFILTER	Input enabled with filter. DOUT determines pull direction
4	PUSHPULL	Push-pull output
5	PUSHPULLDRIVE	Push-pull output with drive-strength set by DRIVEMODE
6	WIREDOR	Wired-or output
7	WIREDORPULLDOWN	Wired-or output with pull-down
8	WIREDAND	Open-drain output
9	WIREDANDFILTER	Open-drain output with filter
10	WIREDANDPULLUP	Open-drain output with pullup
11	WIREDANDPULLUPFILTER	Open-drain output with filter and pullup
12	WIREDANDDRIVE	Open-drain output with drive-strength set by DRIVEMODE
13	WIREDANDDRIVEFILTER	Open-drain output with filter and drive-strength set by DRIVEMODE
14	WIREDANDDRIVEPULLUP	Open-drain output with pullup and drive-strength set by DRIVEMODE
15	WIREDANDDRIVEPULLUPFILTER	Open-drain output with filter, pullup and drive-strength set by DRIVEMODE

28.5.4 GPIO_Px_DOUT - Port Data Out Register

Offset	Bit Position																															
0x00C	31	30	29	28	27	26	25	24	23	22	21	20	19	18	17	16	15	14	13	12	11	10	9	8	7	6	5	4	3	2	1	0
Reset																	0x0000															
Access																	RW															
Name																	DOUT															

Bit	Name	Reset	Access	Description
31:16	Reserved	To ensure compatibility with future devices, always write bits to 0. More information in Section 2.1 (p. 3)		
15:0	DOUT	0x0000	RW	Data Out Data output on port.

28.5.5 GPIO_Px_DOUTSET - Port Data Out Set Register

Offset	Bit Position																															
0x010	31	30	29	28	27	26	25	24	23	22	21	20	19	18	17	16	15	14	13	12	11	10	9	8	7	6	5	4	3	2	1	0
Reset																	0x0000															
Access																	W1															
Name																	DOUTSET															

Bit	Name	Reset	Access	Description
31:16	Reserved	To ensure compatibility with future devices, always write bits to 0. More information in Section 2.1 (p. 3)		
15:0	DOUTSET	0x0000	W1	Data Out Set Write bits to 1 to set corresponding bits in GPIO_Px_DOUT. Bits written to 0 will have no effect.

28.5.6 GPIO_Px_DOUTCLR - Port Data Out Clear Register

Offset	Bit Position																															
0x014	31	30	29	28	27	26	25	24	23	22	21	20	19	18	17	16	15	14	13	12	11	10	9	8	7	6	5	4	3	2	1	0
Reset																	0x0000															
Access																	W1															
Name																	DOUTCLR															

Bit	Name	Reset	Access	Description
31:16	Reserved	To ensure compatibility with future devices, always write bits to 0. More information in Section 2.1 (p. 3)		
15:0	DOUTCLR	0x0000	W1	Data Out Clear Write bits to 1 to clear corresponding bits in GPIO_Px_DOUT. Bits written to 0 will have no effect.

28.5.7 GPIO_Px_DOUTTGL - Port Data Out Toggle Register

Offset	Bit Position																																
0x018	31	30	29	28	27	26	25	24	23	22	21	20	19	18	17	16	15	14	13	12	11	10	9	8	7	6	5	4	3	2	1	0	
Reset																																	0x0000
Access																																	W1
Name																																	DOUTTGL

Bit	Name	Reset	Access	Description
31:16	Reserved	To ensure compatibility with future devices, always write bits to 0. More information in Section 2.1 (p. 3)		
15:0	DOUTTGL	0x0000	W1	Data Out Toggle Write bits to 1 to toggle corresponding bits in GPIO_Px_DOUT. Bits written to 0 will have no effect.

28.5.8 GPIO_Px_DIN - Port Data In Register

Offset	Bit Position																																
0x01C	31	30	29	28	27	26	25	24	23	22	21	20	19	18	17	16	15	14	13	12	11	10	9	8	7	6	5	4	3	2	1	0	
Reset																																	0x0000
Access																																	R
Name																																	DIN

Bit	Name	Reset	Access	Description
31:16	Reserved	To ensure compatibility with future devices, always write bits to 0. More information in Section 2.1 (p. 3)		
15:0	DIN	0x0000	R	Data In Port data input.

28.5.9 GPIO_Px_PINLOCKN - Port Unlocked Pins Register

Offset	Bit Position																															
0x020	31	30	29	28	27	26	25	24	23	22	21	20	19	18	17	16	15	14	13	12	11	10	9	8	7	6	5	4	3	2	1	0
Reset																	0xFFFF															
Access																	RW															
Name																	PINLOCKN															

Bit	Name	Reset	Access	Description
31:16	Reserved	To ensure compatibility with future devices, always write bits to 0. More information in Section 2.1 (p. 3)		
15:0	PINLOCKN	0xFFFF	RW	Unlocked Pins Shows unlocked pins in the port. To lock pin n, clear bit n. The pin is then locked until reset.

28.5.10 GPIO_EXTIPSELL - External Interrupt Port Select Low Register

Offset	Bit Position																															
0x100	31	30	29	28	27	26	25	24	23	22	21	20	19	18	17	16	15	14	13	12	11	10	9	8	7	6	5	4	3	2	1	0
Reset			0x0				0x0				0x0				0x0				0x0				0x0				0x0				0x0	
Access			RW				RW				RW				RW				RW				RW				RW				RW	
Name			EXTIPSEL7				EXTIPSEL6				EXTIPSEL5				EXTIPSEL4				EXTIPSEL3				EXTIPSEL2				EXTIPSEL1				EXTIPSEL0	

Bit	Name	Reset	Access	Description																					
31	Reserved	To ensure compatibility with future devices, always write bits to 0. More information in Section 2.1 (p. 3)																							
30:28	EXTIPSEL7	0x0	RW	External Interrupt 7 Port Select Select input port for external interrupt 7. <table border="1"> <thead> <tr> <th>Value</th> <th>Mode</th> <th>Description</th> </tr> </thead> <tbody> <tr> <td>0</td> <td>PORTA</td> <td>Port A pin 7 selected for external interrupt 7</td> </tr> <tr> <td>1</td> <td>PORTB</td> <td>Port B pin 7 selected for external interrupt 7</td> </tr> <tr> <td>2</td> <td>PORTC</td> <td>Port C pin 7 selected for external interrupt 7</td> </tr> <tr> <td>3</td> <td>PORTD</td> <td>Port D pin 7 selected for external interrupt 7</td> </tr> <tr> <td>4</td> <td>PORTE</td> <td>Port E pin 7 selected for external interrupt 7</td> </tr> <tr> <td>5</td> <td>PORTF</td> <td>Port F pin 7 selected for external interrupt 7</td> </tr> </tbody> </table>	Value	Mode	Description	0	PORTA	Port A pin 7 selected for external interrupt 7	1	PORTB	Port B pin 7 selected for external interrupt 7	2	PORTC	Port C pin 7 selected for external interrupt 7	3	PORTD	Port D pin 7 selected for external interrupt 7	4	PORTE	Port E pin 7 selected for external interrupt 7	5	PORTF	Port F pin 7 selected for external interrupt 7
Value	Mode	Description																							
0	PORTA	Port A pin 7 selected for external interrupt 7																							
1	PORTB	Port B pin 7 selected for external interrupt 7																							
2	PORTC	Port C pin 7 selected for external interrupt 7																							
3	PORTD	Port D pin 7 selected for external interrupt 7																							
4	PORTE	Port E pin 7 selected for external interrupt 7																							
5	PORTF	Port F pin 7 selected for external interrupt 7																							
27	Reserved	To ensure compatibility with future devices, always write bits to 0. More information in Section 2.1 (p. 3)																							
26:24	EXTIPSEL6	0x0	RW	External Interrupt 6 Port Select Select input port for external interrupt 6. <table border="1"> <thead> <tr> <th>Value</th> <th>Mode</th> <th>Description</th> </tr> </thead> <tbody> <tr> <td>0</td> <td>PORTA</td> <td>Port A pin 6 selected for external interrupt 6</td> </tr> <tr> <td>1</td> <td>PORTB</td> <td>Port B pin 6 selected for external interrupt 6</td> </tr> <tr> <td>2</td> <td>PORTC</td> <td>Port C pin 6 selected for external interrupt 6</td> </tr> <tr> <td>3</td> <td>PORTD</td> <td>Port D pin 6 selected for external interrupt 6</td> </tr> <tr> <td>4</td> <td>PORTE</td> <td>Port E pin 6 selected for external interrupt 6</td> </tr> <tr> <td>5</td> <td>PORTF</td> <td>Port F pin 6 selected for external interrupt 6</td> </tr> </tbody> </table>	Value	Mode	Description	0	PORTA	Port A pin 6 selected for external interrupt 6	1	PORTB	Port B pin 6 selected for external interrupt 6	2	PORTC	Port C pin 6 selected for external interrupt 6	3	PORTD	Port D pin 6 selected for external interrupt 6	4	PORTE	Port E pin 6 selected for external interrupt 6	5	PORTF	Port F pin 6 selected for external interrupt 6
Value	Mode	Description																							
0	PORTA	Port A pin 6 selected for external interrupt 6																							
1	PORTB	Port B pin 6 selected for external interrupt 6																							
2	PORTC	Port C pin 6 selected for external interrupt 6																							
3	PORTD	Port D pin 6 selected for external interrupt 6																							
4	PORTE	Port E pin 6 selected for external interrupt 6																							
5	PORTF	Port F pin 6 selected for external interrupt 6																							

Bit	Name	Reset	Access	Description
23	Reserved	To ensure compatibility with future devices, always write bits to 0. More information in Section 2.1 (p. 3)		

22:20 EXTIPSEL5 0x0 RW **External Interrupt 5 Port Select**

Select input port for external interrupt 5.

Value	Mode	Description
0	PORTA	Port A pin 5 selected for external interrupt 5
1	PORTB	Port B pin 5 selected for external interrupt 5
2	PORTC	Port C pin 5 selected for external interrupt 5
3	PORTD	Port D pin 5 selected for external interrupt 5
4	PORTE	Port E pin 5 selected for external interrupt 5
5	PORTF	Port F pin 5 selected for external interrupt 5

19	Reserved	To ensure compatibility with future devices, always write bits to 0. More information in Section 2.1 (p. 3)		
----	----------	---	--	--

18:16 EXTIPSEL4 0x0 RW **External Interrupt 4 Port Select**

Select input port for external interrupt 4.

Value	Mode	Description
0	PORTA	Port A pin 4 selected for external interrupt 4
1	PORTB	Port B pin 4 selected for external interrupt 4
2	PORTC	Port C pin 4 selected for external interrupt 4
3	PORTD	Port D pin 4 selected for external interrupt 4
4	PORTE	Port E pin 4 selected for external interrupt 4
5	PORTF	Port F pin 4 selected for external interrupt 4

15	Reserved	To ensure compatibility with future devices, always write bits to 0. More information in Section 2.1 (p. 3)		
----	----------	---	--	--

14:12 EXTIPSEL3 0x0 RW **External Interrupt 3 Port Select**

Select input port for external interrupt 3.

Value	Mode	Description
0	PORTA	Port A pin 3 selected for external interrupt 3
1	PORTB	Port B pin 3 selected for external interrupt 3
2	PORTC	Port C pin 3 selected for external interrupt 3
3	PORTD	Port D pin 3 selected for external interrupt 3
4	PORTE	Port E pin 3 selected for external interrupt 3
5	PORTF	Port F pin 3 selected for external interrupt 3

11	Reserved	To ensure compatibility with future devices, always write bits to 0. More information in Section 2.1 (p. 3)		
----	----------	---	--	--

10:8 EXTIPSEL2 0x0 RW **External Interrupt 2 Port Select**

Select input port for external interrupt 2.

Value	Mode	Description
0	PORTA	Port A pin 2 selected for external interrupt 2
1	PORTB	Port B pin 2 selected for external interrupt 2
2	PORTC	Port C pin 2 selected for external interrupt 2
3	PORTD	Port D pin 2 selected for external interrupt 2
4	PORTE	Port E pin 2 selected for external interrupt 2
5	PORTF	Port F pin 2 selected for external interrupt 2

7	Reserved	To ensure compatibility with future devices, always write bits to 0. More information in Section 2.1 (p. 3)		
---	----------	---	--	--

6:4 EXTIPSEL1 0x0 RW **External Interrupt 1 Port Select**

Select input port for external interrupt 1.

Value	Mode	Description
0	PORTA	Port A pin 1 selected for external interrupt 1
1	PORTB	Port B pin 1 selected for external interrupt 1
2	PORTC	Port C pin 1 selected for external interrupt 1
3	PORTD	Port D pin 1 selected for external interrupt 1
4	PORTE	Port E pin 1 selected for external interrupt 1

Bit	Name	Reset	Access	Description
	Value	Mode		Description
	5	PORTF		Port F pin 1 selected for external interrupt 1
3	<i>Reserved To ensure compatibility with future devices, always write bits to 0. More information in Section 2.1 (p. 3)</i>			
2:0	EXTIPSEL0	0x0	RW	External Interrupt 0 Port Select Select input port for external interrupt 0.
	Value	Mode		Description
	0	PORTA		Port A pin 0 selected for external interrupt 0
	1	PORTB		Port B pin 0 selected for external interrupt 0
	2	PORTC		Port C pin 0 selected for external interrupt 0
	3	PORTD		Port D pin 0 selected for external interrupt 0
	4	PORTE		Port E pin 0 selected for external interrupt 0
	5	PORTF		Port F pin 0 selected for external interrupt 0

28.5.11 GPIO_EXTIPSELH - External Interrupt Port Select High Register

Offset	Bit Position																																
0x104	31	30	29	28	27	26	25	24	23	22	21	20	19	18	17	16	15	14	13	12	11	10	9	8	7	6	5	4	3	2	1	0	
Reset			0x0				0x0				0x0				0x0				0x0				0x0				0x0				0x0		
Access			RW				RW				RW				RW				RW				RW				RW				RW		
Name			EXTIPSEL15				EXTIPSEL14				EXTIPSEL13				EXTIPSEL12				EXTIPSEL11				EXTIPSEL10				EXTIPSEL9				EXTIPSEL8		

Bit	Name	Reset	Access	Description
31	<i>Reserved To ensure compatibility with future devices, always write bits to 0. More information in Section 2.1 (p. 3)</i>			
30:28	EXTIPSEL15	0x0	RW	External Interrupt 15 Port Select Select input port for external interrupt 15.
	Value	Mode		Description
	0	PORTA		Port A pin 15 selected for external interrupt 15
	1	PORTB		Port B pin 15 selected for external interrupt 15
	2	PORTC		Port C pin 15 selected for external interrupt 15
	3	PORTD		Port D pin 15 selected for external interrupt 15
	4	PORTE		Port E pin 15 selected for external interrupt 15
	5	PORTF		Port F pin 15 selected for external interrupt 15
27	<i>Reserved To ensure compatibility with future devices, always write bits to 0. More information in Section 2.1 (p. 3)</i>			
26:24	EXTIPSEL14	0x0	RW	External Interrupt 14 Port Select Select input port for external interrupt 14.
	Value	Mode		Description
	0	PORTA		Port A pin 14 selected for external interrupt 14
	1	PORTB		Port B pin 14 selected for external interrupt 14
	2	PORTC		Port C pin 14 selected for external interrupt 14
	3	PORTD		Port D pin 14 selected for external interrupt 14
	4	PORTE		Port E pin 14 selected for external interrupt 14
	5	PORTF		Port F pin 14 selected for external interrupt 14
23	<i>Reserved To ensure compatibility with future devices, always write bits to 0. More information in Section 2.1 (p. 3)</i>			
22:20	EXTIPSEL13	0x0	RW	External Interrupt 13 Port Select Select input port for external interrupt 13.

Bit	Name	Reset	Access	Description
	Value	Mode		Description
	0	PORTA		Port A pin 13 selected for external interrupt 13
	1	PORTB		Port B pin 13 selected for external interrupt 13
	2	PORTC		Port C pin 13 selected for external interrupt 13
	3	PORTD		Port D pin 13 selected for external interrupt 13
	4	PORTE		Port E pin 13 selected for external interrupt 13
	5	PORTF		Port F pin 13 selected for external interrupt 13
19	<i>Reserved</i> To ensure compatibility with future devices, always write bits to 0. More information in Section 2.1 (p. 3)			
18:16	EXTIPSEL12	0x0	RW	External Interrupt 12 Port Select
	Select input port for external interrupt 12.			
	Value	Mode		Description
	0	PORTA		Port A pin 12 selected for external interrupt 12
	1	PORTB		Port B pin 12 selected for external interrupt 12
	2	PORTC		Port C pin 12 selected for external interrupt 12
	3	PORTD		Port D pin 12 selected for external interrupt 12
	4	PORTE		Port E pin 12 selected for external interrupt 12
	5	PORTF		Port F pin 12 selected for external interrupt 12
15	<i>Reserved</i> To ensure compatibility with future devices, always write bits to 0. More information in Section 2.1 (p. 3)			
14:12	EXTIPSEL11	0x0	RW	External Interrupt 11 Port Select
	Select input port for external interrupt 11.			
	Value	Mode		Description
	0	PORTA		Port A pin 11 selected for external interrupt 11
	1	PORTB		Port B pin 11 selected for external interrupt 11
	2	PORTC		Port C pin 11 selected for external interrupt 11
	3	PORTD		Port D pin 11 selected for external interrupt 11
	4	PORTE		Port E pin 11 selected for external interrupt 11
	5	PORTF		Port F pin 11 selected for external interrupt 11
11	<i>Reserved</i> To ensure compatibility with future devices, always write bits to 0. More information in Section 2.1 (p. 3)			
10:8	EXTIPSEL10	0x0	RW	External Interrupt 10 Port Select
	Select input port for external interrupt 10.			
	Value	Mode		Description
	0	PORTA		Port A pin 10 selected for external interrupt 10
	1	PORTB		Port B pin 10 selected for external interrupt 10
	2	PORTC		Port C pin 10 selected for external interrupt 10
	3	PORTD		Port D pin 10 selected for external interrupt 10
	4	PORTE		Port E pin 10 selected for external interrupt 10
	5	PORTF		Port F pin 10 selected for external interrupt 10
7	<i>Reserved</i> To ensure compatibility with future devices, always write bits to 0. More information in Section 2.1 (p. 3)			
6:4	EXTIPSEL9	0x0	RW	External Interrupt 9 Port Select
	Select input port for external interrupt 9.			
	Value	Mode		Description
	0	PORTA		Port A pin 9 selected for external interrupt 9
	1	PORTB		Port B pin 9 selected for external interrupt 9
	2	PORTC		Port C pin 9 selected for external interrupt 9
	3	PORTD		Port D pin 9 selected for external interrupt 9
	4	PORTE		Port E pin 9 selected for external interrupt 9
	5	PORTF		Port F pin 9 selected for external interrupt 9
3	<i>Reserved</i> To ensure compatibility with future devices, always write bits to 0. More information in Section 2.1 (p. 3)			
2:0	EXTIPSEL8	0x0	RW	External Interrupt 8 Port Select

Bit	Name	Reset	Access	Description
Select input port for external interrupt 8.				
	Value	Mode		Description
	0	PORTA		Port A pin 8 selected for external interrupt 8
	1	PORTB		Port B pin 8 selected for external interrupt 8
	2	PORTC		Port C pin 8 selected for external interrupt 8
	3	PORTD		Port D pin 8 selected for external interrupt 8
	4	PORTE		Port E pin 8 selected for external interrupt 8
	5	PORTF		Port F pin 8 selected for external interrupt 8

28.5.12 GPIO_EXTIRISE - External Interrupt Rising Edge Trigger Register

Offset	Bit Position																															
0x108	31	30	29	28	27	26	25	24	23	22	21	20	19	18	17	16	15	14	13	12	11	10	9	8	7	6	5	4	3	2	1	0
Reset																	0x0000															
Access																	RW															
Name																	EXTIRISE															

Bit	Name	Reset	Access	Description
31:16	Reserved	<i>To ensure compatibility with future devices, always write bits to 0. More information in Section 2.1 (p. 3)</i>		
15:0	EXTIRISE	0x0000	RW	External Interrupt n Rising Edge Trigger Enable
Set bit n to enable triggering of external interrupt n on rising edge.				
	Value	Description		
	EXTIRISE[n] = 0	Rising edge trigger disabled		
	EXTIRISE[n] = 1	Rising edge trigger enabled		

28.5.13 GPIO_EXTIFALL - External Interrupt Falling Edge Trigger Register

Offset	Bit Position																															
0x10C	31	30	29	28	27	26	25	24	23	22	21	20	19	18	17	16	15	14	13	12	11	10	9	8	7	6	5	4	3	2	1	0
Reset																	0x0000															
Access																	RW															
Name																	EXTIFALL															

Bit	Name	Reset	Access	Description
31:16	Reserved	<i>To ensure compatibility with future devices, always write bits to 0. More information in Section 2.1 (p. 3)</i>		
15:0	EXTIFALL	0x0000	RW	External Interrupt n Falling Edge Trigger Enable

Bit	Name	Reset	Access	Description
Set bit n to enable triggering of external interrupt n on falling edge.				
Value		Description		
EXTIFALL[n] = 0		Falling edge trigger disabled		
EXTIFALL[n] = 1		Falling edge trigger enabled		

28.5.14 GPIO_IEN - Interrupt Enable Register

Offset	Bit Position																															
0x110	31	30	29	28	27	26	25	24	23	22	21	20	19	18	17	16	15	14	13	12	11	10	9	8	7	6	5	4	3	2	1	0
Reset																	0x0000															
Access																	RW															
Name																	EXT															

Bit	Name	Reset	Access	Description
31:16	Reserved	To ensure compatibility with future devices, always write bits to 0. More information in Section 2.1 (p. 3)		
15:0	EXT	0x0000	RW	External Interrupt n Enable
Set bit n to enable external interrupt from pin n.				
Value		Description		
EXT[n] = 0		Pin n external interrupt disabled		
EXT[n] = 1		Pin n external interrupt enabled		

28.5.15 GPIO_IF - Interrupt Flag Register

Offset	Bit Position																															
0x114	31	30	29	28	27	26	25	24	23	22	21	20	19	18	17	16	15	14	13	12	11	10	9	8	7	6	5	4	3	2	1	0
Reset																	0x0000															
Access																	R															
Name																	EXT															

Bit	Name	Reset	Access	Description
31:16	Reserved	To ensure compatibility with future devices, always write bits to 0. More information in Section 2.1 (p. 3)		
15:0	EXT	0x0000	R	External Interrupt Flag n
Pin n external interrupt flag.				
Value		Description		
EXT[n] = 0		Pin n external interrupt flag cleared		

Bit	Name	Reset	Access	Description
	Value			Description
	EXT[n] = 1			Pin n external interrupt flag set

28.5.16 GPIO_IFS - Interrupt Flag Set Register

Offset	Bit Position																															
0x118	31	30	29	28	27	26	25	24	23	22	21	20	19	18	17	16	15	14	13	12	11	10	9	8	7	6	5	4	3	2	1	0
Reset																	0x0000															
Access																	W1															
Name																	EXT															

Bit	Name	Reset	Access	Description
31:16	Reserved	To ensure compatibility with future devices, always write bits to 0. More information in Section 2.1 (p. 3)		
15:0	EXT	0x0000	W1	External Interrupt Flag n Set Write bit n to 1 to set interrupt flag n.
	Value			Description
	EXT[n] = 0			Pin n external interrupt flag unchanged
	EXT[n] = 1			Pin n external interrupt flag set

28.5.17 GPIO_IFC - Interrupt Flag Clear Register

Offset	Bit Position																															
0x11C	31	30	29	28	27	26	25	24	23	22	21	20	19	18	17	16	15	14	13	12	11	10	9	8	7	6	5	4	3	2	1	0
Reset																	0x0000															
Access																	W1															
Name																	EXT															

Bit	Name	Reset	Access	Description
31:16	Reserved	To ensure compatibility with future devices, always write bits to 0. More information in Section 2.1 (p. 3)		
15:0	EXT	0x0000	W1	External Interrupt Flag Clear Write bit n to 1 to clear external interrupt flag n.
	Value			Description
	EXT[n] = 0			Pin n external interrupt flag unchanged
	EXT[n] = 1			Pin n external interrupt flag cleared

28.5.18 GPIO_ROUTE - I/O Routing Register

Offset	Bit Position																																		
0x120	31	30	29	28	27	26	25	24	23	22	21	20	19	18	17	16	15	14	13	12	11	10	9	8	7	6	5	4	3	2	1	0			
Reset																									0x0								0	1	1
Access																									RW								RW	RW	RW
Name																									SWLOCATION								SWOPEN	SWDIOPEN	SWCLKPEN

Bit	Name	Reset	Access	Description															
31:10	Reserved	To ensure compatibility with future devices, always write bits to 0. More information in Section 2.1 (p. 3)																	
9:8	SWLOCATION	0x0	RW	I/O Location Decides the location of the SW pins. <table border="1"> <thead> <tr> <th>Value</th> <th>Mode</th> <th>Description</th> </tr> </thead> <tbody> <tr> <td>0</td> <td>LOC0</td> <td>Location 0</td> </tr> <tr> <td>1</td> <td>LOC1</td> <td>Location 1</td> </tr> <tr> <td>2</td> <td>LOC2</td> <td>Location 2</td> </tr> <tr> <td>3</td> <td>LOC3</td> <td>Location 3</td> </tr> </tbody> </table>	Value	Mode	Description	0	LOC0	Location 0	1	LOC1	Location 1	2	LOC2	Location 2	3	LOC3	Location 3
Value	Mode	Description																	
0	LOC0	Location 0																	
1	LOC1	Location 1																	
2	LOC2	Location 2																	
3	LOC3	Location 3																	
7:3	Reserved	To ensure compatibility with future devices, always write bits to 0. More information in Section 2.1 (p. 3)																	
2	SWOPEN	0	RW	Serial Wire Viewer Output Pin Enable Enable Serial Wire Viewer Output connection to pin.															
1	SWDIOPEN	1	RW	Serial Wire Data Pin Enable Enable Serial Wire Data connection to pin. WARNING: When this pin is disabled, the device can no longer be accessed by a debugger. A reset will set the pin back to a default state as enabled. If you disable this pin, make sure you have at least a 3 second timeout at the start of you program code before you disable the pin. This way, the debugger will have time to halt the device after a reset before the pin is disabled.															
0	SWCLKPEN	1	RW	Serial Wire Clock Pin Enable Enable Serial Wire Clock connection to pin. WARNING: When this pin is disabled, the device can no longer be accessed by a debugger. A reset will set the pin back to a default state as enabled. If you disable this pin, make sure you have at least a 3 second timeout at the start of you program code before you disable the pin. This way, the debugger will have time to halt the device after a reset before the pin is disabled.															

28.5.19 GPIO_INSENSE - Input Sense Register

Offset	Bit Position																															
0x124	31	30	29	28	27	26	25	24	23	22	21	20	19	18	17	16	15	14	13	12	11	10	9	8	7	6	5	4	3	2	1	0
Reset																											1		1			
Access																											RW		RW			
Name																											PRS		INT			

Bit	Name	Reset	Access	Description
31:2	Reserved	To ensure compatibility with future devices, always write bits to 0. More information in Section 2.1 (p. 3)		
1	PRS	1	RW	PRS Sense Enable Set this bit to enable input sensing for PRS.
0	INT	1	RW	Interrupt Sense Enable

Bit	Name	Reset	Access	Description
Set this bit to enable input sensing for interrupts.				

28.5.20 GPIO_LOCK - Configuration Lock Register

Offset	Bit Position																															
0x128	31	30	29	28	27	26	25	24	23	22	21	20	19	18	17	16	15	14	13	12	11	10	9	8	7	6	5	4	3	2	1	0
Reset																	0x0000															
Access																	RW															
Name																	LOCKKEY															

Bit	Name	Reset	Access	Description
31:16	Reserved	To ensure compatibility with future devices, always write bits to 0. More information in Section 2.1 (p. 3)		

15:0 LOCKKEY 0x0000 RW **Configuration Lock Key**

Write any other value than the unlock code to lock MODEL, MODEH, CTRL, PINLOCKN, EPISELL, EIPSELH, INSENSE and SWDPROUTE from editing. Write the unlock code to unlock. When reading the register, bit 0 is set when the lock is enabled.

Mode	Value	Description
Read Operation		
UNLOCKED	0	GPIO registers are unlocked
LOCKED	1	GPIO registers are locked
Write Operation		
LOCK	0	Lock GPIO registers
UNLOCK	0xA534	Unlock GPIO registers

29 LCD - Liquid Crystal Display Driver

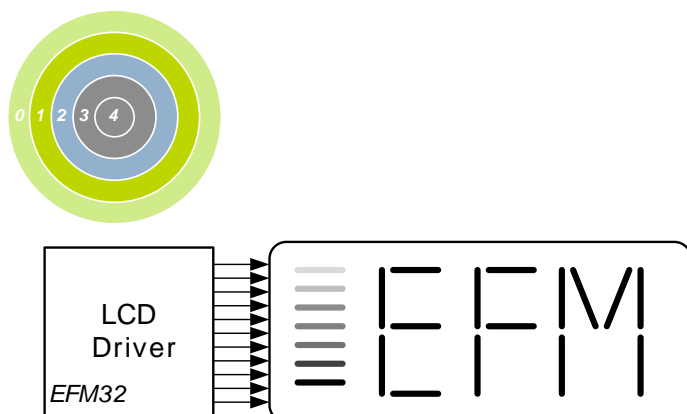

Quick Facts

What?

The LCD driver can drive up to 4x40 segmented LCD directly. The LCD driver consumes less than 900 nA in EM2. The animation feature makes it possible to have active animations without CPU intervention.

Why?

Segmented LCD displays are common way to display information. The extreme low-power LCD driver enables a lot of applications to utilize an LCD display even in energy critical systems.

How?

The low frequency clock signal, low-power waveform, animation and blink capabilities enable the LCD driver to run autonomously in EM2 for long periods. Adding the flexible frame rate setting, contrast control, and different multiplexing modes make the EFM32G the optimal choice for battery-driven systems with LCD panels.

29.1 Introduction

The LCD driver is capable of driving a segmented LCD display with up to 4x40 segments. A voltage boost function enables it to provide the LCD display with higher voltage than the supply voltage for the device. In addition, an animation feature can run custom animations on the LCD display without any CPU intervention. The LCD driver can also remain active even in Energy Mode 2 and provides a Frame Counter interrupt that can wake-up the device on a regular basis for updating data.

29.2 Features

- Up to 4x40 segments.
- Configurable multiplexing (1, 2, 3, 4)
- Configurable bias/voltage levels settings
- Configurable clock source prescaler
- Configurable Framerate
- Segment lines can be enabled or disabled in groups of 4
- Blink capabilities
- Integrated animation functionality
- Voltage boost capabilities
- Possible to run on external power
- Programmable contrast
- Frame Counter
- LCD frame interrupt
- Direct segment control

29.3 Functional Description

An overview of the LCD module is shown in Figure 29.1 (p. 415). In its simplest form, an LCD driver would apply a voltage above a certain threshold voltage in order to darken a segment and a voltage below threshold to make a segment clear. However, the LCD display segment will degrade if the applied voltage has a DC-component. To avoid this, the applied waveforms are arranged such that the differential voltage seen by each segment has an average value of zero, and such that the RMS voltage (or differential sum of the two waveforms for fast response LCDs) is below the segment threshold voltage if the segment shall be transparent, and above the segment threshold voltage when the segment shall be dark.

The waveforms are multiplexed between four different common lines and 40 segment lines to support up to 160 different LCD segments. The common lines and segment lines can be enabled or disabled individually to prevent the LCD driver from occupying more I/O resources than required.

Figure 29.1. LCD Block Diagram

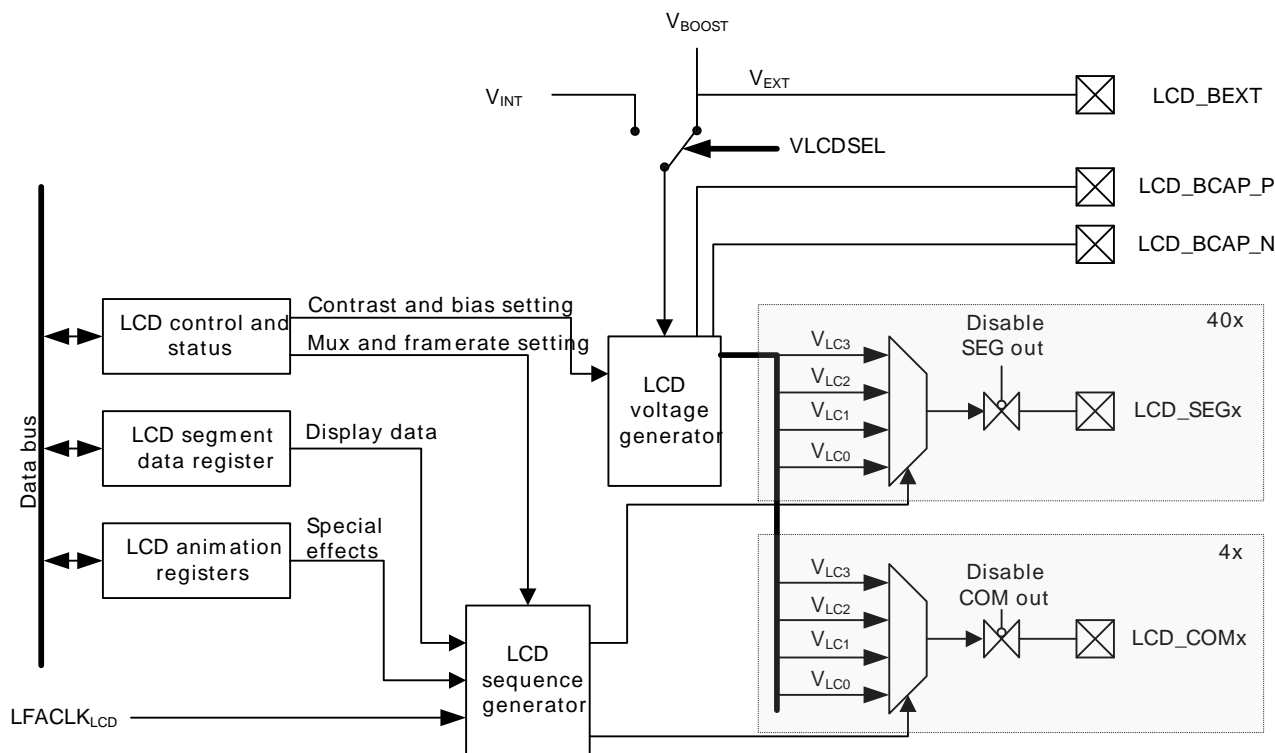

For simplicity, only one segment pin and one common terminal is shown in the figure.

29.3.1 LCD Driver Enable

Setting the EN bit in LCD_CTRL enables the LCD driver. The MUX bitfield in LCD_DISPCTRL determines which COM lines are driven by the LCD driver. By default, LCD_COM0 is driven whenever the LCD driver is enabled.

The LCD_SEGEN register determines which segment lines are enabled. Segment lines can be enabled or disabled in groups of 4.

Each LCD segment pin can also be individually disabled by setting the pin to any other state than DISABLED in the GPIO pin configuration. Note that this feature is not available on EFM32G revisions A and B.

29.3.2 Multiplexing, Bias, and Wave Settings

The LCD driver supports different multiplexing and bias settings, and these can be set individually in the MUX and BIAS bits in LCD_DISPCTRL respectively, see Table 29.1 (p. 416) and Table 29.2 (p. 416).

Note

If the MUX and BIAS settings in LCD_DISPCTRL are changed while the LCD driver is enabled, the output waveform is unpredictable and may lead to a DC-component for one LCD frame.

The MUX setting determines the number of LCD COM lines that are enabled. When static multiplexing is selected, LCD output is enabled on LCD_COM0, when duplex multiplexing is used, LCD_COM0-LCD_COM1 are used, when triplex multiplexing is selected, LCD_COM0-LCD_COM2 are used, and finally when quadruplex multiplexing is selected, all COM lines are driven by the LCD driver.

See Section 29.3.3 (p. 417) for waveforms for the different bias and multiplexing settings.

The waveforms generated by the LCD controller can be generated in two different versions, regular and low-power. The low power mode waveforms have a lower switching frequency than the regular waveforms, and thus consume less power. The WAVE bit in LCD_DISPCTRL decides which waveforms to generate. An example of a low-power waveform is shown in Figure 29.2 (p. 416), and an example of a regular waveform is shown in Figure 29.3 (p. 417).

Table 29.1. LCD Mux Settings

MUX	Mode	Multiplexing	
00	0	Static	Static (segments can be multiplexed with LCD_COM[0])
01	0	Duplex	Duplex (segments can be multiplexed with LCD_COM[1:0])
10	0	Triplex	Triplex (segments can be multiplexed with LCD_COM[2:0])
11	0	Quadruplex	Quadruplex (segments can be multiplexed with LCD_COM[3:0])

Table 29.2. LCD BIAS Settings

BIAS	Mode	Bias setting
00	Static	Static (2 levels)
01	Half Bias	1/2 Bias (3 levels)
10	Third Bias	1/3 Bias (4 levels)
11	Reserved	Reserved

Table 29.3. LCD Wave Settings

WAVE	Mode	Wave mode
0	LowPower	Low power optimized waveform output
1	Normal	Regular waveform output

Figure 29.2. LCD Low-power Waveform for LCD_COM0 in Quadruples Multiplex Mode, 1/3 Bias

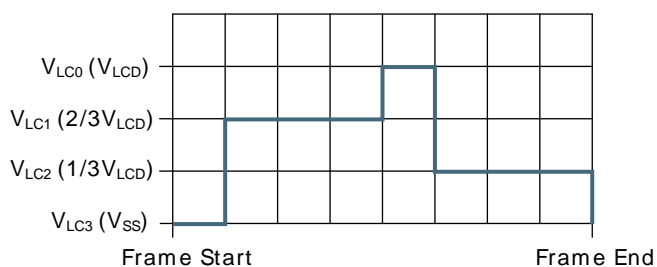
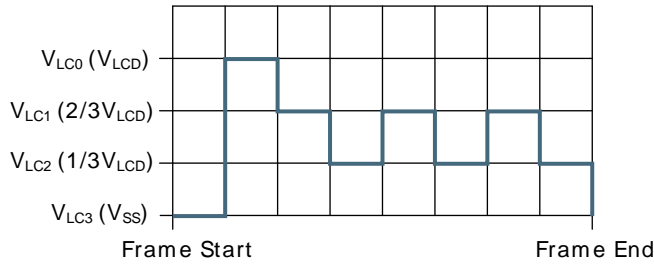

Figure 29.3. LCD Normal Waveform for LCD_COM0 in Quadruples Multiplex Mode, 1/3 Bias



29.3.3 Waveform Examples

The numbers on the illustration's y-axes in the following sections only indicate different voltage levels. All examples are shown with low-power waveforms.

29.3.3.1 Waveforms with Static Bias and Multiplexing

- With static bias and multiplexing, each segment line can be connected to LCD_COM0. When the segment line has the same waveform as LCD_COM0, the LCD panel pixel is turned off, while when the segment line has the opposite waveform, the LCD panel pixel is turned on.
- DC voltage = 0 (over one frame)
- $V_{RMS} (on) = V_{LCD_OUT}$
- $V_{RMS} (off) = 0 (V_{SS})$

Figure 29.4. LCD Static Bias and Multiplexing - LCD_COM0

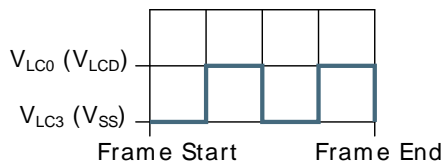

29.3.3.2 Waveforms with 1/2 Bias and Duplex Multiplexing

In this mode, each frame is divided into 4 periods. LCD_COM[1:0] lines can be multiplexed with all segment lines. Figures show 1/2 bias and duplex multiplexing (waveforms show two frames)

Figure 29.5. LCD 1/2 Bias and Duplex Multiplexing - LCD_COM0

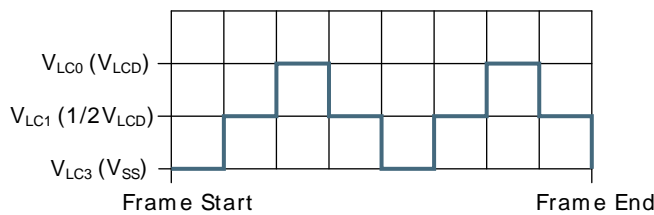
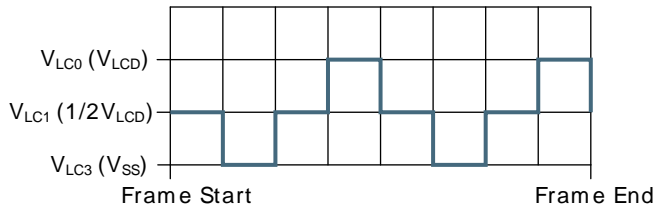

Figure 29.6. LCD 1/2 Bias and Duplex Multiplexing - LCD_COM1



1/2 bias and duplex multiplexing - LCD_SEG0

The LCD_SEG0 waveform on the left is just an example to illustrate how different segment waveforms can be multiplexed with the LCD_COM lines in order to turn on and off LCD pixels. As illustrated in the figures below, this waveform will turn ON pixels connected to LCD_COM0, while pixels connected to LCD_COM1 will be turned OFF.

Figure 29.7. LCD 1/2 Bias and Duplex Multiplexing - LCD_SEG0

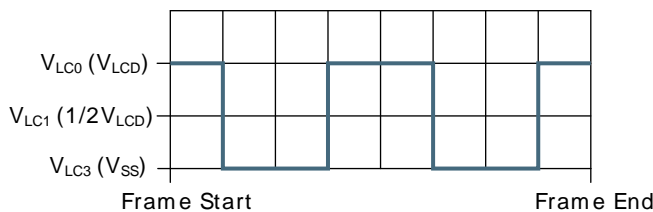
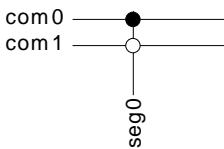

Figure 29.8. LCD 1/2 Bias and Duplex Multiplexing - LCD_SEG0 Connection



1/2 bias and duplex multiplexing - LCD_SEG0-LCD_COM0

- DC voltage = 0 (over one frame)
- $V_{RMS} = 0.79 \times V_{LCD_OUT}$
- The LCD display pixel that is connected to LCD_SEG0 and LCD_COM0 will be ON with this waveform.

Figure 29.9. LCD 1/2 Bias and Duplex Multiplexing - LCD_SEG0-LCD_COM0

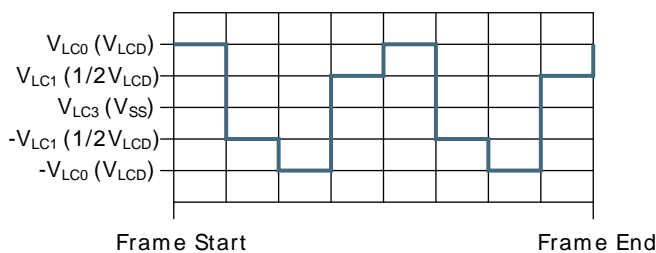

1/2 bias and duplex multiplexing - LCD_SEG0-LCD_COM1

- DC voltage = 0 (over one frame)
- $V_{RMS} = 0.35 \times V_{LCD_OUT}$
- The LCD display pixel that is connected to LCD_SEG0 and LCD_COM0 will be OFF with this waveform

Figure 29.10. LCD 1/2 Bias and Duplex Multiplexing - LCD_SEG0-LCD_COM1

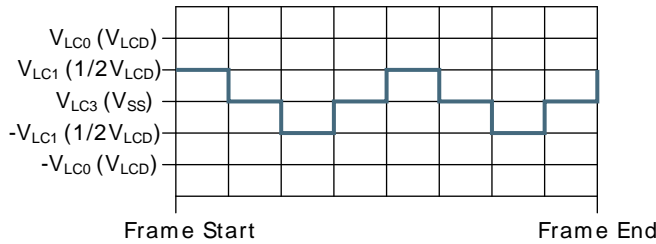

29.3.3.3 Waveforms with 1/3 Bias and Duplex Multiplexing

In this mode, each frame is divided into 4 periods. LCD_COM[1:0] lines can be multiplexed with all segment lines. Figures show 1/3 bias and duplex multiplexing (waveforms show two frames).

Figure 29.11. LCD 1/3 Bias and Duplex Multiplexing - LCD_COM0

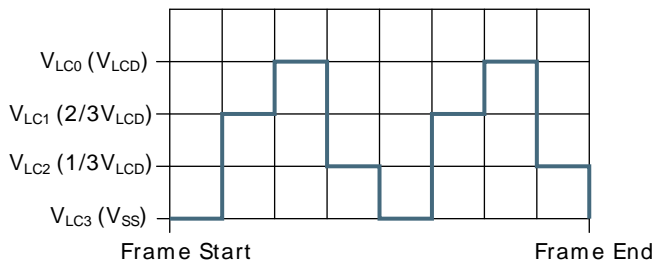
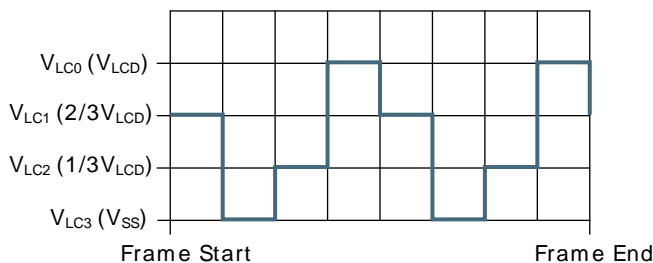

Figure 29.12. LCD 1/3 Bias and Duplex Multiplexing - LCD_COM1



1/3 bias and duplex multiplexing - LCD_SEG0

The LCD_SEG0 waveform on the left is just an example to illustrate how different segment waveforms can be multiplexed with the COM lines in order to turn on and off LCD pixels. As illustrated in the figures below, this waveform will turn ON pixels connected to LCD_COM0, while pixels connected to LCD_COM1 will be turned OFF.

Figure 29.13. LCD 1/3 Bias and Duplex Multiplexing - LCD_SEG0

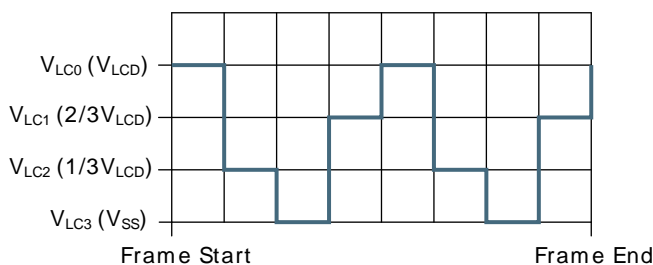
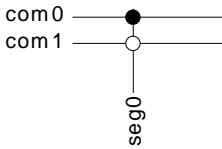

Figure 29.14. LCD 1/3 Bias and Duplex Multiplexing - LCD_SEG0 Connection



1/3 bias and duplex multiplexing - LCD_SEG0-LCD_COM0

- DC voltage = 0 (over one frame)
- $V_{RMS} = 0.75 \times V_{LCD_OUT}$
- The LCD display pixel that is connected to LCD_SEG0 and LCD_COM0 will be ON with this waveform

Figure 29.15. LCD 1/3 Bias and Duplex Multiplexing - LCD_SEG0-LCD_COM0

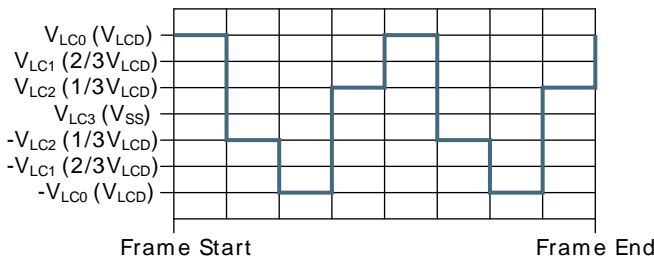

1/3 bias and duplex multiplexing - LCD_SEG0-LCD_COM0

- DC voltage = 0 (over one frame)
- $V_{RMS} = 0.33 \times V_{LCD_OUT}$
- The LCD display pixel that is connected to LCD_SEG0 and LCD_COM1 will be OFF with this waveform

Figure 29.16. LCD 1/3 Bias and Duplex Multiplexing - LCD_SEG0-LCD_COM1

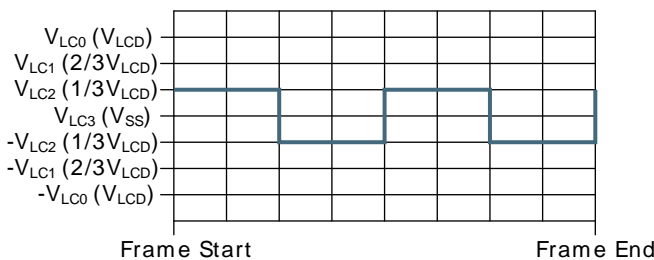

29.3.3.4 Waveforms with 1/2 Bias and Triplex Multiplexing

In this mode, each frame is divided into 6 periods. LCD_COM[2:0] lines can be multiplexed with all segment lines. Figures show 1/2 bias and triplex multiplexing (waveforms show two frames).

Figure 29.17. LCD 1/2 Bias and Triplex Multiplexing - LCD_COM0

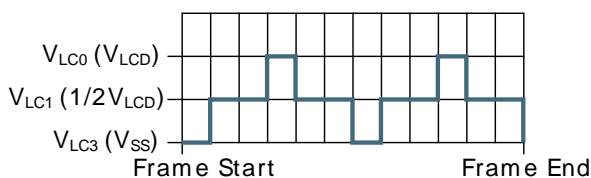

Figure 29.18. LCD 1/2 Bias and Triplex Multiplexing - LCD_COM1

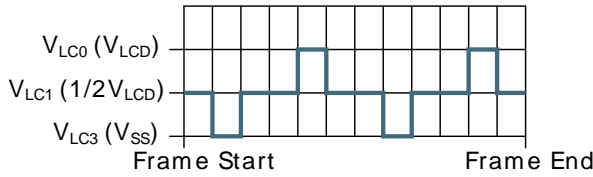
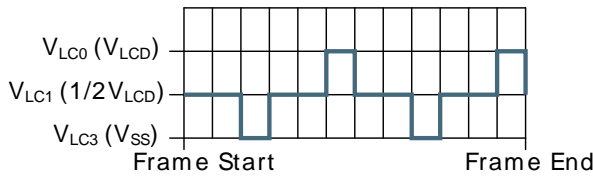

Figure 29.19. LCD 1/2 Bias and Triplex Multiplexing - LCD_COM2



1/2 bias and triplex multiplexing - LCD_SEG0

The LCD_SEG0 waveform on the left is just an example to illustrate how different segment waveforms can be multiplexed with the COM lines in order to turn on and off LCD pixels. As illustrated in the figures below, this waveform will turn ON pixels connected to LCD_COM1, while pixels connected to LCD_COM0 and LCD_COM2 will be turned OFF.

Figure 29.20. LCD 1/2 Bias and Triplex Multiplexing - LCD_SEG0

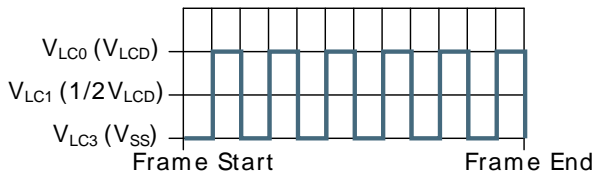
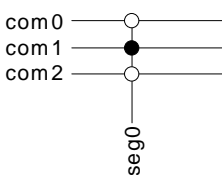

Figure 29.21. LCD 1/2 Bias and Triplex Multiplexing - LCD_SEG0 Connection



1/2 bias and triplex multiplexing - LCD_SEG0-LCD_COM0

- DC voltage = 0 (over one frame)
- $V_{RMS} = 0.4 \times V_{LCD_OUT}$
- The LCD display pixel that is connected to LCD_SEG0 and LCD_COM0 will be OFF with this waveform

Figure 29.22. LCD 1/2 Bias and Triplex Multiplexing - LCD_SEG0-LCD_COM0

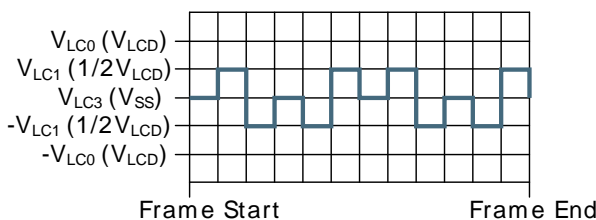

1/2 bias and triplex multiplexing - LCD_SEG0-LCD_COM1

- DC voltage = 0 (over one frame)
- $V_{RMS} = 0.7 V_{LCD_OUT}$
- The LCD display pixel that is connected to LCD_SEG0 and LCD_COM1 will be ON with this waveform

Figure 29.23. LCD 1/2 Bias and Triplex Multiplexing - LCD_SEG0-LCD_COM1

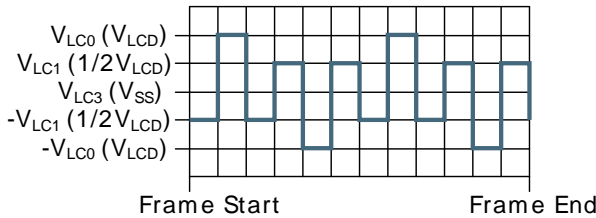

1/2 bias and triplex multiplexing - LCD_SEG0-LCD_COM2

- DC voltage = 0 (over one frame)
- $V_{RMS} = 0.4 \times V_{LCD_OUT}$
- The LCD display pixel that is connected to LCD_SEG0 and LCD_COM2 will be OFF with this waveform

Figure 29.24. LCD 1/2 Bias and Triplex Multiplexing - LCD_SEG0-LCD_COM2

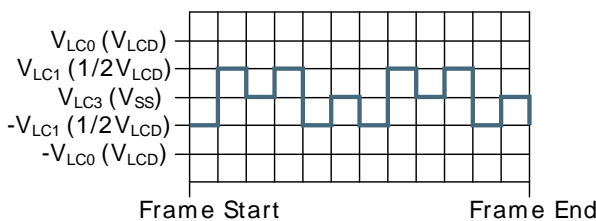

29.3.3.5 Waveforms with 1/3 Bias and Triplex Multiplexing

In this mode, each frame is divided into 6 periods. LCD_COM[2:0] lines can be multiplexed with all segment lines. Figures show 1/3 bias and triplex multiplexing (waveforms show two frames).

Figure 29.25. LCD 1/3 Bias and Triplex Multiplexing - LCD_COM0

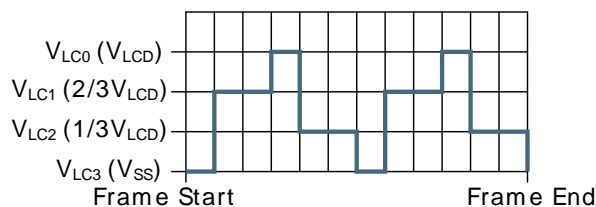

Figure 29.26. LCD 1/3 Bias and Triplex Multiplexing - LCD_COM1

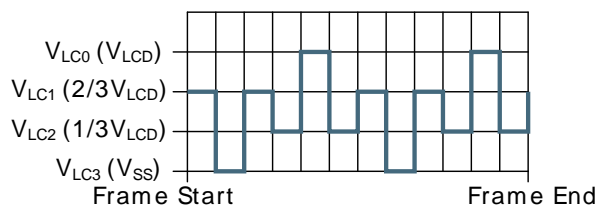
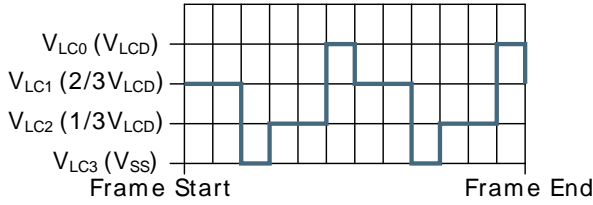

Figure 29.27. LCD 1/3 Bias and Triplex Multiplexing - LCD_COM2



1/3 bias and triplex multiplexing - LCD_SEG0

The LCD_SEG0 waveform illustrates how different segment waveforms can be multiplexed with the COM lines in order to turn on and off LCD pixels. As illustrated in the figures below, this waveform will turn ON pixels connected to LCD_COM1, while pixels connected to LCD_COM0 and LCD_COM2 will be turned OFF.

Figure 29.28. LCD 1/3 Bias and Triplex Multiplexing - LCD_SEG0

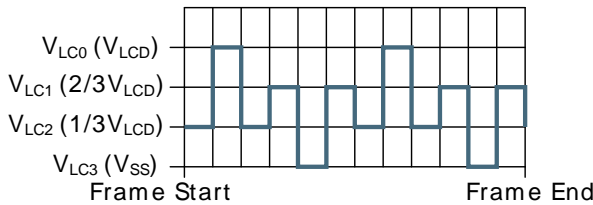
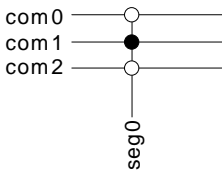

Figure 29.29. LCD 1/3 Bias and Triplex Multiplexing - LCD_SEG0 Connection



1/3 bias and triplex multiplexing - LCD_SEG0-LCD_COM0

- DC voltage = 0 (over one frame)
- $V_{RMS} = 0.33 V_{LCD_OUT}$
- The LCD display pixel that is connected to LCD_SEG0 and LCD_COM0 will be OFF with this waveform

Figure 29.30. LCD 1/3 Bias and Triplex Multiplexing - LCD_SEG0-LCD_COM0

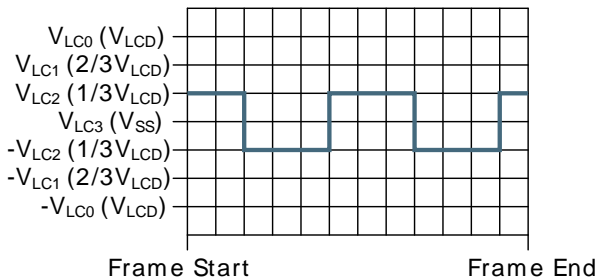

1/3 bias and triplex multiplexing - LCD_SEG0-LCD_COM1

- DC voltage = 0 (over one frame)
- $V_{RMS} = 0.64 \times V_{LCD_OUT}$

- The LCD display pixel that is connected to LCD_SEG0 and LCD_COM1 will be ON with this waveform

Figure 29.31. LCD 1/3 Bias and Triplex Multiplexing - LCD_SEG0-LCD_COM1

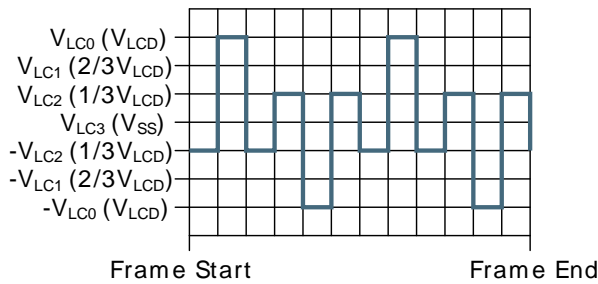

1/3 bias and triplex multiplexing - LCD_SEG0-LCD_COM2

- DC voltage = 0 (over one frame)
- $V_{RMS} = 0.33 \times V_{LCD_OUT}$
- The LCD display pixel that is connected to LCD_SEG0 and LCD_COM2 will be OFF with this waveform

Figure 29.32. LCD 1/3 Bias and Triplex Multiplexing - LCD_SEG0-LCD_COM2

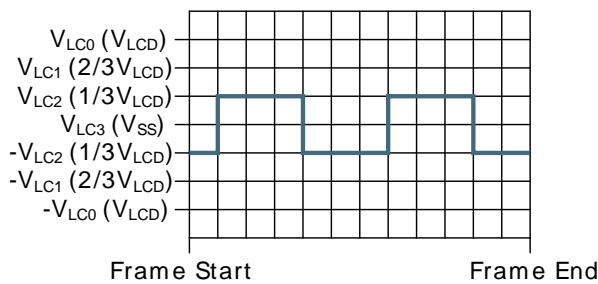

29.3.3.6 Waveforms with 1/3 Bias and Quadruplex Multiplexing

In this mode, each frame is divided into 8 periods. All COM lines can be multiplexed with all segment lines. Figures show 1/3 bias and quadruplex multiplexing (waveforms show two frames).

Figure 29.33. LCD 1/3 Bias and Quadruplex Multiplexing - LCD_COM0

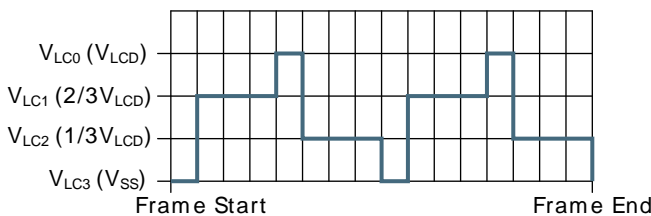

Figure 29.34. LCD 1/3 Bias and Quadruplex Multiplexing - LCD_COM1

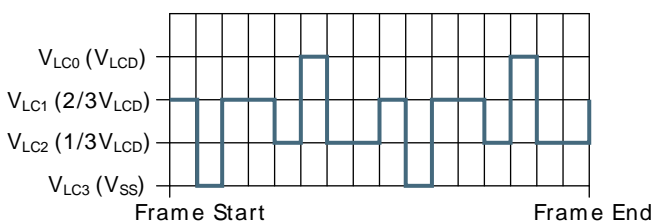

Figure 29.35. LCD 1/3 Bias and Quadruplex Multiplexing - LCD_COM2

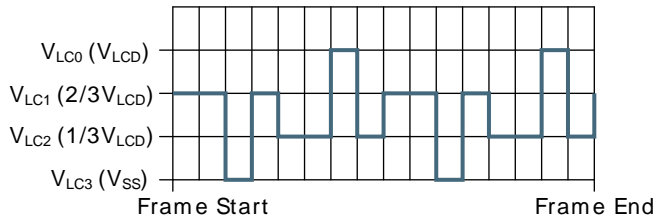
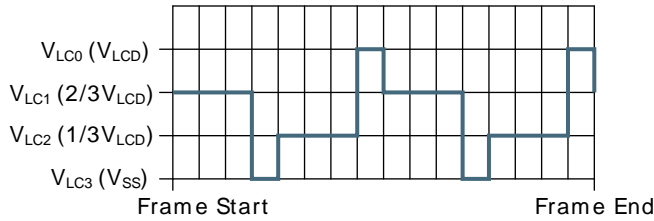

Figure 29.36. LCD 1/3 Bias and Quadruplex Multiplexing - LCD_COM3



1/3 bias and quadruplex multiplexing - LCD_SEG0

The LCD_SEG0 waveform on the left is just an example to illustrate how different segment waveforms can be multiplexed with the COM lines in order to turn on and off LCD pixels. As illustrated in the figures below, this wave form will turn ON pixels connected to LCD_COM0 and LCD_COM2, while pixels connected to LCD_COM1 and LCD_COM3 will be turned OFF.

Figure 29.37. LCD 1/3 Bias and Quadruplex Multiplexing - LCD_SEG0

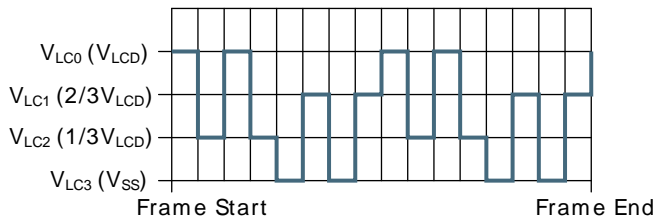
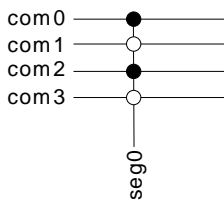

Figure 29.38. LCD 1/3 Bias and Quadruplex Multiplexing - LCD_SEG0 Connection



1/3 bias and quadruplex multiplexing - LCD_SEG0-LCD_COM0

- DC voltage = 0 (over one frame)
- $V_{RMS} = 0.58 \times V_{LCD_OUT}$
- The LCD display pixel that is connected to LCD_SEG0 and LCD_COM0 will be ON with this waveform

Figure 29.39. LCD 1/3 Bias and Quadruplex Multiplexing - LCD_SEG0-LCD_COM0

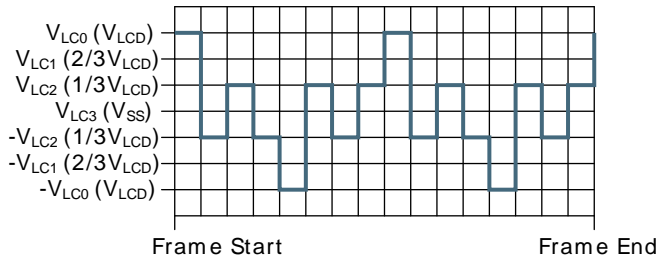

1/3 bias and quadruplex multiplexing - LCD_SEG0-LCD_COM1

- DC voltage = 0 (over one frame)
- $V_{RMS} = 0.33 \times V_{LCD_OUT}$
- The LCD display pixel that is connected to LCD_SEG0 and LCD_COM1 will be OFF with this waveform

Figure 29.40. LCD 1/3 Bias and Quadruplex Multiplexing - LCD_SEG0-LCD_COM1

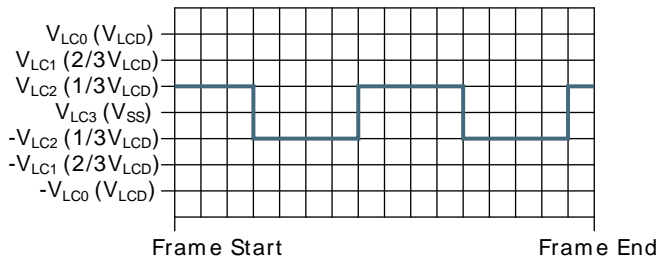

1/3 bias and quadruplex multiplexing - LCD_SEG0-LCD_COM2

- DC voltage = 0 (over one frame)
- $V_{RMS} = 0.58 \times V_{LCD_OUT}$
- The LCD display pixel that is connected to LCD_SEG0 and LCD_COM2 will be ON with this waveform

Figure 29.41. LCD 1/3 Bias and Quadruplex Multiplexing - LCD_SEG0-LCD_COM2

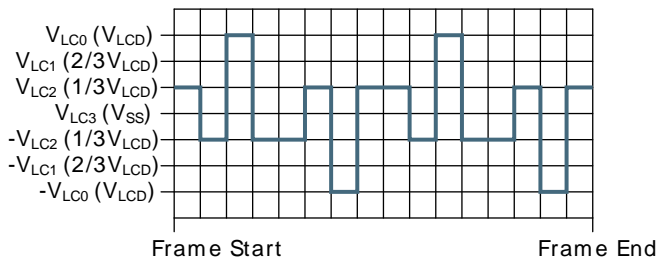

1/3 bias and quadruplex multiplexing - LCD_SEG0-LCD_COM2

- DC voltage = 0 (over one frame)
- $V_{RMS} = 0.33 \times V_{LCD_OUT}$
- The LCD display pixel that is connected to LCD_SEG0 and LCD_COM3 will be OFF with this waveform

Figure 29.42. LCD 1/3 Bias and Quadruplex Multiplexing- LCD_SEG0-LCD_COM3

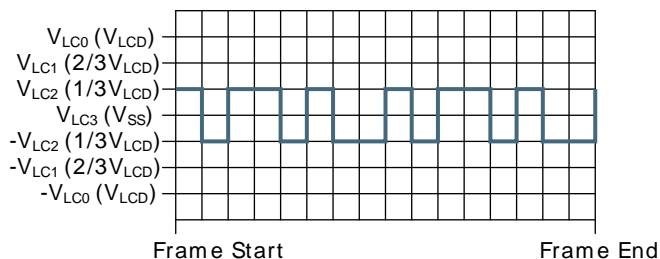

29.3.4 LCD Contrast

Different LCD panels have different characteristics and also temperature may affect the characteristics of the LCD panels. To compensate for such variations, the LCD driver has a programmable contrast that adjusts the V_{LCD_OUT} . The contrast is set by CONLEV in LCD_DISPCTRL, and can be adjusted relative to either V_{DD} (V_{LCD}) or Ground using CONCONF in LCD_DISPCTRL. See Table 29.4 (p. 427) and Table 29.5 (p. 427) , Table 29.5 (p. 427) and Table 29.6 (p. 428) .

Table 29.4. LCD Contrast

BIAS	CONLEV	Equation	Range
00	00000-11111	$V_{LCD_OUT} = V_{LCD} \times (0.61 \times (1 + CONLEV/(2^5 - 1)))$	CONLEV = 0 => $V_{LCD_OUT} = 0.61V_{LCD}$ CONLEV = 31 => $V_{LCD_OUT} = V_{LCD}$
01	00000-11111	$V_{LCD_OUT} = V_{LCD} \times (0.53 \times (1 + CONLEV/(2^5 - 1)))$	CONLEV = 0 => $V_{LCD_OUT} = 0.53V_{LCD}$ CONLEV = 31 => $V_{LCD_OUT} = V_{LCD}$
10	00000-11111	$V_{LCD_OUT} = V_{LCD} \times (0.61 \times (1 + CONLEV/(2^5 - 1)))$	CONLEV = 0 => $V_{LCD_OUT} = 0.61V_{LCD}$ CONLEV = 31 => $V_{LCD_OUT} = V_{LCD}$

Note

Reset value is maximum contrast

Table 29.5. LCD Contrast Function

CONCONF	Function
0	Contrast is adjusted relative to V_{DD} (V_{LCD})
1	Contrast is adjusted relative to Ground

Table 29.6. LCD Principle of Contrast Adjustment for Different Bias Settings.

	Contrast adjustment relative to V _{DD} (V _{LCD}) (CONCONF = 0)	Contrast adjustment relative to GND (CONCONF = 1)	No contrast adjustment (CONLEV = 11111)
1/3 bias			
1/2 bias			
Static			

R0 = R1 = R2 in the figure, while Rx is adjusted by changing the CONLEV bits.

29.3.5 V_{LCD} Selection

By default, the LCD driver runs on main external power (V_{LCD} = V_{DD}), see Table 29.7 (p. 428) . An internal boost circuit can be enabled by setting VBOOSTEN in CMU_LCDCTRL and selecting the boosted voltage by setting VLCDSEL in LCD_DISPCTRL. This will boost V_{LCD} to V_{BOOST}. V_{BOOST} can be selected in the range of 3.0 V – 3.6 V by configuring VBLEV in LCD_DISPCTRL. Note that the boost circuit is not designed to operate with the selected boost voltage, V_{BOOST}, smaller than V_{DD}. The boost circuit can boost the V_{LCD} up to 3.6 V when V_{DD} is as low as 2.0 V.

When using the voltage booster, the LCD_BEXT pin must be connected through a 1 μF capacitor to VSS, and the LCD_BCAP_P and LCD_BCAP_N pins must be connected to each other through a 22 nF capacitor.

It is also possible to connect a dedicated power supply to the LCD module. The LCD external power supply must be connected to the LCD_BEXT pin and VLCDSEL in LCD_DISPCTRL must be set. In this mode, the voltage booster should be disabled.

Table 29.7. LCD V_{LCD}

VLCDSEL	Mode	V _{LCD}
0	VDD	V _{DD} (same as main external power)
1	VBOOST	Voltage booster/External V _{DD}

29.3.6 VBOOST Control

The boost voltage is configurable. By programming the VBLEV bits in LCD_DISPCTRL, the boost voltage level can be adjusted between 3.0V and 3.6V.

The boost circuit will use an update frequency given by the VBFREQ bits in CMU_LCDCTRL, see Table 29.8 (p. 429). It is possible to adjust the frequency to optimize performance for all kinds of LCD panels (large capacitors may require less frequent updates, while small capacitors may require more frequent updates). A lower update frequency would in general lead to smaller current consumption.

Table 29.8. LCD V_{BOOST} Frequency

VBFREQ	V _{BOOST} Update Frequency
000	LFACLK
001	LFACLK/2
010	LFACLK/4
011	LFACLK/8
100	LFACLK/16
101	LFACLK/32
110	LFACLK/64
111	LFACLK/128

29.3.7 Framerate

It is important to choose the correct framerate for the LCD display. Normally, the framerate should be between 30 and 100 Hz. A framerate below 30 Hz may lead to flickering, while a framerate above 100 Hz may lead to ghosting and unnecessarily high power consumption.

29.3.7.1 Clock Selection and Prescaler

The LFACLK is prescaled to LFACLK_{LCDpre} in the CMU. The available prescaler settings are:

- LFCLK16: LFACLK_{LCDpre} = LFACLK/16
- LFCLK32: LFACLK_{LCDpre} = LFACLK/32
- LFCLK64: LFACLK_{LCDpre} = LFACLK/64
- LFCLK128: LFACLK_{LCDpre} = LFACLK/128

In addition to selecting the correct prescaling, the clock source can be selected in the CMU.

To use this module, the LE interface clock must be enabled in CMU_HFCORECLKEN0, in addition to the module clock.

29.3.7.2 Framerate Division Register

The framerate is set in the CMU by programming the framerate division bits FDIV in CMU_LCDCTRL. This setting should not be changed while the LCD driver is running. The equation for calculating the resulting framerate is given from Equation 29.1 (p. 429)

LCD Framerate Calculation

$$\text{LFACLK}_{\text{LCD}} = \text{LFACLK}_{\text{LCDpre}} / (1 + \text{FDIV}) \quad (29.1)$$

Table 29.9. LCD Framerate Conversion Table

MUX Mode	Frame- rate formula	Resulting Framerate, CLK _{FRAME} (Hz)							
		LFACLK _{LCDpre} = 2 kHz		LFACLK _{LCDpre} = 1 kHz		LFACLK _{LCDpre} = 0.5 kHz		LFACLK _{LCDpre} = 0.25 kHz	
		Min	Max	Min	Max	Min	Max	Min	Max
Static	LFACLK _{LCD} /2	128	1024	64	512	32	256	16	128
Duplex	LFACLK _{LCD} /4	64	512	32	256	16	128	8	64
Triplex	LFACLK _{LCD} /6	43	341	21	171	11	85	5	43
Quadruplex	LFACLK _{LCD} /8	32	256	16	128	8	64	4	32

Table settings: Min: FDIV = 7, Max: FDIV = 0

29.3.8 Data Update

The LCD Driver logic that controls the output waveforms is clocked on LFACLK_{LCDpre}. The LCD data and Control Registers are clocked on the HFCORECLK. To avoid metastability and unpredictable behavior, the data in the Segment Data (SEGDn) registers must be synchronized to the LCD driver logic. Also, it is important that data is updated at the beginning of an LCD frame since the segment waveform depends on the segment data and a change in the middle of a frame may lead to a DC-component in that frame. The LCD driver has dedicated functionality to synchronize data transfer to the LCD frames. The synchronization logic is applied to all data that need to be updated at the beginning of the LCD frames:

- LCD_SEGDn
- LCD_AREGA
- LCD_AREGB
- LCD_BACTRL

The different methods to update data are controlled by the UDCTRL bits in LCD_CTRL.

Table 29.10. LCD Update Data Control (UDCTRL) Bits

UDCTRL	Mode	Description
00	REGULAR	The data transfer is controlled by SW and data synchronization is initiated by writing data to the buffers. Data is transferred as soon as possible, possibly creating a frame with a DC component on the LCD.
01	FCEVENT	The data transfer is done at the next event triggered by the Frame Counter (FC). See Section 29.3.9 (p. 430) for details on how to configure the Frame Counter. Optionally, the Frame Counter can also generate an interrupt at every event.
10	FRAMESTART	The data transfer is done at frame-start.

29.3.9 Frame Counter (FC)

The Frame Counter is synchronized to the LCD frame start and will generate an event after a programmable number of frames. An FC event can trigger:

- LCD ready interrupt
- Blink (controlling the blink frequency)
- Next state in the Animation State Machine
- Data update if UDCTRL = 01

The Frame Counter is a down counter. It is enabled by writing FCEN in LCD_BACTRL. Optionally, the Frame Counter can be prescaled so that the Frame Counter is decremented at:

- Every frame
- Every second frame
- Every fourth frame
- Every eighth frame

This is controlled by the FCPRESC in LCD_BACTRL, see Table 29.11 (p. 431)

Table 29.11. FCPRESC

FCPRESC	Mode	Description	General equation
00	Div1	CLK _{FRAME} /1	$CLK_{FC} = CLK_{FRAME} / 2^{FCPRESC}$
01	Div2	CLK _{FRAME} /2	
10	Div4	CLK _{FRAME} /4	
11	Div8	CLK _{FRAME} /8	

The top value for the Frame Counter is set by FCTOP in LCD_BACTRL. Every time the frame counter reaches zero, it is reloaded with the top value, and at the same time an event, which can cause an interrupt, data update, blink, or an animation state transition is triggered.

LCD Event Frequency Equation

$$CLK_{EVENT} = CLK_{FC} / (1 + FCTOP[5:0]) \text{ Hz} \tag{29.2}$$

The above equation shows how to set-up the LCD event frequency. In this example, the framerate is 64Hz, and the LCD event frequency should be set-up to 2 seconds.

Example 29.1. LCD Event Frequency Example

- Write FCPRESC to 3 => CLK_{FC} = 8Hz (0.125 seconds)
- Write FCTOP to 15 => CLK_{EVENT} = 0.5Hz (2 seconds)

If higher resolution is required, configure a lower prescaler value and increase the FCPRESC in LCD_BACTRL accordingly (e.g. FCPRESC = 2, FCTOP = 31).

Figure 29.43. LCD Clock System in LCD Driver

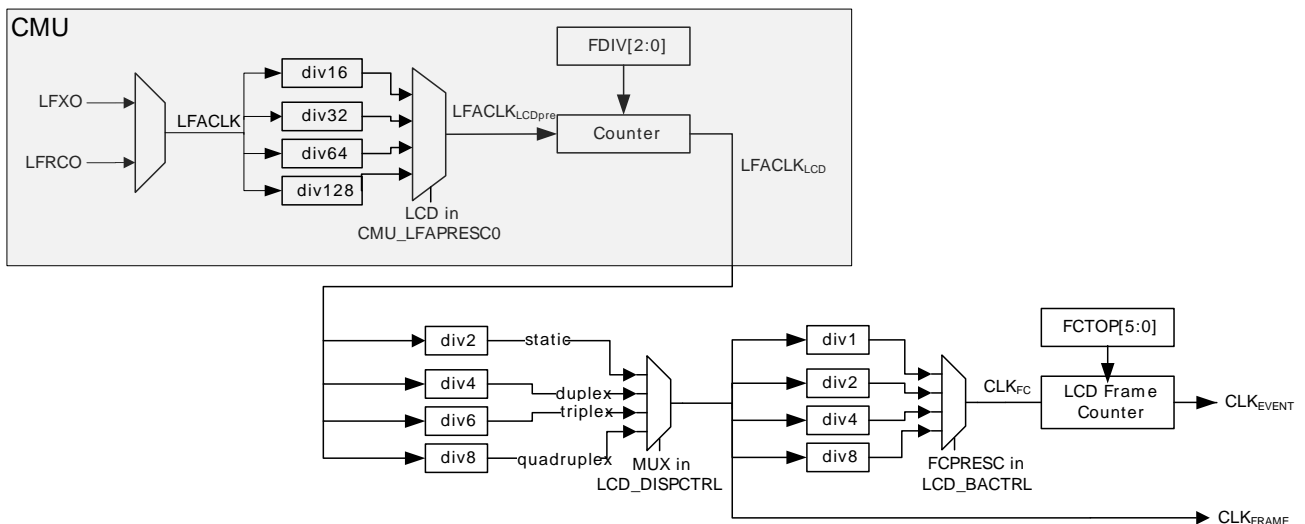

29.3.10 LCD Interrupt

The LCD interrupt can be used to synchronize data update. The FC interrupt flag is set at every LCD Frame Counter Event, which must be set-up separately. The interrupt is enabled by setting FC bit in LCD_IEN.

29.3.11 Blink, Blank, and Animation Features

29.3.11.1 Blink

The LCD driver can be configured to blink, alternating all enabled segments between on and off. The blink frequency is given by the CLK_{EVENT} frequency, see Section 29.3.9 (p. 430) . See Section 29.3.8 (p. 430) for details regarding synchronization of the blink feature. The FC must be on for blink to work.

29.3.11.2 Blank

Setting BLANK in LCD_BACTRL will output the “OFF” waveform on all enabled segments, effectively blanking the entire display. Writing the BLANK bit to zero disables the blanking and segment data will be output as normal. See Section 29.3.8 (p. 430) for details regarding synchronization of blank.

29.3.11.3 Animation State Machine

The Animation State Machine makes it possible to enable different animations without updating the data registers, allowing specialized patterns running on the LCD panel while the microcontroller remains in Low Energy Mode and thus saving power consumption. The animation feature is available on segment 0 to 7 multiplexed with LCD_COM0. The animation is implemented as two programmable 8 bits registers that are shifted left or right every other Animation state for a total of 16 states.

The shift operations applied to the shift registers are controlled by AREGASC and AREGBSC in LCD_BACTRL as shown in the table below. Note also that the FC must be on for animation to work, as it is the FC event that drives the animation state machine.

Table 29.12. LCD Animation Shift Register

AREG _n SC, n = A or B	Mode	Description
00	NOSHIFT	No Shift operation
01	SHIFLEFT	Animation register is shifted left (LCD_AREGA is shifted every odd state, LCD_AREGB is shifted every even state)
10	SHIFTRIGHT	Animation register is shifted right (LCD_AREGA is shifted every odd state, LCD_AREGB is shifted every even state)
11	Reserved	Reserved

The two registers are either OR'ed or AND'ed to achieve the displayed animation pattern. This is controlled by ALOGSEL in LCD_BACTRL as shown in Table 29.13 (p. 432) . In addition, the regular segment data SEG0[7:0] is OR'ed with the animation pattern to generate the resulting output.

Table 29.13. LCD Animation Pattern

ALOGSEL	Mode	Description
0	AND	LCD_AREGA and LCD_AREGB are AND'ed together
1	OR	LCD_AREGA and LCD_AREGB are OR'ed together

Each state is displayed one CLK_{EVENT} period, see Section 29.3.9 (p. 430) . By reading ASTATE in LCD_STATUS, software can identify which state that is currently active in the state sequence. Note that

the shifting operation is performed on internal registers that are not accessible in SW (when reading LCD_AREGA and LCD_AREGB, the data that was original written will also be read back). The SW must utilize the knowledge about the current state (ASTATE) to calculate what is currently output. ASTATE is cleared when LCD_AREGA or LCD_AREGB are updated with new values. See Table 29.14 (p. 433) for an example.

Table 29.14. LCD Animation Example

ASTATE	LCD_AREGA	LCD_AREGB	Resulting Data
0	11000000	11000000	11000000
1	01100000	11000000	11100000
2	01100000	01100000	01100000
3	00110000	01100000	01110000
4	00110000	00110000	00110000
5	00011000	00110000	00111000
6	00011000	00011000	00011000
7	00001100	00011000	00011100
8	00001100	00001100	00001100
9	00000110	00001100	00001110
10	00000110	00000110	00000110
11	00000011	00000110	00000111
12	00000011	00000011	00000011
13	10000001	00000011	10000011
14	10000001	10000001	10000001
15	11000000	10000001	11000001

In the table, AREGASC = 10, AREGASC = 10, ALOGSEL = 1 and the resulting data is be displayed on segment lines 7-0 multiplexed with LCD_COM0.

Figure 29.44. LCD Block Diagram of the Animation Circuit

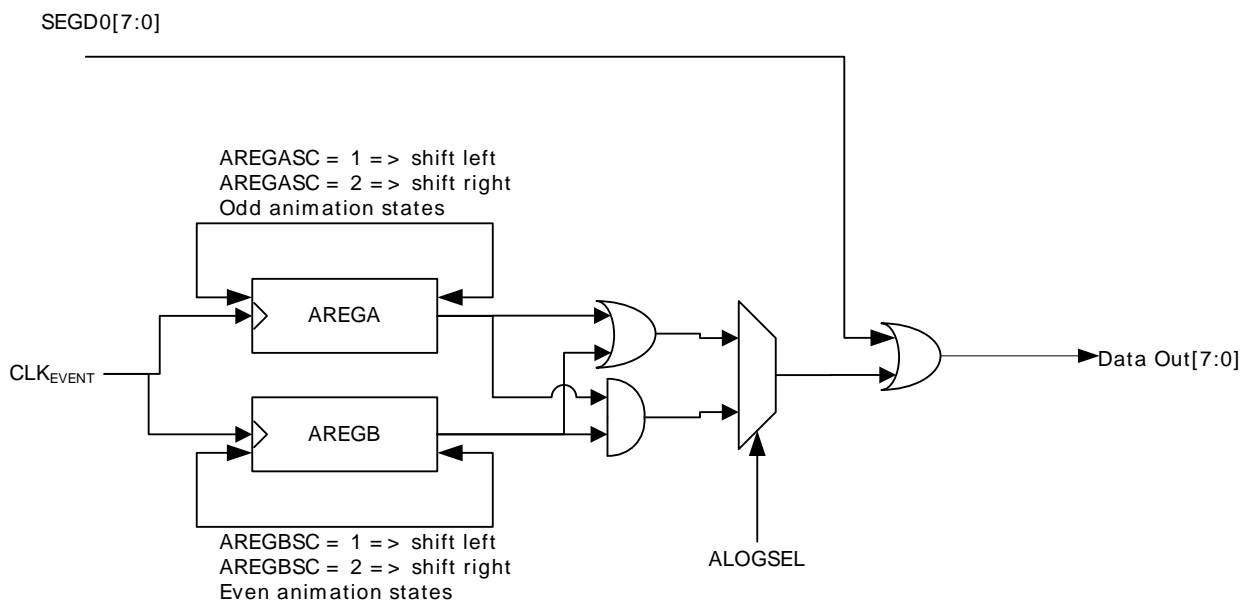

Example 29.2. LCD Animation Enable Example

- Write data into the animation registers LCD_AREGA, LCD_AREGB
- Enable the correct shift direction (if any)
- Decide which logical function to perform on the registers
 - ALOGSEL = 0: Data_out = LCD_AREGA & LCD_AREGB
 - ALOGSEL = 1: Data_out = LCD_AREGA | LCD_AREGB
- Configure the right animation period (CLK_{EVENT})
- Enable the animation pattern and frame counter (AEN = 1, FCEN = 1)

For updating data in the LCD while it is running an animation, and the new animation data depends on the pattern visible on the LCD, see the following example.

Example 29.3. LCD Animation Dependence Example

- Enable the LCD interrupt (the interrupt will be triggered simultaneously as the Animation State machine changes state)
- In the interrupt handler, read back the current state (ASTATE)
- Knowing the current state of the Animation State Machine makes it possible to calculate what data that is currently output
- Modify data as required (Data will be updated at the next Frame Counter Event). It is important that new data is written before the next Frame Counter Event.

29.3.12 LCD in Low Energy Modes

As long as the LFACTLK is running (EM0-EM2), the LCD controller continues to output LCD waveforms according to the data that is currently synchronized to the LCD Driver logic. In addition, the following features are still active if enabled:

- Animation State Machine
- Blink
- LCD Event Interrupt

29.3.13 Register access

Since this module is a Low Energy Peripheral, and runs off a clock which is asynchronous to the HFCORECLK, special considerations must be taken when accessing registers. Please refer to Section 5.3 (p. 18) for a description on how to perform register accesses to Low Energy Peripherals.

29.4 Register Map

The offset register address is relative to the registers base address.

Offset	Name	Type	Description
0x000	LCD_CTRL	RW	Control Register
0x004	LCD_DISPCTRL	RW	Display Control Register
0x008	LCD_SEGEN	RW	Segment Enable Register
0x00C	LCD_BACTRL	RW	Blink and Animation Control Register
0x010	LCD_STATUS	R	Status Register
0x014	LCD_AREGA	RW	Animation Register A
0x018	LCD_AREGB	RW	Animation Register B
0x01C	LCD_IF	R	Interrupt Flag Register
0x020	LCD_IFS	W1	Interrupt Flag Set Register
0x024	LCD_IFC	W1	Interrupt Flag Clear Register
0x028	LCD_IEN	RW	Interrupt Enable Register
0x040	LCD_SEGD0L	RW	Segment Data Low Register 0
0x044	LCD_SEGD1L	RW	Segment Data Low Register 1
0x048	LCD_SEGD2L	RW	Segment Data Low Register 2
0x04C	LCD_SEGD3L	RW	Segment Data Low Register 3
0x050	LCD_SEGD0H	RW	Segment Data High Register 0
0x054	LCD_SEGD1H	RW	Segment Data High Register 1
0x058	LCD_SEGD2H	RW	Segment Data High Register 2
0x05C	LCD_SEGD3H	RW	Segment Data High Register 3
0x060	LCD_FREEZE	RW	Freeze Register
0x064	LCD_SYNCBUSY	R	Synchronization Busy Register

29.5 Register Description

29.5.1 LCD_CTRL - Control Register (Async Reg)

For more information about Asynchronous Registers please see Section 5.3 (p. 18) .

Offset	Bit Position																															
	31	30	29	28	27	26	25	24	23	22	21	20	19	18	17	16	15	14	13	12	11	10	9	8	7	6	5	4	3	2	1	0
0x000																																
Reset																																
Access																																
Name																																
																															UDCTRL	EN

Bit	Name	Reset	Access	Description
31:3	Reserved			To ensure compatibility with future devices, always write bits to 0. More information in Section 2.1 (p. 3)
2:1	UDCTRL	0x0	RW	Update Data Control

These bits control how data from the SEGDN registers are transferred to the LCD driver.

Value	Mode	Description
0	REGULAR	The data transfer is controlled by SW. Transfer is performed as soon as possible
1	FCEVENT	The data transfer is done at the next event triggered by the Frame Counter

Bit	Name	Reset	Access	Description
	Value	Mode		Description
2	FRAMESTART			The data transfer is done continuously at every LCD frame start

0 EN 0 RW **LCD Enable**

When this bit is set, the LCD driver is enabled and the driver will start outputting waveforms on the com/segment lines.

29.5.2 LCD_DISPCTRL - Display Control Register

Offset	Bit Position																																									
0x004	31	30	29	28	27	26	25	24	23	22	21	20	19	18	17	16	15	14	13	12	11	10	9	8	7	6	5	4	3	2	1	0										
Reset													0x3				0		0														0x1F				0		0x0		0x0	
Access													RW				RW		RW														RW				RW		RW		RW	
Name													VBLEV				VLCDSEL		CONCONF														CONLEV				WAVE		BIAS		MUX	

Bit	Name	Reset	Access	Description
31:21	Reserved	To ensure compatibility with future devices, always write bits to 0. More information in Section 2.1 (p. 3)		

20:18 VBLEV 0x3 RW **Voltage Boost Level**

These bits control Voltage Boost level. Please refer to datasheet for further details of the boost levels.

Value	Mode	Description
0	LEVEL0	Minimum boost level
1	LEVEL1	
2	LEVEL2	
3	LEVEL3	
4	LEVEL4	
5	LEVEL5	
6	LEVEL6	
7	LEVEL7	Maximum boost level

17 Reserved To ensure compatibility with future devices, always write bits to 0. More information in Section 2.1 (p. 3)

16 VLCDSEL 0 RW **V_{LCD} Selection**

This bit controls which Voltage source that is connected to V_{LCD}.

Value	Mode	Description
0	VDD	VDD
1	VEXTBOOST	Voltage Booster/External VDD

15 CONCONF 0 RW **Contrast Configuration**

This bit selects whether the contrast adjustment is done relative to V_{LCD} or Ground.

Value	Mode	Description
0	VLCD	Contrast is adjusted relative to V _{LCD}
1	GND	Contrast is adjusted relative to Ground

14:13 Reserved To ensure compatibility with future devices, always write bits to 0. More information in Section 2.1 (p. 3)

12:8 CONLEV 0x1F RW **Contrast Level**

These bits control the contrast setting according to this formula: $V_{LCD_OUT} = V_{LCD} \times 0.5(1+CONLEV/31)$.

Value	Mode	Description
0	MIN	Minimum contrast
31	MAX	Maximum contrast

7:5 Reserved To ensure compatibility with future devices, always write bits to 0. More information in Section 2.1 (p. 3)

Bit	Name	Reset	Access	Description
4	WAVE	0	RW	Waveform Selection This bit configures the output waveform.
	Value	Mode	Description	
	0	LOWPOWER	Low power waveform	
	1	NORMAL	Normal waveform	
3:2	BIAS	0x0	RW	Bias Configuration These bits set the bias mode for the LCD Driver.
	Value	Mode	Description	
	0	STATIC	Static	
	1	ONEHALF	1/2 Bias	
	2	ONETHIRD	1/3 Bias	
1:0	MUX	0x0	RW	Mux Configuration These bits set the multiplexing mode for the LCD Driver.
	Value	Mode	Description	
	0	STATIC	Static	
	1	DUPLEX	Duplex	
	2	TRIPLEX	Triplex	
	3	QUADRUPLEX	Quadruplex	

29.5.3 LCD_SEGEN - Segment Enable Register

Offset	Bit Position																															
0x008	31	30	29	28	27	26	25	24	23	22	21	20	19	18	17	16	15	14	13	12	11	10	9	8	7	6	5	4	3	2	1	0
Reset																							0x000									
Access																							RW									
Name																							SEGEN									

Bit	Name	Reset	Access	Description
31:10	<i>Reserved</i>	<i>To ensure compatibility with future devices, always write bits to 0. More information in Section 2.1 (p. 3)</i>		
9:0	SEGEN	0x000	RW	Segment Enable Determines which segment lines are enabled. Each bit represents a group of 4 segment lines. To enable segment lines X to X+3, set bit X/4, i.e. to enable output on segment lines 4,5,6 and 7, set bit 1. Each LCD segment pin can also be individually disabled by setting the pin to any other state than DISABLED in the GPIO pin configuration. Note that this feature is not available on EFM32G revisions A and B.

29.5.4 LCD_BACTRL - Blink and Animation Control Register (Async Reg)

For more information about Asynchronous Registers please see Section 5.3 (p. 18) .

Offset	Bit Position																																							
	31	30	29	28	27	26	25	24	23	22	21	20	19	18	17	16	15	14	13	12	11	10	9	8	7	6	5	4	3	2	1	0								
0x00C																																								
Reset									0x00								0x0																0	0	0x0	0x0	0	0	0	0
Access									RW								RW																RW	RW	RW	RW	RW	RW	RW	RW
Name									FCTOP								FCPRESC																FCEN	ALOGSEL	AREGBSC	AREGASC	AEN	BLANK	BLINKEN	

Bit	Name	Reset	Access	Description															
31:24	Reserved	To ensure compatibility with future devices, always write bits to 0. More information in Section 2.1 (p. 3)																	
23:18	FCTOP	0x00	RW	Frame Counter Top Value These bits contain the Top Value for the Frame Counter: $CLK_{EVENT} = CLK_{FC} / (1 + FCTOP[5:0])$.															
17:16	FCPRESC	0x0	RW	Frame Counter Prescaler These bits controls the prescaling value for the Frame Counter input clock.															
				<table border="1"> <thead> <tr> <th>Value</th> <th>Mode</th> <th>Description</th> </tr> </thead> <tbody> <tr> <td>0</td> <td>DIV1</td> <td>$CLK_{FC} = CLK_{FRAME} / 1$</td> </tr> <tr> <td>1</td> <td>DIV2</td> <td>$CLK_{FC} = CLK_{FRAME} / 2$</td> </tr> <tr> <td>2</td> <td>DIV4</td> <td>$CLK_{FC} = CLK_{FRAME} / 4$</td> </tr> <tr> <td>3</td> <td>DIV8</td> <td>$CLK_{FC} = CLK_{FRAME} / 8$</td> </tr> </tbody> </table>	Value	Mode	Description	0	DIV1	$CLK_{FC} = CLK_{FRAME} / 1$	1	DIV2	$CLK_{FC} = CLK_{FRAME} / 2$	2	DIV4	$CLK_{FC} = CLK_{FRAME} / 4$	3	DIV8	$CLK_{FC} = CLK_{FRAME} / 8$
Value	Mode	Description																	
0	DIV1	$CLK_{FC} = CLK_{FRAME} / 1$																	
1	DIV2	$CLK_{FC} = CLK_{FRAME} / 2$																	
2	DIV4	$CLK_{FC} = CLK_{FRAME} / 4$																	
3	DIV8	$CLK_{FC} = CLK_{FRAME} / 8$																	
15:9	Reserved	To ensure compatibility with future devices, always write bits to 0. More information in Section 2.1 (p. 3)																	
8	FCEN	0	RW	Frame Counter Enable When this bit is set, the frame counter is enabled.															
7	ALOGSEL	0	RW	Animate Logic Function Select When this bit is set, the animation registers are AND'ed together. When this bit is cleared, the animation registers are OR'ed together.															
				<table border="1"> <thead> <tr> <th>Value</th> <th>Mode</th> <th>Description</th> </tr> </thead> <tbody> <tr> <td>0</td> <td>AND</td> <td>AREGA and AREGB AND'ed</td> </tr> <tr> <td>1</td> <td>OR</td> <td>AREGA and AREGB OR'ed</td> </tr> </tbody> </table>	Value	Mode	Description	0	AND	AREGA and AREGB AND'ed	1	OR	AREGA and AREGB OR'ed						
Value	Mode	Description																	
0	AND	AREGA and AREGB AND'ed																	
1	OR	AREGA and AREGB OR'ed																	
6:5	AREGBSC	0x0	RW	Animate Register B Shift Control These bits controls the shift operation that is performed on Animation register B.															
				<table border="1"> <thead> <tr> <th>Value</th> <th>Mode</th> <th>Description</th> </tr> </thead> <tbody> <tr> <td>0</td> <td>NOSHIFT</td> <td>No Shift operation on Animation Register B</td> </tr> <tr> <td>1</td> <td>SHIFLEFT</td> <td>Animation Register B is shifted left</td> </tr> <tr> <td>2</td> <td>SHIFRIGHT</td> <td>Animation Register B is shifted right</td> </tr> </tbody> </table>	Value	Mode	Description	0	NOSHIFT	No Shift operation on Animation Register B	1	SHIFLEFT	Animation Register B is shifted left	2	SHIFRIGHT	Animation Register B is shifted right			
Value	Mode	Description																	
0	NOSHIFT	No Shift operation on Animation Register B																	
1	SHIFLEFT	Animation Register B is shifted left																	
2	SHIFRIGHT	Animation Register B is shifted right																	
4:3	AREGASC	0x0	RW	Animate Register A Shift Control These bits controls the shift operation that is performed on Animation register A.															
				<table border="1"> <thead> <tr> <th>Value</th> <th>Mode</th> <th>Description</th> </tr> </thead> <tbody> <tr> <td>0</td> <td>NOSHIFT</td> <td>No Shift operation on Animation Register A</td> </tr> <tr> <td>1</td> <td>SHIFLEFT</td> <td>Animation Register A is shifted left</td> </tr> <tr> <td>2</td> <td>SHIFRIGHT</td> <td>Animation Register A is shifted right</td> </tr> </tbody> </table>	Value	Mode	Description	0	NOSHIFT	No Shift operation on Animation Register A	1	SHIFLEFT	Animation Register A is shifted left	2	SHIFRIGHT	Animation Register A is shifted right			
Value	Mode	Description																	
0	NOSHIFT	No Shift operation on Animation Register A																	
1	SHIFLEFT	Animation Register A is shifted left																	
2	SHIFRIGHT	Animation Register A is shifted right																	
2	AEN	0	RW	Animation Enable When this bit is set, the animate function is enabled.															
1	BLANK	0	RW	Blank Display When this bit is set, all segment output waveforms are configured to blank the LCD display. The Segment Data Registers are not affected when writing this bit.															
				<table border="1"> <thead> <tr> <th>Value</th> <th>Description</th> </tr> </thead> <tbody> <tr> <td>0</td> <td>Display is not "blanked"</td> </tr> <tr> <td>1</td> <td>Display is "blanked"</td> </tr> </tbody> </table>	Value	Description	0	Display is not "blanked"	1	Display is "blanked"									
Value	Description																		
0	Display is not "blanked"																		
1	Display is "blanked"																		

Bit	Name	Reset	Access	Description
0	BLINKEN	0	RW	Blink Enable When this bit is set, the Blink function is enabled. Every "ON" segment will alternate between on and off at every Frame Counter Event.

29.5.5 LCD_STATUS - Status Register

Offset	Bit Position																															
0x010	31	30	29	28	27	26	25	24	23	22	21	20	19	18	17	16	15	14	13	12	11	10	9	8	7	6	5	4	3	2	1	0
Reset																									0				0x0			
Access																									R				R			
Name																									BLINK			ASTATE				

Bit	Name	Reset	Access	Description
31:9	Reserved	To ensure compatibility with future devices, always write bits to 0. More information in Section 2.1 (p. 3)		
8	BLINK	0	R	Blink State This bits indicates the blink status. If this bit is 1, all segments are off. If this bit is 0, the segments(LCD_SEGDxn) which are set to 1 are on.
7:4	Reserved	To ensure compatibility with future devices, always write bits to 0. More information in Section 2.1 (p. 3)		
3:0	ASTATE	0x0	R	Current Animation State Contains the current animation state (0-15).

29.5.6 LCD_AREGA - Animation Register A (Async Reg)

For more information about Asynchronous Registers please see Section 5.3 (p. 18) .

Offset	Bit Position																															
0x014	31	30	29	28	27	26	25	24	23	22	21	20	19	18	17	16	15	14	13	12	11	10	9	8	7	6	5	4	3	2	1	0
Reset																									0x00							
Access																									RW							
Name																									AREGA							

Bit	Name	Reset	Access	Description
31:8	Reserved	To ensure compatibility with future devices, always write bits to 0. More information in Section 2.1 (p. 3)		
7:0	AREGA	0x00	RW	Animation Register A Data This register contains the A data for generating animation pattern.

29.5.7 LCD_AREGB - Animation Register B (Async Reg)

For more information about Asynchronous Registers please see Section 5.3 (p. 18) .

Offset	Bit Position																															
0x018	31	30	29	28	27	26	25	24	23	22	21	20	19	18	17	16	15	14	13	12	11	10	9	8	7	6	5	4	3	2	1	0
Reset																									0x00							
Access																									RW							
Name																									AREGB							

Bit	Name	Reset	Access	Description
31:8	Reserved	To ensure compatibility with future devices, always write bits to 0. More information in Section 2.1 (p. 3)		
7:0	AREGB	0x00	RW	Animation Register B Data This register contains the B data for generating animation pattern.

29.5.8 LCD_IF - Interrupt Flag Register

Offset	Bit Position																															
0x01C	31	30	29	28	27	26	25	24	23	22	21	20	19	18	17	16	15	14	13	12	11	10	9	8	7	6	5	4	3	2	1	0
Reset																																
Access																																
Name																																

Bit	Name	Reset	Access	Description
31:1	Reserved	To ensure compatibility with future devices, always write bits to 0. More information in Section 2.1 (p. 3)		
0	FC	0	R	Frame Counter Interrupt Flag Set when Frame Counter is zero.

29.5.9 LCD_IFS - Interrupt Flag Set Register

Offset	Bit Position																															
0x020	31	30	29	28	27	26	25	24	23	22	21	20	19	18	17	16	15	14	13	12	11	10	9	8	7	6	5	4	3	2	1	0
Reset																																
Access																																
Name																																

Bit	Name	Reset	Access	Description
31:1	Reserved	To ensure compatibility with future devices, always write bits to 0. More information in Section 2.1 (p. 3)		
0	FC	0	W1	Frame Counter Interrupt Flag Set Write to 1 to set FC interrupt flag.

29.5.10 LCD_IFC - Interrupt Flag Clear Register

Offset	Bit Position																															
0x024	31	30	29	28	27	26	25	24	23	22	21	20	19	18	17	16	15	14	13	12	11	10	9	8	7	6	5	4	3	2	1	0
Reset																																0
Access																																W1
Name																																FC

Bit	Name	Reset	Access	Description
31:1	Reserved	To ensure compatibility with future devices, always write bits to 0. More information in Section 2.1 (p. 3)		
0	FC	0	W1	Frame Counter Interrupt Flag Clear Write to 1 to clear FC interrupt flag.

29.5.11 LCD_IEN - Interrupt Enable Register

Offset	Bit Position																															
0x028	31	30	29	28	27	26	25	24	23	22	21	20	19	18	17	16	15	14	13	12	11	10	9	8	7	6	5	4	3	2	1	0
Reset																																0
Access																																RW
Name																																FC

Bit	Name	Reset	Access	Description
31:1	Reserved	To ensure compatibility with future devices, always write bits to 0. More information in Section 2.1 (p. 3)		
0	FC	0	RW	Frame Counter Interrupt Enable Set to enable interrupt on frame counter interrupt flag.

29.5.12 LCD_SEGD0L - Segment Data Low Register 0 (Async Reg)

For more information about Asynchronous Registers please see Section 5.3 (p. 18) .

Offset	Bit Position																															
0x040	31	30	29	28	27	26	25	24	23	22	21	20	19	18	17	16	15	14	13	12	11	10	9	8	7	6	5	4	3	2	1	0
Reset																																0x00000000
Access																																RW
Name																																SEGD0L

Bit	Name	Reset	Access	Description
31:0	SEGD0L	0x00000000	RW	COM0 Segment Data Low This register contains segment data for segment lines 0-31 for COM0.

29.5.13 LCD_SEGD1L - Segment Data Low Register 1 (Async Reg)

For more information about Asynchronous Registers please see Section 5.3 (p. 18) .

Offset	Bit Position																																
0x044	31	30	29	28	27	26	25	24	23	22	21	20	19	18	17	16	15	14	13	12	11	10	9	8	7	6	5	4	3	2	1	0	
Reset																	0x00000000																
Access																	RW																
Name																	SEGD1L																

Bit	Name	Reset	Access	Description
31:0	SEGD1L	0x00000000	RW	COM1 Segment Data Low This register contains segment data for segment lines 0-31 for COM1.

29.5.14 LCD_SEGD2L - Segment Data Low Register 2 (Async Reg)

For more information about Asynchronous Registers please see Section 5.3 (p. 18) .

Offset	Bit Position																																
0x048	31	30	29	28	27	26	25	24	23	22	21	20	19	18	17	16	15	14	13	12	11	10	9	8	7	6	5	4	3	2	1	0	
Reset																	0x00000000																
Access																	RW																
Name																	SEGD2L																

Bit	Name	Reset	Access	Description
31:0	SEGD2L	0x00000000	RW	COM2 Segment Data Low This register contains segment data for segment lines 0-31 for COM2.

29.5.15 LCD_SEGD3L - Segment Data Low Register 3 (Async Reg)

For more information about Asynchronous Registers please see Section 5.3 (p. 18) .

Offset	Bit Position																															
0x04C	31	30	29	28	27	26	25	24	23	22	21	20	19	18	17	16	15	14	13	12	11	10	9	8	7	6	5	4	3	2	1	0
Reset																	0x00000000															
Access																	RW															
Name																	SEGD3L															

Bit	Name	Reset	Access	Description
31:0	SEGD3L	0x00000000	RW	COM3 Segment Data Low This register contains segment data for segment lines 0-31 for COM3.

29.5.16 LCD_SEGD0H - Segment Data High Register 0 (Async Reg)

For more information about Asynchronous Registers please see Section 5.3 (p. 18) .

Offset	Bit Position																															
0x050	31	30	29	28	27	26	25	24	23	22	21	20	19	18	17	16	15	14	13	12	11	10	9	8	7	6	5	4	3	2	1	0
Reset																	0x00															
Access																	RW															
Name																	SEGD0H															

Bit	Name	Reset	Access	Description
31:8	<i>Reserved</i>			<i>To ensure compatibility with future devices, always write bits to 0. More information in Section 2.1 (p. 3)</i>
7:0	SEGD0H	0x00	RW	COM0 Segment Data High This register contains segment data for segment lines 32-39 for COM0.

29.5.17 LCD_SEGD1H - Segment Data High Register 1 (Async Reg)

For more information about Asynchronous Registers please see Section 5.3 (p. 18) .

Offset	Bit Position																															
0x054	31	30	29	28	27	26	25	24	23	22	21	20	19	18	17	16	15	14	13	12	11	10	9	8	7	6	5	4	3	2	1	0
Reset																	0x00															
Access																	RW															
Name																	SEGD1H															

Bit	Name	Reset	Access	Description
31:8	Reserved	To ensure compatibility with future devices, always write bits to 0. More information in Section 2.1 (p. 3)		
7:0	SEGD1H	0x00	RW	COM1 Segment Data High

This register contains segment data for segment lines 32-39 for COM1.

29.5.18 LCD_SEGD2H - Segment Data High Register 2 (Async Reg)

For more information about Asynchronous Registers please see Section 5.3 (p. 18) .

Offset	Bit Position																															
0x058	31	30	29	28	27	26	25	24	23	22	21	20	19	18	17	16	15	14	13	12	11	10	9	8	7	6	5	4	3	2	1	0
Reset																									0x00							
Access																									RW							
Name																									SEGD2H							

Bit	Name	Reset	Access	Description
31:8	Reserved	To ensure compatibility with future devices, always write bits to 0. More information in Section 2.1 (p. 3)		
7:0	SEGD2H	0x00	RW	COM2 Segment Data High

This register contains segment data for segment lines 32-39 for COM2.

29.5.19 LCD_SEGD3H - Segment Data High Register 3 (Async Reg)

For more information about Asynchronous Registers please see Section 5.3 (p. 18) .

Offset	Bit Position																															
0x05C	31	30	29	28	27	26	25	24	23	22	21	20	19	18	17	16	15	14	13	12	11	10	9	8	7	6	5	4	3	2	1	0
Reset																									0x00							
Access																									RW							
Name																									SEGD3H							

Bit	Name	Reset	Access	Description
31:8	Reserved	To ensure compatibility with future devices, always write bits to 0. More information in Section 2.1 (p. 3)		
7:0	SEGD3H	0x00	RW	COM3 Segment Data High

This register contains segment data for segment lines 32-39 for COM3.

29.5.20 LCD_FREEZE - Freeze Register

Offset	Bit Position																															
0x060	31	30	29	28	27	26	25	24	23	22	21	20	19	18	17	16	15	14	13	12	11	10	9	8	7	6	5	4	3	2	1	0
Reset																																
Access																																
Name																																
																																REGFREEZE

Bit	Name	Reset	Access	Description
31:1	<i>Reserved</i>	<i>To ensure compatibility with future devices, always write bits to 0. More information in Section 2.1 (p. 3)</i>		
0	REGFREEZE	0	RW	Register Update Freeze When set, the update of the LCD is postponed until this bit is cleared. Use this bit to update several registers simultaneously.
	Value	Mode	Description	
	0	UPDATE	Each write access to an LCD register is updated into the Low Frequency domain as soon as possible.	
	1	FREEZE	The LCD is not updated with the new written value.	

29.5.21 LCD_SYNCBUSY - Synchronization Busy Register

Offset	Bit Position																															
0x064	31	30	29	28	27	26	25	24	23	22	21	20	19	18	17	16	15	14	13	12	11	10	9	8	7	6	5	4	3	2	1	0
Reset																																
Access																																
Name																																
																																SEG3H
																																SEG2H
																																SEG1H
																																SEG0H
																																SEG3L
																																SEG2L
																																SEG1L
																																SEG0L
																																AREGB
																																AREGA
																																BACTRL
																																CTRL

Bit	Name	Reset	Access	Description
31:12	<i>Reserved</i>	<i>To ensure compatibility with future devices, always write bits to 0. More information in Section 2.1 (p. 3)</i>		
11	SEGD3H	0	R	LCD_SEGD3H Register Busy Set when the value written to LCD_SEGD3H is being synchronized.
10	SEGD2H	0	R	LCD_SEGD2H Register Busy Set when the value written to LCD_SEGD2H is being synchronized.
9	SEGD1H	0	R	LCD_SEGD1H Register Busy Set when the value written to LCD_SEGD1H is being synchronized.
8	SEGD0H	0	R	LCD_SEGD0H Register Busy Set when the value written to LCD_SEGD0H is being synchronized.
7	SEGD3L	0	R	LCD_SEGD3L Register Busy Set when the value written to LCD_SEGD3L is being synchronized.
6	SEGD2L	0	R	LCD_SEGD2L Register Busy Set when the value written to LCD_SEGD2L is being synchronized.
5	SEGD1L	0	R	LCD_SEGD1L Register Busy Set when the value written to LCD_SEGD1L is being synchronized.
4	SEGD0L	0	R	LCD_SEGD0L Register Busy Set when the value written to LCD_SEGD0L is being synchronized.

Bit	Name	Reset	Access	Description
3	AREGB	0	R	LCD_AREGB Register Busy Set when the value written to LCD_AREGB is being synchronized.
2	AREGA	0	R	LCD_AREGA Register Busy Set when the value written to LCD_AREGA is being synchronized.
1	BACTRL	0	R	LCD_BACTRL Register Busy Set when the value written to LCD_BACTRL is being synchronized.
0	CTRL	0	R	LCD_CTRL Register Busy Set when the value written to LCD_CTRL is being synchronized.

30 Revision History

30.1 Revision 1.10

April 12th, 2011.

Added information about backpowering the MCU if V_{dd} drops below SCL and SDA lines voltage

Added information on behavior after trying to write to locked pages

Added information on ACMP warm up with LPREF

Changed formula in VDDLEVEL bitfield in ACMPn_INPUTSEL

Added sine wave minimum amplitude to BUFEXTCLK.

Changed description of IRQERASEABORT.

Updated description of WARMUPMODE in ADC section.

Fixed description for REFSEL field in CMU_CALCTRL.

Fixed description of RXDATAV and TXBL interrupt flags in CMU.

Added documentation for DMA_CHREQSTATUS, DMA_CHSREQSTATUS.

Renamed DMA_WAITSTATUS to DMA_CHWAITSTATUS and updated bit fields.

Fixed description of ACMP pin output, the GPIO pin must also be set as output.

Removed reference to the DAC LPF and LPFFREQ and LPFEN bitfields in DACn_CTRL.

Added revision C to Table 7.3 (p. 30) .

Changed REFSEL to UPSEL in Figure 11.6 (p. 100) .

Added information to the USART chapter that TXTRI is read as 0 if AUTOTRI is set.

Updated general description of bus system.

Updated frequency limitations when clocking TIMER from external source.

Updated information on disabling of individual LCD segment lines.

30.2 Revision 1.00

September 6th, 2010.

Changed PCNT_TOP reset value.

Parity bits not available for USART synchronous mode.

Corrected Scaled VDD equation in Section 23.3.4 (p. 325) .

DACOUT0 and DACOUT1 in ADCn_SINGLECTRL renamed to DAC0OUT0 and DAC0OUT1.

CH4 in ADCn_SINGLECTRL under DIFF = 1 renamed to DIFF0.

Changed note about minimum acquisition time when sampling $V_{dd}/3$ in Section 25.3.4 (p. 345) .

- Added information about new individual LCD pin disable feature.
- Switched LPFMODE DECAP and RCFILT in ADCn_CTRL register description.
- Added EBI Regions and Peripheral Bit Band Alias to System Address Space in Figure 5.2 (p. 14) .
- Changed VCMP_INPUTCTRL to VCMP_INPUTSEL in Section 24.3.4 (p. 335) , it now complies with register description.
- Corrected conversion time numbers in Section 25.3.2 (p. 343) .
- Changed ENERGMODE to WARMUPMODE in Section 25.3.3 (p. 344) .
- Added Result Resolution column in Table 25.3 (p. 349) .
- Changed ADC calibration routines in Section 25.3.10 (p. 350) .
- Added table with ADC calibration register effect (Table 25.5 (p. 351)).
- Improved ADC Input Filter description and added Figure 25.4 (p. 345) .
- Added minimum supply voltage restrictions when using the 2.5 V and 5 V bandgap references.
- Added note about FULLBIAS and hysteresis level in Section 23.3.2 (p. 324) .
- Removed V_{ss} as possible negative input selection for the analog comparator in Figure 23.1 (p. 323) .
- Improved register description on SCANGAIN, SCANOFFSET, SINGLEGAIN and SINGLEOFFSET fields in ADCn_CAL.
- HPROT[3] and HPROT[2] were removed because there is no cache and bufferable implementation in the system.
- CHPROT is not only 1 bit for the above reason.
- DMA_CONFIG register is W and not RW.
- On the PCNT module, the user does not have to issue LTOPBIM command to load TOPB to TOP so this bit has no effect.
- Corrected AES 128/256 encryption/decryption duration to 54/75 cycles.
- Corrected description of AES byte order for data and key.
- QEM in TIMERN_CTRL renamed to QDM.
- Changed description of COIST in TIMERN_CCx_CTRL.
- Changed DATA0 to CH0DATA and added COMBDATA in PRSEN field description in DACn_CH0CTRL.
- Changed DATA1 to CH1DATA and added COMBDATA in PRSEN field description in DACn_CH1CTRL.
- Renamed Sine Generation Mode to Sine Generator Mode.
- Updated Sine Generator Mode description and added Hi-Z output to Figure 26.3 (p. 369) .
- Changed Table 7.1 (p. 28) , Device Information is not writable by software or debug.
- Removed ATESTIN option from INPUTSEL in ADCn_SINGLECTRL.
- Corrected reset value for PCNTxCLKEN bits in CMU_PCNTCTRL to 0.

30.3 Revision 0.84

February 19th, 2010.

EXTIPSEL16 bitfield in GPIO_EXTIPSELH, renamed to EXTIPSEL15.

AAP information moved from MSC to Debug chapter.

Added description of how to read out device revision number to MSC chapter.

Inserted Links from Register Map to Register Description for each module.

Updated DI table and moved to "Memory and Bus System" Section 5.6 (p. 21) .

Updated Section 11.3.3.2 (p. 99) to include information about AUXHFRCO.

EMU_ATESTCTRL register removed.

AUX field in EMU_AUXCTRL renamed to HRCCLR and shrunk to 1 bit.

All DMA channel registers split into separate bit fields.

All PRS channel registers split into separate bit fields.

SINGLEREP in ADCn_SINGLECTRL renamed to REP.

SINGLEDIFF in ADCn_SINGLECTRL renamed to DIFF.

SINGLEADJ in ADCn_SINGLECTRL renamed to ADJ.

SINGLERES in ADCn_SINGLECTRL renamed to RES.

SINGLESEL in ADCn_SINGLECTRL renamed to INPUTSEL.

SINGLEREF in ADCn_SINGLECTRL renamed to REF.

SINGLEAT in ADCn_SINGLECTRL renamed to AT.

SINGLEPRSEN in ADCn_SINGLECTRL renamed to PRSEN.

SINGLEPRSEL in ADCn_SINGLECTRL renamed to PRSEL.

SCANREP in ADCn_SCANCTRL renamed to REP.

SCANDIFF in ADCn_SCANCTRL renamed to DIFF.

SCANADJ in ADCn_SCANCTRL renamed to ADJ.

SCANRES in ADCn_SCANCTRL renamed to RES.

SCANMASK in ADCn_SCANCTRL renamed to INPUTMASK.

SCANREF in ADCn_SCANCTRL renamed to REF.

SCANAT in ADCn_SCANCTRL renamed to AT.

SCANPRSEN in ADCn_SCANCTRL renamed to PRSEN.

SCANPRSEL in ADCn_SCANCTRL renamed to PRSEL.

SINGLEDATA in ADCn_SINGLEDATA renamed to DATA.

SCANDATA in ADCn_SCANDATA renamed to DATA.

SINGLEDATA in ADCn_SINGLEDATAP renamed to DATAP.

SCANDATAP in ADCn_SCANDATAP renamed to DATAP.

OSRSEL in ADCn_CTRL renamed to OVSRSEL.

Enumeration of OVSRSEL in ADCn_CTRL changed.

Enumeration of RES in ADCn_SINGLECTRL changed.

Enumeration of RES in ADCn_SCANCTRL changed.

Changed access types for RH registers to R (read only).

Enumeration of UDCTRL in LCD_CTRL changed.

CH0EN in DACn_CH0CTRL renamed to EN.

CH0REFREN in DACn_CH0CTRL renamed to REFFREN.

CH0PRSEN in DACn_CH0CTRL renamed to PRSEN.

CH0PRSEL in DACn_CH0CTRL renamed to PRSSEL.

CH1EN in DACn_CH1CTRL renamed to EN.

CH1REFREN in DACn_CH1CTRL renamed to REFFREN.

CH1PRSEN in DACn_CH1CTRL renamed to PRSEN.

CH1PRSEL in DACn_CH1CTRL renamed to PRSSEL.

Enumeration of POSSEL in ACMPn_INPUTSEL changed.

Enumeration of NEGSEL in ACMPn_INPUTSEL changed.

Renamed SWVPEN in GPIO_ROUTE to SWOPEN.

Enumeration of MODE in PCNTn_CTRL changed.

Enumeration of REF in ADCn_SINGLECTRL/ADCn_SCANCTRL changed.

Split DTOGEN in TIMER0_DTOGEN into single bits.

Split DTFSEN in TIMER0_DTFC into single bits.

Split DTFS in TIMER0_DTFAULT into single bits.

Split DTFSC in TIMER0_DTFAULTC into single bits.

DTPRSFSEL0 in TIMER0_DTFC renamed to DTPRS0FSEL.

DTPRSFSEL1 in TIMER0_DTFC renamed to DTPRS1FSEL.

30.4 Revision 0.83

January 25th, 2010.

ENERGYMODE bitfield in ADCn_CTRL, renamed to WARMUPMODE.

Updated enumeration for SCANMASK in ADCn_SCANCTRL.

Updated enumeration for SINGLESEL in ADCn_SINGLECTRL.

Updated enumeration for SCANDATASRC in ADCn_STATUS.

Specified default drive strength for GPIO pins in Section 28.3.1 (p. 394) .

Extracted I²C Slave State Machine into separate section (Section 15.3.9 (p. 157))

Moved specification of resistance values of CSRESEL in ACMPn_CTRL to datasheets.

Corrected DAC clock prescaling equation (Equation 26.1 (p. 367))

30.5 Revision 0.82

November 20th, 2009.

Description of LFXOSEL and LFRCOSEL bits of CMU_STATUS register corrected.

Updated description of EM4 sequence in Table 10.2 (p. 87) .

Updated documentation of WORDTIMEOUT and WDATAREADY in MSC_STATUS.

30.6 Revision 0.81

November 13th, 2009.

Note added to Section 7.3.6 (p. 31) .

Note added to Section 7.3.6 (p. 31) .

Internal reference added to Section 5.6 (p. 21) .

DMA_CHx_CTRL register description updated.

Reference to synchronous pin interrupts removed from Chapter 10 (p. 83) .

ACMP wakeup triggering updated in Chapter 10 (p. 83) .

Internal reference added to note in Section 11.3.1.2 (p. 95) .

Figure 11.4 (p. 98) and Figure 11.5 (p. 99) added.

Section 15.3.7 (p. 150) updated.

Note added in Section 18.3.3 (p. 221) .

Section 25.3.6 (p. 346) added and ADCn_BIASPROG register added.

Section 26.3.3 (p. 367) added and DACn_BIASPROG register added.

Section 26.3.8 (p. 369) updated.

Glitch suppression filter added to Figure 28.1 (p. 394) , Figure 28.2 (p. 395) and Figure 28.4 (p. 396) .

Section 29.3.5 (p. 428) and Section 29.3.6 (p. 429) updated.

LCD_DISPCTRL register updated.

Added PRS example in Section 13.3.4 (p. 129) .

Split CCPEN and CDTIPEN bits in TIMERN_ROUTE into CCxPEN and CDTIxPEN bits.

Description and enumeration of EMVREG in EMU_CTRL updated.

30.7 Revision 0.80

October 19th, 2009.

Initial preliminary revision.

A Abbreviations

A.1 Abbreviations

This section lists abbreviations used in this document.

Table A.1. Abbreviations

Abbreviation	Description
ACMP	Analog Comparator
ADC	Analog to Digital Converter
AHB	AMBA Advanced High-performance Bus. AMBA is short for "Advanced Microcontroller Bus Architecture".
APB	AMBA Advanced Peripheral Bus. AMBA is short for "Advanced Microcontroller Bus Architecture".
ALE	Address Latch Enable
AUXHFRCO	Auxiliary High Frequency RC Oscillator.
CC	Compare / Capture
CLK	Clock
CMD	Command
CMU	Clock Management Unit
CTRL	Control
DAC	Digital to Analog Converter
DBG	Debug
DMA	Direct Memory Access
DTI	Dead Time Insertion
EBI	External Bus Interface
EFM	Energy Friendly Microcontroller
EM	Energy Mode
EM0	Energy Mode 0 (also called active mode)
EM1 to EM4	Energy Mode 1 to Energy Mode 4 (also called low energy modes)
EMU	Energy Management Unit
ENOB	Effective Number of Bits
GPIO	General Purpose Input / Output
HFRCO	High Frequency RC Oscillator
HFXO	High Frequency Crystal Oscillator
HW	Hardware
I ² C	Inter-Integrated Circuit interface
LCD	Liquid Crystal Display
LETIMER	Low Energy Timer
LEUART	Low Energy Universal Asynchronous Receiver Transmitter
LFRCO	Low Frequency RC Oscillator

Abbreviation	Description
LFXO	Low Frequency Crystal Oscillator
NVIC	Nested Vector Interrupt Controller
OSR	Oversampling Ratio
PCNT	Pulse Counter
PRS	Peripheral Reflex System
PWM	Pulse Width Modulation
RC	Resistance and Capacitance
RMU	Reset Management Unit
RTC	Real Time Clock
SAR	Successive Approximation Register
SPI	Serial Peripheral Interface
SW	Software
UART	Universal Asynchronous Receiver Transmitter
USART	Universal Synchronous Asynchronous Receiver Transmitter
VCMP	Voltage supply Comparator
WDOG	Watchdog timer
XTAL	Crystal

B Disclaimer and Trademarks

B.1 Disclaimer

Energy Micro AS intends to provide customers with the latest, accurate, and in-depth documentation of all peripherals and modules available for system and software implementers using or intending to use the Energy Micro products. Characterization data, available modules and peripherals, memory sizes and memory addresses refer to each specific device, and "Typical" parameters provided can and do vary in different applications. Application examples described herein are for illustrative purposes only. Energy Micro reserves the right to make changes without further notice and limitation to product information, specifications, and descriptions herein, and does not give warranties as to the accuracy or completeness of the included information. Energy Micro shall have no liability for the consequences of use of the information supplied herein. This document does not imply or express copyright licenses granted hereunder to design or fabricate any integrated circuits. The products must not be used within any Life Support System without the specific written consent of Energy Micro. A "Life Support System" is any product or system intended to support or sustain life and/or health, which, if it fails, can be reasonably expected to result in significant personal injury or death. Energy Micro products are generally not intended for military applications. Energy Micro products shall under no circumstances be used in weapons of mass destruction including (but not limited to) nuclear, biological or chemical weapons, or missiles capable of delivering such weapons.

B.2 Trademark Information

Energy Micro, EFM32, EFR, logo and combinations thereof, and others are the registered trademarks or trademarks of Energy Micro AS. ARM, CORTEX, THUMB are the registered trademarks of ARM Limited. Other terms and product names may be trademarks of others.

C Contact Information

C.1 Energy Micro Corporate Headquarters

Postal Address	Visitor Address	Technical Support
Energy Micro AS P.O. Box 4633 Nydalen N-0405 Oslo NORWAY	Energy Micro AS Sandakerveien 118 N-0484 Oslo NORWAY	support.energymicro.com Phone: +47 40 10 03 01

www.energymicro.com

Phone: +47 23 00 98 00

Fax: + 47 23 00 98 01

C.2 Global Contacts

Visit **www.energymicro.com** for information on global distributors and representatives or contact **sales@energymicro.com** for additional information.

Americas	Europe, Middle East and Africa	Asia and Pacific
www.energymicro.com/americas	www.energymicro.com/emea	www.energymicro.com/asia

Table of Contents

1. Energy Friendly Microcontrollers	2
1.1. Typical Applications	2
1.2. EFM32G Development	2
2. About This Document	3
2.1. Conventions	3
2.2. Related Documentation	4
3. System Overview	5
3.1. Introduction	5
3.2. Features	5
3.3. Block Diagram	6
3.4. Energy Modes	7
3.5. Product Overview	8
4. System Processor	10
4.1. Introduction	10
4.2. Features	10
4.3. Functional Description	11
5. Memory and Bus System	13
5.1. Introduction	13
5.2. Functional Description	14
5.3. Access to Low Energy Peripherals (Asynchronous Registers)	18
5.4. Flash	20
5.5. SRAM	20
5.6. Device Information (DI) Page	21
6. DBG - Debug Interface	23
6.1. Introduction	23
6.2. Features	23
6.3. Functional Description	23
6.4. Debug Lock and Device Erase	23
6.5. Register Map	25
6.6. Register Description	25
7. MSC - Memory System Controller	27
7.1. Introduction	27
7.2. Features	27
7.3. Functional Description	28
7.4. Register Map	32
7.5. Register Description	32
8. DMA - DMA Controller	38
8.1. Introduction	38
8.2. Features	38
8.3. Block Diagram	39
8.4. Functional Description	39
8.5. Examples	57
8.6. Register Map	59
8.7. Register Description	60
9. RMU - Reset Management Unit	77
9.1. Introduction	77
9.2. Features	77
9.3. Functional Description	77
9.4. Register Map	81
9.5. Register Description	81
10. EMU - Energy Management Unit	83
10.1. Introduction	83
10.2. Features	83
10.3. Functional Description	84
10.4. Register Map	89
10.5. Register Description	89
11. CMU - Clock Management Unit	92
11.1. Introduction	92
11.2. Features	92
11.3. Functional Description	93
11.4. Register Map	101
11.5. Register Description	102
12. WDOG - Watchdog Timer	121
12.1. Introduction	121
12.2. Features	121
12.3. Functional Description	121
12.4. Register Map	123
12.5. Register Description	123
13. PRS - Peripheral Reflex System	126
13.1. Introduction	126
13.2. Features	126

13.3. Functional Description	126
13.4. Register Map	130
13.5. Register Description	130
14. EBI - External Bus Interface	134
14.1. Introduction	134
14.2. Features	134
14.3. Functional Description	134
14.4. Register Map	140
14.5. Register Description	140
15. I ² C - Inter-Integrated Circuit Interface	144
15.1. Introduction	144
15.2. Features	144
15.3. Functional Description	145
15.4. Register Map	165
15.5. Register Description	165
16. USART - Universal Synchronous Asynchronous Receiver/Transmitter	177
16.1. Introduction	177
16.2. Features	177
16.3. Functional Description	178
16.4. Register Map	199
16.5. Register Description	199
17. UART - Universal Asynchronous Receiver/Transmitter	217
17.1. Introduction	217
17.2. Features	217
17.3. Functional Description	218
17.4. Register Description	218
17.5. Register Map	218
18. LEUART - Low Energy Universal Asynchronous Receiver/Transmitter	219
18.1. Introduction	219
18.2. Features	219
18.3. Functional Description	220
18.4. Register Map	231
18.5. Register Description	231
19. TIMER - Timer/Counter	244
19.1. Introduction	244
19.2. Features	244
19.3. Functional Description	245
19.4. Register Map	260
19.5. Register Description	261
20. RTC - Real Time Counter	278
20.1. Introduction	278
20.2. Features	278
20.3. Functional Description	278
20.4. Register Map	282
20.5. Register Description	282
21. LETIMER - Low Energy Timer	287
21.1. Introduction	287
21.2. Features	287
21.3. Functional Description	288
21.4. Register Map	300
21.5. Register Description	300
22. PCNT - Pulse Counter	309
22.1. Introduction	309
22.2. Features	309
22.3. Functional Description	309
22.4. Register Map	315
22.5. Register Description	315
23. ACMP - Analog Comparator	322
23.1. Introduction	322
23.2. Features	322
23.3. Functional Description	323
23.4. Register Map	327
23.5. Register Description	327
24. VCMP - Voltage Comparator	333
24.1. Introduction	333
24.2. Features	333
24.3. Functional Description	334
24.4. Register Map	337
24.5. Register Description	337
25. ADC - Analog to Digital Converter	341
25.1. Introduction	341
25.2. Features	341
25.3. Functional Description	342
25.4. Register Map	352

25.5. Register Description	352
26. DAC - Digital to Analog Converter	365
26.1. Introduction	365
26.2. Features	365
26.3. Functional Description	366
26.4. Register Map	371
26.5. Register Description	371
27. AES - Advanced Encryption Standard Accelerator	380
27.1. Introduction	380
27.2. Features	380
27.3. Functional Description	380
27.4. Register Map	384
27.5. Register Description	384
28. GPIO - General Purpose Input/Output	392
28.1. Introduction	392
28.2. Features	392
28.3. Functional Description	393
28.4. Register Map	399
28.5. Register Description	400
29. LCD - Liquid Crystal Display Driver	414
29.1. Introduction	414
29.2. Features	414
29.3. Functional Description	415
29.4. Register Map	435
29.5. Register Description	435
30. Revision History	447
30.1. Revision 1.10	447
30.2. Revision 1.00	447
30.3. Revision 0.84	449
30.4. Revision 0.83	450
30.5. Revision 0.82	451
30.6. Revision 0.81	451
30.7. Revision 0.80	452
A. Abbreviations	453
A.1. Abbreviations	453
B. Disclaimer and Trademarks	455
B.1. Disclaimer	455
B.2. Trademark Information	455
C. Contact Information	456
C.1. Energy Micro Corporate Headquarters	456
C.2. Global Contacts	456

List of Figures

3.1. Diagram of EFM32G	7
3.2. Energy Mode indicator	7
4.1. Interrupt Operation	11
5.1. EFM32G Bus System	14
5.2. System Address Space	14
5.3. Write operation to Low Energy Peripherals	19
5.4. Read operation form Low Energy Peripherals	20
6.1. AAP - Authentication Access Port	24
7.1. Revision Number Extraction	30
8.1. DMA Block Diagram	39
8.2. Polling flowchart	42
8.3. Ping-pong example	44
8.4. Memory scatter-gather example	47
8.5. Peripheral scatter-gather example	49
8.6. Memory map for 8 channels, including the alternate data structure	51
8.7. Detailed memory map for the 8 channels, including the alternate data structure	52
8.8. channel_cfg bit assignments	53
9.1. RMU Reset Input Sources and Connections.	78
9.2. RMU Power-on Reset Operation	79
9.3. RMU Brown-out Detector Operation	79
10.1. EMU Overview	84
10.2. EMU Energy Mode Transitions	85
11.1. CMU Overview	94
11.2. CMU Switching from HFRCO to HFXO before HFXO is ready	97
11.3. CMU Switching from HFRCO to HFXO after HFXO is ready	98
11.4. HFXO Pin Connection	98
11.5. LFXO Pin Connection	99
11.6. HW-support for RC Oscillator Calibration	100
13.1. PRS Overview	127
13.2. TIMER0 overflow starting ADC0 single conversions through PRS channel 5.	129
14.1. EBI Overview	135
14.2. EBI Non-multiplexed 8-bit Data, 8-bit Address Read Operation	135
14.3. EBI Non-multiplexed 8-bit Data, 8-bit Address Write Operation	136
14.4. EBI Address Latch Setup	136
14.5. EBI Multiplexed 16-bit Data, 16-bit Address Read Operation	136
14.6. EBI Multiplexed 16-bit Data, 16-bit Address Write Operation	137
14.7. EBI Multiplexed 8-bit Data, 24-bit Address Read Operation	137
14.8. EBI Multiplexed 8-bit Data, 24-bit Address Write Operation	137
15.1. I ² C Overview	145
15.2. I ² C-Bus Example	145
15.3. I ² C START and STOP Conditions	146
15.4. I ² C Bit Transfer on I ² C-Bus	146
15.5. I ² C Single Byte Write to Slave	147
15.6. I ² C Double Byte Read from Slave	147
15.7. I ² C Single Byte Write, then Repeated Start and Single Byte Read	147
15.8. I ² C Master Transmitter/Slave Receiver with 10-bit Address	148
15.9. I ² C Master Receiver/Slave Transmitter with 10-bit Address	148
15.10. I ² C Master State Machine	151
15.11. I ² C Slave State Machine	158
16.1. USART Overview	178
16.2. USART Asynchronous Frame Format	179
16.3. USART Transmit Buffer Operation	183
16.4. USART Receive Buffer Operation	185
16.5. USART Sampling of Start and Data Bits	186
16.6. USART Sampling of Stop Bits when Number of Stop Bits are 1 or More	186
16.7. USART Local Loopback	187
16.8. USART Half Duplex Communication with External Driver	188
16.9. USART Transmission of Large Frames	189
16.10. USART Transmission of Large Frames, MSBF	190
16.11. USART Reception of Large Frames	190
16.12. USART ISO 7816 Data Frame Without Error	192
16.13. USART ISO 7816 Data Frame With Error	192
16.14. USART SmartCard Stop Bit Sampling	193
16.15. USART SPI Timing	194
16.16. USART Example RZI Signal for a given Asynchronous USART Frame	197
18.1. LEUART Overview	220
18.2. LEUART Asynchronous Frame Format	221
18.3. LEUART Transmitter Overview	223
18.4. LEUART Receiver Overview	225
18.5. LEUART Local Loopback	228
18.6. LEUART Half Duplex Communication with External Driver	228

18.7. LEUART - NRZ vs. RZI	230
19.1. TIMER Block Overview	246
19.2. TIMER Hardware Timer/Counter Control	247
19.3. TIMER Clock Selection	247
19.4. TIMER Connections	248
19.5. TIMER TOP Value Update Functionality	248
19.6. TIMER Quadrature Encoded Inputs	249
19.7. TIMER Quadrature Decoder Configuration	249
19.8. TIMER X2 Decoding Mode	250
19.9. TIMER X4 Decoding Mode	250
19.10. TIMER Input Pin Logic	251
19.11. TIMER Input Capture Buffer Functionality	251
19.12. TIMER Output Compare/PWM Buffer Functionality	252
19.13. TIMER Input Capture	252
19.14. TIMER Period and/or Pulse width Capture	253
19.15. TIMER Block Diagram Showing Comparison Functionality	253
19.16. TIMER Output Logic	253
19.17. TIMER Up-count Frequency Generation	254
19.18. TIMER Up-count PWM Generation	254
19.19. TIMER Up/Down-count PWM Generation	255
19.20. TIMER Dead-Time Insertion Unit Overview	255
19.21. TIMER Triple Half-Bridge	256
19.22. TIMER Overview of Dead-Time Insertion Block for a Single PWM channel	256
19.23. TIMER Polarity of Both Signals are Set as Active-High	256
19.24. TIMER Output Polarities	257
20.1. RTC Overview	279
21.1. LETIMER Overview	288
21.2. LETIMER State Machine for Free-running Mode	290
21.3. LETIMER One-shot Repeat State Machine	291
21.4. LETIMER Buffered Repeat State Machine	292
21.5. LETIMER Double Repeat State Machine	293
21.6. LETIMER Simple Waveforms Output	295
21.7. LETIMER Repeated Counting	295
21.8. LETIMER Dual Output	295
21.9. LETIMER Triggered Operation	296
21.10. LETIMER Continuous Operation	297
21.11. LETIMER LETIMERn_CNT Not Initialized to 0	298
22.1. PCNT Overview	310
22.2. PCNT Quadrature Coding	311
22.3. PCNT Direction Change Interrupt (DIRCNG) Generation	314
23.1. ACMP Overview	323
23.2. 20 mV Hysteresis Selected	325
23.3. Capacitive Sensing Set-up	326
24.1. VCMP Overview	334
24.2. VCMP 20 mV Hysteresis Enabled	335
25.1. ADC Overview	343
25.2. ADC Conversion Timing	344
25.3. ADC Analog Power Consumption With Different WARMUPMODE Settings	345
25.4. ADC RC Input Filter Configuration	345
25.5. ADC Bias Programming	347
25.6. ADC Conversion Tailgating	348
26.1. DAC Overview	366
26.2. DAC Bias Programming	368
26.3. DAC Sine Mode	369
27.1. AES Key and Data Definitions	381
27.2. AES Data and Key Orientation as Defined in the Advanced Encryption Standard	381
27.3. AES Data and Key Register Operation	382
28.1. Pin Configuration	394
28.2. Tristated Output with Optional Pull-up or Pull-down	395
28.3. Push-Pull Configuration	396
28.4. Open-drain	396
28.5. Pin n Interrupt Generation	397
29.1. LCD Block Diagram	415
29.2. LCD Low-power Waveform for LCD_COM0 in Quadruples Multiplex Mode, 1/3 Bias	416
29.3. LCD Normal Waveform for LCD_COM0 in Quadruples Multiplex Mode, 1/3 Bias	417
29.4. LCD Static Bias and Multiplexing - LCD_COM0	417
29.5. LCD 1/2 Bias and Duplex Multiplexing - LCD_COM0	417
29.6. LCD 1/2 Bias and Duplex Multiplexing - LCD_COM1	418
29.7. LCD 1/2 Bias and Duplex Multiplexing - LCD_SEG0	418
29.8. LCD 1/2 Bias and Duplex Multiplexing - LCD_SEG0 Connection	418
29.9. LCD 1/2 Bias and Duplex Multiplexing - LCD_SEG0-LCD_COM0	418
29.10. LCD 1/2 Bias and Duplex Multiplexing - LCD_SEG0-LCD_COM1	419
29.11. LCD 1/3 Bias and Duplex Multiplexing - LCD_COM0	419
29.12. LCD 1/3 Bias and Duplex Multiplexing - LCD_COM1	419

29.13. LCD 1/3 Bias and Duplex Multiplexing - LCD_SEG0	419
29.14. LCD 1/3 Bias and Duplex Multiplexing - LCD_SEG0 Connection	420
29.15. LCD 1/3 Bias and Duplex Multiplexing - LCD_SEG0-LCD_COM0	420
29.16. LCD 1/3 Bias and Duplex Multiplexing - LCD_SEG0-LCD_COM1	420
29.17. LCD 1/2 Bias and Triplex Multiplexing - LCD_COM0	420
29.18. LCD 1/2 Bias and Triplex Multiplexing - LCD_COM1	421
29.19. LCD 1/2 Bias and Triplex Multiplexing - LCD_COM2	421
29.20. LCD 1/2 Bias and Triplex Multiplexing - LCD_SEG0	421
29.21. LCD 1/2 Bias and Triplex Multiplexing - LCD_SEG0 Connection	421
29.22. LCD 1/2 Bias and Triplex Multiplexing - LCD_SEG0-LCD_COM0	421
29.23. LCD 1/2 Bias and Triplex Multiplexing - LCD_SEG0-LCD_COM1	422
29.24. LCD 1/2 Bias and Triplex Multiplexing - LCD_SEG0-LCD_COM2	422
29.25. LCD 1/3 Bias and Triplex Multiplexing - LCD_COM0	422
29.26. LCD 1/3 Bias and Triplex Multiplexing - LCD_COM1	422
29.27. LCD 1/3 Bias and Triplex Multiplexing - LCD_COM2	423
29.28. LCD 1/3 Bias and Triplex Multiplexing - LCD_SEG0	423
29.29. LCD 1/3 Bias and Triplex Multiplexing - LCD_SEG0 Connection	423
29.30. LCD 1/3 Bias and Triplex Multiplexing - LCD_SEG0-LCD_COM0	423
29.31. LCD 1/3 Bias and Triplex Multiplexing - LCD_SEG0-LCD_COM1	424
29.32. LCD 1/3 Bias and Triplex Multiplexing - LCD_SEG0-LCD_COM2	424
29.33. LCD 1/3 Bias and Quadruplex Multiplexing - LCD_COM0	424
29.34. LCD 1/3 Bias and Quadruplex Multiplexing - LCD_COM1	424
29.35. LCD 1/3 Bias and Quadruplex Multiplexing - LCD_COM2	425
29.36. LCD 1/3 Bias and Quadruplex Multiplexing - LCD_COM3	425
29.37. LCD 1/3 Bias and Quadruplex Multiplexing - LCD_SEG0	425
29.38. LCD 1/3 Bias and Quadruplex Multiplexing - LCD_SEG0 Connection	425
29.39. LCD 1/3 Bias and Quadruplex Multiplexing - LCD_SEG0-LCD_COM0	426
29.40. LCD 1/3 Bias and Quadruplex Multiplexing - LCD_SEG0-LCD_COM1	426
29.41. LCD 1/3 Bias and Quadruplex Multiplexing - LCD_SEG0-LCD_COM2	426
29.42. LCD 1/3 Bias and Quadruplex Multiplexing- LCD_SEG0-LCD_COM3	427
29.43. LCD Clock System in LCD Driver	431
29.44. LCD Block Diagram of the Animation Circuit	433

List of Tables

2.1. Register Access Types	3
3.1. Energy Mode Description	8
3.2. EFM32G Microcontroller Series	9
4.1. Interrupt Request Lines (IRQ)	12
5.1. Memory System Core Peripherals	16
5.2. Memory System Low Energy Peripherals	16
5.3. Memory System Peripherals	17
5.4. Device Information Table	21
7.1. MSC Flash Memory Mapping	28
7.2. Lock Bits Page Structure	29
7.3. Revision Number Interpretation	30
8.1. AHB bus transfer arbitration interval	40
8.2. DMA channel priority	41
8.3. DMA cycle types	42
8.4. channel_cfg for a primary data structure, in memory scatter-gather mode	46
8.5. channel_cfg for a primary data structure, in peripheral scatter-gather mode	48
8.6. Address bit settings for the channel control data structure	51
8.7. src_data_end_ptr bit assignments	52
8.8. dst_data_end_ptr bit assignments	53
8.9. channel_cfg bit assignments	53
8.10. DMA cycle of six words using a word increment	56
8.11. DMA cycle of 12 bytes using a halfword increment	57
9.1. RMU Reset Cause Register Interpretation	78
10.1. EMU Energy Mode Overview	86
10.2. EMU Entering a Low Energy Mode	87
10.3. EMU Wakeup Triggers from Low Energy Modes	88
13.1. Reflex Producers	127
13.2. Reflex Consumers	128
14.1. EBI Timing	138
15.1. I ² C Reserved I ² C Addresses	147
15.2. I ² C Clock Modes	149
15.3. I ² C Interactions in Prioritized Order	152
15.4. I ² C Master Transmitter	154
15.5. I ² C Master Receiver	156
15.6. I ² C STATE Values	157
15.7. I ² C Transmission Status	157
15.8. I ² C Slave Transmitter	160
15.9. I ² C - Slave Receiver	161
15.10. I ² C Bus Error Response	162
16.1. USART Asynchronous vs. Synchronous Mode	179
16.2. USART Pin Usage	179
16.3. USART Data Bits	180
16.4. USART Stop Bits	180
16.5. USART Parity Bits	181
16.6. USART Oversampling	181
16.7. USART Baud Rates @ 4MHz Peripheral Clock	182
16.8. USART SPI Modes	194
16.9. USART IrDA Pulse Widths	197
17.1. UART Limitations	218
18.1. LEUART Parity Bit	221
18.2. LEUART Baud Rates	222
19.1. TIMER Counter Response in X2 Decoding Mode	250
19.2. TIMER Counter Response in X4 Decoding Mode	250
19.3. TIMER Events	259
20.1. RTC Resolution Vs Overflow	280
21.1. LETIMER Repeat Modes	289
21.2. LETIMER Underflow Output Actions	294
22.1. PCNT QUAD Mode Counter Control Function	312
23.1. Bias Configuration	324
24.1. Bias Configuration	334
25.1. ADC Single Ended Conversion	348
25.2. ADC Differential Conversion	349
25.3. Oversampling Result Shifting and Resolution	349
25.4. ADC Results Representation	350
25.5. Calibration Register Effect	351
28.1. Pin Configuration	394
29.1. LCD Mux Settings	416
29.2. LCD BIAS Settings	416
29.3. LCD Wave Settings	416
29.4. LCD Contrast	427
29.5. LCD Contrast Function	427

29.6. LCD Principle of Contrast Adjustment for Different Bias Settings.	428
29.7. LCD V_{LCD}	428
29.8. LCD V_{BOOST} Frequency	429
29.9. LCD Framerate Conversion Table	430
29.10. LCD Update Data Control (UDCTRL) Bits	430
29.11. FCPRESC	431
29.12. LCD Animation Shift Register	432
29.13. LCD Animation Pattern	432
29.14. LCD Animation Example	433
A.1. Abbreviations	453

List of Examples

8.1. DMA Transfer	58
16.1. USART Multi-processor Mode Example	191
19.1. TIMER DTI Example 1	257
19.2. TIMER DTI Example 2	257
21.1. LETIMER Triggered Output Generation	296
21.2. LETIMER Continuous Output Generation	297
21.3. LETIMER PWM Output	298
21.4. LETIMER PWM Output	298
27.1. AES Cipher Block Chaining	383
28.1. Interrupt Example	397
29.1. LCD Event Frequency Example	431
29.2. LCD Animation Enable Example	434
29.3. LCD Animation Dependence Example	434

List of Equations

5.1. Memory SRAM Area Set/Clear Bit	15
5.2. Memory Peripheral Area Bit Modification	15
5.3. Memory Wait Cycles with Clock Equal or Faster than the HFCORECLK	18
5.4. Memory Wait Cycles with Clock Slower than the CPU	18
12.1. WDOG Timeout Equation	122
15.1. I ² C Pull-up Resistor Equation	145
15.2. I ² C Maximum Transmission Rate	149
15.3. I ² C High and Low Cycles Equations	149
16.1. USART Baud Rate	181
16.2. USART Desired Baud Rate	181
16.3. USART Synchronous Mode Bit Rate	193
16.4. USART Synchronous Mode Clock Division Factor	193
18.1. LEUART Baud Rate Equation	222
18.2. LEUART CLKDIV Equation	222
18.3. LEUART Optimal Sampling Point	225
18.4. LEUART Actual Sampling Point	226
19.1. TIMER Rotational Position Equation	250
19.2. TIMER Up-count Frequency Generation Equation	254
19.3. TIMER Up-count PWM Resolution Equation	254
19.4. TIMER Up-count PWM Frequency Equation	254
19.5. TIMER Up-count Duty Cycle Equation	255
19.6. TIMER Up/Down-count PWM Resolution Equation	255
19.7. TIMER Up/Down-count PWM Frequency Equation	255
19.8. TIMER Up/Down-count Duty Cycle Equation	255
20.1. RTC Frequency Equation	279
21.1. LETIMER Clock Frequency	293
23.1. V _{DD} Scaled	325
24.1. VCMP V _{DD} Trigger Level	335
25.1. ADC Total Conversion Time (in ADC_CLK cycles) Per Output	343
25.2. ADC Temperature Measurement	346
26.1. DAC Clock Prescaling	367
26.2. DAC Single Ended Output Voltage	368
26.3. DAC Differential Output Voltage	368
26.4. DAC Sine Generation	369
29.1. LCD Framerate Calculation	429
29.2. LCD Event Frequency Equation	431

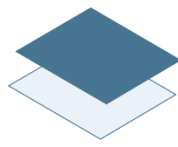

ENERGY[®]
micro

*Energy Micro AS
Sandakerveien 118
P.O. Box 4633 Nydalen
N-0405 Oslo
Norway*

www.energymicro.com