

THIS DRAWING IS UNPUBLISHED. RELEASED FOR PUBLICATION
 © COPYRIGHT - By - ALL RIGHTS RESERVED.

| REVISIONS | | | | | |
|-----------|-----|---------------------------|-----------|-----|------|
| P | LTR | DESCRIPTION | DATE | DWN | APVD |
| | AV6 | REVISED PER ECO-16-004223 | 19JUL2016 | NK | MZ |
| | AW | REVISED PER ECO-16-017462 | 08MAR2017 | RS | MZ |

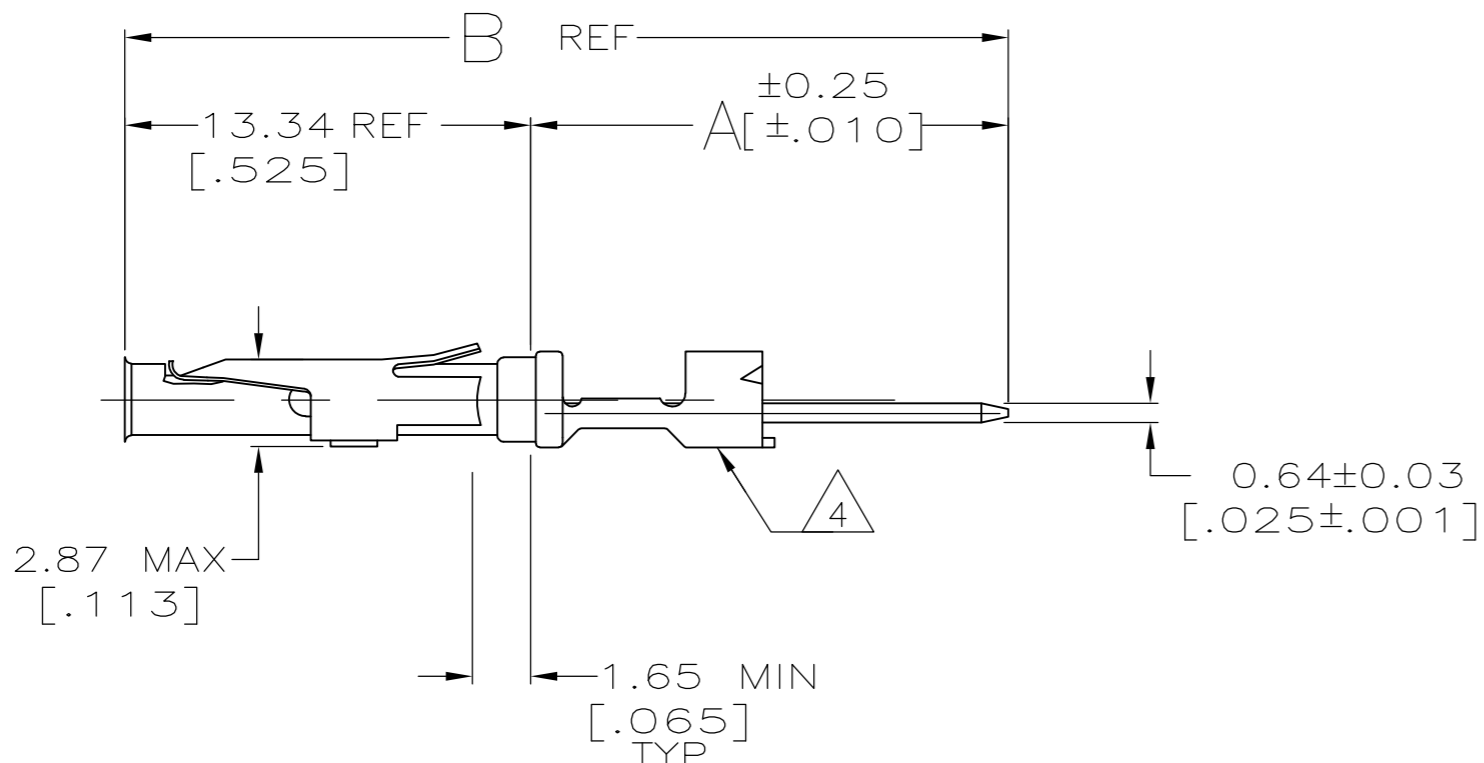
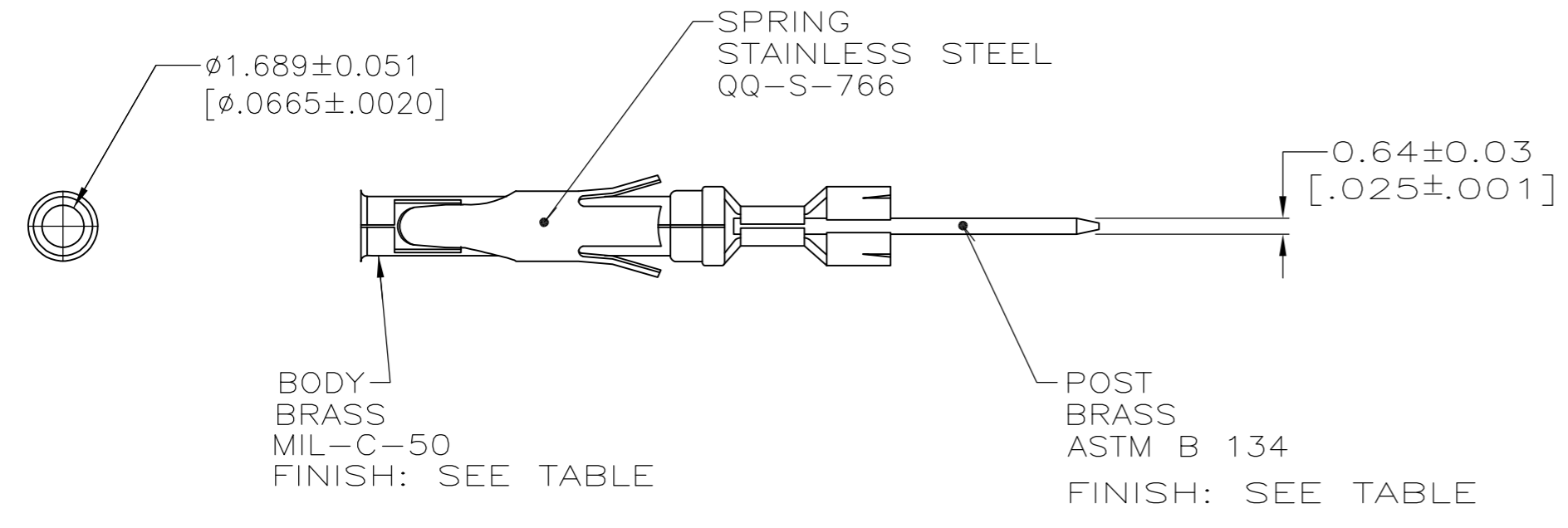

- 1 2.54um [.000100] MIN TIN-LEAD PER MIL-T-10727 OVER
1.27um [.000050] MIN NICKEL PER QQ-N-290.
- 2 2.76um [.000030] MIN GOLD PER MIL-G-45204 ON MATING END FOR
A LENGTH OF 5.08 [.200] MIN WITH A UNIFORM GRADIENT TO 0.25um
[.000010] MIN GOLD PER MIL-G-45204 ON THE REMAINDER OVER
1.27um [.000050] MIN NICKEL PER QQ-N-290.
- 3 2.54um [.000100] MIN TIN-LEAD PER MIL-T-10727 OVER
1.27um [.000050] MIN NICKEL PER QQ-N-290.
- 4 GOLD PLATING NEED NOT APPEAR ON WIRE BARREL.
- 5 0.76um [.000030] MIN GOLD PER MIL-G-45204 ON MATING END FOR
A LENGTH OF 5.08 [.200] MIN, GOLD FLASH ON THE REMAINDER OVER
1.27um [.000050] MIN NICKEL PER QQ-N-290.
- 6 .000100 MIN TIN PER MIL-T-10727, OVER
.000050 MIN NICKEL PER QQ-N-290.
- 7 .000030 MIN GOLD PER MIL-G-45204, OVER
.000050 MIN NICKEL PER QQ-N-290.
- 8 OBSOLETE PARTS: OBSOLETE CIS STREAMLINING PER D.RENAUD/D.SINISI

| | | | | | | | |
|---|-------------|------------------|------------------|------------|-------------|-------------|----------------------|
| | PRELIMINARY | 34.44 [1.356] | 21.11 [.831] | 2 | 7 | 6 | 5-66461-7 |
| | | 29.13 [1.147] | 15.80 [.622] | 1 | 6 | 2 | 5-66461-6 |
| | | 29.13 [1.147] | 15.80 [.622] | 1 | 6 | 5 | 5-66461-5 |
| | | 29.13 [1.147] | 15.80 [.622] | 1 | 6 | 6 | 5-66461-4 |
| | PRELIMINARY | 34.44 [1.356] | 21.11 [.831] | 2 | 3 | 1 | 5-66461-3 |
| | OBSOLETE | 49.40 [1.945] | 36.07 [1.420] | SPECIAL | 3 | 5 | 5-66461-1 |
| 8 | OBSOLETE | 30.68 [1.208] | 17.35 [.683] | SPECIAL | 3 | 1 | 2-66461-2 |
| 8 | SUPERSEDED | 34.44 [1.356] | 21.11 [.831] | 2 | 3 | 1 | 2-66461-1 |
| | OBSOLETE | 41.48 [1.633] | 28.14 [1.108] | SPECIAL | 3 | 5 | 2-66461-0 |
| | | 30.68 [1.208] | 17.35 [.683] | SPECIAL | 3 | 1 | 1-66461-9 |
| | OBSOLETE | 29.64 [1.167] | 16.31 [.642] | SPECIAL | 3 | 5 | 1-66461-8 |
| | OBSOLETE | 27.97 [1.101] | 14.63 [.576] | SPECIAL | 3 | 5 | 1-66461-7 |
| | OBSOLETE | 25.68 [1.011] | 12.34 [.486] | SPECIAL | 3 | 5 | 1-66461-3 |
| | | 43.46 [1.711] | 30.12 [1.186] | SPECIAL | 3 | 5 | 1-66461-0 |
| | | 39.24 [1.545] | 25.91 [1.020] | 3 | 3 | 5 | 66461-9 |
| | | 34.44 [1.356] | 21.11 [.831] | 2 | 3 | 5 | 66461-8 |
| | | 29.13 [1.147] | 15.80 [.622] | 1 | 3 | 5 | 66461-7 |
| | | 39.24 [1.545] | 25.91 [1.020] | 3 | 3 | 2 | 66461-6 |
| | | 34.44 [1.356] | 21.11 [.831] | 2 | 3 | 2 | 66461-5 |
| | | 29.13 [1.147] | 15.80 [.622] | 1 | 3 | 2 | 66461-4 |
| | | 39.24 [1.545] | 25.91 [1.020] | 3 | 3 | 1 | 66461-3 |
| | | 34.44 [1.356] | 21.11 [.831] | 2 | 3 | 1 | 66461-2 |
| | | 29.13 [1.147] | 15.80 [.622] | 1 | 3 | 1 | 66461-1 |
| | | B | A | NO OF TERM | POST FINISH | BODY FINISH | PART NUMBER |

THIS DRAWING IS A CONTROLLED DOCUMENT. DWN 07/02/92
 C.OBERMAN
 CHK 7-8-92
 R.STONE
 APVD 7-10-92
 C.OBERMANN
 PRODUCT SPEC

DIMENSIONS: INCHES TOLERANCES UNLESS OTHERWISE SPECIFIED:
 0 PLC ± -
 1 PLC ± -
 2 PLC ± 0.13 [.005]
 3 PLC ± -
 4 PLC ± -
 ANGLES ± -
 FINISH SEE CALLOUT

MATERIAL SEE CALLOUT

NAME: SOCKET CONTACT, CRIMPED
 .062 DIA, .025 X .025 POST,
 AUTOWIRE

SIZE: A2 CAGE CODE: 00779 DRAWING NO: 66461 RESTRICTED TO: -
 WEIGHT: - SCALE: 4:1 SHEET: 1 OF 2 REV: AW

CUSTOMER DRAWING

THIS DRAWING IS UNPUBLISHED. RELEASED FOR PUBLICATION
 © COPYRIGHT - By - ALL RIGHTS RESERVED.

| REVISIONS | | | | | |
|-----------|-----|-------------|------|-----|------|
| P | LTR | DESCRIPTION | DATE | DWN | APVD |
| - | - | SEE SHEET 1 | - | - | - |
| - | - | SEE TABLE 1 | - | - | - |

| | OBSOLETE | 49.40 [1.945] | 36.07 [1.420] | SPECIAL | △6 | △5 | 9-66461-9 |
|----|----------|------------------|------------------|------------|-------------|-------------|----------------------|
| | | 30.68 [1.208] | 17.35 [.683] | SPECIAL | △6 | △6 | 7-66461-0 |
| △8 | OBSOLETE | 30.68 [1.208] | 17.35 [.683] | SPECIAL | △6 | △6 | 6-66461-5 |
| | | 41.48 [1.633] | 28.14 [1.108] | SPECIAL | △6 | △5 | 6-66461-4 |
| | | 39.24 [1.545] | 25.91 [1.020] | 3 | △6 | △5 | 6-66461-3 |
| | | 34.44 [1.356] | 21.11 [.831] | 2 | △6 | △5 | 6-66461-2 |
| △8 | OBSOLETE | 39.24 [1.545] | 25.91 [1.020] | 3 | △6 | △2 | 6-66461-1 |
| | | 34.44 [1.356] | 21.11 [.831] | 2 | △6 | △2 | 6-66461-0 |
| | | 39.24 [1.545] | 25.91 [1.020] | 3 | △6 | △6 | 5-66461-9 |
| | | 34.44 [1.356] | 21.11 [.831] | 2 | △6 | △6 | 5-66461-8 |
| | | B | A | NO OF TERM | POST FINISH | BODY FINISH | PART NUMBER |

| | | | | |
|--|--|--|----------------------------|-----------------------|
| THIS DRAWING IS A CONTROLLED DOCUMENT. | | DWN C.OBERMAN 07/02/92 | STE TE Connectivity | |
| | | CHK R.STONE 7-8-92 | | |
| | | APVD C.OBERMANN 7-10-92 | NAME | |
| DIMENSIONS: INCHES | | TOLERANCES UNLESS OTHERWISE SPECIFIED: | PRODUCT SPEC | |
| | | 0 PLC ± - | APPLICATION SPEC | |
| | | 1 PLC ± - | - | |
| MATERIAL SEE CALLOUT | | FINISH SEE CALLOUT | WEIGHT - | RESTRICTED TO - |
| | | SIZE A2 | CAGE CODE 00779 | DRAWING NO C-66461 |
| | | CUSTOMER DRAWING | | SCALE 4:1 |
| | | SHEET 2 of 2 | | REV AW |