

Montageausschnitt M1:1  
Panel Cutout

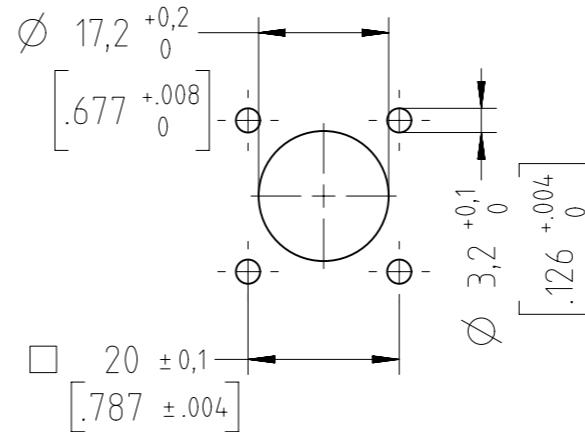

Dichtfläche eben und gratfrei, geeignete Schraubenabdichtung ist vorzusehen / Sealing area must be flat and polished. provide suitable sealing for the screws

max. Überstand der Kontakte 1,0mm  
maximum overlap of the contacts 1,0mm

Number of contacts	Standard	3	4	5	5S	6	7	7	8	12	14	
Contact arrangement	DIN EN 61076-2-106	03-a	04-a	05-a	05-b	06-a	07-a	07-b	08-a	12-a	14-a	
Contact arrangement	IEC 60130-9 <sup>1)</sup>											
Rated voltage <sup>2)</sup>	IEC 60664-1	300 V (100 V)	300 V (63 V)	100 V (32 V)	300 V (63 V)	100 V (32 V)	150 V (32 V)					
Rated voltage	UL 1977	250 V						60 V				
Rated impulse withstand voltage <sup>2)</sup>	IEC 60664-1	1500 V (840 V)	1200 V (500 V)	1500 V (840 V)	1200 V (500 V)							
Pollution degree <sup>2)</sup>	IEC 60664-1	1 (3 <sup>3)</sup> )										
Installation category	IEC 60664-1	I										
Insulation group	IEC 60664-1	II, 400 ≤ CTI < 600										
Current rating	IEC 60512-5-2 UL 1977	10A/+40°C/+104°F		7A/+40°C/+104°F				3A/+40°C/+104°F				
Insulation resistance	IEC 60512-3-1	>10 <sup>10</sup> Ohm <sup>4)</sup>										
Contact resistance	IEC 60512-2-1	<5m Ohm										
Climatic category	IEC 60668-1	40 / 100 / 56										
Temperatur range	IEC 60668-1	-40°C...+100°C / -40°F...+212°F										
salt spray resistance	DIN IEC 60068-2-11	720h										
IP degree	IEC 60529	IP 69K / IP 67 / IP 65 (in mated condition)										
Insertion and withdrawal force	IEC 60512-13-2	25N	30N	35N	50N	55N	60N	50N				
Mechanical operation	IEC 60512-9-1	silver ≥500 mating cycles gold ≥1000 mating cycles										
Housing material		brass and / or zinc die cast, nickel plated										
Dielectric material		thermoplastic										
Contacts		silver or gold plated, please order contacts separately acc. to drawing M-N 01 015 00XX X (3-8pol) or M-N 01 010 0158 X U (12-14pol)										
Termination technique		solder, crimp										
Wire gauge		2-6 pol (exclusive 5S): 0,09-1,0mm <sup>2</sup> / 28-18 AWG						0,09-0,25mm <sup>2</sup> / 28-24 AWG				
Flamability		UL 94 V0										
locking system	IEC 60130-9 DIN EN 61076-2-106	metal screw coupling; tightening torque 1,0 - 1,5 Nm										

<sup>1)</sup> Edition 2000-05  
<sup>2)</sup> values in brackets are according to DIN EN 61076-2-106  
<sup>3)</sup> designed acc. pollution degree 2; can be used under pollution degree 3 when the rules of IEC 60664-1 are fulfilled  
<sup>4)</sup> under operating conditions >10<sup>8</sup> Ohm  
<sup>5)</sup> Remark for gold plated contacts: In order to avoid brittle inter-metallic connections, gold-plated terminals have to be tin-plated in the solder area.

All technical data have been measured in a laboratory environment and can be different during practical usage of the product. Any product information is for descriptive usage only and not legally binding; particularly the information does not constitute or provide any legal guaranties. Do not connect or disconnect under load. Metal housing parts shall be securely incorporated to protected ground. Parts according to directive 2002/95/EG (RoHS).

	14 (14-a)	C091 11S014 000 2 U
	12 (12-a)	C091 11S012 000 2 U
	8 (08-a)	C091 11S008 000 2 U
	7 (07-b)	C091 11S107 000 2 U
	7 (07-a)	C091 11S007 000 2 U
	6 (6-a)	C091 11S006 000 2 U
	5 (05-b)	C091 11S105 000 2 U
	5 (05-a)	C091 11S005 000 2 U
	4 (04-a)	C091 11S004 000 2 U
	3 (03-a)	C091 11S003 000 2 U
<b>Contact arrangement View on mating side</b>	Number of contacts (Contact arrangement acc. DIN EN 61076-2-106)	<b>Part number</b>

Gewicht (errechnet) / Calc WT: 0,014 kg	Zul. Abw./Tolerances:	Maßstab / Scale: 2:1; 1:1	A3	
Prüfmaß / Testdimension		<b>CUSTOMER DRAWING</b>		
Teilindex Partindexnumber				
Datum/Date	Name	Male receptacle Male receptacle		
08.06.2016	RSCHÄ			
Status: Released Inspector: 07.07.2016 MGRIM		M C091 11SXXX 000 2 U		
Amphenol-Tuchel Electronics GmbH				
03	201600320	08.06.2016	RSCHÄ	Blatt/Sheet 1
Index	Änderung/Description	Datum/Date	Name	1 Bl.
		4.033.377		Ers. f. l. Replacement for: M-C091 11SXXX 000 2 U Rev02

Weitergabe sowie Vervielfältigung dieser Unterlage, Verwertung und Mitteilung ihres Inhalts nicht gestattet, soweit nicht ausdrücklich zugestanden. Zuwiderhandlungen verpflichten zu Schadenersatz. Alle Rechte für den Fall der Patenterteilung oder Gebrauchsmuster-Eintragung vorbehalten.