

THIS DRAWING IS UNPUBLISHED. RELEASED FOR PUBLICATION
 © COPYRIGHT BY TYCO ELECTRONICS CORPORATION. ALL RIGHTS RESERVED.

LOC		DIST		REVISIONS			
P	LTR	DESCRIPTION	DATE	DWN	APVD		
	C1	PER ECO-09-026299	25Nov2009	AM	BOB		

DESIGNED FOR USE WITH RD-316/U (DOUBLE BRAID CABLE)
 CABLE ENTRY DIAMETER MINIMUM

FERRULE	.137
HOUSING	.067
CONTACT	.023

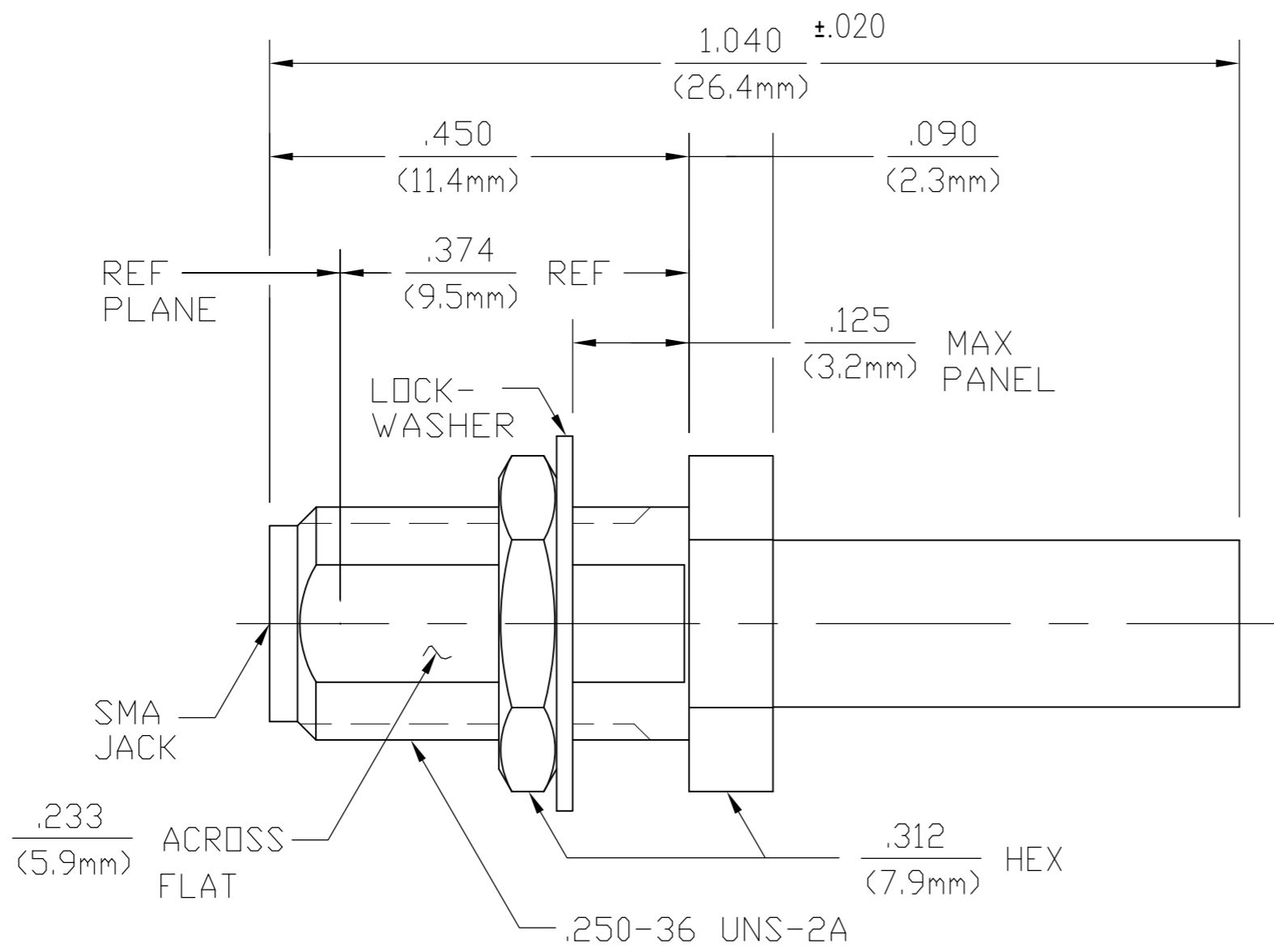

NOTE:
 1. ASSEMBLE TO CABLE USING IS 408-4661 (AP28-001)

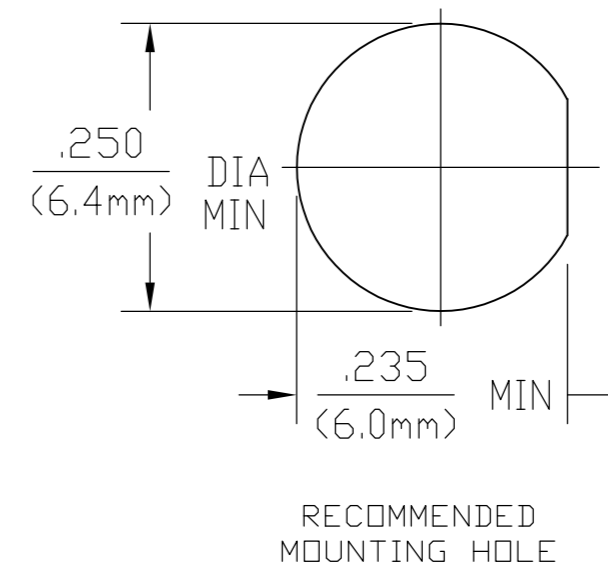

- 1 BRASS
- 2 STAINLESS STEEL
- 3 PHOSPHOR BRONZE
- 4 PTFE
- 5 GOLD PLATE
- 6 NICKEL PLATE
- 7 PASSIVATE

ELECTRICAL	MECHANICAL	ENVIRONMENTAL
Nominal Impedance (Ohms) 50	Interface Dimensions MIL-STD-348A, Fig. 310.2	TEMPERATURE RATING -65°C TO + 165°C
Frequency Range (GHz) DC to 12.4	Recommended Mating Torque N/A	DURABILITY: 500 CYCLES
Volt Rating (VRMS MAX) @ Sea Level 250	Mating Characteristics:	
VSWR 1.30 : 1	Insertion (MAX lbs) 3.0	
Insertion Loss (dB MAX) .06 √f(GHz)	Withdrawal (MIN oz) 1.0	
RF Leakage (dB MIN) -[60-f(GHz)]	Force to Engage and Disengage (in-lbs MAX) 2.0	
Corona, 70,000 Ft (VRMS MIN) 190	Center Contact Captivation:	
Dielectric Withstanding Voltage (VRMS MIN) @ Sea Level 750	Axial (lbs) 6.0	
Contact Resistance (Milliohms MAX):	Radial (in-oz) N/A	
Center Contact 2.0	Cable Retention:	
Outer Contact 2.0	Axial Force (lbs MIN) 25.0	
Cable to Housing 0.5	Torque (in-oz MIN) N/A	
RF High Potential @ Sea Level (VRMS MIN @ 5 MHz) 500	Weight (Grams) TBD	
I.R.(Megohms MIN) 10,000		

1 6	3 6	4	1 5	1 6	1 6	1056445-3
2 7	2 7	4	1 5	1 6	2 7	1056445-1
HOUSING	LOCKWASHER	DIELECTRIC	CENTER CONTACT	FERRULE	MOUNTING NUT	TE PN.

THIS DRAWING IS A CONTROLLED DOCUMENT.		DWN TMD 11/16/92	Tyco Electronics Corporation Norwood, MA 02062			
DIMENSIONS: INCHES		CHK -	NAME SMA BULKHEAD CABLE JACK CRIMP ATTACHMENT			
TOLERANCES UNLESS OTHERWISE SPECIFIED:		APVD DCam 12/15/92	SIZE A2 CAGE CODE 00779 DRAWING NO C=1056445			
0 PLC ± -		PRODUCT SPEC 108-112002	RESTRICTED TO -			
1 PLC ± -		APPLICATION SPEC 408-4661	SCALE 6:1 SHEET 1 OF 1 REV C1			
2 PLC ± -		WEIGHT -				
3 PLC ± .005		CUSTOMER DRAWING				
4 PLC ± - ± 1						
ANGLES ± 1						
FINISH -						