

Microphone coupon board based on the MP34DB02 digital MEMS microphone

Data brief

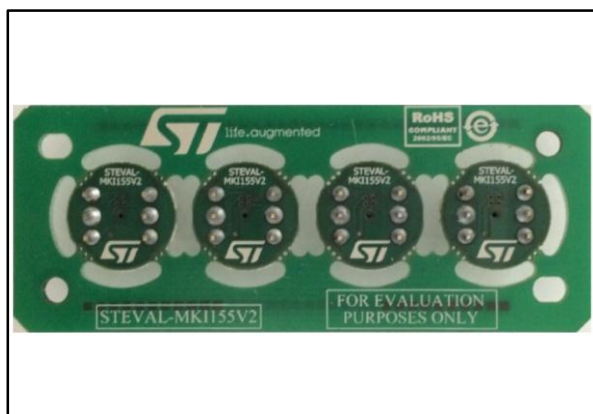

Description

The STEVAL-MKI155V2 board is a daughterboard to be used with the STEVAL-MKI126Vx (Smart Voice) kit, containing 4 MP34DB02 digital MEMS microphones. The coupon concept allows easy performance testing of ST MEMS microphones. When connected to the Smart Voice board, it is possible to detach the single PCBs hosting each microphone.

Features

- 4 x MP34DB02 bottom port digital MEMS microphones
- Functions as a daughterboard for use with STEVAL-MKI126Vx kit
- V supply from 1.64 to 3.6 V
- 120 dB SPL acoustic overload point
- Omnidirectional sensitivity
- PDM single-bit output
- 62.6 dB of SNR
- Sensitivity: -26 dBFS
- RoHS compliant

1 Schematic diagram

Figure 1: STEVAL-MKI155V2 circuit schematic

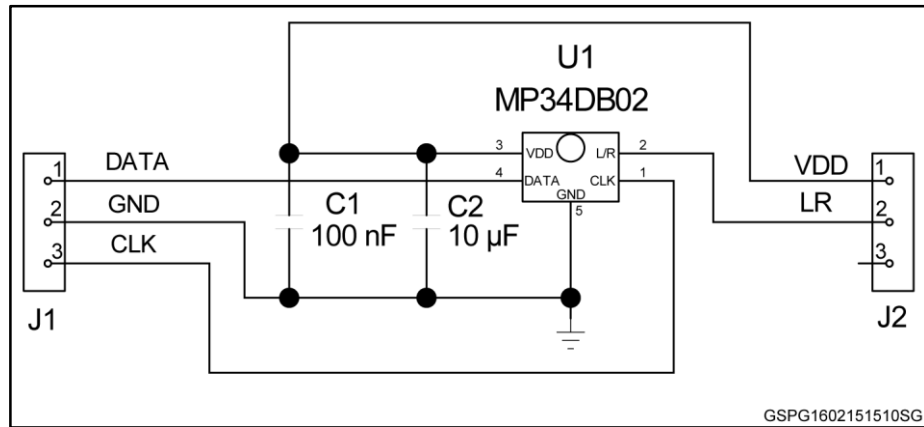

2 Revision history

Table 1: Document revision history

Date	Rev	Changes
24-Feb-2015	1	First release.
02-Mar-2015	2	Updated: Figure 1 STEVAL-MKI155V2 circuit schematic

IMPORTANT NOTICE – PLEASE READ CAREFULLY

STMicroelectronics NV and its subsidiaries ("ST") reserve the right to make changes, corrections, enhancements, modifications, and improvements to ST products and/or to this document at any time without notice. Purchasers should obtain the latest relevant information on ST products before placing orders. ST products are sold pursuant to ST's terms and conditions of sale in place at the time of order acknowledgement.

Purchasers are solely responsible for the choice, selection, and use of ST products and ST assumes no liability for application assistance or the design of Purchasers' products.

No license, express or implied, to any intellectual property right is granted by ST herein.

Resale of ST products with provisions different from the information set forth herein shall void any warranty granted by ST for such product.

ST and the ST logo are trademarks of ST. All other product or service names are the property of their respective owners.

Information in this document supersedes and replaces information previously supplied in any prior versions of this document.

© 2015 STMicroelectronics – All rights reserved