

### General Description

The QPA9801 is a balanced amplifier module with embedded hybrid couplers to convert to single ended input and output ports. The module has an enable pin to allow for shutting down of the amplifier. The module requires minimal external components which are VCC choke inductors, decoupling caps and resistors for bias control.

The QPA9801 provides 26 dBm P1dB with 20 dB gain and 42 dBm OIP3 across a wide frequency range of 1805-2400 MHz to cover the 3GPP Bands 1, 2, 3, 4, 10, 23 and 30. The linear driver amplifier is targeted for use in wireless infrastructure where high linearity, medium power and high integration is required. The balanced amplifier configuration provides very good input and output VSWR and is especially ideal as the output stage in a macrocell transceiver board that connects to the high power amplifier (HPA) board through a long cable or microstrip trace. The QPA9801 is packaged in a small 5 x 5 mm leadless package that is internally matched to 50 Ω on all RF ports.

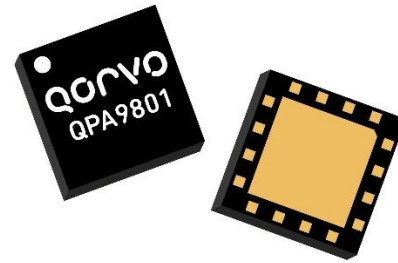

16 Pad 5 x 5 mm leadless SMT Package

### Product Features

- 1805 – 2400 MHz
- Balanced Amplifier with integrated 3 dB hybrids
- Internally Matched 50 Ω Input / Output
- Shutdown Mode with 1.8V logic control
- 20 dB Gain
- +41.6 dBm OIP3
- +26.4 dBm P1dB
- Good gain flatness across Bands 1, 2, 3, 4, 10, 23, 30

### Functional Block Diagram

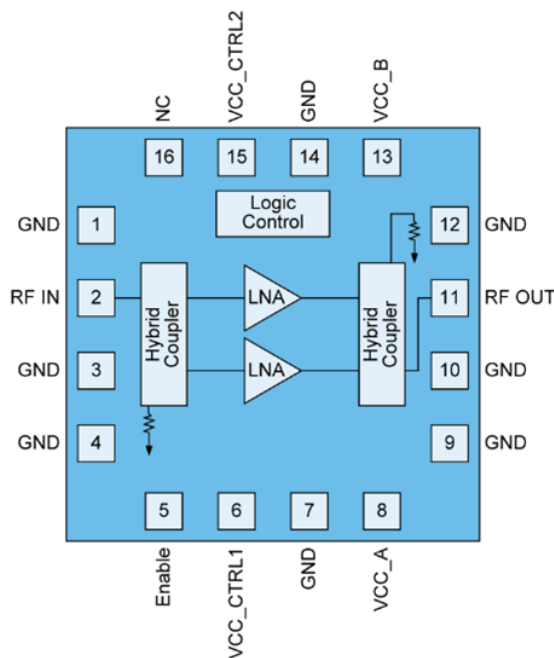

Top View

### Applications

- Wireless Infrastructure
- Macro BTS Transceivers
- Booster Amps, Repeaters

### Ordering Information

Part No.	Description
QPA9801TR13	2,500 pieces on a 13" reel (standard)
QPA9801SR	100 pieces on a 7" reel
QPA9801PCB401	1805 – 2400 MHz Evaluation Board

## Absolute Maximum Ratings

Parameter	Rating
Storage Temperature	-40 to +150 °C
RF Input Power, CW, 50 Ω, T=25 °C	+22 dBm
Supply Voltage (V <sub>CC</sub> )	+6 V
Enable Voltage (Enable)	+5.5 V

Exceeding any one or a combination of the Absolute Maximum Rating conditions may cause permanent damage to the device. Extended application of Absolute Maximum Rating conditions to the device may reduce device reliability.

## Recommended Operating Conditions

Parameter	Min	Typ	Max	Units
Device Voltage (V <sub>CC</sub> )	+3.30	+5	+5.25	V
Enable (High)	+1.17	+1.8	+3.6	V
Enable (Low)	0		+0.63	V
T <sub>CASE</sub>	-40		+105	°C
T <sub>j</sub> for >10 <sup>6</sup> hours MTTF			+190	°C

Electrical specifications are measured at specified test conditions. Specifications are not guaranteed over all recommended operating conditions.

## Electrical Specifications

Parameter	Conditions <sup>(1)</sup>	Min	Typ	Max	Units
Operational Frequency Range		1805		2400	MHz
Test Frequency			2140		MHz
Gain		18.5	20	21.5	dB
Gain Slope (peak to peak)	F <sub>c</sub> ± 100 MHz		0.1		dB
	F <sub>c</sub> ± 250 MHz		0.3		dB
	F <sub>c</sub> ± 350 MHz		0.6		dB
	F <sub>c</sub> ± 500 MHz		1.0		dB
Output IP3	Pin = -7 dBm/tone, Δf = 1 MHz	+38.5	+41.6		dBm
Output P1dB		+25.0	+26.4		dBm
Noise Figure			1.5		dB
Input Return Loss			23		dB
Output Return Loss			25		dB
Control Current	V <sub>CC_CTRL1</sub> (Pin 6)		2		mA
Total Current			296	360	mA
Rise time	From Enable to 90% RF		24		nS
Fall time	From Disable to 10% RF		70		nS
Thermal Resistance, θ <sub>jc</sub>	Module (channel to case)			16.2	°C/W

Notes:

1. Test conditions unless otherwise noted: V<sub>CC</sub> = V<sub>CC\_CTRL1</sub> = +5.0V, Enable = +1.8V, Temp = +25 °C, 50 Ω system.

## Logic Table

Parameter	High	Low
Enable	Active	Shutdown

### Application Circuit Schematic and Layout

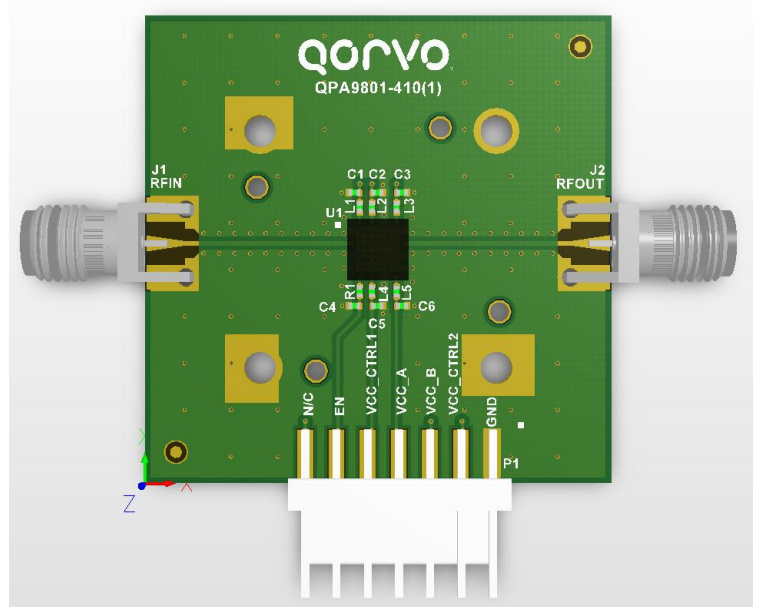
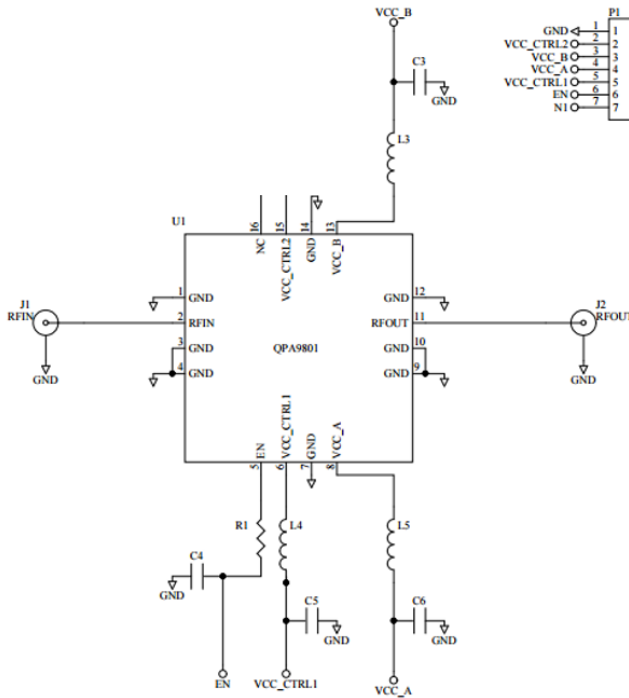

### Bill of Material – QPA9801PCB4B01

Reference Des.	Value	Description	Manuf.	Part Number
n/a	n/a	Printed Circuit Board		
U1	n/a	¼ Watt Balanced Amplifier	Qorvo	QPA9801
L3, L5	68 nH	Inductor, wire wound	Coilcraft	0402CS-68NXGRW
R1, L4	0 Ω	Resistor, Chip, Jumper	Various	
C3, C6	1 uF	Capacitor, Chip, 10%, 10V, X5R	Various	
C5	100 pF	Capacitor, Chip, NPO, 5%, 50V, NPO/COG	Various	
C4		DNI		

## Typical Performance

Parameter	Conditions <sup>(1)</sup>	Typical Value				Units
Frequency		1840	1960	2140	2350	MHz
Gain		20.1	20.2	20.2	19.9	dB
Gain Slope (peak to peak)	Fc ± 100 MHz	0.2	0.1	0.1	0.4	dB
	Fc ± 250 MHz	0.5	0.3	0.3	0.9	dB
	Fc ± 350 MHz	0.7	0.5	0.6	1.3	dB
	Fc ± 500 MHz	1.1	0.8	1.0	2.2	dB
Input Return Loss		20	23	22	22	dB
Output Return Loss		27	25	21	22	dB
Output IP3	Pout = +12 dBm/tone, Δf = 1 MHz	+42.0	+41.1	+40.0	+38.7	dBm
Output P1dB		+26.4	+26.7	+26.4	+26.1	dBm
Noise Figure		1.7	1.5	1.5	1.9	dB

**Notes:**

1. Test conditions unless otherwise noted:  $V_{CC} = V_{CC\_CTRL1} = +5.0V$ , Enable = +1.8V, Temp.=+25 °C

### Performance Plots

Test conditions unless otherwise noted:  $V_{CC} = V_{CC\_CTRL1} = +5V$ , Enable = +1.8 V, Temp. = +25 °C

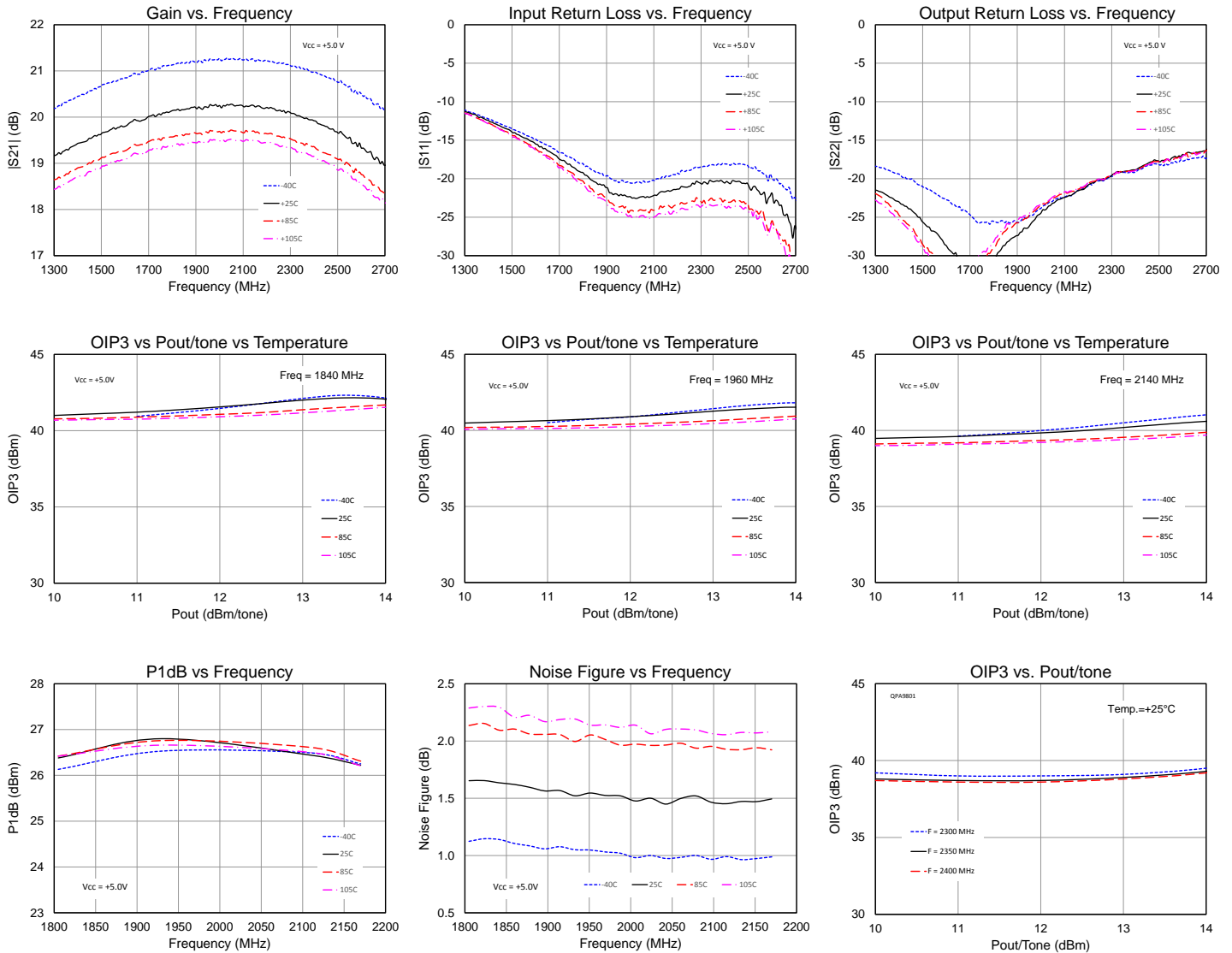



# QPA9801

## 1805 – 2400 MHz 1/4W Balanced Amplifier

### Typical Performance – $V_{CC} = +3.6\text{ V}$

Parameter	Conditions <sup>(1)</sup>	Typical Value			Units
Frequency		1840	1960	2140	MHz
Gain		20.1	20.2	20.2	dB
Gain Slope (peak to peak)	Fc ± 100 MHz	0.2	0.1	0.1	
	Fc ± 250 MHz	0.5	0.3	0.3	dB
	Fc ± 350 MHz	0.7	0.5	0.5	dB
	Fc ± 500 MHz	1.1	0.8	1.0	dB
Input Return Loss		20	23	22	dB
Output Return Loss		27	26	24	dB
Output IP3	Pout = +12 dBm/tone, $\Delta f = 1\text{ MHz}$	+37.0	+37.0	+37.0	dBm
Output P1dB		+23.0	+23.3	+23.1	dBm
Noise Figure		1.6	1.5	1.4	dB

Notes:

1. Test conditions unless otherwise noted:  $V_{CC} = V_{CC\_CTRL1} = +3.6\text{ V}$ , Enable = +1.8V, Temp.=+25 °C

### Performance Plots – $V_{CC} = +3.6\text{ V}$

Test conditions unless otherwise noted:  $V_{CC} = V_{CC\_CTRL1} = +3.6\text{ V}$ , Enable = +1.8 V, Temp. = +25 °C

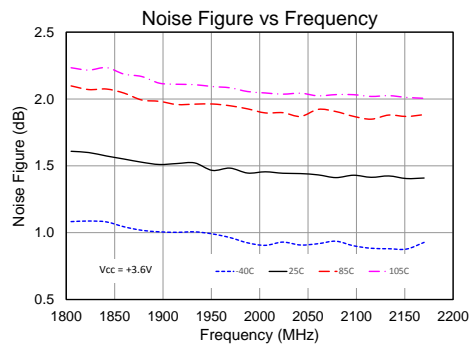
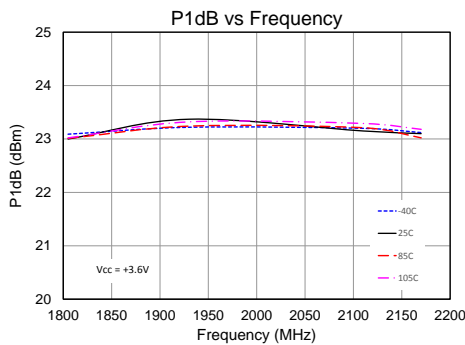
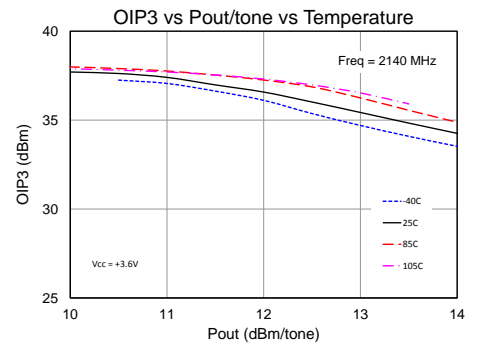
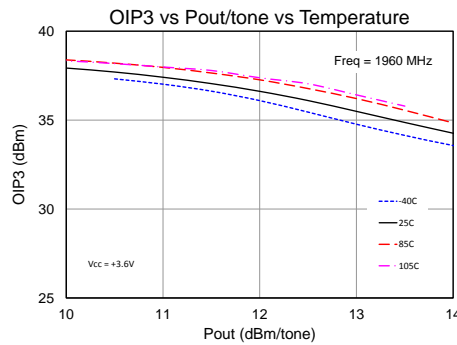
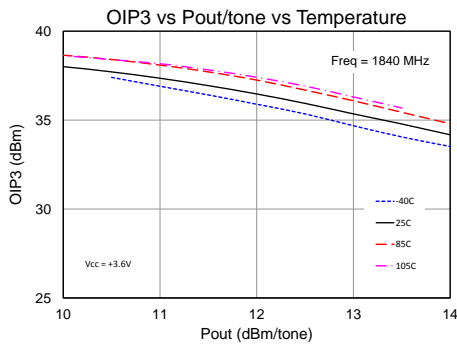
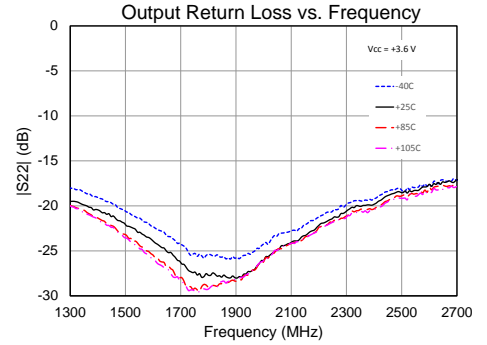
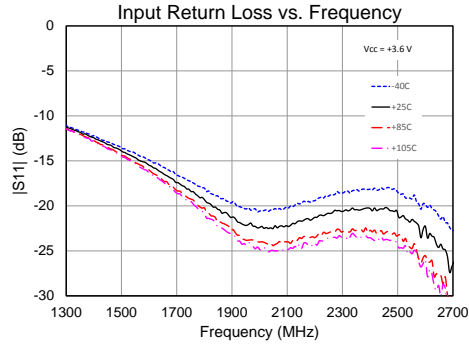
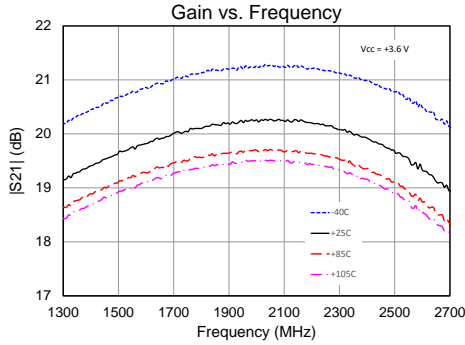

### Application Note – Reduced Bias Performance

The QPA9801 can be configured to be operated with lower bias current either by lowering  $V_{CC\_CTRL1}$  or by replacing L4 with a resistor and leaving  $V_{CC\_CTRL1} = V_{CC}$ . Typical performance is displayed below for various quiescent current settings.

### Typical Performance – Reduced Bias

$V_{CC\_CTRL1}$ (V)	$I_{CQ}$ (mA)	NF (dB)	P1dB (dBm)	OIP3 (dBm)
4.8	250	1.5	+25.9	+42.0
4.6	240	1.5	+25.8	+41.6
4.3	230	1.5	+25.7	+41.0
4.1	220	1.5	+25.4	+40.6
3.9	210	1.5	+25.3	+40.2
3.7	200	1.5	+25.2	+39.7

Frequency = 2140 MHz

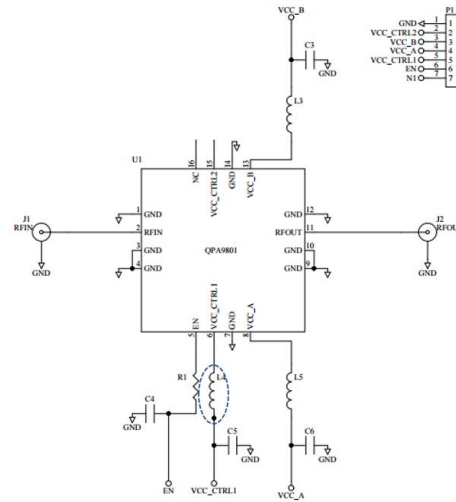

### Performance Plot

Test conditions unless otherwise noted:  $V_{CC} = +5.0$  V, Enable = +1.8 V, Temp. = +25 °C

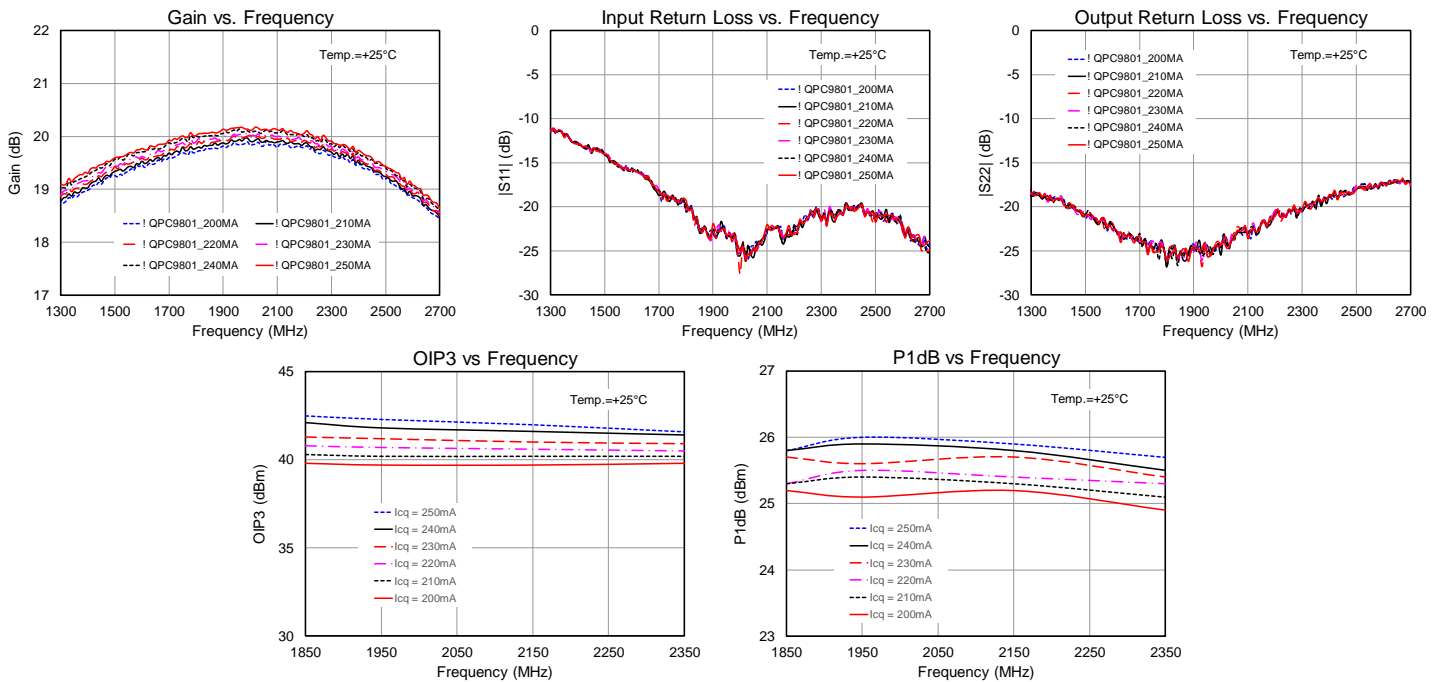



### Pin Configuration and Description

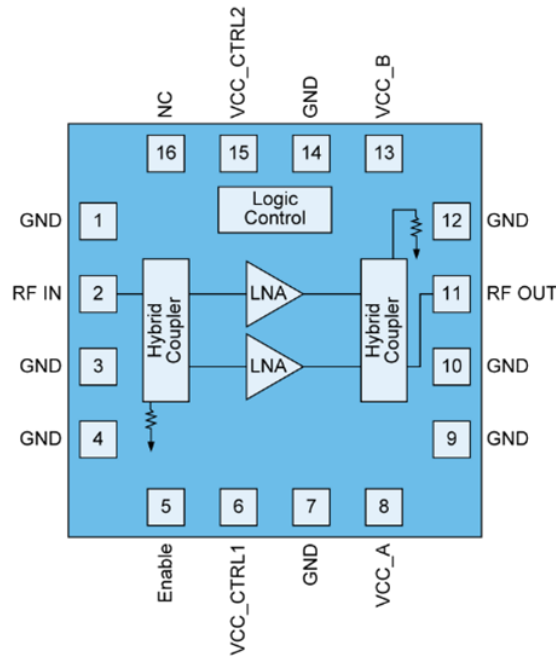

Top View

Pad No.	Label	Description
1, 3, 4, 7, 9, 10, 12, 14	GND	RF and DC Ground
2	RFin	RF Input; Internally 50 Ω matched
5	Enable	Enable pin to turn off amplifiers, 1- ON, 0 – OFF
6	VCC_CTRL1	Supply Voltage for control circuitry
8	VCC_A	Supply Voltage to Amplifier A
11	RFout	RF Output; Internally 50 Ω matched
13	VCC_B	Supply Voltage to Amplifier B
15	NC	Not connected
16	VCC_CTRL2	Not connected
Backside Paddle		RF/DC ground. See PCB Mounting Pattern for suggested footprint.

### Evaluation Board PCB Information

#### PC Board Layout

PCB Material (stackup):

- 1/2 oz. Cu top layer
- 0.008 inch FR-4
- 1 oz. Cu middle layer 1
- .012 inch FR-4
- 1 oz. Cu middle layer 2
- 0.008 inch FR-4
- 1/2 oz. Cu bottom layer
- Finished board thickness is 0.034±.003

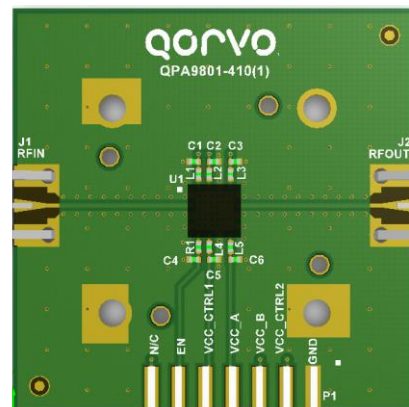

### Package Marking and Dimensions

Marking: Part Number – QPA9801

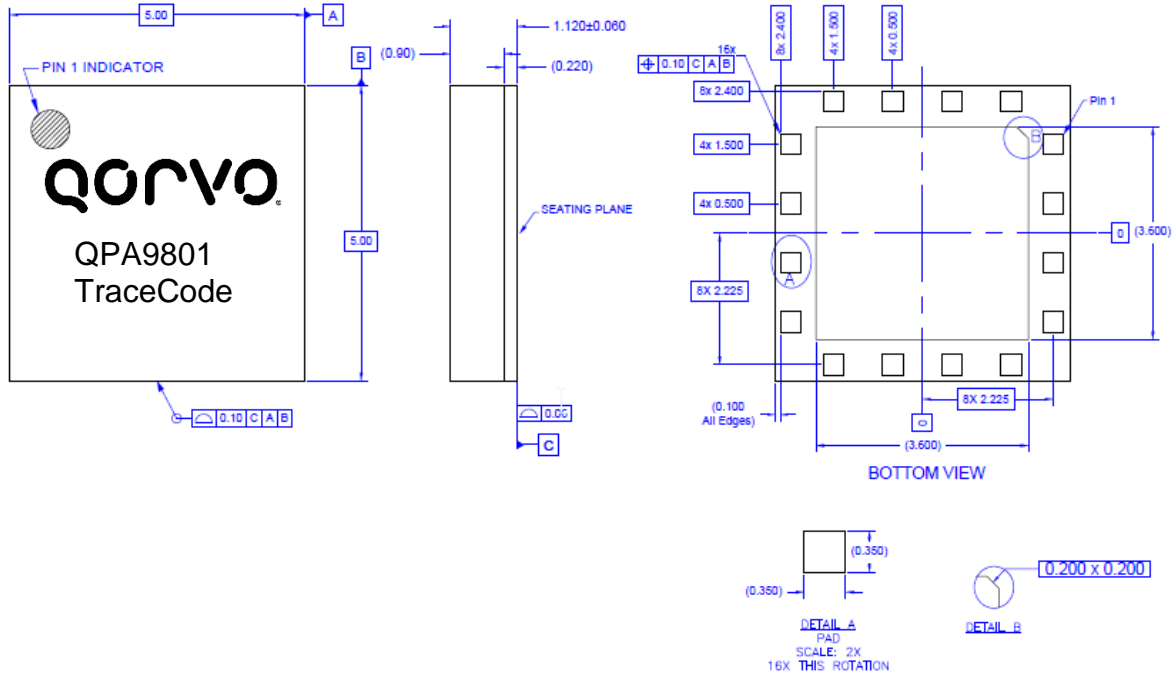

**Notes:**

1. All dimensions are in millimeters. Angles are in degrees.
2. The terminal #1 identifier and terminal numbering conform to JESD 95-1 SPP-012.
3. Contact plating: Au over Ni

### PCB Mounting Pattern

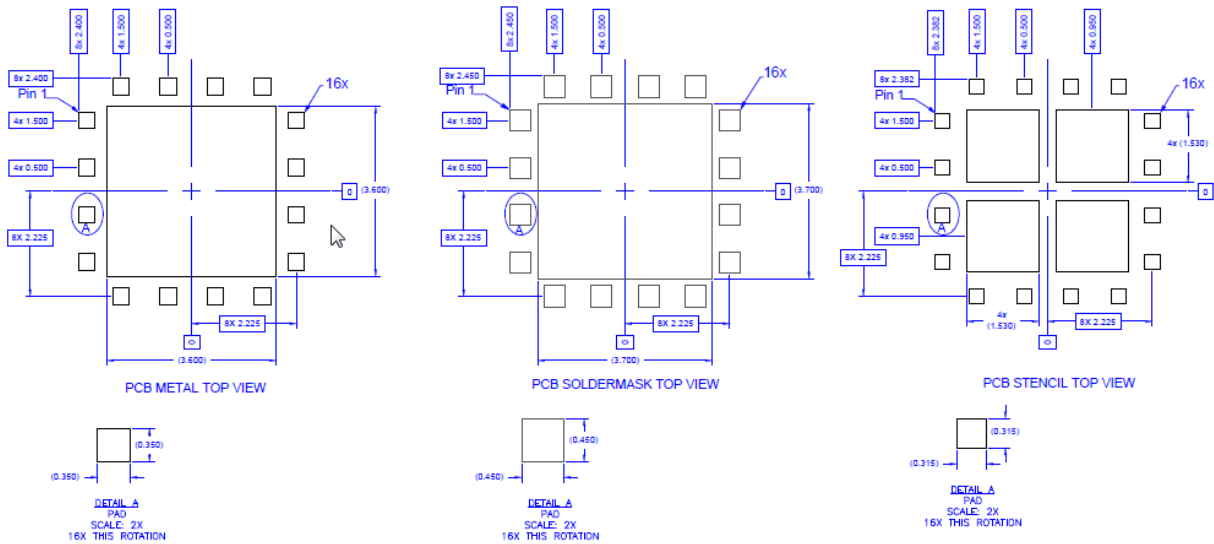

**Notes:**

1. All dimensions are in millimeters. Angles are in degrees.
2. Use 1 oz. copper minimum for top and bottom layer metal.
3. Vias are required under the backside paddle of this device for proper RF/DC grounding and thermal dissipation. We recommend a 0.35mm (#80/.0135") diameter bit for drilling via holes and a final plated thru diameter of 0.25 mm (0.10").
4. Ensure good package backside paddle solder attach for reliable operation and best electrical performance.

### Handling Precautions

Parameter	Rating	Standard
ESD – Human Body Model (HBM)	Class 1A	ESDA / JEDEC JS-001-2012
ESD – Charged Device Model (CDM)	Class C3	JEDEC JESD22-C101F
MSL – Moisture Sensitivity Level	Level 3	IPC/JEDEC J-STD-020



Caution!  
ESD-Sensitive Device

### Solderability

Compatible with both lead-free (260°C max. reflow temp.) and tin/lead (245°C max. reflow temp.) soldering processes.

Solder profiles available upon request.

Contact plating: Electrolytic plated Au over Ni

### RoHS Compliance

This part is compliant with EU 2002/95/EC RoHS directive (Restrictions on the Use of Certain Hazardous Substances in Electrical and Electronic Equipment). This product also has the following attributes:

- Product uses RoHS Exemption 7c-I to meet RoHS Compliance requirements
- Halogen Free (Chlorine, Bromine)
- Antimony Free
- TBBP-A (C<sub>15</sub>H<sub>12</sub>Br<sub>4</sub>O<sub>2</sub>) Free
- PFOS Free
- SVHC Free
- Qorvo Green



### Contact Information

For the latest specifications, additional product information, worldwide sales and distribution locations:

**Tel:** 1-844-890-8163

**Web:** [www.qorvo.com](http://www.qorvo.com)

**Email:** [customer.support@qorvo.com](mailto:customer.support@qorvo.com)

For technical questions and application information: **Email:** [appsupport@qorvo.com](mailto:appsupport@qorvo.com)

### Important Notice

The information contained herein is believed to be reliable; however, Qorvo makes no warranties regarding the information contained herein and assumes no responsibility or liability whatsoever for the use of the information contained herein. All information contained herein is subject to change without notice. Customers should obtain and verify the latest relevant information before placing orders for Qorvo products. The information contained herein or any use of such information does not grant, explicitly or implicitly, to any party any patent rights, licenses, or any other intellectual property rights, whether with regard to such information itself or anything described by such information. **THIS INFORMATION DOES NOT CONSTITUTE A WARRANTY WITH RESPECT TO THE PRODUCTS DESCRIBED HEREIN, AND QORVO HEREBY DISCLAIMS ANY AND ALL WARRANTIES WITH RESPECT TO SUCH PRODUCTS WHETHER EXPRESS OR IMPLIED BY LAW, COURSE OF DEALING, COURSE OF PERFORMANCE, USAGE OF TRADE OR OTHERWISE, INCLUDING THE IMPLIED WARRANTIES OF MERCHANTABILITY AND FITNESS FOR A PARTICULAR PURPOSE.**

Without limiting the generality of the foregoing, Qorvo products are not warranted or authorized for use as critical components in medical, life-saving, or life-sustaining applications, or other applications where a failure would reasonably be expected to cause severe personal injury or death.

Copyright 2017 © Qorvo, Inc. | Qorvo is a registered trademark of Qorvo, Inc.