

PART NAME: KNOB SCALE: 1:1 DATE: 12/17/93 DR. BY H.S.

THIS DRAWING IS THE PROPERTY OF DAVIES MOLDING COMPANY, IS SUBMITTED SOLELY AS A DESIGN OR ENGINEERING PROJECT. WE ACCEPT NO RESPONSIBILITY WHATSOEVER FOR THE PRACTICAL APPLICATION OF THE PIECES MADE TO THIS DESIGN.



DESIGNERS & MANUFACTURERS OF KNOBS, HANDLES, CASES & CUSTOM PLASTIC COMPONENTS

P/N 3035AM

M NO. 3035

PIN	3008-21
SHIMS	1/4
PLUNGER PIN	3035-A
INSERT	10012

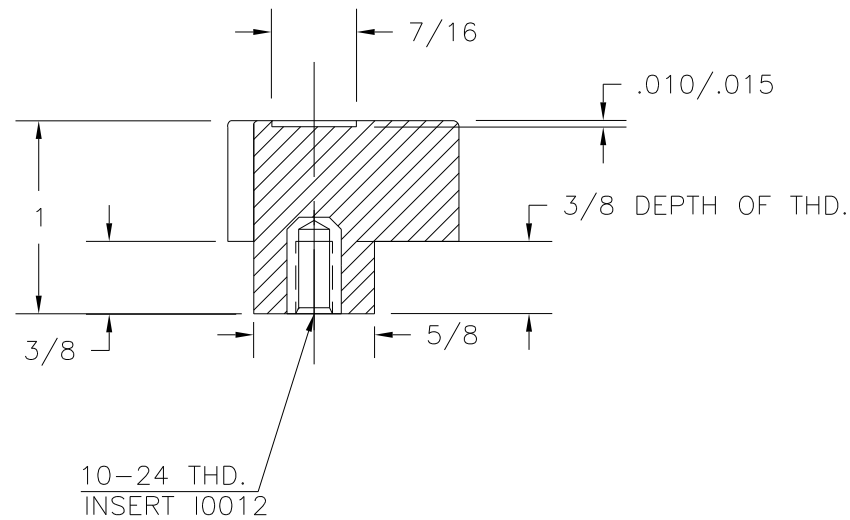
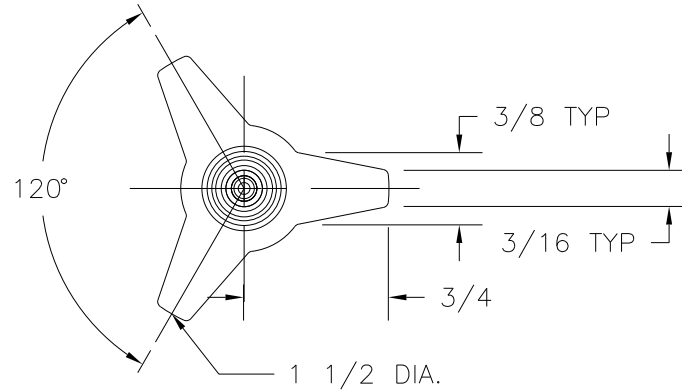

NOTE : ALL PARTS MUST BE CLEAN AND FREE OF ALL BURRS, CHIPS, AND OIL.

MATERIAL: G.P. PHENOLIC (B11)  
COLOR: BLACK

TOLERANCES: UNLESS OTHERWISE SPECIFIED	DO NOT SCALE DRAWING				
DECIMALS: X.XXX ± .005 X.XX ± .015	MM: X.XX ± 0.15MM X.X ± 0.4MM				
FRACTIONS ± 1/64	ANG. ± 1°	CHANGES			