

REVISIONS					
P	LTR	DESCRIPTION	DATE	DMN	APVD
S	REV PER ECO	17-000132	5-5-17	CT	DM

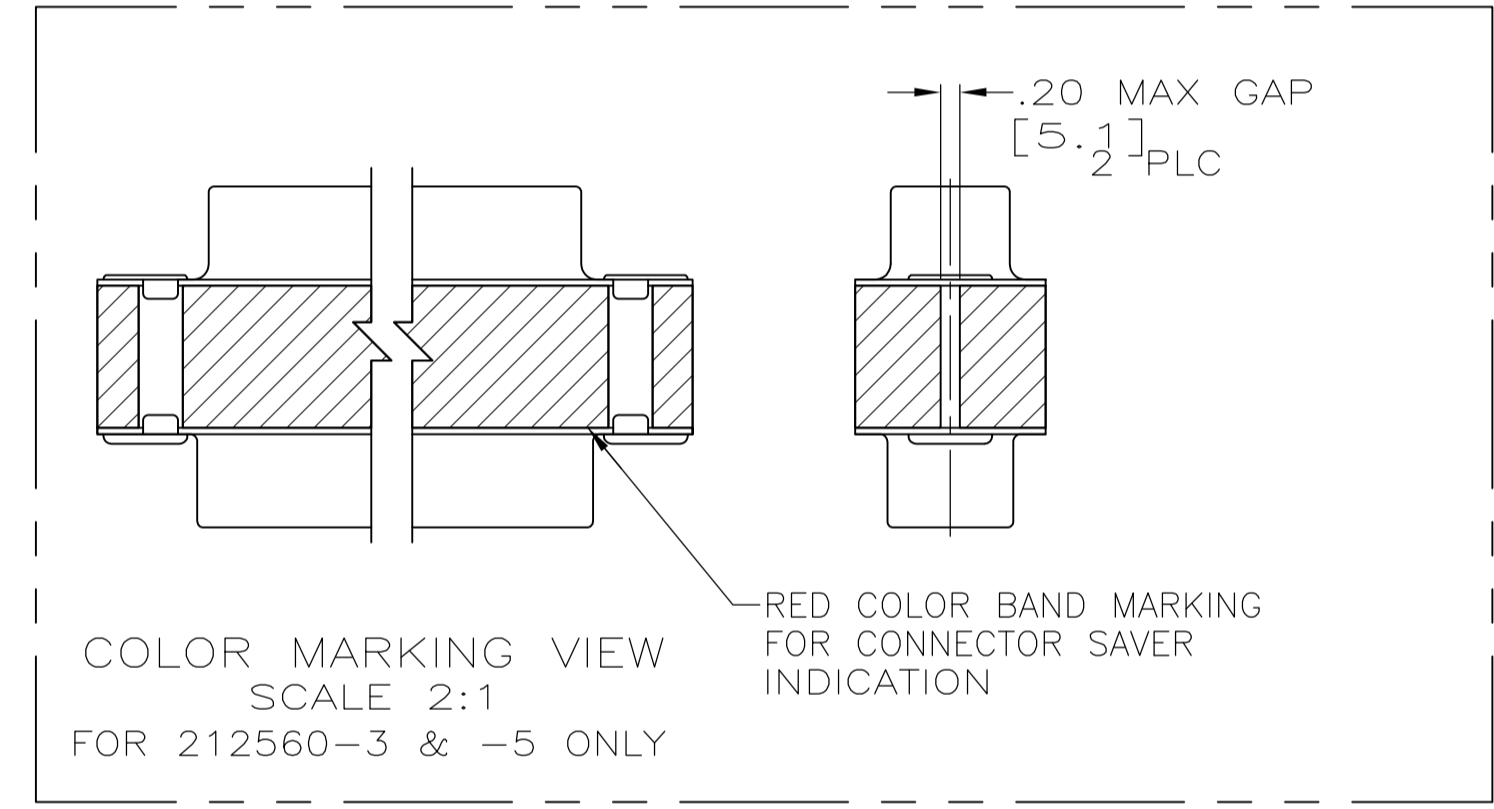
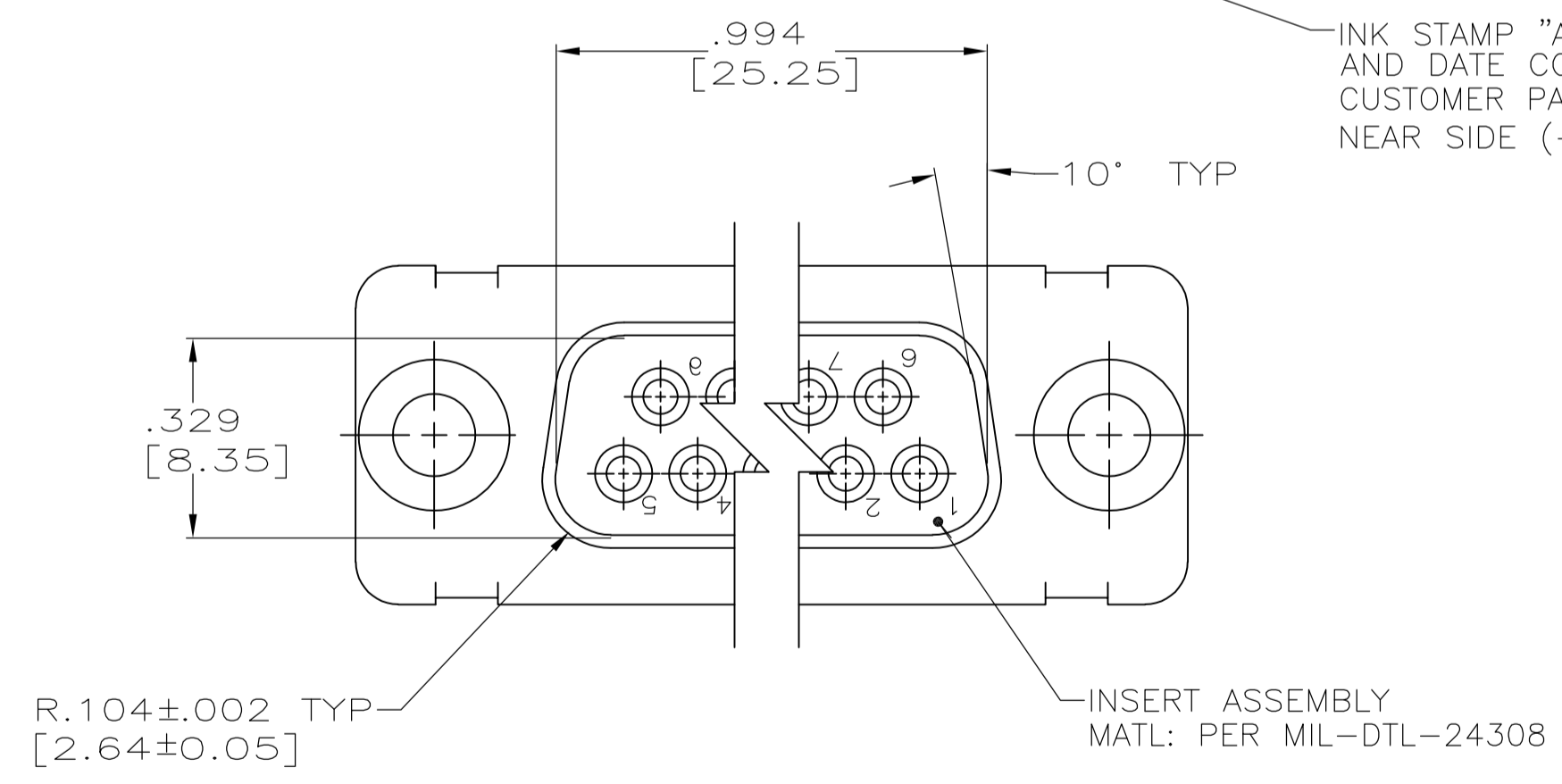
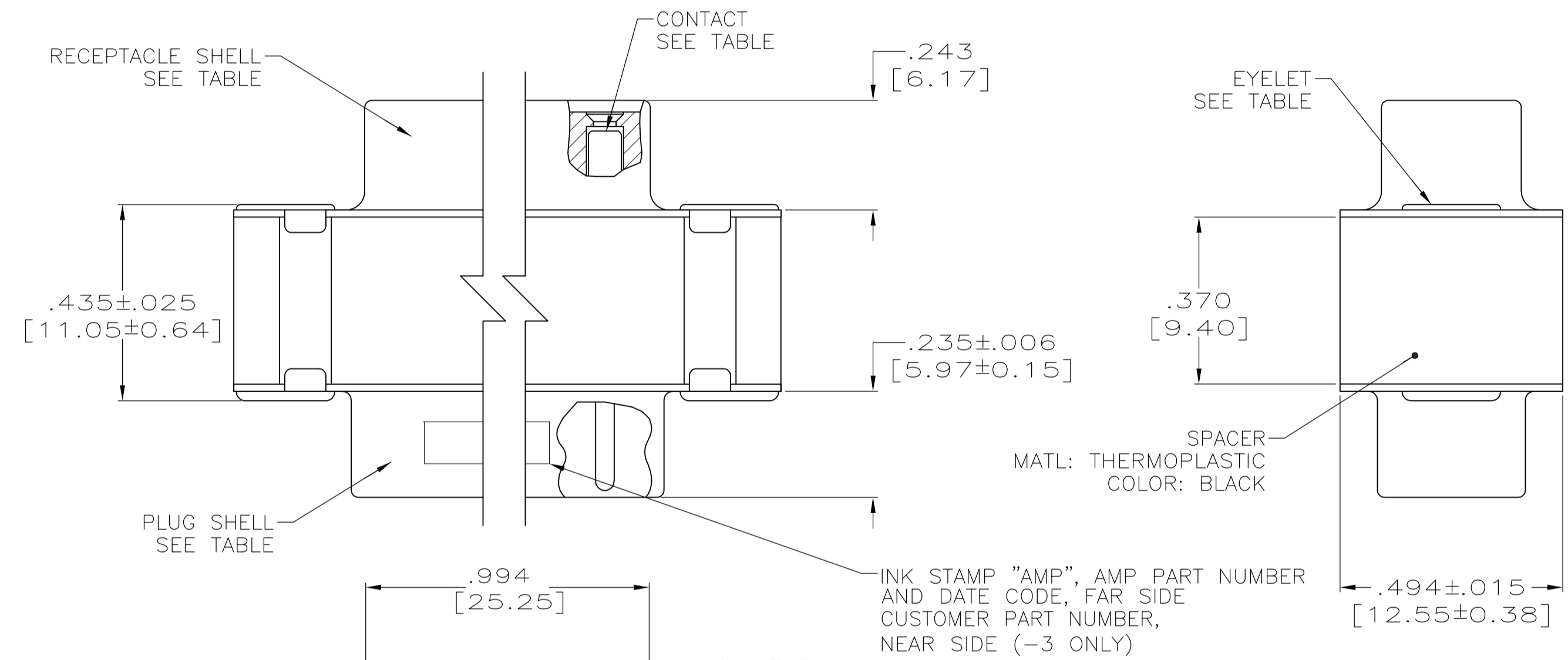
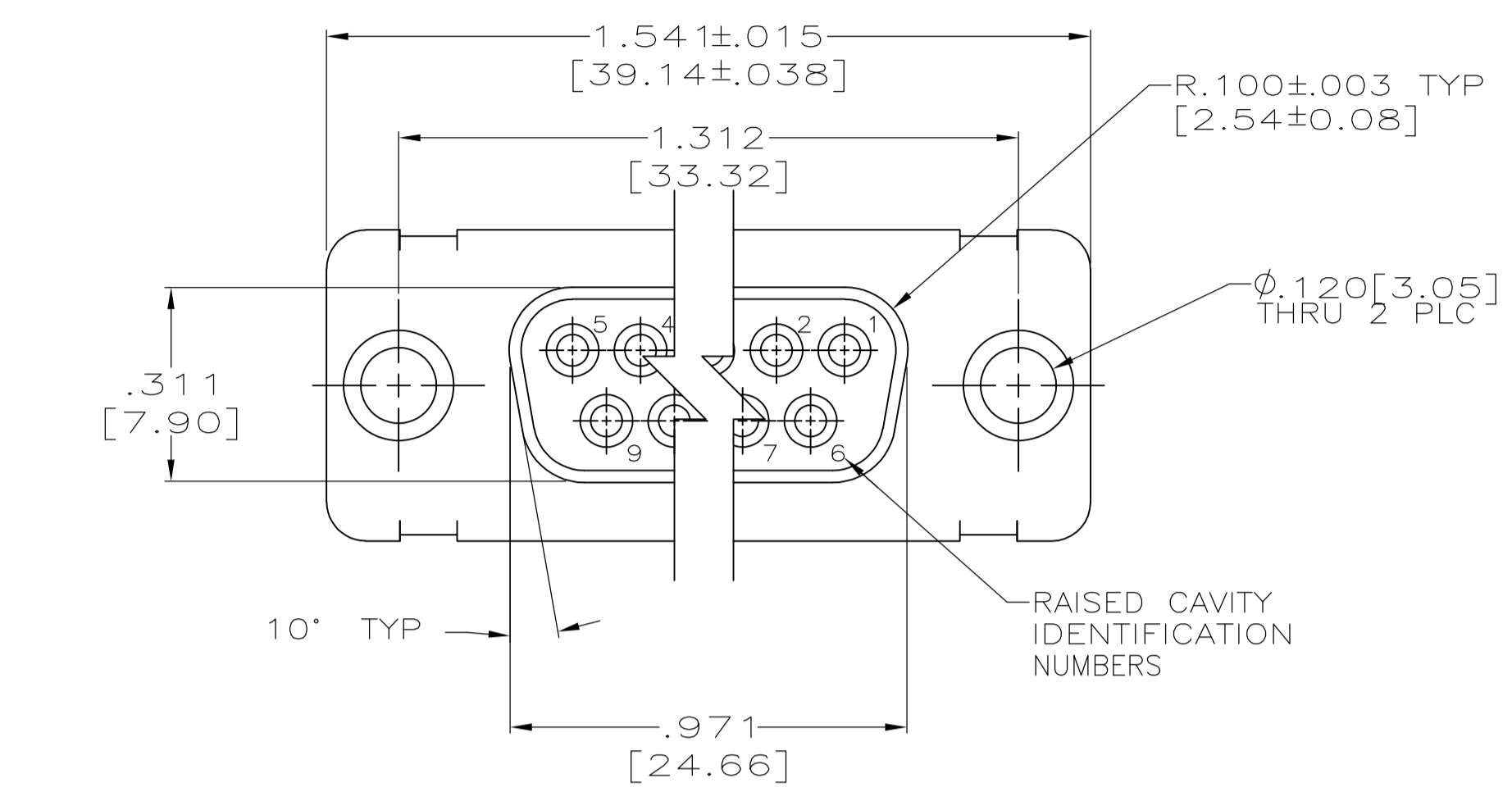

- 1. CONTACTS INCLUDED IN ASSEMBLY.
- △ MATL: STEEL, PER ASTM-A-109.
- △ FINISH: CADMIUM PER QQ-P-416.
- △ CONTACT
- BODY MATL: BERYLLIUM COPPER PER ASTM-B-197.
- BODY FINISH: PLATED GOLD, .000050 MIN THK PER MIL-G-45204 OVER NICKEL, .000050 MIN THK PER QQ-N-290.
- HOOD MATL: STAINLESS STEEL PER ASTM-A-167.
- HOOD FINISH: PASSIVATED PER ASTM-A-380.
- △ FINISH: PLATED ZINC .00020 MIN THK PER ASTM-B-633. YELLOW CHROMATE FINISH.
- △ MATL: BRASS PER ASTM-B-36.
- △ FINISH: PLATED GOLD, .000050 MIN THK PER MIL-G-45204 OVER COPPER, .000100 MIN THK PER MIL-C-14550.
- △ CONTACT
- BODY MATL: BERYLLIUM COPPER PER ASTM-B-197.
- BODY AND HOOD FINISH: PLATED GOLD, .000050 MIN THK PER MIL-G-45204 OVER COPPER, .000100 MIN THK PER MIL-C-14550.
- HOOD MATL: BRASS PER ASTM-B-36
- △ FINISH: PLATED ZINC PER ASTM-B-633 .000200 MIN THK WITH SUPPLEMENTARY CHROMATE (Cr2+).

EYELET	SHELLS	CONTACT	CUSTOMER P/N	PART NO.
△ △	△ △	△	-	5-212560-1
△ △	△ △	△	PT2-111-8	1-212560-2
△ △	△ △	△	4U884 SOCN R10002677-0102	212560-5
△ △	△ △	△	-	212560-4
△ △	△ △	△	(1J02-102)	212560-3
△ △	△ △	△	-	212560-2
△ △	△ △	△	-	212560-1

THIS DRAWING IS A CONTROLLED DOCUMENT.

DIMENSIONS: INCHES	TOLERANCES UNLESS OTHERWISE SPECIFIED:	DIN T. THOMPSON 11-07-94	CHK D. MANTIONE 11-07-94	APVD D. MANTIONE 11-07-94	NAME
0 PLC ± -	1 PLC ± -	2 PLC ± -	3 PLC ± .005 [0.13]	4 PLC ± -	ANGLES ± -
MATERIAL	FINISH	WEIGHT	0	A1 00779	C=212560
CUSTOMER DRAWING			SCALE 4:1	SHEET 1 OF 1	REV S

STE TE Connectivity  
CONNECTOR SAVER, AMPLIMITE 15 POSITION, SIZE 2, SERIES 109