

CGH55015F2 / CGH55015P2

10 W, C-band, Unmatched, GaN HEMT

Cree's CGH55015F2/CGH55015P2 is a gallium nitride (GaN) high electron mobility transistor (HEMT) designed specifically for high efficiency, high gain and wide bandwidth capabilities, which makes the CGH55015F2/CGH55015P2 ideal for C-band pulsed or CW saturated amplifiers. The transistor is available in both screw-down, flange and solder-down, pill packages. Based on appropriate external match adjustment, the CGH55015F2/CGH55015P2 is suitable for applications up to 6 GHz.

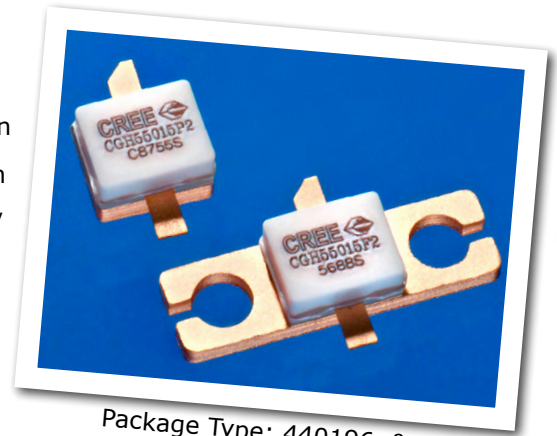

Package Type: 440196 & 440166
PN: CGH55015P2 & CGH55015F2

FEATURES

- 4.5 to 6.0 GHz Operation
- 12 dB Small Signal Gain at 5.65 GHz
- 13 W typical P_{SAT}
- 60 % Efficiency at P_{SAT}
- 28 V Operation

APPLICATIONS

- 2-Way Private Radio
- Broadband Amplifiers
- Cellular Infrastructure
- Test Instrumentation
- Class A, AB Amplifiers for Drivers and Gain Blocks



Large Signal Models Available for SiC & GaN



Absolute Maximum Ratings (not simultaneous) at 25 °C Case Temperature

Parameter	Symbol	Rating	Units	Conditions
Drain-Source Voltage	V_{DS}	84	Volts	25 °C
Gate-to-Source Voltage	V_{GS}	-10, +2	Volts	25 °C
Storage Temperature	T_{STG}	-65, +150	°C	
Operating Junction Temperature	T_J	225	°C	
Maximum Forward Gate Current	I_{GMAX}	4.0	mA	25 °C
Maximum Drain Current ¹	I_{DMAX}	1.5	A	25 °C
Soldering Temperature ²	T_S	245	°C	
Screw Torque	τ	60	in-oz	
Thermal Resistance, Junction to Case ³	$R_{\theta JC}$	8.0	°C/W	85 °C
Case Operating Temperature ^{3,4}	T_C	-40, +150	°C	30 seconds

Note:

¹ Current limit for long term, reliable operation.

² Refer to the Application Note on soldering at www.cree.com/products/wireless_appnotes.asp

³ Measured for the CGH55015 at $P_{DISS} = 14W$.

⁴ See also, the Power Dissipation De-rating Curve on Page 5.

Electrical Characteristics ($T_C = 25^\circ C$)

Characteristics	Symbol	Min.	Typ.	Max.	Units	Conditions
DC Characteristics¹						
Gate Threshold Voltage	$V_{GS(th)}$	-3.8	-3.0	-2.3	V_{DC}	$V_{DS} = 10 V, I_D = 3.6 mA$
Gate Quiescent Voltage	$V_{GS(Q)}$	-	-2.7	-	V_{DC}	$V_{DS} = 28 V, I_D = 200 mA$
Saturated Drain Current	I_{DS}	2.9	3.5	-	A	$V_{DS} = 6.0 V, V_{GS} = 2.0 V$
Drain-Source Breakdown Voltage	V_{BR}	120	-	-	V_{DC}	$V_{GS} = -8 V, I_D = 3.6 mA$
RF Characteristics² ($T_C = 25^\circ C, F_0 = 5.65 GHz$ unless otherwise noted)						
Small Signal Gain	G_{SS}	10	12	-	dB	$V_{DD} = 28 V, I_{DQ} = 200 mA$
Power Output ³	P_{SAT}	10	12.5	-	W	$V_{DD} = 28 V, I_{DQ} = 200 mA$
Drain Efficiency ⁴	η	50	60	-	%	$V_{DD} = 28 V, I_{DQ} = 200 mA, P_{OUT} = 10 W$
Output Mismatch Stress	VSWR	-	-	10 : 1	Ψ	No damage at all phase angles, $V_{DD} = 28 V, I_{DQ} = 200 mA,$ $P_{OUT} = 10 W CW$
Dynamic Characteristics						
Input Capacitance	C_{GS}	-	4.5	-	pF	$V_{DS} = 28 V, V_{gs} = -8 V, f = 1 MHz$
Output Capacitance	C_{DS}	-	1.3	-	pF	$V_{DS} = 28 V, V_{gs} = -8 V, f = 1 MHz$
Feedback Capacitance	C_{GD}	-	0.2	-	pF	$V_{DS} = 28 V, V_{gs} = -8 V, f = 1 MHz$

Notes:

¹ Measured on wafer prior to packaging.

² Measured in CGH55015-TB.

³ P_{SAT} is defined as $I_G = 0.36 mA$.

⁴ Drain Efficiency = P_{OUT} / P_{DC}

Typical Performance

**Small Signal S-Parameters vs Frequency of
CGH55015F2 and CGH55015P2 in the CGH55015-TB**
 $V_{DD} = 28\text{ V}, I_{DQ} = 200\text{ mA}$

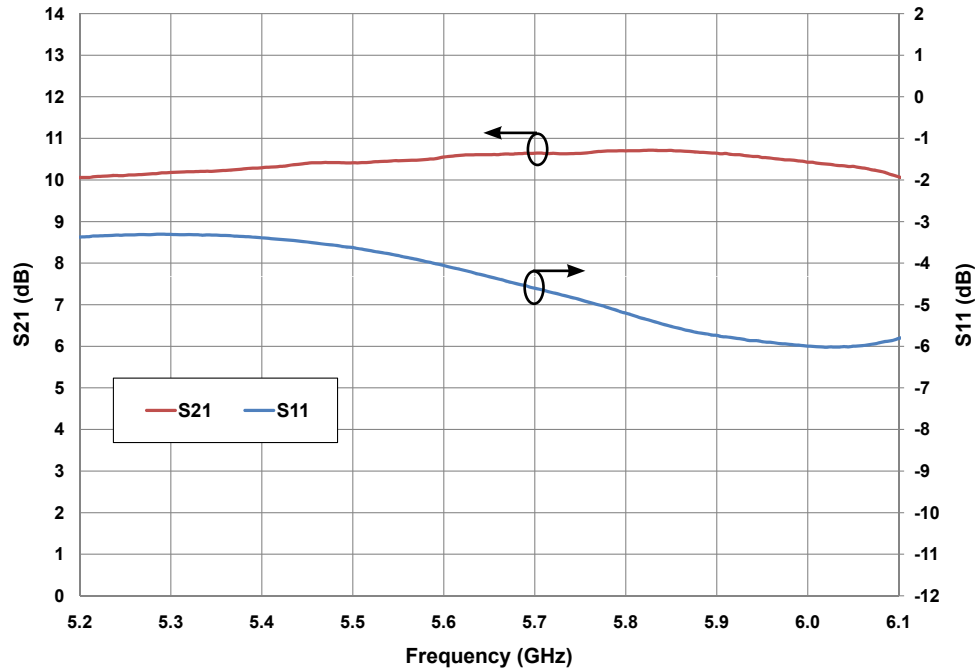

**Drain Efficiency, Power and Gain vs Frequency of the
CGH55015F2 and CGH55015P2 in the CGH55015-TB**
 $V_{DD} = 28\text{ V}, I_{DQ} = 200\text{ mA}$

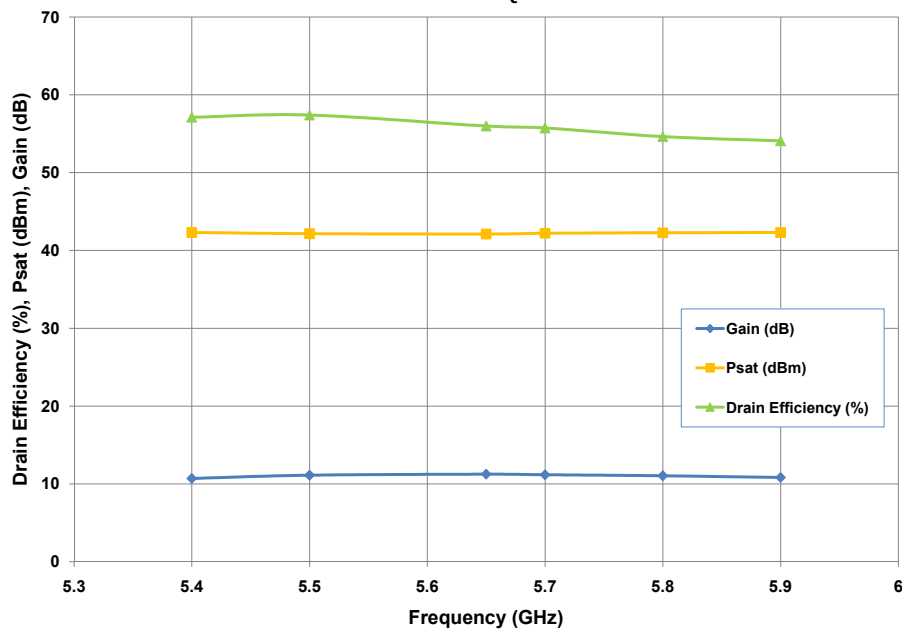



Typical Performance

Simulated Maximum Available Gain and K Factor of the CGH55015F2/CGH55015P2
 $V_{DD} = 28\text{ V}, I_{DQ} = 200\text{ mA}$

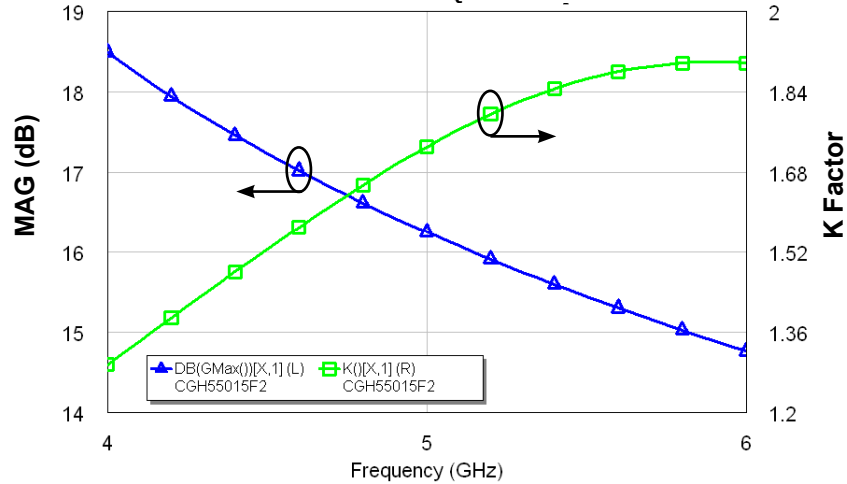

Typical Noise Performance

Simulated Minimum Noise Figure and Noise Resistance vs Frequency of the CGH55015F2/CGH55015P2
 $V_{DD} = 28\text{ V}, I_{DQ} = 200\text{ mA}$

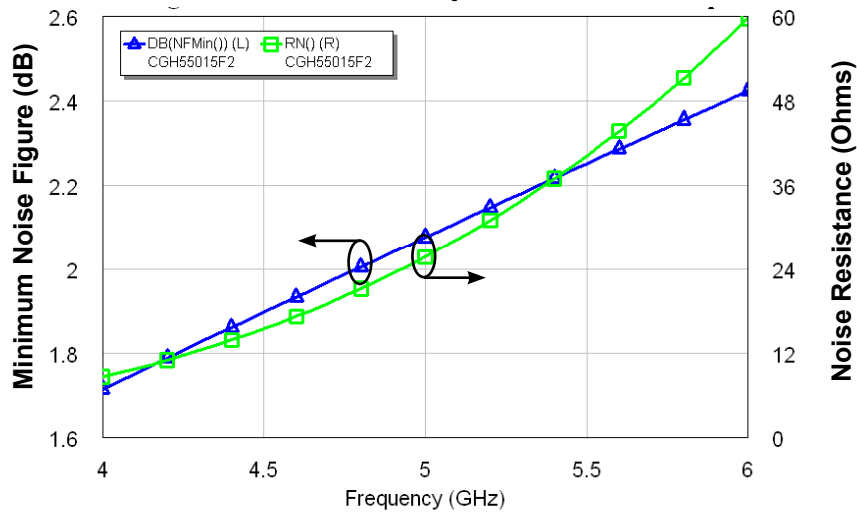

Electrostatic Discharge (ESD) Classifications

Parameter	Symbol	Class	Test Methodology
Human Body Model	HBM	1A > 250 V	JEDEC JESD22 A114-D
Charge Device Model	CDM	1 < 200 V	JEDEC JESD22 C101-C

Source and Load Impedances

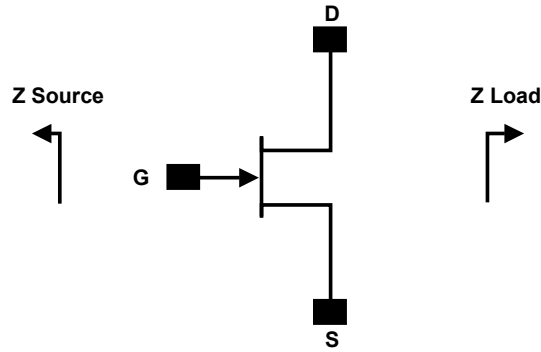

Frequency (MHz)	Z Source	Z Load
5500	8.7 - j30.2	21.6 - j4.7
5650	10.2 - j26.9	24.2 - j5.5
5800	12.3 - j24.3	26.5 - j7.5

Note 1. $V_{DD} = 28V$, $I_{DQ} = 200\text{ mA}$ in the 440166 package.

Note 2. Impedances are extracted from the CGH55015-TB demonstration amplifier and are not source and load pull data derived from the transistor.

CGH55015F2 and CGH55015P2 Power Dissipation De-rating Curve

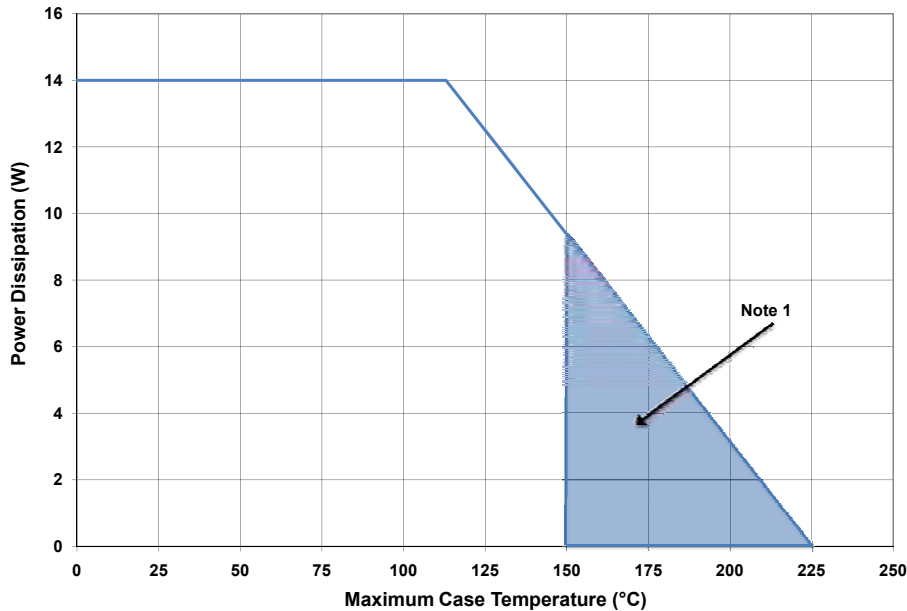

Note 1. Area exceeds Maximum Case Operating Temperature (See Page 2).

CGH55015-TB Demonstration Amplifier Circuit Bill of Materials

Designator	Description	Qty
C1	CAP, 1.2pF, +/-0.1 pF, 0603, ATC 600S	1
C2	CAP, 0.3pF, +/-0.05 pF, 0402, ATC 600L	1
C9	CAP, 0.5pF, +/-0.05pF, 0603, ATC 600S	1
C4,C11	CAP, 18pF, +/-5%, 0603, ATC 600S	2
C5,C12	CAP, 39pF +/-5%, 0603, ATC 600S	2
C6,C13	CAP, CER, 180pF, 50V, +/-5%, COG, 0603	2
C7,C14	CAP, CER, 0.1UF, 50V, +/-10%, X7R, 0805	2
C8	CAP, 10UF, 16V, SMT, TANTALUM	1
C15	CAP, 1.0UF ±10%, 100V, 1210, X7R	1
C16	CAP, 33UF, 100V, ELECT, FK, SMD	1
R1	RES, 1/16W, 0603, 1%, 562 OHMS	1
R2	RES, 1/16W, 0603, 1%, 22 OHMS	1
J1	HEADER RT> PLZ .1 CEN LK 5 POS	1
J3,J4	CONN, SMA, FLANGE	2
-	PCB, RO4350B, Er = 3.48, h = 20 mil	1
-	CGH55015	1

CGH55015-TB Demonstration Amplifier Circuit

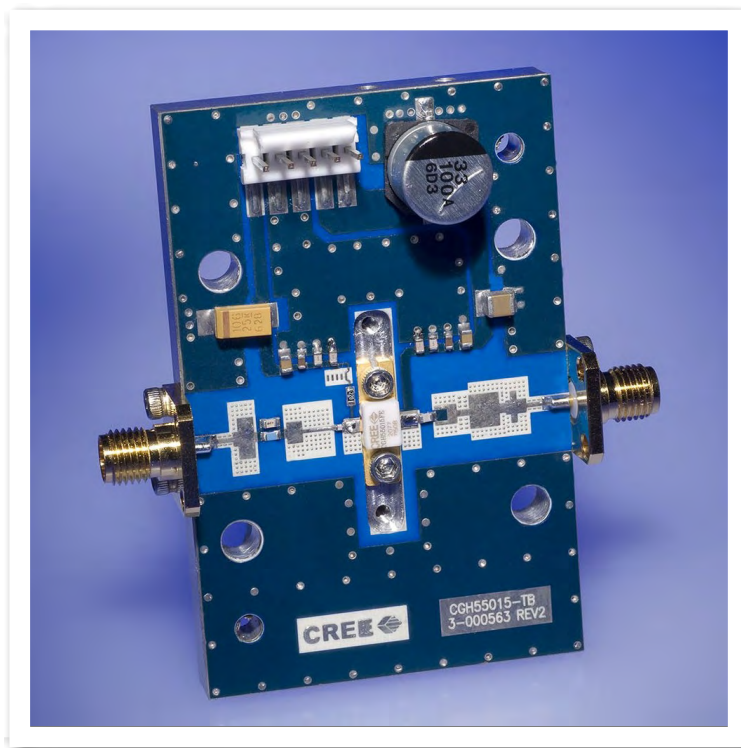

CGH55015-TB Demonstration Amplifier Circuit Schematic

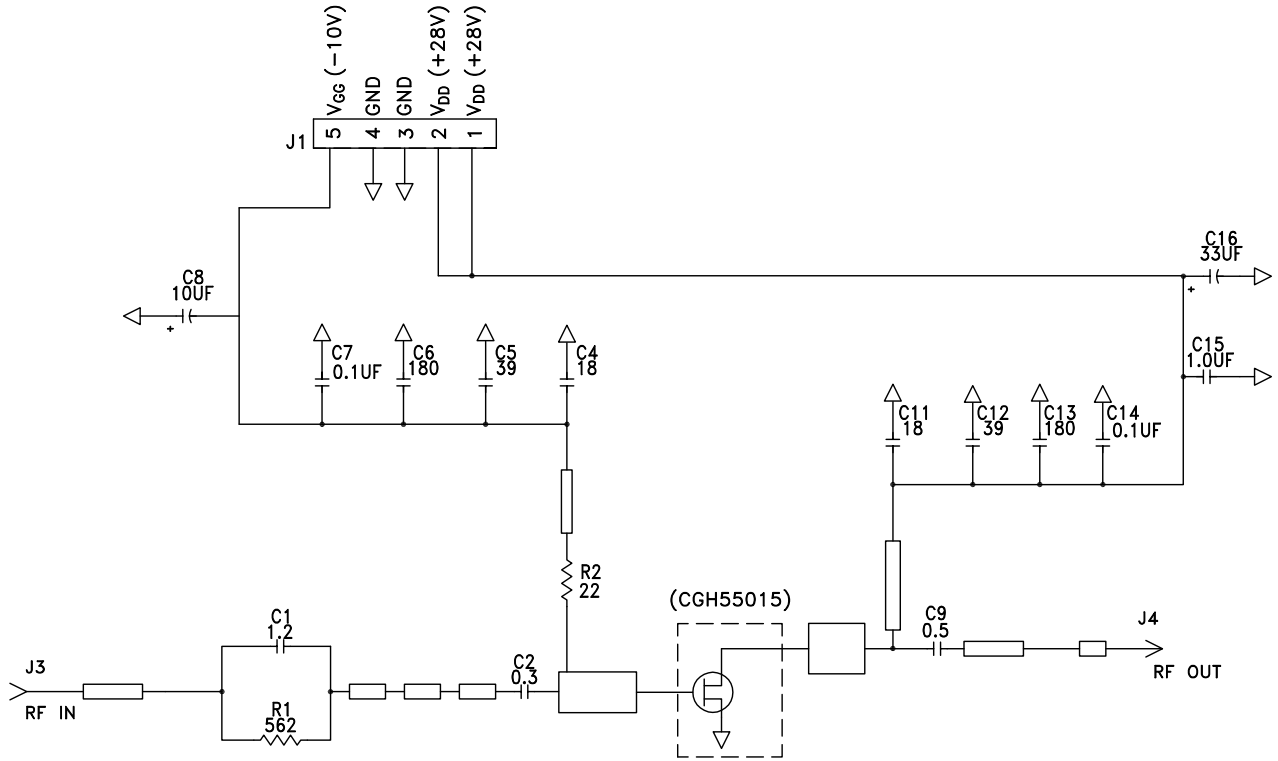

CGH55015-TB Demonstration Amplifier Circuit Outline

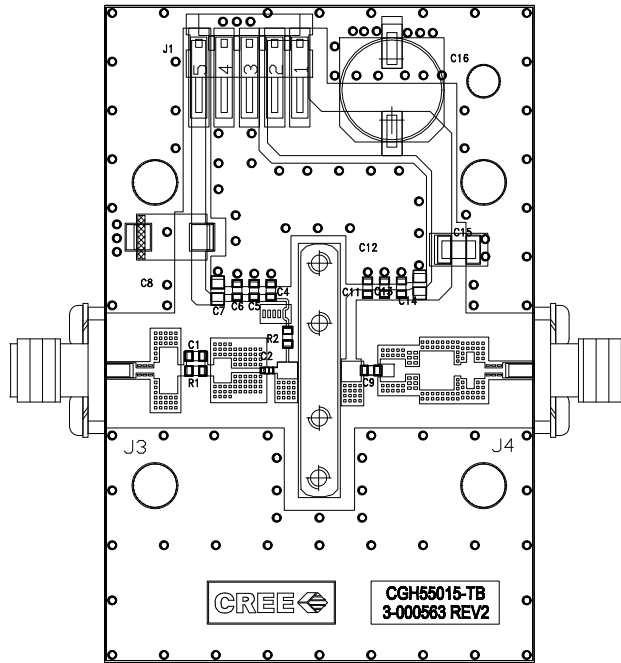



Typical Package S-Parameters for CGH55015F2 / CGH55015P2
 (Small Signal, $V_{DS} = 28\text{ V}$, $I_{DQ} = 200\text{ mA}$, angle in degrees)

Frequency	Mag S11	Ang S11	Mag S21	Ang S21	Mag S12	Ang S12	Mag S22	Ang S22
500 MHz	0.911	-130.86	18.44	105.32	0.022	19.38	0.302	-113.00
600 MHz	0.906	-139.86	15.82	99.40	0.023	14.28	0.299	-120.56
700 MHz	0.902	-146.89	13.81	94.44	0.023	10.15	0.298	-126.20
800 MHz	0.900	-152.58	12.23	90.14	0.023	6.68	0.299	-130.51
900 MHz	0.898	-157.33	10.97	86.29	0.023	3.69	0.302	-133.91
1.0 GHz	0.897	-161.38	9.93	82.79	0.023	1.03	0.305	-136.65
1.1 GHz	0.896	-164.92	9.06	79.53	0.023	-1.36	0.309	-138.93
1.2 GHz	0.895	-168.07	8.33	76.47	0.023	-3.55	0.314	-140.86
1.3 GHz	0.895	-170.92	7.71	73.56	0.023	-5.58	0.320	-142.55
1.4 GHz	0.895	-173.52	7.17	70.77	0.023	-7.47	0.326	-144.06
1.5 GHz	0.894	-175.93	6.70	68.08	0.023	-9.25	0.332	-145.44
1.6 GHz	0.894	-178.19	6.29	65.47	0.023	-10.93	0.338	-146.73
1.7 GHz	0.894	179.68	5.92	62.93	0.023	-12.52	0.345	-147.96
1.8 GHz	0.894	177.66	5.60	60.44	0.023	-14.04	0.351	-149.13
1.9 GHz	0.894	175.72	5.31	58.01	0.022	-15.49	0.358	-150.28
2.0 GHz	0.894	173.85	5.04	55.62	0.022	-16.88	0.365	-151.42
2.1 GHz	0.895	172.04	4.80	53.26	0.022	-18.21	0.372	-152.54
2.2 GHz	0.895	170.28	4.59	50.93	0.022	-19.48	0.379	-153.66
2.3 GHz	0.895	168.57	4.39	48.64	0.022	-20.69	0.386	-154.78
2.4 GHz	0.895	166.88	4.21	46.37	0.021	-21.85	0.393	-155.92
2.5 GHz	0.895	165.22	4.04	44.11	0.021	-22.96	0.400	-157.06
2.6 GHz	0.895	163.58	3.88	41.88	0.021	-24.02	0.407	-158.21
2.7 GHz	0.895	161.97	3.74	39.67	0.021	-25.02	0.413	-159.37
2.8 GHz	0.896	160.36	3.61	37.47	0.020	-25.97	0.420	-160.55
2.9 GHz	0.896	158.76	3.49	35.28	0.020	-26.87	0.426	-161.75
3.0 GHz	0.896	157.17	3.37	33.11	0.020	-27.72	0.433	-162.96
3.2 GHz	0.896	153.99	3.17	28.79	0.019	-29.24	0.445	-165.43
3.4 GHz	0.896	150.81	2.99	24.49	0.019	-30.53	0.456	-167.97
3.6 GHz	0.897	147.59	2.83	20.21	0.018	-31.57	0.467	-170.58
3.8 GHz	0.897	144.34	2.69	15.94	0.018	-32.35	0.477	-173.26
4.0 GHz	0.897	141.03	2.56	11.67	0.017	-32.86	0.487	-176.01
4.2 GHz	0.897	137.66	2.45	7.39	0.017	-33.08	0.496	-178.84
4.4 GHz	0.897	134.20	2.35	3.09	0.017	-33.02	0.504	178.25
4.6 GHz	0.897	130.65	2.26	-1.24	0.016	-32.67	0.511	175.25
4.8 GHz	0.897	127.01	2.18	-5.61	0.016	-32.06	0.517	172.16
5.0 GHz	0.896	123.25	2.11	-10.03	0.016	-31.23	0.523	168.97
5.2 GHz	0.896	119.37	2.04	-14.50	0.016	-30.22	0.528	165.68
5.4 GHz	0.896	115.36	1.98	-19.04	0.016	-29.11	0.532	162.26
5.6 GHz	0.896	111.21	1.92	-23.65	0.016	-27.99	0.536	158.72
5.8 GHz	0.895	106.92	1.87	-28.34	0.017	-26.98	0.539	155.04
6.0 GHz	0.895	102.47	1.83	-33.12	0.017	-26.15	0.541	151.21

Download this s-parameter file in ".s2p" format at http://www.cree.com/products/wireless_s-parameters.asp

Product Dimensions CGH55015F2 (Package Type — 440166)

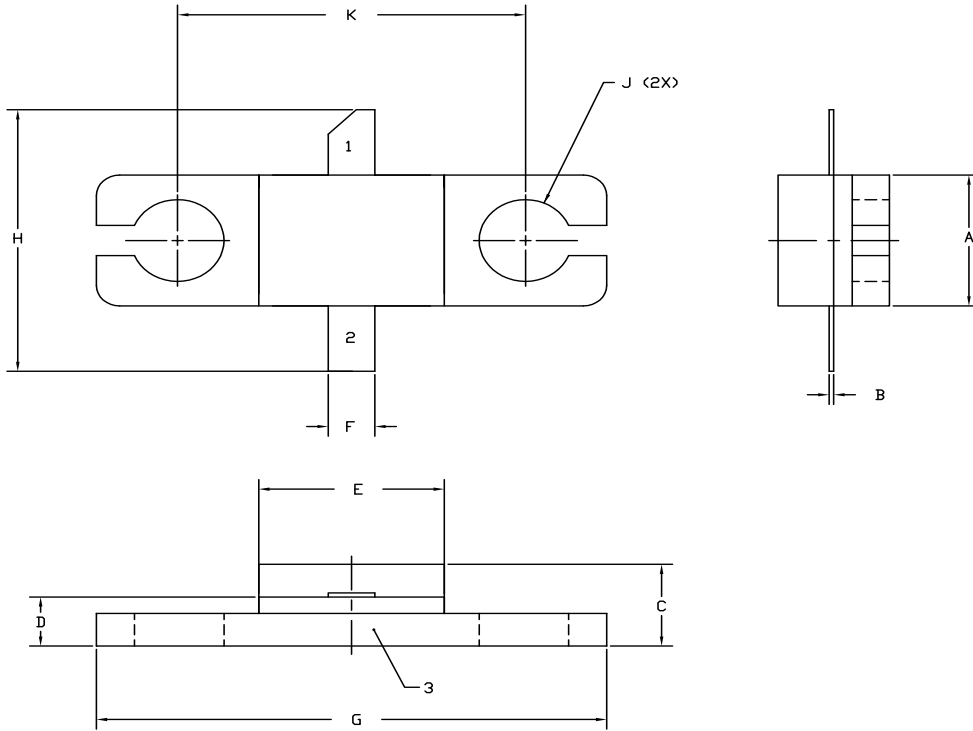

NOTES:

1. DIMENSIONING AND TOLERANCING PER ANSI Y14.5M, 1982.
2. CONTROLLING DIMENSION: INCH.
3. ADHESIVE FROM LID MAY EXTEND A MAXIMUM OF 0.020" BEYOND EDGE OF LID.
4. LID MAY BE MISALIGNED TO THE BODY OF THE PACKAGE BY A MAXIMUM OF 0.008" IN ANY DIRECTION.
5. ALL PLATED SURFACES ARE NI/AU

DIM	INCHES		MILLIMETERS	
	MIN	MAX	MIN	MAX
A	0.155	0.165	3.94	4.19
B	0.004	0.006	0.10	0.15
C	0.115	0.135	2.92	3.43
D	0.057	0.067	1.45	1.70
E	0.195	0.205	4.95	5.21
F	0.045	0.055	1.14	1.40
G	0.545	0.555	13.84	14.09
H	0.280	0.360	7.11	9.14
J	∅ .100		2.54	
K	0.375		9.53	

- PIN 1. GATE
 PIN 2. DRAIN
 PIN 3. SOURCE

Product Dimensions CGH55015P2 (Package Type — 440196)

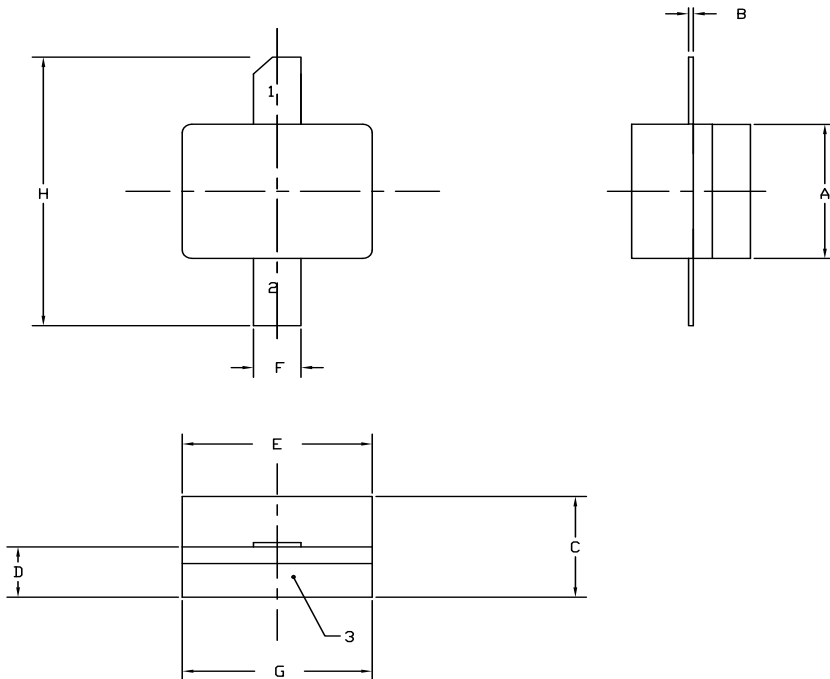

NOTES:

1. DIMENSIONING AND TOLERANCING PER ANSI Y14.5M, 1982.
2. CONTROLLING DIMENSION: INCH.
3. ADHESIVE FROM LID MAY EXTEND A MAXIMUM OF 0.020" BEYOND EDGE OF LID.
4. LID MAY BE MISALIGNED TO THE BODY OF THE PACKAGE BY A MAXIMUM OF 0.008" IN ANY DIRECTION.
5. ALL PLATED SURFACES ARE NI/AU

DIM	INCHES		MILLIMETERS	
	MIN	MAX	MIN	MAX
A	0.155	0.165	3.94	4.19
B	0.003	0.006	0.10	0.15
C	0.115	0.135	2.92	3.17
D	0.057	0.067	1.45	1.70
E	0.195	0.205	4.95	5.21
F	0.045	0.055	1.14	1.40
G	0.195	0.205	4.95	5.21
H	0.280	0.360	7.11	9.14

- PIN 1. GATE
 PIN 2. DRAIN
 PIN 3. SOURCE



Disclaimer

Specifications are subject to change without notice. Cree, Inc. believes the information contained within this data sheet to be accurate and reliable. However, no responsibility is assumed by Cree for any infringement of patents or other rights of third parties which may result from its use. No license is granted by implication or otherwise under any patent or patent rights of Cree. Cree makes no warranty, representation or guarantee regarding the suitability of its products for any particular purpose. "Typical" parameters are the average values expected by Cree in large quantities and are provided for information purposes only. These values can and do vary in different applications and actual performance can vary over time. All operating parameters should be validated by customer's technical experts for each application. Cree products are not designed, intended or authorized for use as components in applications intended for surgical implant into the body or to support or sustain life, in applications in which the failure of the Cree product could result in personal injury or death or in applications for planning, construction, maintenance or direct operation of a nuclear facility.

For more information, please contact:

Cree, Inc.
4600 Silicon Drive
Durham, North Carolina, USA 27703
www.cree.com/wireless

Sarah Miller
Marketing & Export
Cree, RF Components
1.919.407.5302

Ryan Baker
Marketing
Cree, Wireless Devices
1.919.287.7816

Tom Dekker
Sales Director
Cree, Wireless Devices
1.919.313.5639