



NUMBER GS-12-650	TYPE PRODUCT SPECIFICATION		
TITLE Mini-SAS HD Internal Cable to Board Connector System		PAGE 1 of 1	REVISION A
		AUTHORIZED BY David Lord	DATE 2012-10-11
		CLASSIFICATION UNRESTRICTED	

TABLE OF CONTENTS

1.0	OBJECTIVE	2
2.0	SCOPE	2
3.0	APPLICABLE DOCUMENTS	2
4.0	RATINGS	2
5.0	GENERAL REQUIREMENTS	3
5.1	MATERIALS, PLATING, AND PRODUCT MARKINGS	3
5.2	VISUAL EXAMINATION OF PRODUCT	3
6.0	ELECTRICAL REQUIREMENTS	3
6.1	LOW LEVEL CONTACT RESISTANCE (LLCR)	3
6.2	INSULATION RESISTANCE (IR)	3
6.3	DIELECTRIC WITHSTANDING VOLTAGE (DWV)	3
6.4	CURRENT RATING (VIA CURRENT CYCLING)	3
6.5	DIFFERENTIAL IMPEDANCE	3
7.0	MECHANICAL REQUIREMENTS	4
7.1	MATING / UN-MATING FORCES (LATCH DISENGAGED)	4
7.2	LATCH MATING FORCE	4
7.3	CABLE PLUG PULL-OUT FORCE (LATCH ENGAGED)	4
7.4	CABLE STRAIN RELIEF (UN-MATED)	4
7.5	WIRE FLEX	4
7.6	CABLE MINIMUM BEND RADIUS	4
7.7	PRESS-FIT INSERTION FORCES	4
7.8	PRESS-FIT WITHDRAWAL FORCES	4
7.9	CONNECTOR LONGITUDINAL LOADING	4
7.10	CONNECTOR LATITUDINAL LOADING	4
7.11	DURABILITY	5
7.12	PRE-CONDITIONING	6
7.13	SCREW TORQUE	6
8.0	ENVIRONMENTAL REQUIREMENTS	6
8.1	TEMPERATURE LIFE	6
8.2	TEMPERATURE LIFE PRECONDITIONING	6
8.3	THERMAL SHOCK	6
8.4	CYCLICAL HUMIDITY AND TEMPERATURE	6
8.5	MECHANICAL VIBRATION	7
8.6	MECHANICAL SHOCK	7
8.7	MIXED FLOWING GAS (MFG)	7
8.8	THERMAL DISTURBANCE	7
8.9	RESEAT	7
9.0	QUALITY ASSURANCE PROVISIONS	7
10.0	REVISION RECORD	11

NUMBER GS-12-650	TYPE PRODUCT SPECIFICATION		
TITLE Mini-SAS HD Internal Cable to Board Connector System		PAGE 2 of 2	REVISION A
		AUTHORIZED BY David Lord	DATE 2012-10-11
		CLASSIFICATION UNRESTRICTED	

1.0 OBJECTIVE

This specification defines the quality and reliability, performance, and test requirements of the Mini-SAS HD internal connector system. This specification applies to the 1X1, 1X2, and 1X4 size configurations.

2.0 SCOPE

This specification is applicable to the Mini-SAS HD internal connector system which provides a high speed cable to board interconnect.

3.0 APPLICABLE DOCUMENTS

3.1 FCI Specifications

- Applicable FCI product customer drawings
- GS-20-0356: FCI Application Specification, Mini-SAS HD internal connector system
- GS-14-1490: FCI Packaging Specification, Mini-SAS HD internal connector system
- GS-14-1272: FCI High Speed Cables Packaging Specification

3.2 Other Standards and Specifications

- UL94V-0: Test for Flammability of Plastic Materials in Devices and Appliances
- EIA 364: Electrical Connector/Socket Test Procedures Including Environmental Classifications

3.3 FCI Product Qualification Test reports

- EL 2012-06-024D-CR-PE-001: Mini-SAS HD Internal Connector System Engineering Test Report

3.4 Safety Agency Approvals

- UL File Number: E66906

4.0 RATINGS

4.1 Voltage

- 30 Volts AC (RMS) / DC Maximum

4.2 Current

- 0.5 Amps Maximum

4.3 Temperature

- Operating: -40°C to +80°C
- Non-operating: -55°C to +80°C

NUMBER GS-12-650	TYPE PRODUCT SPECIFICATION		
TITLE Mini-SAS HD Internal Cable to Board Connector System		PAGE 3 of 3	REVISION A
		AUTHORIZED BY David Lord	DATE 2012-10-11
		CLASSIFICATION UNRESTRICTED	

5.0 GENERAL REQUIREMENTS

5.1 **Materials, Plating, and Product Markings**

Refer to the appropriate customer drawing for the materials, plating, and product markings.

5.2 **Visual Examination of Product**

Visual examinations shall be performed using 10X magnification. Parts should be free from blistering, cracks, etc.

6.0 ELECTRICAL REQUIREMENTS

6.1 **Low Level Contact Resistance (LLCR)**

Measurements shall be performed per EIA 364-23. The maximum change in low level contact resistance, from the initial measurement, shall be less than 10 milliohms. The following details apply:

- Test Voltage: 20mV maximum
- Test Current: 100mA maximum

6.2 **Insulation Resistance (IR)**

The insulation resistance of mated connectors shall not be less than 1000 MΩ after environmental exposure when measured in accordance with EIA 364-21. The following details shall apply:

- Test voltage: 300 VDC
- Electrification time: 60 seconds
- Points of measurement: between adjacent contacts

6.3 **Dielectric Withstanding Voltage (DWV)**

There shall be no evidence of arc-over, insulation breakdown, or excessive current leakage (> 5 mA) when mated connectors are tested in accordance with EIA 364-20, method B, condition 1. The following details shall apply:

- Test Voltage: 300 VDC
- Test Duration: 60 seconds
- Points of Measurement: Between signal contact pairs
- Number of readings: 30 minimum

6.4 **Current Rating (Via Current Cycling)**

The temperature rise above ambient shall not exceed 30 degrees C when all contacts are powered at their maximum rating of a 0.5A (per section 4.2). Test shall be performed in still air with an ambient temperature of 25°C. Connector's shall be cycled in one hour durations, 96 times, with the power being on for 45 minutes, followed by the power being turned off for 15 minutes. Temperature shall be measured after the 96th cycle.

6.5 **Differential Impedance**

The impedance of a mated cable to a corresponding board connector shall be 100 ± 10 ohms when tested with a rise time of 70 ps (20% - 80%).

NUMBER GS-12-650	TYPE PRODUCT SPECIFICATION		
TITLE Mini-SAS HD Internal Cable to Board Connector System		PAGE 4 of 4	REVISION A
		AUTHORIZED BY David Lord	DATE 2012-10-11
CLASSIFICATION UNRESTRICTED			

7.0 MECHANICAL REQUIREMENTS

7.1 **Mating / Un-mating Forces (Latch Disengaged)**

The force to mate a cable connector with a corresponding board connector shall not exceed 1.7 N per contact. The un-mating force shall not exceed 0.8 N per contact. Connectors shall be mated at a rate of 25mm per minute with the latch disengaged.

7.2 **Latch Mating Force**

The force to mate a cable connector with the latch engaged to a corresponding board connector shall be 10 N maximum per module in addition to the maximum contact mating force of 1.7 N per contact as specified per section 7.1 (Mating / Un-mating Forces).

7.3 **Cable Plug Pull-out Force (Latch Engaged)**

The mated cable connector, with latch engaged, shall withstand a minimum force of 40 N when an axial load is applied directly to the cable connector. Force shall be applied at a rate of 25mm per minute.

7.4 **Cable Strain Relief (Un-mated)**

The cable shall withstand a minimum force of 100 N when an axial load is applied directly to the cable. Force shall be applied at a rate of 25mm per minute.

7.5 **Wire Flex**

Testing shall be performed in accordance with EIA-364-41 with the exception of section 4.2.5. The cable shall show no physical damage and maintain proper impedance as specified in section 6.4 after being flexed 140°, 20 times, with a 26 N tension force applied.

7.6 **Cable Minimum Bend Radius**

The cable shall show no physical damage and maintain proper impedance as specified in section 6.4 after being bent in one axis using 2 bends 180° apart. It should be bent in perpendicular to the plane of the flat cable. The bend radius at 76mm from the cable exit of the housing should be 10 mm.

7.7 **Press-Fit Insertion Forces**

Perform in accordance with IEC 60352-5 section 5.2.2.2. Press fit of the contact terminals shall be inserted into standard size plated through holes. The maximum insertion force shall be 18 N per press fit pin. Rate = 25mm/min

7.8 **Press-Fit Withdrawal Forces**

Perform in accordance with IEC 60352-5 section 5.2.2.3. Press fit of the contact terminals shall be pulled out of standard size plated through holes. The minimum withdrawal force shall be 3 N per press fit pin. Rate = 10mm/min

7.9 **Connector Longitudinal Loading**

Mated connectors shall withstand a minimum force of 30 N when tested as shown in the Figure 1 shown below, as well as the opposite direction (from bottom). Force shall be applied at a rate of 25mm per minute with a 6mm diameter pin (with a full radius tip) until an open circuit is detected.

7.10 **Connector Latitudinal Loading**

Mated connectors shall withstand a minimum force of 30 N when tested as shown in the figure 2 shown below. Test only needs to be performed from one side for this symmetrical connector interface. Force shall be applied at a rate of 25mm per minute with a 6mm diameter pin (with a full radius tip) until an open circuit is detected.

NUMBER GS-12-650	TYPE PRODUCT SPECIFICATION		
TITLE Mini-SAS HD Internal Cable to Board Connector System		PAGE 5 of 5	REVISION A
		AUTHORIZED BY David Lord	DATE 2012-10-11
		CLASSIFICATION UNRESTRICTED	

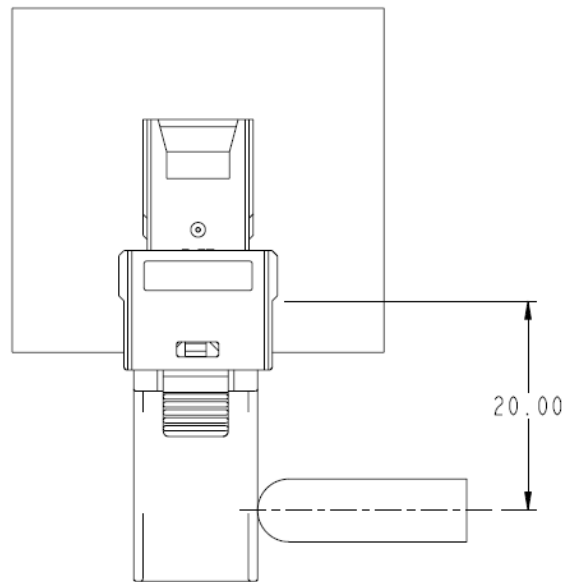
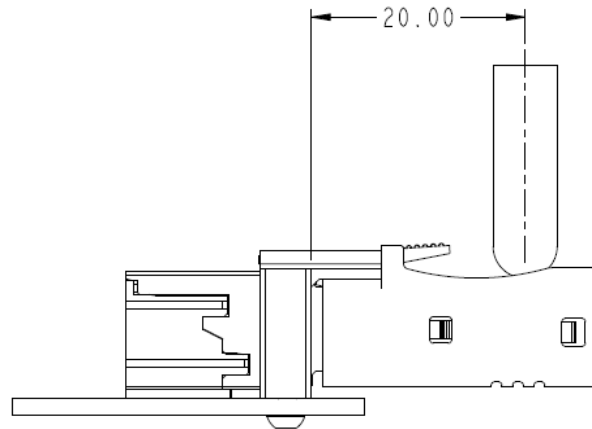



Figure 1: Longitudinal Loading

Figure 2: Latitudinal Loading

7.11 Durability

Perform in accordance with EIA 364-09C. Use standard laboratory procedure as applicable to the product. The following details shall apply:

- Number of cycles: 250 total mating cycles
- Cycling rate: 125 mm per minute
- No physical damage
- Maximum change in contact resistance of 10 mΩ

NUMBER GS-12-650	TYPE PRODUCT SPECIFICATION		
TITLE Mini-SAS HD Internal Cable to Board Connector System		PAGE 6 of 6	REVISION A
		AUTHORIZED BY David Lord	DATE 2012-10-11
		CLASSIFICATION UNRESTRICTED	

7.12 Pre-conditioning

Perform in accordance with EIA 364-09C. Use standard laboratory procedure as applicable to the product. The following details shall apply:

- Number of cycles: 50 total mating cycles
- Cycling rate: 125 mm per minute
- No evidence of physical damage

7.13 Screw Torque

The mounting screw on the receptacle connector shall withstand a torque of 200 N-mm minimum without stripping of the screw threads.

8.0 ENVIRONMENTAL REQUIREMENTS

8.1 Temperature Life

Perform in accordance with EIA 364-17, Method A, test condition 4. Cable and board connector shall remain mated without any electrical load. The following details shall apply:

- Temperature: 105°C ± 2°C
- Duration: 840 hours
- Maximum change in contact resistance of 10 mΩ

8.2 Temperature Life Preconditioning

Perform in accordance with EIA 364-17, Method A, test condition 4. Cable and board connector shall remain mated without any electrical load. The following details shall apply:

- Temperature: 105°C ± 2°C
- Duration: 336 hours

8.3 Thermal Shock

Perform in accordance with EIA 364-32, Method A, test condition I. The following details shall apply:

- Number of cycles: 10
- Temperature range: -55 to + 85°C
- Time at each temperature: 30 minutes minimum
- Transfer time: 30 seconds maximum

8.4 Cyclical Humidity and Temperature

Samples are to be exposed to cyclical humidity and temperature in accordance with EIA 364-31, Method III. Samples are to be subjected to 25 cycles of 3 hour duration for a total of 75 hours.

A cycle consists of the following steps:

- 0.5 hour ramp from 25°C at 80% RH to 65°C at 50% RH
- 1 hour dwell at 65°C at 50% RH
- 0.5 hour ramp down from 65°C at 50% RH to 25°C at 80% RH
- 1 hour dwell at 25°C at 80% RH

NUMBER GS-12-650	TYPE PRODUCT SPECIFICATION		
TITLE Mini-SAS HD Internal Cable to Board Connector System		PAGE 7 of 7	REVISION A
		AUTHORIZED BY David Lord	DATE 2012-10-11
		CLASSIFICATION UNRESTRICTED	

8.5 Mechanical Vibration

Perform in accordance with EIA 364-28, Test Condition VII, Test condition letter D. Mated samples are subjected to 3.10G rms between 20 and 500 Hz for 15 minutes in each of 3 mutually perpendicular planes. The following details shall apply:

- Samples are to be rigidly mounted.
- No discontinuities greater than 1 micro-second are to occur during testing.
- Maximum change in contact resistance of 10 mΩ

8.6 Mechanical Shock

Perform in accordance with EIA 364-27, Test Condition H. Mated samples subject to 30G, half-sine shock pulses of 11 milliseconds duration. Samples are to be rigidly mounted. 3 shocks in each direction applied in 3 mutually perpendicular planes (18 total).

8.7 Mixed Flowing Gas (MFG)

Perform in accordance with EIA 364-65. Unmated board connectors shall be subjected to environmental class IIA gas exposure for 224 hours with half of the samples mated and half un-mated followed by 112 hours with all samples mated.

8.8 Thermal Disturbance

Samples are to be cycled 10 times between 15±3°C and 85±3°C. Temperatures are as measured on the part. Ramp rate to be a minimum of 2°C per minute and dwell time should ensure that the connectors reach the temperature extremes for a minimum of 5 minutes.

8.9 Reseat

Manually un-mate and mate the connector pair for 3 cycles.

9.0 QUALITY ASSURANCE PROVISIONS

9.1 Equipment Calibration

All test equipment and inspection facilities used in the performance of any test shall be maintained in a calibration system in accordance with ANSI Z-540 and ISO 9000.

9.2 Inspection Conditions

Unless otherwise specified herein, all inspections shall be performed under the following ambient conditions:

- Temperature: 25 ± 5° C.
- Relative Humidity: 30% to 60%
- Barometric pressure: Local ambient

9.3 Sample Quantity and Description

Samples used for qualification testing shall be samples that were manufactured using standard production equipment and procedures. The quantity of samples needed for each test sequence is shown in Table 2.

NUMBER GS-12-650	TYPE PRODUCT SPECIFICATION		
TITLE Mini-SAS HD Internal Cable to Board Connector System		PAGE 8 of 8	REVISION A
		AUTHORIZED BY David Lord	DATE 2012-10-11
		CLASSIFICATION UNRESTRICTED	

9.4 Acceptance

Electrical and mechanical requirements placed on test samples as indicated in the sections of this specification shall be established from test data using appropriate statistical techniques or shall otherwise be customer specified, and all samples tested in accordance with this product specification shall meet the stated requirements.

Failures attributed to equipment, test set-up or operator error shall not disqualify the product. If product failure occurs, corrective action shall be taken and samples resubmitted for qualification.

9.5 Qualification Testing

Qualification testing shall be performed on samples that were produced with equipment and procedures used in normal production. Testing shall be performed per the test sequences shown in Table 1.

9.6 Re-qualification testing

If any of the following conditions occur, the responsible Product Engineer shall initiate re-qualification testing consisting of all applicable test sequences shown in Table 1.

- A significant design change is made to existing product, which impacts product form, fit or function. Examples of significant change include, but shall not be limited to, changes made to the contact plating, base material or base material composition of any component, contact interface geometry, etc.
- A significant change is made to the manufacturing process, which impacts the product form, fit or function.
- A significant event occurs during production or end use requiring corrective action to be taken relative to the product design or manufacturing process.

NUMBER GS-12-650	TYPE PRODUCT SPECIFICATION		
TITLE Mini-SAS HD Internal Cable to Board Connector System		PAGE 9 of 9	REVISION A
		AUTHORIZED BY David Lord	DATE 2012-10-11
		CLASSIFICATION UNRESTRICTED	

			Cable Testing	Electrical Testing	Mechanical Tests	Current Rating	Latch Forces	EON Forces	Connector Forces	Environmental Tests	Temperature Life
TEST DESCRIPTION	SECTION	TEST GROUP									
		1	2	3	4	5	6	7	8	9	
Electrical Tests	Visual Examination	5.2	1,9	1,15	1,13	1,3	1,4	1,4,6	1,3,5	1,12	1,11
	Low Level Contact Resistance (LLCR)	6.1		2,4,8,12,14	2,5,7,9,11					2,4,7,9,11	2,6,8,10
	Insulation Resistance (IR)	6.2		5,10							
	Dielectric Withstanding Voltage (DWV)	6.3		6,11							
	Current Rating (Via Current Cycling)	6.4				2					
	Differential Impedance	6.5	2,4,6,8								
Mechanical Tests	Mating / Un-mating forces	7.1			3,12						3,5
	Latch Mating Force	7.2					2				
	Cable Plug Pull-out Force (Latch Engaged)	7.3					3				
	Cable Strain Relief (un-mated)	7.4	7								
	Wire Flex	7.5	5								
	Cable Minimum Bend Radius	7.6	3								
	Press-Fit Insertion Forces	7.7						2			
	Press-Fit Withdrawal Forces	7.8						3			
	Connector Longitudinal Loading	7.9							2		
	Connector Latitudinal Loading	7.10							4		
	Durability	7.11			4						
	Pre-conditioning	7.12		3						3	4
	Screw Torque	7.13							5		
Environmental Tests	Temperature Life	8.1									7
	Temperature Life Pre-Conditioning	8.2			6					5	
	Thermal Shock	8.3		7							
	Cyclical Humidity and Temperature	8.4		9							
	Mechanical Vibration	8.5			8						
	Mechanical Shock	8.6			10						
	Mixed Flowing Gas (MFG)	8.7								6	
	Thermal Disturbance	8.8								8	
	Reseat	8.9		13						10	9

Table 1 – Product Test Sequences

NUMBER GS-12-650	TYPE PRODUCT SPECIFICATION		
TITLE Mini-SAS HD Internal Cable to Board Connector System		PAGE 10 of 10	REVISION A
		AUTHORIZED BY David Lord	DATE 2012-10-11
CLASSIFICATION UNRESTRICTED			

	Test Group	Number of Cables	Cable Description	Number of LLCR Boards	Number of Continuity Boards	Number and Type of Receptacle
Cable Testing	1	6	30 AWG 0.5 m Single Ended	0	1	1 (1x1)
Electrical Testing	2	12	30 AWG 0.5 m Single Ended	3	0	12 (1x1) 6 unmounted
Mechanical	3	12	30 AWG 0.5 m Single Ended	2	1	3 (1x4)
Current Rating	4	4	30 AWG 0.5 m Single Ended	0	1	1 (1x4)
Latch Forces	5	6	30 AWG 0.5 m Single Ended	0	3	6 (1x1)
EON Forces	6	0	30 AWG 0.5 m Single Ended	0	2	3 (1x1)
Connector Forces	7	6	30 AWG 0.5 m Single Ended	0	3	6 (1x1)
Environmental Tests	8	12	30 AWG 0.5 m Single Ended	6	0	12 (1x1)
Temperature Life	9	6	30 AWG 0.5 m Single Ended	6	0	6 (1x1)
Total	--	64	30 AWG 0.5 m Single Ended	17	11	46 (1x1) 4 (1x4) 6 unmounted

Table 2 – Product Test Sample Quantities

NUMBER GS-12-650	TYPE PRODUCT SPECIFICATION		
TITLE Mini-SAS HD Internal Cable to Board Connector System		PAGE 11 of 11	REVISION A
		AUTHORIZED BY David Lord	DATE 2012-10-11
CLASSIFICATION UNRESTRICTED			

10.0 REVISION RECORD

REV	PAGE	DESCRIPTION	EC #	DATE
A	All	Release		2012-10-11