

Hydraulic Crimping Head 1490747-1

Figure 1

1. INTRODUCTION

This instruction sheet provides operation and maintenance instructions for the 12 Ton Titanium Crimping Head 1490747-1. See Figure 1.

The crimping head is designed to use dies that crimp the terminals in Figure 2. Figure 2 also lists the wire sizes onto which the terminals and splices are crimped, as well as the instruction sheet for the crimping dies.

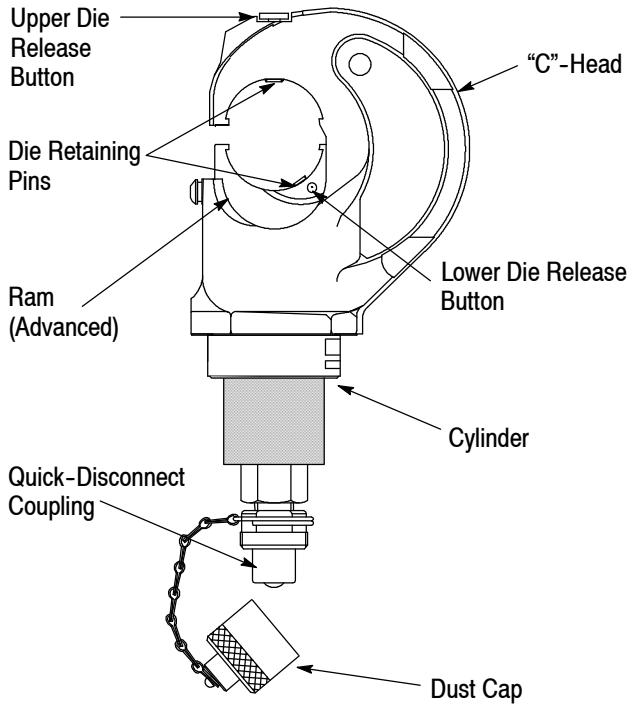
| Terminals | Wire Size (AWG) | Instruction Sheet |
|--------------------------------------|-----------------|-------------------|
| AMPOWER* Terminals and Splices | 6 Through 3/0 | 408-8703 |
| SOLISTRAND* Terminals and Splices | 8 Through 4/0 | 408-8691 |
| TERMINYL* Terminals and Splices | 8 Through 4 | 408-8704 |

Figure 2

NOTE

Dimensions on this document are in metric units [with U. S. customary units in brackets], unless otherwise specified.

2. DESCRIPTION (Figure 1)

Main components of 12 Ton Titanium Crimping Head 1490747-1 include a "C"-head, which houses the stationary die, the upper and lower die release buttons, a cylinder which contains the head's hydraulic chamber, a piston (ram) which holds and controls the moving die, and a quick-disconnect coupling (cylinder half) which mates with the coupling on the hose to release or supply pressure. A dust cap covers the quick-disconnect coupling.

3. INSTALLATION
3.1. Head Installation

Prior to installing the head, ensure that the pump and hose being used are working properly, and are adjusted to and rated at 10,000 psi. An incorrectly adjusted or rated pump/hose could result in severe tooling damage, as well as personal injury.

1. Release the hydraulic pressure to the hose. Disconnect electric power unit from power supply.
2. Remove protective dust caps.
3. Thoroughly clean the coupling on the pump/hose and the coupling on the crimping head.
4. Mate both quick-disconnect couplings and tighten the collar of the coupler assembly on the hose.



Oil flow must be unobstructed between the power unit and the crimping head. Ensure that all couplings are fully mated and tightened.

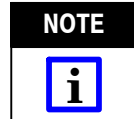

If a crimping head must be removed after the power unit was in operation, be sure to release the pressure in the hydraulic system. When using Hydraulic Power Unit 1583660-[], DISCONNECT THE POWER UNIT FROM THE POWER SUPPLY. When using Hydraulic Foot Pump 1583659-1 or Hydraulic Hand Tool 1583661-1, depress the pressure release pedal to release pressure.

3.2. Die Installation

To avoid personal injury, do NOT accidentally depress the footswitch or handle control when installing or removing dies.



Operating the head WITHOUT the crimping dies installed will damage the "C"-Head or ram.

Install the dies as described in the appropriate die instruction sheet. Refer to Figure 2.

4. CRIMPING PROCEDURE

The following procedure provides only general information concerning crimping. Refer to the instructions packaged with the dies (see Figure 2) and power unit for detailed information, including wire stripping dimensions and instructions for positioning terminals and splices in the dies.

1. Insert terminal or splice in the stationary die according to the instructions packaged with the dies.
2. Activate the power unit to advance the dies and hold the terminal or splice in place.
3. Insert stripped wire into the terminal or splice.
4. Activate the power unit to complete the crimp.

5. INSPECTION/MAINTENANCE



Make sure hydraulic pressure is released and power supply is disconnected before following inspection and maintenance procedures, unless otherwise specified in the procedure.

Each crimping head is assembled and inspected before shipment. It is recommended that the crimping head be inspected immediately upon its arrival at your facility, and at regularly scheduled intervals, to ensure that the crimping head has not been damaged during handling. Frequency of inspection depends upon the following:

- Care, amount of use, and handling of the head;
- Type and size of products crimped;
- Degree of operator skill; and
- Environmental conditions.

Once a year, or every 7,500 cycles (whichever comes first), the hydraulic head should be returned to Tyco Electronics for magnetic particle inspection. Additionally, inspect and service the head (as

described in Figure 3) every month or 1,000 cycles, whichever comes first. Refer to Figure 1.

5.1. Cleaning

Remove accumulations of dirt and grease on the crimping head, especially in areas where dies are installed and terminals are crimped. Clean the entire head frequently with a clean, lint-free cloth.

5.2. Visual Inspection

In addition to the inspections listed in Figure 3, inspect the head for nicks, scratches, and cracks. Inspect for cracks especially at the corners of the "C"-head and around the top of the cylinder. Refer to Figure 4.

Inspect the metal surfaces for nicks, cracks, scratches, and excessive wear, especially where sliding contact occurs.

5.3. Crimping Head Check-Out Procedure

If the ram fails to retract after completion of a crimping cycle, the cause may be in the crimping head. To determine whether or not the trouble is in the crimping head, release pressure in the power unit. If the ram retracts, the trouble is not in the crimping head. If ram does NOT retract, refer to Section 6, RETURN/REPAIR.

6. RETURN/REPAIR

Order replacement parts through your Tyco Electronics representative, or call 1-800-526-5142, or send a facsimile of your purchase order to 1-717-986-7605, or write to:

CUSTOMER SERVICE (38-35)
 TYCO ELECTRONICS CORPORATION
 PO BOX 3608
 HARRISBURG PA 17105-3608

Crimping heads may also be returned for evaluation and repair. For tool repair service, contact a Tyco Electronics representative at 1-800-526-5136.

7. REVISION SUMMARY

Revisions to this instruction sheet include:

- Added "Original Instructions" to the instruction sheet

| ITEM TO BE INSPECTED | INSPECTION/PROBLEM | POSSIBLE SOLUTION |
|---------------------------|---|--|
| "C"-Head | Inspect for cracks, gouges, nicks, or galling on the "C"-Head or where the "C"-Head contacts dies. | Return tool for repair (see Section 6, RETURN/REPAIR). |
| | Check to see if the upper die retaining pin does not hold the stationary die in place. | Return tool for repair (see Section 6, RETURN/REPAIR). |
| | Check to see if the upper die release button sticks (it should normally move in and out easily when moderate pressure is applied). | Return tool for repair (see Section 6, RETURN/REPAIR). |
| Cylinder | Inspect for evidence of cracks, gouges, nicks, or galling. | If there are cracks, return the tool for repair (see Section 6, RETURN/REPAIR). For traces of gouges, nicks, or galling: Remove any sharp edges using a fine emery cloth. |
| | Inspect for oil leaks between the cylinder and coupling. | For oil leaks and a sticky coupling, tighten or replace the coupling |
| | Check to see if the coupling sticks to the cylinder (it should normally turn on and off freely when moderate pressure is applied with applied with a wrench). | |
| Quick-Disconnect Coupling | The coupling mates hard or won't mate or release, or it leaks oil, or it sticks at the hose connection. | Replace coupling. |
| Ram | Inspect the ram in the Power "ON" (ram advanced) position for evidence of galling, cracks, or oil leaks between the ram and the cylinder. | If there are cracks or leaks, return the tool for repair (see Section 6, RETURN/REPAIR). If there is galling, remove any sharp edges using a fine emery cloth. |
| | Check to see if the lower die retaining pin does not hold the moving die in place. | Return tool for repair (see Section 6, RETURN/REPAIR). |
| | Check to see if the lower die release button sticks (it should normally move in and out easily when moderate pressure is applied). | Return tool for repair (see Section 6, RETURN/REPAIRS). |
| | Inspect the ram in the Power "OFF" (ram retracted) position to ensure that the ram returns freely to its original position. | Return tool for repair (see Section 6, RETURN/REPAIRS). |

Figure 3

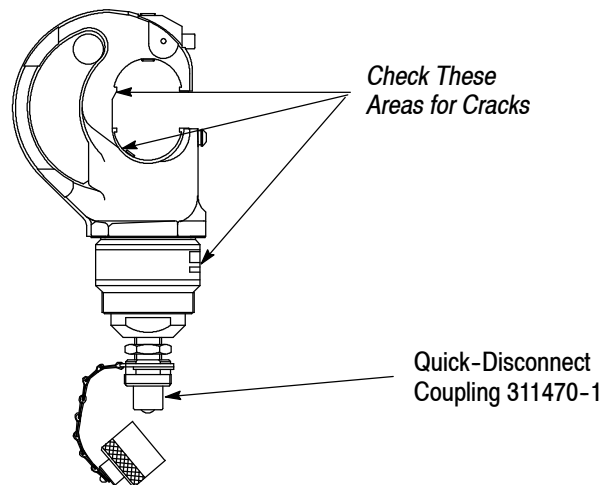

Figure 4