

USB-to-Data Highway Plus Cable

Catalog Number 1784-U2DHP

Topic	Page
Important User Information	2
Environment and Enclosure	3
Install the Cable	5
Configure the DH+ Node Address	11
Consider the Traffic Analyzer Software	11
About Using Multiple Cables	12
Status Indicators	13
Specifications	15
Additional Resources	18

About the Cable

The 1784-U2DHP USB-to-Data Highway Plus Cable lets you connect a computer to a Data Highway Plus (DH+) network via an unused USB port on the computer. You can also use the cable to connect the computer to PLC-5 processors (except for Classic PLC-5 processors, such as PLC-5/10, PLC-5/12, PLC-5/15, and PLC-5/25) or SLC 5/04 processors. Communication on the DH+ link requires the RSLinx Classic software DF1 serial 1770-KF2/1785-KE drive.

Important User Information

Solid-state equipment has operational characteristics differing from those of electromechanical equipment. Safety Guidelines for the Application, Installation and Maintenance of Solid State Controls (Publication [SGI-1.1](#) available from your local Rockwell Automation sales office or online at <http://www.rockwellautomation.com/literature/>) describes some important differences between solid-state equipment and hard-wired electromechanical devices. Because of this difference, and also because of the wide variety of uses for solid-state equipment, all persons responsible for applying this equipment must satisfy themselves that each intended application of this equipment is acceptable.





In no event will Rockwell Automation, Inc. be responsible or liable for indirect or consequential damages resulting from the use or application of this equipment.

The examples and diagrams in this manual are included solely for illustrative purposes. Because of the many variables and requirements associated with any particular installation, Rockwell Automation, Inc. cannot assume responsibility or liability for actual use based on the examples and diagrams.

No patent liability is assumed by Rockwell Automation, Inc. with respect to use of information, circuits, equipment, or software described in this manual.

Reproduction of the contents of this manual, in whole or in part, without written permission of Rockwell Automation, Inc., is prohibited.

Throughout this manual, when necessary, we use notes to make you aware of safety considerations.

	WARNING: Identifies information about practices or circumstances that can cause an explosion in a hazardous environment, which may lead to personal injury or death, property damage, or economic loss.
	ATTENTION: Identifies information about practices or circumstances that can lead to personal injury or death, property damage, or economic loss. Attentions help you identify a hazard, avoid a hazard and recognize the consequences.
	SHOCK HAZARD: Labels may be on or inside the equipment, for example, drive or motor, to alert people that dangerous voltage may be present.
	BURN HAZARD: Labels may be on or inside the equipment, for example, drive or motor, to alert people that surfaces may reach dangerous temperatures.
IMPORTANT	Identifies information that is critical for successful application and understanding of the product.

Environment and Enclosure



ATTENTION: This equipment is intended for use in overvoltage Category II applications (as defined in IEC 60664-1), at altitudes up to 2000 m (6562 ft) without derating.

This equipment is considered Group 1, Class A industrial equipment according to IEC/CISPR 11. Without appropriate precautions, there may be difficulties with electromagnetic compatibility in residential and other environments due to conducted and radiated disturbances.

This equipment is supplied as enclosed equipment. It should not require additional system enclosure when used in locations consistent with the enclosure type ratings stated in the Specifications section of this publication. Subsequent sections of this publication may contain additional information regarding specific enclosure type ratings, beyond what this product provides, that are required to comply with certain product safety certifications.

In addition to this publication, see:

- Industrial Automation Wiring and Grounding Guidelines, Rockwell Automation publication [1770-4.1](#), for additional installation requirements.
- NEMA Standard 250 and IEC 60529, as applicable, for explanations of the degrees of protection provided by different types of enclosure.

Preventing Electrostatic Discharge



ATTENTION: This equipment is sensitive to electrostatic discharge, which can cause internal damage and affect normal operation. Follow these guidelines when you handle this equipment:

- Touch a grounded object to discharge potential static.
 - Do not touch connectors or pins on component boards.
 - Store the equipment in appropriate static-safe packaging when not in use.
-

4 USB-to-Data Highway Plus Cable



At the end of its life, this equipment should be collected separately from any unsorted municipal waste.

IMPORTANT

The cable will not connect to Classic PLC-5 processors, such as PLC-5/10, PLC-5/12, PLC-5/15, and PLC-5/25, without an adapter. An adapter can be purchased separately from third-party companies.

To comply with the CE Low Voltage Directive (LVD), this equipment must be powered from a source compliant with safety extra low voltage (SELV) or protected extra low voltage (PELV).

The 1784-U2DHP cable replaces both the 1784-PCMK communication card and 1784-PCM6 cable (for computers without PCMCIA slots).

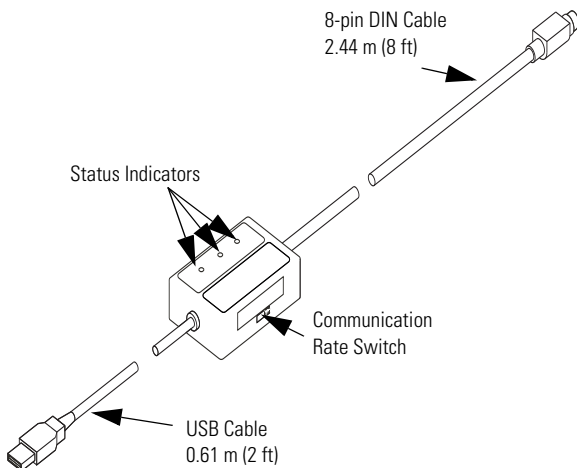

The cable operates at DH+ communication rates of 57.6 Kbps, 115.2 Kbps, and 230.4 Kbps.

IMPORTANT The DH+ communication rate is read only when power is applied. To change the communication rate, you must disconnect the cable from the USB port, use the Communication Rate switch to change the communication rate setting, then reconnect the cable to the USB port.

The 1784-U2DHP cable supports these DH+ network cable lengths.

DH+ Communication Rate	Max. DH+ Network Cable Length
57.6 Kbps	3048 m (10,000 ft)
115.2 Kbps	1524 m (5000 ft)
230.4 Kbps	762 m (2500 ft)

Install the Cable

Follow the procedures on the following pages to install the cable.

Obtain the Device Driver for the Cable

Follow these steps to download the device driver for the cable.

IMPORTANT If RSLinx Classic software, version 2.53 or later, is installed on the computer, the device driver is already installed on the computer. Skip this section.

1. Visit <http://www.rockwellautomation.com/support/pccards>.
2. Click the 1784_u2dhp.inf file.
3. Save the file to a directory on the computer on which you want to install the cable.

Connect and Configure the Cable

1. Insert the end of the cable having the USB connector into an unused USB port on a computer.

The Found New Hardware wizard appears.

TIP If you do not see the Found New Hardware wizard, the drivers have already been installed. If RSLinx Classic software, version 2.53 or later, is installed on the computer, the device driver was installed at C:\Program Files\Rockwell Software\RSLINX\PnP_Drivers\1784-U2DHP.

If you do not see the Found New Hardware wizard, proceed to [step 9](#). Otherwise, continue with the next step.

2. Select No, not this time and click Next.
3. Select Install from a list or specific location and click Next.
4. Select Search for the best driver.
5. Check only the Include this location checkbox.
6. Browse to the location where you saved the 1784_u2dhp.inf file and click OK.
7. Click Next.
8. Click Finish.

TIP If you see a Microsoft Windows error message that displays code 10, disconnect the cable from the USB port, then reconnect the cable to the USB port, so that the Windows operating system recognizes the device.

9. Insert the other end of the cable having the 8-pin mini DIN connector to a device on your Data Highway Plus network.

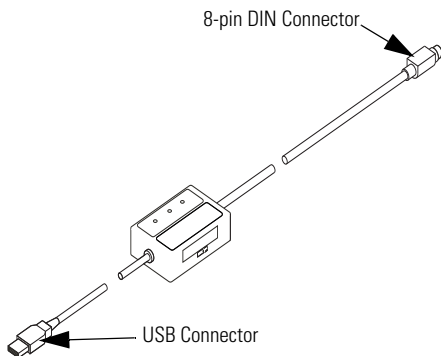

ATTENTION: The USB cable is not to exceed 3.0 m (9.84 ft).

10. Verify which computer COM port the cable is using.

- TIP** The operating system of the computer you are using assigns a COM port to the cable.
- a. Right-click My Computer and choose Manage.
 - b. Select Device Manager.
 - c. Click the + to the left of Ports.
 - d. Make note of the port (for example, COM3) for the 1784-U2DHP cable.

Configure the RSLinx Classic Software Driver for the Cable

Configure the cable driver for use with your DH+ networked device.

RSLinx Classic Software, Version 2.52 and Earlier

Do these steps to configure the cable device driver by using RSLinx Classic software, version 2.52 and earlier.

1. Open RSLinx Classic software and then, from the Communication menu, choose Configure Drivers.
2. From the Available Driver Types pull-down menu, choose RS-232 DF1 Devices.
3. Click Add New.
4. Enter a name for the driver you just added and click OK.

The Configure RS-232 DF1 Devices dialog box appears.

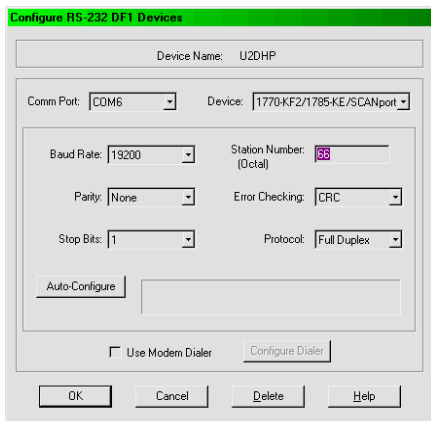

5. Enter configuration information in each field.

In this field	Do this
Comm Port	Select the COM port you verified in step 10 on page 7 .
Device	Select 1770-KF2/1785-KE/SCANport.
Station Number (node address)	Enter the DH+ Station Number for this cable. The default is 0. The 1784-U2DHP cable can use any DH+ network address from 0...77 octal. The first packet sent from RSLinx Classic software to the 1784-U2DHP cable sets the DH+ network address the first time that RSLinx Classic software communicates through the 1784-U2DHP cable after power is applied. See Configure the DH+ Node Address on page 11 .
Error Checking	Select CRC.
Protocol	Select Full Duplex.
Baud Rate	Not used.
Parity	Not used.
Stop Bits	Not used.

6. Click OK.

RSLinx Classic Software, Version 2.53 and Later

Do these steps to configure the cable device driver by using RSLinx Classic software, version 2.53 and later.

1. Open RSLinx Classic software and then, from the Communication menu, choose Configure Drivers.
2. From the Available Driver Types pull-down menu, choose 1784-U2DHP for DH+ devices.
3. Click Add New.
4. Enter a name for the driver you just added and then click OK.

10 USB-to-Data Highway Plus Cable

The Configure 1784-U2DHP dialog box appears.

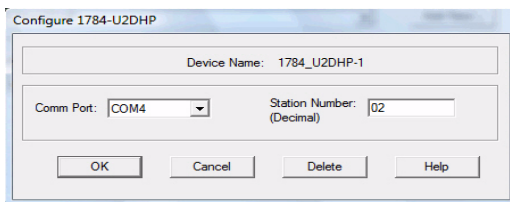

5. Enter configuration information in each field.

In this field	Do this
Comm Port	Select the COM port you verified in step 10 on page 7 .
Station Number (node address)	Enter the DH+ Station Number for this cable. The default is 0. The 1784-U2DHP cable can use any DH+ network address from 0...77 octal. The first packet sent from RSLinx Classic software to the 1784-U2DHP cable sets the DH+ network address the first time that RSLinx Classic software communicates through the 1784-U2DHP cable after power is applied. See Configure the DH+ Node Address on page 11 .

6. Click OK.

IMPORTANT Do not disconnect the cable without first using RSLinx Classic software to stop the driver. Disconnecting the cable without stopping the driver can shut down or cause RSLinx Classic software to become unresponsive.

Configure the DH+ Node Address

The cable DH+ node address (station number) is automatically set the first time the cable sees traffic from RSLinx software to the DH+ network.

To change the node address of the cable, you must do these steps.

1. In RSLinx Classic software, from the Communication menu, choose Configure Drivers.
2. Choose the driver and click Stop.
3. Click Configure.
4. Enter the new node address and click OK.
5. Cycle power to the cable by disconnecting the 1784-U2DHP cable USB connector from the USB port, then reconnecting it.
6. Verify the driver is still selected and click Start.
7. Initiate traffic from RSLinx Classic software to the DH+ network.
 - a. From the Communication menu, choose RSWho.
 - b. Choose the driver from the list.

Consider the Traffic Analyzer Software

The 1784-U2DHP cable is designed to work with Frontline's NetDecoder traffic analyzer software. For more information on Frontline's product, go to <http://www.rockwellautomation.com/encompass> or <http://www.fte.com>.

About Using Multiple Cables

Once you have installed the device driver for a 1784-U2DHP cable, a unique COM port will be created and associated with that module (for example, COM9). If you connect a different 1784-U2DHP cable to the same computer, a new COM port will be created and associated with the new cable (for example, COM10).

Each time you connect a new 1784-U2DHP cable to the computer, refer to [step 10](#) on [page 7](#) to determine the correct COM port for the additional cables.

When you are using multiple 1784-U2DHP cables on the same computer, you must do one of these procedures.

- Change the RSLinx Classic software driver settings to specify the appropriate COM port for the connected cable.
- Configure multiple RSLinx Classic software drivers.

Product Dimensions

The following illustration shows the product dimensions.

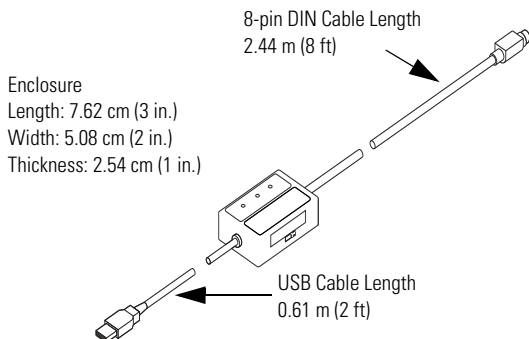

Status Indicators

The following table describes the cable status indicators.

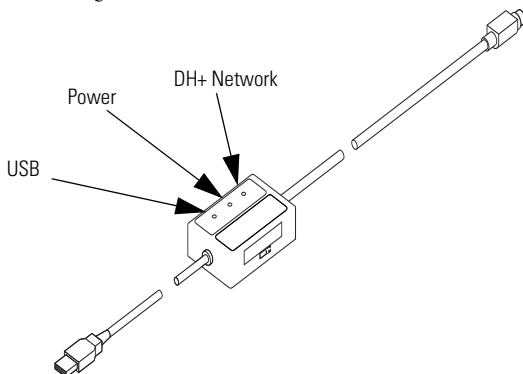

Cable Status Indicators

Indicator	State	Description
USB	Solid green	The cable is configured, but no network traffic is present.
	Blinking green	Network traffic is present.
	Off	Unable to transfer data. <ul style="list-style-type: none"> • Disconnected from host. • In one of the following states: <ul style="list-style-type: none"> – Default – Powered – Address – Suspend
Power	Solid green	The cable is powered.
	Off	No power to the cable.

14 USB-to-Data Highway Plus Cable

Cable Status Indicators

Indicator	State	Description
DH+ Network	Off	Node address not present.
	Blinking green	Not connected to the DH+ network. Incorrect DH+ communication rate selected. Break or short in wiring.
	Solid green	Communicating with the DH+ network.
	Blinking red	Duplicate node detected.
	Solid red	Internal diagnostic test failed.

Specifications

Technical Specifications - 1784-U2DHP

Attribute	Value
Enclosure type rating	Meets IP30
Power dissipation, max	1.575 W max
Supply voltage	5.00V DC 5.25V DC, max
Supply current	125 mA
Power consumption, max	1.575 W
Isolation voltage	30V (continuous), Basic Insulation Type DH+ to USB, Type tested at 500V AC for 60 s
Wiring category	2 - on communication ports ⁽¹⁾

- (1) Use this Conductor Category information for planning conductor routing. Refer to Industrial Automation Wiring and Grounding Guidelines, publication [1770-4.1](#).

Environmental Specifications - 1784-U2DHP

Attribute	Value
Temperature, operating IEC 60068-2-1 (Test Ad, Operating Cold), IEC 60068-2-2 (Test Bd, Operating Dry Heat), IEC 60068-2-14 (Test Nb, Operating Thermal Shock)	0...55 °C (32...131 °F)
Temperature, nonoperating IEC 60068-2-1 (Test Ab, Unpackaged Nonoperating Cold), IEC 60068-2-2 (Test Bb, Unpackaged Nonoperating Dry Heat), IEC 60068-2-14 (Test Na, Unpackaged Nonoperating Thermal Shock)	-10...85 °C (14...185 °F)
Relative humidity IEC 60068-2-30 (Test Db, Unpackaged Damp Heat)	5...95% noncondensing
Shock, nonoperating IEC 60068-2-27 (Test Ed, Unpackaged Shock)	1000 mm (3.28 ft)
Emissions CISPR 11	Group 1, Class A
ESD immunity IEC 61000-4-2	8 kV air discharges
Radiated RF immunity IEC 61000-4-3	10V/m with 1 kHz sine-wave 80% AM from 80...2000 MHz 10V/m with 200 Hz 50% Pulse 100% AM at 900 MHz 10V/m with 200 Hz 50% Pulse 100% AM at 1890 MHz 10V/m with 1 kHz sine-wave 80% AM from 2000... 2700 MHz

Environmental Specifications - 1784-U2DHP

Attribute	Value
EFT/B immunity IEC 61000-4-4	±2 kV at 5 kHz on DH+ port
Surge transient immunity IEC 61000-4-5	±2 kV line-earth (CM) on DH+ port
Conducted RF immunity IEC 61000-4-6	10V rms with 1 kHz sine-wave 80% AM from 150 kHz... 80 MHz on DH+ port

Certifications - 1784-U2DHP

Certification⁽¹⁾	Value
c-UL-us	UL Listed Industrial Control Equipment, certified for US and Canada. See UL File E65584.
CE	European Union 2004/108/EC EMC Directive, compliant with: EN 61326; Meas./Control/Lab., Industrial Requirements EN 61000-6-2; Industrial Immunity EN 61000-6-4; Industrial Emissions EN 61131-2; Programmable Controllers (Clause 8, Zone A & B)
C-Tick	AS/NZS CISPR 11; Industrial Emissions

- (1) When marked. See the Product Certification link at <http://www.ab.com> for Declarations of Conformity, Certificates, and other certification details.

Additional Resources

These documents contain additional information concerning related Rockwell Automation products.

Resource	Description
Industrial Automation Wiring and Grounding Guidelines, publication 1770-4.1	Provides general guidelines for installing a Rockwell Automation industrial system.
Product Certifications website, http://www.ab.com	Provides declarations of conformity, certificates, and other certification details.

Notes:

Rockwell Automation Support

Rockwell Automation provides technical information on the Web to assist you in using its products. At <http://www.rockwellautomation.com/support/>, you can find technical manuals, a knowledge base of FAQs, technical and application notes, sample code and links to software service packs, and a MySupport feature that you can customize to make the best use of these tools.

For an additional level of technical phone support for installation, configuration, and troubleshooting, we offer TechConnect support programs. For more information, contact your local distributor or Rockwell Automation representative, or visit <http://www.rockwellautomation.com/support/>.

Installation Assistance

If you experience a problem within the first 24 hours of installation, please review the information that's contained in this manual. You can also contact a special Customer Support number for initial help in getting your product up and running.

United States or Canada	1.440.646.3434
Outside United States or Canada	Use the Worldwide Locator at http://www.rockwellautomation.com/support/americas/phone_en.html , or contact your local Rockwell Automation representative.

New Product Satisfaction Return

Rockwell Automation tests all of its products to ensure that they are fully operational when shipped from the manufacturing facility. However, if your product is not functioning and needs to be returned, follow these procedures.

United States	Contact your distributor. You must provide a Customer Support case number (call the phone number above to obtain one) to your distributor to complete the return process.
Outside United States	Please contact your local Rockwell Automation representative for the return procedure.

Documentation Feedback

Your comments will help us serve your documentation needs better. If you have any suggestions on how to improve this document, complete this form, publication [RA-DU002](#), available at <http://www.rockwellautomation.com/literature>.

Allen-Bradley, Rockwell Software, Rockwell Automation, Data Highway Plus, RSLinx Classic, PLC-5, SLC, and TechConnect are trademarks of Rockwell Automation, Inc.

Trademarks not belonging to Rockwell Automation are property of their respective companies.

Rockwell Otomasyon Ticaret A.Ş., Kar Plaza İş Merkezi E Blok Kat:6 34752 İçerenköy, İstanbul, Tel: +90 (216) 5698400

www.rockwellautomation.com

Power, Control and Information Solutions Headquarters

Americas: Rockwell Automation, 1201 South Second Street, Milwaukee, WI 53204 USA, Tel: (1) 414.382.2000, Fax: (1) 414.382.4444

Europe/Middle East/Africa: Rockwell Automation, Vorstlaan/Boulevard du Souverain 36, 1170 Brussels, Belgium, Tel: (32) 2 663 0600, Fax: (32) 2 663 0640

Asia Pacific: Rockwell Automation, Level 14, Core F, Cyberport 3, 100 Cyberport Road, Hong Kong, Tel: (852) 2887 4788, Fax: (852) 2508 1846

Publication 1784-IN045C-EN-P - May 2010

PN-76634

Supersedes Publication 1784-IN045B-EN-P - March 2009

Copyright © 2010 Rockwell Automation, Inc. All rights reserved. Printed in the U.S.A.