

EKI-1361 EKI-1362 EKI-1361-MB EKI-1362-MB

1-Port RS-232/422/485 to 802.11a/b/g/n WLAN Serial Device Server
2-Port RS-232/422/485 to 802.11a/b/g/n WLAN Serial Device Server
1-Port RS-232/422/485 to 802.11a/b/g/n WLAN Modbus Gateway
2-Port RS-232/422/485 to 802.11a/b/g/n WLAN Modbus Gateway

NEW

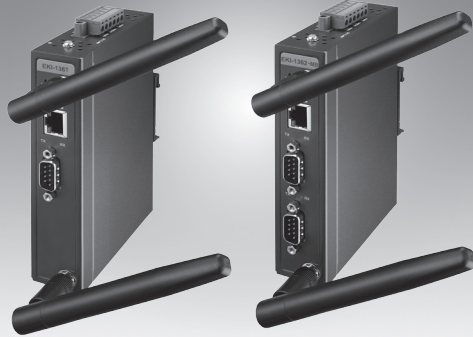

EKI-1361

EKI-1362



Features

- Link any serial device to an IEEE 802.11a/b/g/n network
- Supports 802.11n MIMO 2T2R
- WLAN transmission rates up to 300 Mbps
- Supports secure access with WEP, WPA/WPA2-Personal, WPA/WPA2-Enterprise
- Provides COM port redirection, TCP, UDP, and pair connection modes
- Supports up to 921.6 kbps and any baud rate setting
- Provides web-based configuration and Windows utility
- Allows a maximum of five hosts to access one serial port
- Modbus TCP and Modbus RTU support
- Selective dual band 2.4 or 5 GHz

Introduction

The EKI-1361 and EKI-1362 wireless serial device servers bring RS-232/422/485 to wireless LAN. They allow nearly any device with a serial port to connect and share a wireless LAN. The EKI-1361 and EKI-1362 provide a quick, simple, and cost-effective way to bring remote management and data accessibility to thousands of devices that cannot otherwise connect to a network. With the EKI-1361 and EKI-1362, your existing serial devices can be used with the most common operating systems without the need to write special drivers. Moreover, you can make serial devices communicate directly with other devices peer-to-peer, thus eliminating the need for intermediate host PCs and software programming. This saves a considerable amount of cost and effort. Additionally, you can actively request data or issue commands from the RS-232/422/485 side or wireless LAN side with bilateral data transmission. Thus, the EKI-1361 and EKI-1362 are especially suitable for remote monitoring environments such as security systems, factory automation, SCADA, transportation, and more.

Specifications

Ethernet Communications

- **Port Type** RJ45
- **No. of Ports** 1
- **Speed** 10/100/1000 Mbps

Wireless LAN Communications

- **Compatibility** IEEE 802.11a/b/g/n
- **Speed** Up to 300Mbps
- **Network Mode** Infrastructure
- **Antenna Connector** Reverse SMA
- **No. of Antenna** 2 (supports 2T2R)
- **Free Space Range** Open space 100 m
- **Wireless Security** WEP, WPA/WPA2-Personal, WPA/WPA2-Enterprise

Serial Communications

- **Port Type** RS-232/422/485, software selectable
- **No. of Ports** EKI-1361: 1
EKI-1362: 2
- **Port Connector** DB9 male
- **Data Bits** 5, 6, 7, 8
- **Stop Bits** 1, 1.5, 2
- **Parity** None, Odd, Even, Space, Mark
- **Baud Rate** 50 bps ~ 921.6 kbps, any baud rate setting
- **Serial Signals** RS-232: TxD, RxD, CTS, RTS, DTR, DSR, DCD, RI, GND
RS-422: TxD+, TxD-, RxD+, RxD-, GND
RS-485: Data+, Data-, GND
- **Protection** 15 KV ESD for all signals

Software

- **OS Support** 32-bit/64-bit Windows XP/Vista/7/8/8.1/10, Windows Server 2003/2008/2008 R2/2012/2012 R2 and Linux
- **Utility Software** Advantech EKI Device Configuration Utility
- **Operation Modes** Access Point mode/Station mode
Pair connection without AP (peer to peer) mode
EKI-1361/2
COM port redirection mode (Virtual COM)
TCP/UDP server (polling) mode
TCP/UDP client (event handling) mode

EKI-1361/2-MB

Modbus RTU Master/Slave
Modbus ASCII Master/Slave
Windows utility, Telnet console, Web Browser
ARP, ICMP, IPv4, IPv6, TCP, UDP, BOOTP, DHCP Client, Auto IP, Telnet, DNS, SNMP, HTTP, SMTP, SNTIP

- **Configuration**
- **Protocol**

Mechanics

- **Enclosure** Metal shell with solid mounting kits
- **Mounting** DIN-rail, Wall
- **Dimensions (W x H x D)** 28.5 x 120 x 85.3 mm (1.12" x 4.72" x 3.36")
- **Weight** 0.5 Kg

General

- **LED Indicators** System: Power, System Status
WLAN: Quality, Link/Active
LAN: Link/Active
Serial: Tx, Rx
- **Reboot Trigger** Built-in WDT (watchdog timer)

Power Requirements

- **Power Input** 12 ~ 48 V_{DC}, redundant dual inputs
- **Power Connector** Terminal block
- **Power Consumption** EKI-1361: 8W
EKI-1362: 9W

Environment

- **Operating Temperature** -30 ~ 65 °C (-22 ~ 149 °F)
- **Storage Temperature** -40 ~ 80 °C (-40 ~ 176 °F)
- **Operating Humidity** 10 ~ 95% RH

Regulatory Approvals

- **EMC** CE, FCC Part 15 Subpart B (Class B)

Dimensions

Unit: mm [inch]

EKI-1361

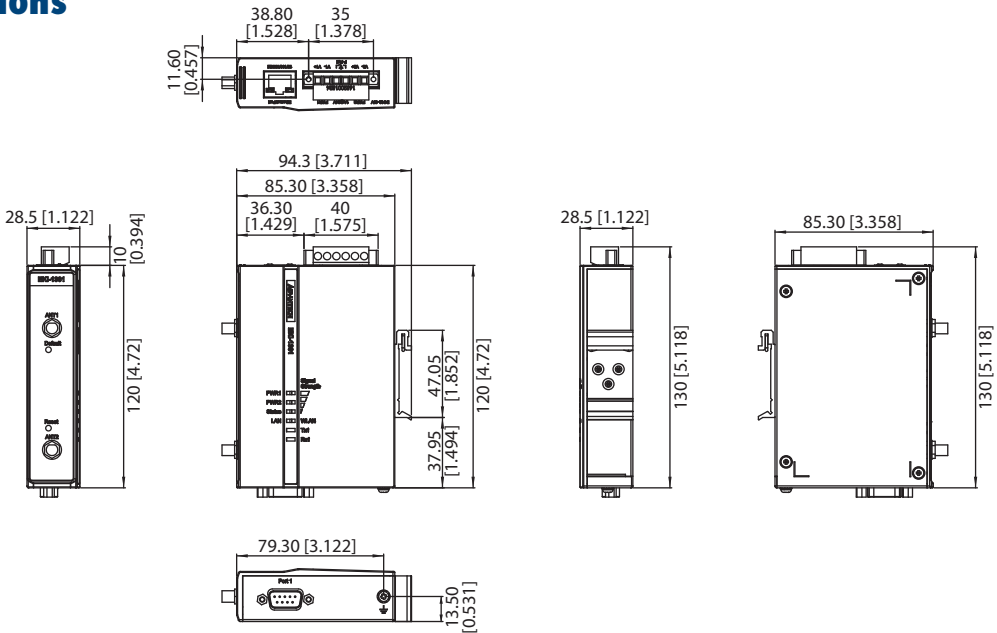

Panel Cut-out Dimensions: 94.3 x 120 x 28.5 mm (3.711" x 4.724" x 1.122")

EKI-1362

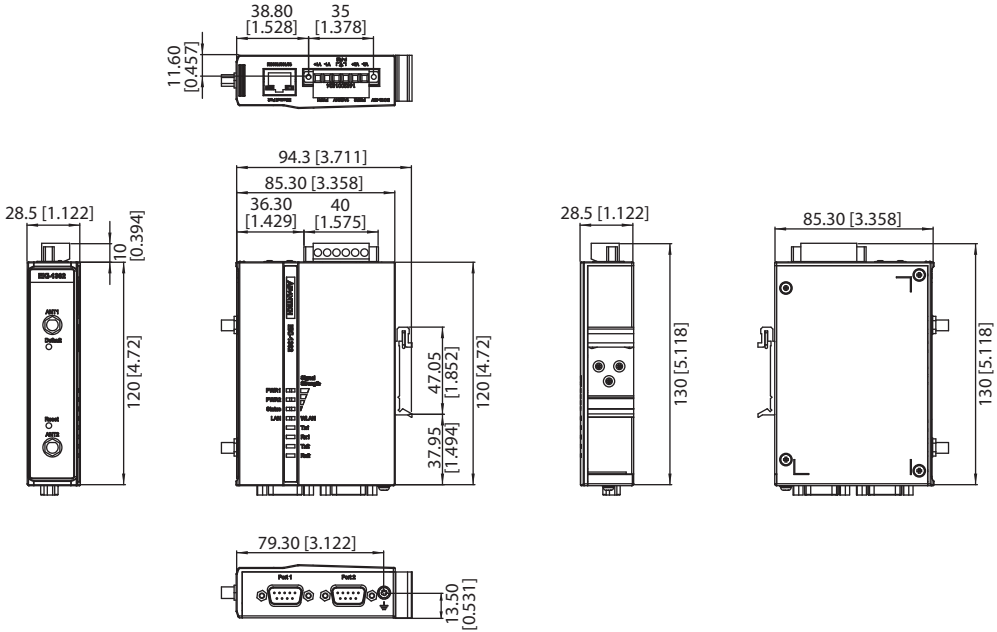

Panel Cut-out Dimensions: 94.3 x 120 x 28.5 mm (3.711" x 4.724" x 1.122")

Ordering Information

- **EKI-1361** 1-port 802.11a/b/g/n WLAN Serial Device Server
- **EKI-1362** 2-port 802.11a/b/g/n WLAN Serial Device Server
- **EKI-1361-MB** 1-port 802.11a/b/g/n WLAN Modbus Gateway
- **EKI-1362-MB** 2-port 802.11a/b/g/n WLAN Modbus Gateway
- **OPT1-DB9** D-Sub9 to Terminal Converter