

PART NAME: KNOB SCALE: 1:1 DATE: 3/16/94 DR. BY HD

THIS DRAWING IS THE PROPERTY OF DAVIES MOLDING COMPANY, IS SUBMITTED SOLELY AS A DESIGN OR ENGINEERING PROJECT. WE ACCEPT NO RESPONSIBILITY WHATSOEVER FOR THE PRACTICAL APPLICATION OF THE PIECES MADE TO THIS DESIGN.

DAVIES MOLDING DESIGNERS & MANUFACTURERS OF KNOBS, HANDLES, CASES & CUSTOM PLASTIC COMPONENTS

P/N	2825-F
M NO.	73
CAVITY	2825
CORE	2825
CAVITY PLUG	2825-F
SLEEVE	2825
PIN	2825
(C) SPRING WASHER	(1) 0.028 (BOTTOM PIN)
INSERT	I1334

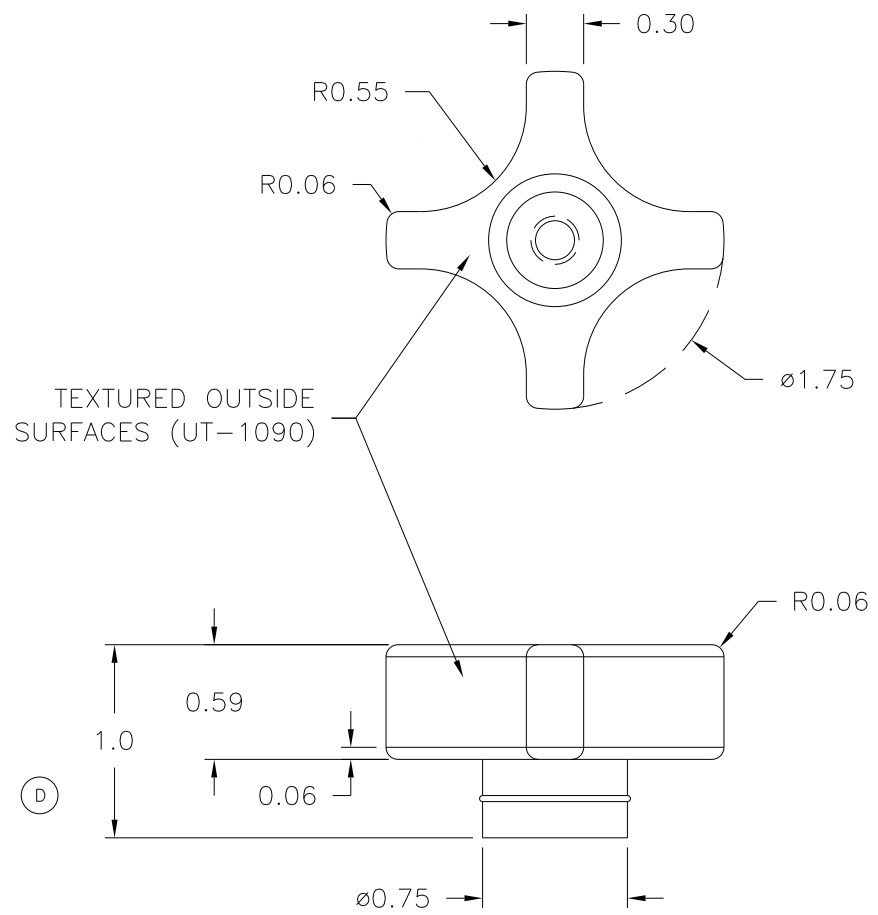

(B) NOTE: (1) 0.028 SPRING WASHER PER BOTTOM PIN IS REQUIRED. NO SPRING WASHER ON THE TOP PIN.

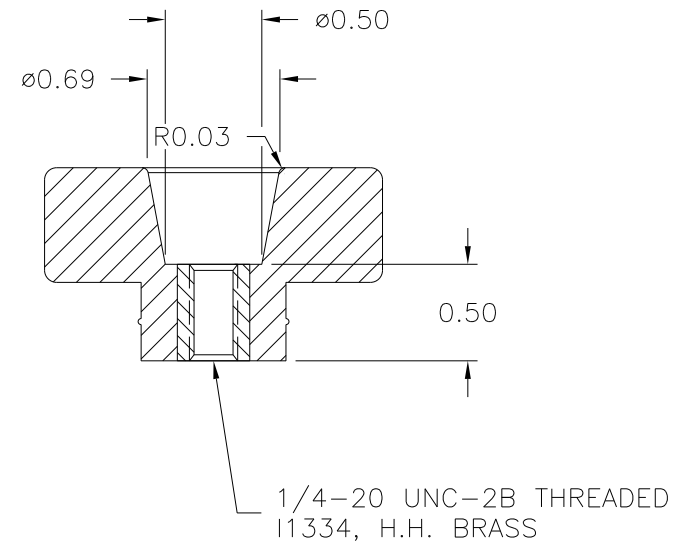

MATERIAL: 20% TALC-FILLED POLYPROPYLENE (BC9)
COLOR: BLACK

(D)	TOLERANCES: UNLESS OTHERWISE SPECIFIED	DO NOT SCALE DRAWING	D	WAS 1.00, ADDED TOLERANCE	EW	7/23/14
	DECIMALS: X.XXX ± .005 X.XX ± .015 X.X ± .03	MM: X.XX ± 0.15MM X.X ± 0.4MM	C	CLARIFIED WASHER INFO.	TS	2/25/02
	FRACTIONS ± 1/64	ANG. ± 1°	B	ADDED PIN WASHER & NOTE	TS	2/5/02
			-	REDRAWN	TL	11/22/99
			A	WAS POLYPROPYLENE	MH	10/21/98
CHANGES						