

# Turbo G5 Module

Low cost module with vector floating point and high-end graphics

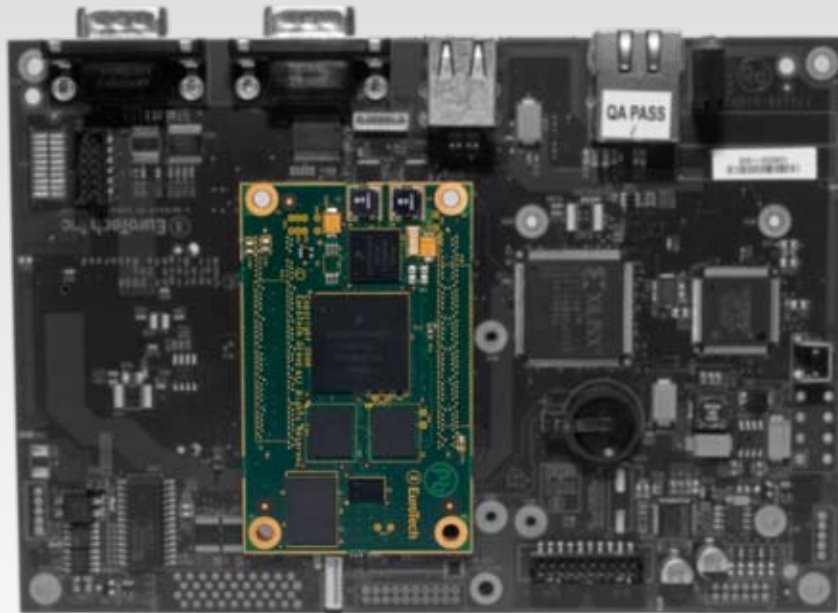

## FEATURES

- Based on Freescale i.MX31 processor with hardware vector floating point
- Modular design for quick customization
- Scalable footprint for optimal efficiency and reduced time-to-market
- 2-D and 3-D graphics including OpenGL-ES and Direct3D-Mobile for high-end multimedia applications
- Windows CE 6.0 and Linux

**The Turbo G5 module, a low power embedded computer-on-module in a small form factor, delivers a powerhouse of features and options.** Based on the Freescale i.MX31 processor, the Turbo G5 module offers hardware vector floating point for applications requiring extensive computations at fast execution times. The 2-D and 3-D graphical capability including support for OpenGL-ES and Direct3D-Mobile allow for comprehensive and quick development for multimedia applications. With this broad list of specifications, the Turbo G5 module is an ideal solution for a range of embedded applications such as hand-held devices, transportation, and infotainment.

The Turbo G5 is mounted onto a carrier board to bring out a comprehensive range of I/O and communications ports. The carrier board can be easily customized (by Eurotech or a third party) to meet unique application requirements while reducing product time-to-market and optimizing costs. Furthermore, the Turbo G5 module can be easily scaled across several carrier board footprints so that OEMs can get the most out of product designs.

# Turbo G5 Module

## Specifications\*

PROCESSOR	32-bit Freescale i.MX31 processor at 532 MHz Vector floating point co-processor
GRAPHICS/VIDEO	Hardware video acceleration encoder 2-D and 3-D graphics with OpenGL-ES and Direct3D-Mobile
MEMORY	128 MB of Mobile DDR (expandable to 256 MB) 32 MB of Flash (expandable to 64 MB)
OPERATING ENVIRONMENTS	Windows CE 5.0 and 6.0 Linux
PHYSICAL/OTHER	Module dimensions 2.9 x 1.8 inches (74 x 46 mm) RoHS compliant Commercial temperature 0° to 70 C° (contact factory for extended temperature options) Real Time Clock Watchdog timer Supply voltage: +3V ÷ +3.6V

## TURBO G5 STANDARD CARRIER BOARD EXPANDABILITY

The Turbo G5 module requires a carrier board. The standard carrier board from Eurotech supports the following features:

- One 10/100BASE-T Ethernet port
- One CAN 2.0 interface
- Two PWM interfaces
- One I2C interface
- One SPI interface
- One LCD interface
- One Camera Sensor Interface
- One USB 2.0 host port (H/F/L speeds)
- One USB 2.0 On-The-Go (OTG) port (H/F/L speed)
- Stereo audio interface
- 128 MB NAND FLASH (expandable)
- Seven GPIO
- Five digital inputs and one digital output
- One 8x8 keypad interface
- Four UART interfaces
- One CompactFlash® slot
- One SD/MMC card slot
- Support for Zigbee and GPS modules from Eurotech
- Support for 802.11b/g embedded wireless module
- Standard carrier board dimensions 4.5 x 6.5 inches (115 x 165 mm)

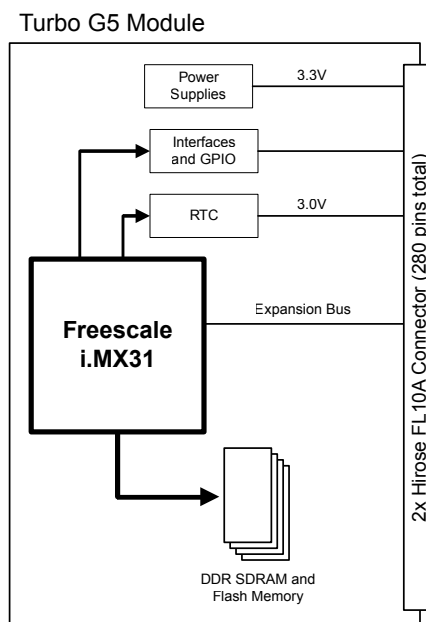

## About Us

Eurotech delivers embedded computer systems for high capability and low power applications, networking and wearable computing solutions, and application framework middleware for multimedia, industrial, transportation, medical, and wireless applications. Eurotech platforms allow OEM and enterprise customers to focus on their core revenue-generating products and services and get to market quickly.

Turbo G5 is a trademark of Eurotech Inc.  
Other trademarks are property of their respective holders.

\*Specifications and features subject to change without notice  
See our website for latest updates and more information  
[www.eurotech-inc.com](http://www.eurotech-inc.com)

CMM4500A Mar2009