

THIS DRAWING IS UNPUBLISHED. RELEASED FOR PUBLICATION
 © COPYRIGHT - By - ALL RIGHTS RESERVED.

LOC	DIST	REVISIONS					
AJ	16	P	LTR	DESCRIPTION	DATE	DWN	APVD
				K1 REV PER ECR-15-005272	03APR2015	RZ	MC

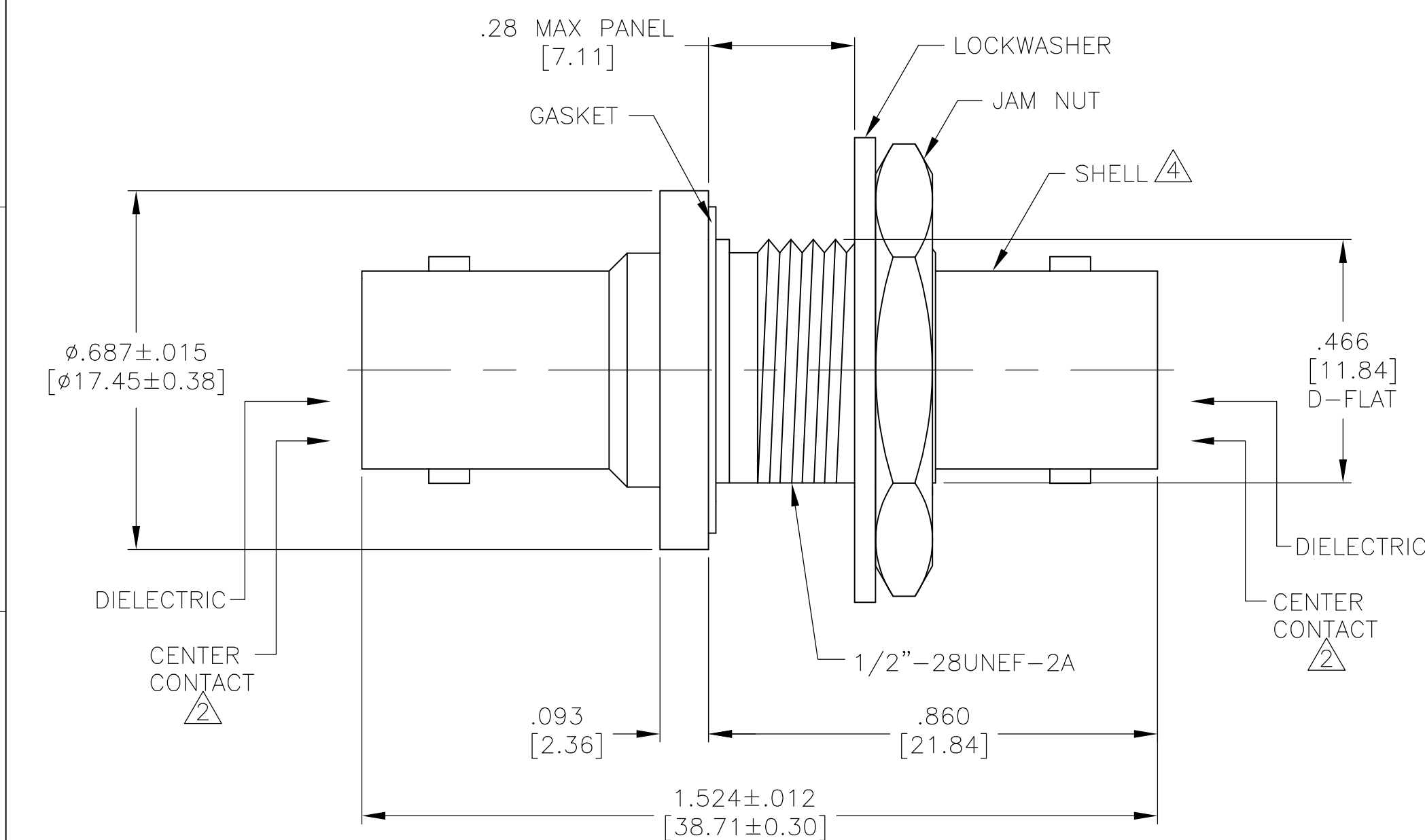

- 1 MATERIALS:
 DIELECTRIC: PTFE
 CENTER CONTACT: BERYLLIUM COPPER
 SHELL: BRASS
 GASKET: SILICONE
 LOCKWASHER: PHOSPHOR BRONZE
 JAM NUT: BRASS
- 2 SILVER PLATE PER QQ-S-365,
 5.08 um [.000200] MIN THICKNESS
- 3. PRODUCT MUST BE INTERMATEABLE
 PER MIL-C-39012
- 4 NICKEL PLATE PER QQ-N-290,
 2.54 um [.000100] MIN THICKNESS

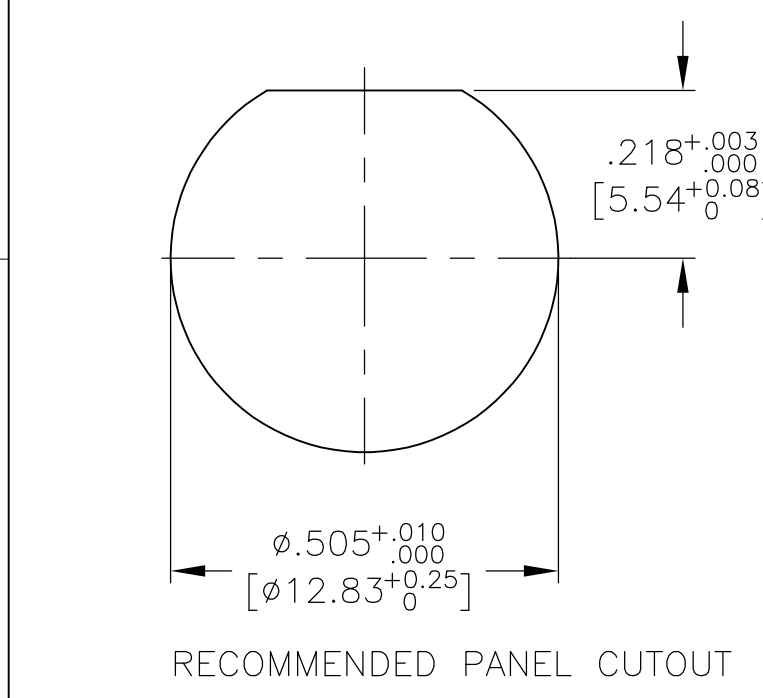

330024
 PART NUMBER

THIS DRAWING IS A CONTROLLED DOCUMENT.		DWN	M.E. COWHER	2-28-92	 TE Connectivity NAME ADAPTER, JACK, BHD, BNC	
DIMENSIONS: INCHES		CHK	M. PHILLIPS	3-2-92		
TOLERANCES UNLESS OTHERWISE SPECIFIED:		APVD	M.E. COWHER	3-3-92		
0 PLC ± - 1 PLC ± - 2 PLC ± .03 3 PLC ± .005 4 PLC ± - ANGLES ± -		PRODUCT SPEC	-	-		
MATERIAL	1	FINISH	2 4	APPLICATION SPEC	-	
CUSTOMER DRAWING		WEIGHT	-	SIZE	A3	
SCALE		4:1	CAGE CODE	00779	DRAWING NO	C-330024
SHEET		1 OF 1	RESTRICTED TO	-	REV	K1