



MICRO SWITCH™  
Heavy-Duty Limit Switches  
**HDLS Series**



# MICRO SWITCH™ HDLS Series Heavy-Duty Limit Switches

Honeywell Sensing and Control's MICRO SWITCH™ heavy-duty limit switches' modular construction allows for a wide variety of actuator styles, operating heads, and electrical circuitry options. The plug-in versions greatly reduce downtime on production lines with high actuation rates as replacement of the switch is accomplished in seconds. The base receptacle contains all the wiring and conduit connection while the switching component with operating head easily assembles to the base and is attached with two screws.

## *What makes our switches better?*

- Industry-leading breadth-of-product offering: HDLS standard, HDLS harsh-duty epoxy sealed, or the HDLS stainless steel
- NEMA 1, 3, 4, 4X, 6, 6P, 12, 13 and IP65/66/67 environmental sealing for demanding applications
- UL, CSA, CE, and CCC approvals for global use
- Sintered bronze bearing on 303 stainless steel operating shaft for enhanced mechanical life (50 million actuation cycles) and operational reliability
- All-metal drive train for consistent operating characteristics, even at high temperature. Lasts longer (without need for frequent adjustment) than drive trains with plastic parts
- Exclusive teller tab ensures proper torque. When it cannot be moved, the lever is tight enough to prevent slippage



RELIABILITY • DURABILITY  
MODULAR • GLOBAL

# Features and Benefits

## SEALED TO NEMA 1, 3, 4, 4X, 6, 6P, 12, 13; IP 65/66/67

MICRO SWITCH™ HDLS limit switch **NEMA/IP sealing** features twin shaft seals for an extra measure of protection. They are ideal for many applications with **demanding indoor and/or outdoor environments**, where they may be subjected to shock or vibration from equipment, temperature extremes, dust, splashing water, coolant, and/or hose-directed water.

### *Works the first time – every time*

## WITHSTANDS MANY TOUGH ENVIRONMENTS

Rugged, **corrosion-resistant zinc head and body** are phosphate treated and epoxy coated for indoor and outdoor applications. **Diaphragm seal** between head and body provides an extra measure of protection. Functions with exposure to severe temperatures, dust, dirt, grime, and caustic chemicals.

### *Rapid customization and design-in time*

## USED GLOBALLY

**Multiple connectivity options** for international applications, as well as global approvals. Large, existing installation base and channel allows for quick delivery worldwide. **UL, CSA, CE, and CCC** approvals.

## OPTIONAL SEALS

**Fluorosilicone seals** available for low temperature applications, and **fluorocarbon seals** available for chemically harsh environments and higher temperature applications.

## UNIQUE DESIGN FEATURES

Keyed head design for **secure head-to-body retention** with the head in any one of four positions 90° apart. Self-lifting pressure plate terminals **saves wiring time**.

## DESIGN FLEXIBILITY

Wide variety of actuators, switch options, and head styles for design flexibility. Rotary actuated heads are **field adjustable** for CW actuation, CCW actuation, or both to reduce inventory.

## EASILY CONTROLS LOW-VOLTAGE DC APPLICATIONS

Limit switches available with a choice of **silver or gold-plated contacts** to handle a variety of electrical load requirements.

## INTERCHANGEABLE

Plug-in and non plug-in bodies have identical operating characteristics and are **dimensionally interchangeable to reduce complexity**. Actuating levers for single and double pole, plug-in and non plug-in bodies provide same tracking and minimize inventory.

## Potential Applications



### **MACHINE TOOLS**

Determines part presence, machine side position/stops, gates and doors

### **AUTOMOTIVE MACHINE TOOLS**

Provides presence sensing on transfer machines, horizontal and vertical boring machines, stamping and forming equipment and automotive assembly line equipment

### **MATERIAL HANDLING**

Used to position automated vehicle wash systems, overhead doors, garbage truck bodies, cranes, intermodal container handlers, gantry cranes, commercial aircraft boarding bridge



### **OUTDOOR ELECTROMECHANICAL STRUCTURES**

End of travel indicator for equipment with moving components in harsh environments and remote locations, such as satellite and weather station arrays and solar energy harvesters

### **BALERS/COMPACTORS**

Used as door interlocks for indoor and outdoor applications

### **CONVEYORS**

Used for alignment/tracking, tensioning, and product/material presence

### **FOOD AND BEVERAGE**

Used for process control, and packaging

### **POWER PLANTS**

Used on conveyors, doors and gates

### **OFF-ROAD EQUIPMENT**

Senses position of large components on wheeled or track equipment, motorized railroad switch, and rail locomotives

### **AGRICULTURAL EQUIPMENT**

Grain handling and livestock equipment

### **VALVES**

Indicates closed and/or open position

### **TRANSPORTATION HUBS**

Commercial aircraft boarding bridge, commercial aircraft ground support equipment, intermodal container handlers, gantry cranes, shipboard conveyors, door/hatch position & valve position, railroad locomotives and rail maintenance equipment





# MICRO SWITCH™ Heavy-Duty Limit Switches

Figure 1. MICRO SWITCH™ HDLS SERIES FEATURES AND OPTIONS



# HDLS Series

**Table 1. Specifications**

Characteristic	Parameter		
Product type	MICRO SWITCH™ heavy-duty limit switches		
Acutators	Side plunger - adjustable Side roller plunger Top plunger - adjustable Top rotary Wobble - coil spring	Side plunger - pin Side rotary Top plunger - pin Wobble - cable Wobble - plastic rod	Side plunger maintained - pin Side rotary maintained Top roller plunger Wobble - cat whisker Wobble - spring wire
Circuitry	1NC 1NO SPDT snap action, double break 2NC 2NO DPDT center neutral, snap action, double break 2NC 2NO DPDT snap action, double break 2NC 2NO DPDT sequential, snap action, double break		
Electrical	10 A thermal Single and double pole: AC15 A600; DC13 R300 (see table on page 8)		
Housing material	Zinc die-cast with an electrostatic epoxy coating		
Termination types	0.5 in - 14NPT conduit PG 13,5 conduit 4-pin mini-style connector 6 ft cable	0.75 in - 14NPT conduit 20 mm conduit 5-pin mini-style connector Manifold mounting	12 ft cable 4-pin micro-style connector 9-pin mini-style connector
Housing type	HDLS Plug-in, HDLS Non-Plug-in		
Sealing	IP65/66/67; NEMA 1, 3, 4, 4X, 6, 6P, 12, 13		
Operating temperature	-12 °C to 121 °C [10 °F to 250 °F]; optional: -40 °C to 121 °C [-40 °F to 250 °F]		
Agency approvals and standards	UL, CE, CSA, CCC		
UNSPSC code	302119		
UNSPSC commodity	302119 Switches and controls and relays		
Sealed	Industrial		

# MICRO SWITCH™ Heavy-Duty Limit Switches

## MICRO SWITCH™ HDLS SERIES NOMENCLATURE

LS	A		1A			1	-					
Switch Type	Heads		Body/Basic Switch Codes			Modification Codes		Wobble Actuator				
<b>HDLS Series Heavy-Duty Limit Switch</b>  * 3 or 4 after the "LS" indicates special metric conduit threads: 3 = PG 13,5 4 = 20 mm	<b>A</b> Side rotary, momentary	<b>L</b> Side rotary, sequential	Plug-in Single Pole			Plug-in Double Pole		Non-plug-in Double Pole		<b>A</b> 4-pin mini-style	<b>PA</b> 5-conductor STOOW-A cable, 8 ft	<b>7A</b> Wobble, plastic
	<b>B</b> Top rotary, momentary	<b>M</b> Side rotary, center neutral	<b>1A</b> Standard switch	<b>2B</b> Standard switch	<b>4L</b> Standard switch	<b>B</b> 5-pin mini-style	<b>XA</b> 9-conductor STOOW-A cable, 8 ft	<b>7M</b> Wobble, wire				
	<b>C</b> Top plunger, plain	<b>N</b> Side rotary, maintained	<b>1E</b> Gold contacts	<b>2C</b> Sequential	<b>4M</b> Sequential	<b>C</b> 5-conductor STOW-A cable, 6 ft	<b>PB</b> 5-conductor STOOW-A cable, 30 ft	<b>7N</b> Wobble, cable				
	<b>D</b> Top roller plunger	<b>P</b> Side rotary, momentary, low pretravel	<b>1G</b> Gold contacts, manifold mount	<b>2D</b> Center neutral	<b>4N</b> Center neutral	<b>E</b> 4-conductor SJTOW-A cable, 6 ft	<b>1</b> Clockwise head rotation	<b>8A</b> Cat whisker, 5.5 in steel				
	<b>E</b> Side plunger plain, momentary	<b>R</b> Side rotary, momentary, low torque	<b>1H</b> Low force	<b>2R</b> 120 V neon indicator	<b>4S</b> Standard switch golf contacts	<b>J</b> 8-pin mini-style	<b>2</b> Counterclockwise head rotation	<b>8B</b> Cat whisker, 7.5 in steel				
	<b>F</b> Side plunger roller, momentary	<b>S</b> Side rotary, gravity return extr. low torque	<b>5A</b> 120 V neon indicator	<b>2S</b> Standard switch golf contacts	<b>4T</b> Sequential, gold contacts	<b>M</b> 9-conductor STOOW-A cable, 6 ft	<b>3</b> Head assembled with actuator to right side	<b>8C</b> Coil spring, 5.5 in				
	<b>G</b> Side plunger plain, maintained	<b>T</b> Side rotary, momentary, extr. low torque	<b>8A</b> 240 V neon indicator	<b>2T</b> Sequential, gold contacts	<b>4U</b> Center neutral, gold contacts	<b>P</b> 5-conductor STOOW-A cable, 12 ft	<b>4</b> Head assembled with actuator to left side	<b>8D</b> Cat whisker, plastic				
	<b>H</b> Side rotary, momentary, low pretravel & torque	<b>U</b> Side rotary, momentary, 5" max. pretravel	<b>9A</b> 24 V LED indicator	<b>2U</b> Center neutral, gold contacts	<b>7L</b> Standard switch, 1/2 in conduit	<b>R</b> 9-pin mini-style	<b>5</b> Head assembled with actuator to mounting surface					
	<b>J</b> Wobble stick	<b>V</b> Top plunger, adjustable	Non-plug-in Single Pole	<b>6B</b> Standard switch, 1/2 in conduit	<b>7M</b> Sequential, 1/2 in conduit	<b>S</b> 5-pin micro-style	<b>6</b> Roller perpendicular to mounting surface					
	<b>K</b> Cat whisker	<b>W</b> Side plunger, momentary, adjustable	<b>3K</b> Standard switch	<b>6C</b> Sequential, 1/2 in conduit	<b>7N</b> Center neutral, 1/2 in conduit	<b>X</b> 9-conductor STOOW-A cable, 12 ft	<b>7</b> Indicator light wired to normally closed circuit					
				<b>6D</b> Center neutral, 1/2 in conduit	<b>7S</b> Stnd. switch, gold contacts, 1/2 in conduit	<b>BB</b> 3-foot mini-style pigtail, single pole	<b>8</b> Roller on side plunger in vertical position					
				<b>6R</b> 120 V neon indicator, 1/2 in conduit	<b>7T</b> Sequential, gold contacts, 1/2 in conduit	<b>DD</b> 4-pin micro-style with jumper						
				<b>6S</b> Stnd. switch, gold contacts, 1/2 in conduit	<b>7U</b> Center neutral, gold contacts, 1/2 in conduit							
			<b>6T</b> Sequential, gold contacts, 1/2 in conduit									
			<b>6U</b> Center neutral, gold contacts, 1/2 in conduit									

**NOTE:** Not all combinations of model codes are available. Please contact your local Honeywell provider for assistance.

# HDLS Series

## ASSEMBLY MODIFICATIONS • ROTARY

Momentary action rotary switches can be furnished in other than the normal assembled conditions. To specify modifications, add the numbers shown below to the catalog listings. Modification number suffixes are:

- 1 Clockwise actuation only
- 2 Counterclockwise actuation only
- 3 Shaft to right of switch front
- 4 Shaft to left of switch front
- 5 Shaft to back of switch
- 7 Indicator light wired to NC circuit

### For example,

Catalog listing LSA1A**23** is an LSA1A switch adjusted for counterclockwise actuation only. The operating shaft is to the right side of the switch when viewing it from the front (label side). No lever.

Catalog listing LSA8A**7** is an LSA8A switch with the 240 volt indicator light wired to the NC circuit. No lever.

## PLUNGER ASSEMBLY MODIFICATIONS

Add the following modification numbers to the catalog listing in the plunger switch:

- 3 Side plunger to right of switch front
- 4 Side plunger to left of switch front
- 5 Side plunger to back of switch
- 6 Roller on top plungers perpendicular to mounting surface
- 7 Light on indicator versions wired to NC circuit
- 8 Roller on side plungers in vertical position

### For example,

Catalog listing LSF1A**3** is an LSF1A switch with the side roller plunger to the right side.

## PLUG-IN VS. NON-PLUG-IN MODELS

Honeywell HDLS limit switches are offered in two styles: non-plug-in design and plug-in design. With plug-in construction, the wiring and conduit connection is made to the base receptacle. This feature reduces downtime as the plug-in unit can be removed and replaced without disconnecting the wiring or conduit connections to the switch.

## MICRO SWITCH™ HDLS SERIES ELECTRICAL RATINGS:

### 10 A CONTINUOUS CARRY

### AC VOLTS; PILOT DUTY: AC15, A600/B600

Electrical Rating	Circuitry	Vac	Amps at 0.35 Power Factor Make	Amps at 0.35 Power Factor Break
A* AC15, A600	SPDT DPDT	120	60	6
		240	30	3
		480	15	1.5
		600	12	1.2
B AC15, B600	Δ	120	30	3
		240	15	1.5
		480	7.5	0.75
		600	6	0.60

Δ Gravity return (Model LSS..) and extra-low torque (Model LST..)

## MICRO SWITCH™ HDLS SERIES ELECTRICAL RATINGS:

### DC VOLTS; PILOT DUTY: DC13, R300

Electrical Rating	Circuitry	Vdc	Make & Break Amps Inductive	Make & Break Amps Resistive
A, B*	SPDT DPDT	120	0.25	0.8
		240	0.15	0.4

\* For switches with an indicator light, use only at voltage stated for indicator light.

MICRO SWITCH™ HDLS limit switches are capable of the following low voltage dc loads

Circuitry	Vdc	Amps Inductive	Amps Resistive
SPDT	24	10	10
DPDT	24	10	10





# MICRO SWITCH™ Heavy-Duty Limit Switches

## MICRO SWITCH™ HDLS SERIES OPERATING HEADS

**SIDE ROTARY:** Available levers provide greater versatility. Heads may be positioned with shaft on any side. All are momentary action except maintained head (LSN Series).



**LSA - Standard:** 60° minimum overtravel, 15° maximum pretravel, 5° (single pole) and 7° (double pole) maximum differential travel. Operating temperature range from -12 °C to 121 °C [10 °F to 250 °F].\*

**LSR - Low operating torque:** 60° minimum overtravel, 15° maximum pretravel, 0.19 Nm [1.7 in lb] maximum operating torque. Operating temperature range from -1 °C to 121 °C [250 °F to 250 °F].\*

**LSN - Maintained contact:** Maintained on counterclockwise rotation and reset on clockwise rotation, and vice versa. Operating temperature range from -1 °C to 121 °C [30 °F to 250 °F].

**LSP - Low differential:** 68° minimum overtravel, 7° maximum pretravel, 3° (single pole) and 4° (double pole) maximum differential travel. Operating temperature range from -12 °C to 121 °C [10 °F to 250 °F].\*

**LSH - Low torque, low differential travel:** 68° minimum overtravel. Features low operating torque and narrow differential travel. Operating temperature range from -1 °C to 121 °C [30 °F to 250 °F].\*

**LSU - Low pretravel:** 5° max. pretravel, 70° min. overtravel, and a second step of 18° max. Operating temperature range from -12 °C to 121 °C [10 °F to 250 °F].\*

**LSL - Sequence action:** 48° minimum overtravel. Delayed action between operation of two poles. Operating temperature range from -12 °C to 121 °C [10 °F to 250 °F].\*

**LSM - Center neutral:** 53° minimum overtravel. One set of contacts operates on the clockwise rotation, and another set on the counterclockwise rotation. Operating temperature range from -1 °C to 121 °C [30 °F to 250 °F].\*

**LST - Momentary action with extra low torque:** 12 in oz of operating and full travel torque with momentary action. Operating temperature range from -12 °C to 121 °C [10 °F to 250 °F].\*

**LSS - Gravity return:** Has no return spring mechanism so weight of the lever must provide the return force. Extremely light operating torque (5 in oz max.) is useful in conveyor applications and can be operated by small or lightweight objects. Operating temperature range from -1 °C to 121 °C [30 °F to 250 °F].\*

**TOP ROTARY:** Available levers provide greater versatility. Heads may be positioned with shaft on any side. All are momentary action except maintained head.



**LSB:** With 100° minimum overtravel. Various levers that fit side rotary shafts may be used on the top rotary shaft. Switch is ideal when increased overtravel is required. Momentary action. Standard operating temperature range from -1 °C to 121 °C [30 °F to 250 °F].\*

**TOP PLUNGERS:** Available with 4,83 mm [0.19 in] minimum overtravel. Top pin plungers are offered in pin plunger, an adjustable plunger, and a roller plunger. Standard temperature range of -12 °C to 93 °C [10 °F to 200 °F].



**LSC - Top pin plunger:** A corrosion-resistant steel plunger for in-line actuating motion. Oil-tight seals on plunger and between the operating head and housing keep out coolant, dust, and chips. Momentary action.



**LSD - Top roller plunger:** A corrosion-resistant steel roller and plunger that is adjustable to 90° angles to accept cam or slide operation from any of two directions. Boot seal on the plunger. Momentary action



**LSV - Adjustable top pin plunger:** Provides easy application and saves on installation time. The operating points of the switch can be adjusted from 52,8 mm to 59,3 mm [2.085 in to 2.335 in]. Seals are the same as the pin plunger. Momentary action.

\* (Fluorocarbon seals are preferred for temperatures above 93 °C [200 °F]).

# HDLS Series

## MICRO SWITCH™ HDLS SERIES OPERATING HEADS

**SIDE PLUNGERS:** Available with 4,83 mm [0.19 in] minimum overtravel. Side plungers are offered in plain plunger, an adjustable plain plunger, a roller plunger, and a maintained plunger. Standard temperature range of -12 °C to 93 °C [10 °F to 200 °F].

	<p><b>LSE - Side pin plunger:</b> For actuating motion inline with the plunger travel. Actuating head may be faced in any of four positions, 90° apart. A boot seal on the plunger and a gasket seal between the head and housing keep out coolant, dust, and chips. Momentary action.</p>		<p><b>LSW - Adjustable side pin plunger:</b> Has the same features of the side plain plunger plus the means to adjust the operating points of the switch from 41 mm to 47,4 mm [1.615 in to 1.865 in]. Momentary action.</p>
	<p><b>LSF - Side roller plunger:</b> Fits close quarters under cams and slides. The head may be faced in any of four positions, 90° apart. <u>The roller can be turned vertical or horizontal to the switch.</u> Boot seal on plunger. Momentary action.</p>		<p><b>LSG - Maintained contact side pin plunger:</b> Offers a maintained contact on actuation of the switch. A reverse motion of the plunger resets the switch. Sealing is the same as other side plunger actuation heads. Operating temperature range is -1 °C to 93 °C [30 °F to 200 °F].</p>

**WOBBLE LEVER ACTUATING HEADS:** Heads come with either a spring wire, Delrin® plastic rod, or steel cat whisker. Any movement of the lever (except pull) will actuate the switch. Standard temperature range of -12 °C to 93 °C [10 °F to 200 °F].

				
<p><b>LSJ1A-7M - Spring wire:</b> 300 Series SST wire may be formed for special applications.</p>	<p><b>LSJ1A-7N - Flexible actuator:</b> Designed with a tin-plated cable.</p>	<p><b>LSK1A-8C - Coil spring:</b> Designed with a 300 Series SST coil spring.</p>	<p><b>LSJ1A-7A - Plastic rod:</b> Recommended where possible scratching or marring by the actuator is to be avoided.</p>	<p><b>LSK1A-8A - Cat whisker:</b> 300 Series SST actuator designed for low operating force applications.</p>

\*(Fluorocarbon seals are preferred for temperatures above 93 °C [200 °F]).

# MICRO SWITCH™ Heavy-Duty Limit Switches

## SPECIAL OPTIONS

### HIGH TEMPERATURE/CHEMICAL RESISTANT SWITCHES

Completely fluorocarbon (FC)-sealed switches have a full FC body gasket covering the switch cavity. Rotary types have an extra FC seal on the operating shaft, while plunger versions have FC boot seals. They are for use in many applications where the environment includes fire-resistant synthetic fluids. In addition to most all fluids, the FC-sealed switches may be used with such industrial fluids such as Cellulube, Fyrquell, Houghto-Safe, Pydraul, and other special cutting and hydraulic fluids. The additional FC seals also promote longer operating life for rotary-actuated HDLS switches in applications where the temperatures are normally -12 °C to 121 °C [10 °F to 250 °F]. If pre-wired with cable, then temperature limits are 105 °C [221 °F] dry and 60 °C [140 °F] wet.

To order, insert the additional letters **Y** and **C** in the appropriate places in the standard catalog listing, as shown below:

<b>LSA1A</b>	standard, side-rotary plug-in switch
<b>LSYA1A</b>	completely FC-sealed version of LSA1A

### LOW TEMPERATURE SWITCHES

All forms of HDLS limit switches are also available in low-temperature construction. Design features include fluorosilicone diaphragm, shaft seals, and external booth seal (where applicable). If pre-wired with a cable, low temperature limits are -10 °C [14 °F] flex and -30 °C [-22 °F] non-flex.

To order, insert the additional letters **Y** and **B** in the appropriate places in the standard catalog listing, as shown below:

<b>LSA1A</b>	standard, side-rotary plug-in switch
<b>LSYAB1A</b>	low-temperature version of LSA1A

### CONDUIT OPENINGS

For conduit openings other than 1/2-NPT and 3/4-NPT, substitute the following after LS in the catalog listing:

**LS3** PG13,5

**LS4** 20 mm

<b>LSA1A</b>	side rotary with 1/2-14 NPT conduit
<b>LS4A1A</b>	side rotary with 20 mm conduit

## TEMPERATURE LIMITS

	Standard HDLS				Low Temperature HDLS (Fluorosilicone Sealed): Y B				High Temperature HDLS (Fluorocarbon Sealed)*: Y C		
	Low Limit		High Limit		Low Limit		High Limit		Low Limit		High Limit
	-12 °C [10 °F]	-1 °C [30 °F]	93 °C [200 °F]	121 °C [250 °F]	-40 °C [-40 °F]	-29 °C [-20 °F]	93 °C [200 °F]	121 °C [250 °F]	-12 °C [10 °F]	-1 °C [30 °F]	121 °C [250 °F]
LSA - Side Rotary Momentary	X			X	X			X	X		X
LSB - Top Rotary		X		X		X		X		X	X
LSC - Top Plain Plunger	X		X		X		X		X		X
LSD - Top Roller Plunger	X		X		X		X		X		X
LSE - Side Plain Plunger	X		X		X		X		X		X
LSF - Side Roller Plunger	X		X		X		X		X		X
LSG - Side Plunger, Maintained		X	X			X	X			X	X
LSH - Side Rotary, Low PT, Low Torque		X		X		X		X		X	X
LSJ - Wobble Stick	X		X		X			X	X		X
LSK - Cat Whisker	X		X			X		X	X		X
LSL - Side Rotary, Sequence	X			X	X			X	X		X
LSM - Side Rotary, Center Neutral		X		X	X			X		X	X
LSN - Side Rotary, Maintained		X		X		X		X		X	X
LSP - Side Rotary, Low Pretravel	X			X	X			X	X		X
LSR - Side Rotary, Low Torque		X		X		X		X		X	X
LSU - 5° Low Pretravel	X			X	X			X	X		X
LSV - Top Adjustable Plunger	X		X		X		X		X		X
LSW - Side Adjustable Plunger	X		X		X		X		X		X

\* For HDLS application wherein the upper temperature limit is normally above 93 °C [200 °F], much longer switch life can be obtained by using completely fluorocarbon-sealed switches rather than standard HDLS.

## FACTORY SEALED PRE-WIRED LIMIT SWITCHES

### Features

- Pre-wired with 6 ft STOOW-A cable or other 4, 5, or 9-pin connectors (other lengths available)
- Wire entry area completely factory sealed
- (Cable version) NEMA 1, 6, 6P, 12; IP67
- (Connector version) NEMA 1, 6, 6P, 12, 13; IP67

### How to order:

To order factory sealed switches, add the modification codes shown below to the standard HDLS listings:

Circuitry	Cable	1/2 in connector style
SPDT	<b>C</b>	<b>A</b> (4-pin mini-style) <b>B</b> (5-pin mini-style) <b>DD</b> (4-pin micro-style)
DPDT	<b>M</b>	<b>R</b> (9-pin mini-style)

Examples:

LSA1A**C** = LSA1A with 6 feet of 5-conductor STOW-A cable

LSJ2B**M**-7N = LSJ2B-7N with 6 feet of 9-conductor STOOW-A cable

LSA1A**B** = LSA1A with a 5-pin mini-style connector

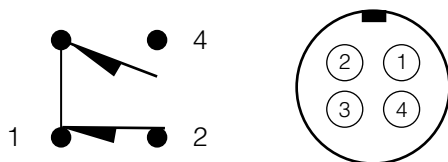
LSA1A**DD** = LSA1A with a 4-pin micro-style connector

**NOTE:** Connector versions available with 1/2 in conduit only.

### WIRING DIAGRAM (STYLE A)



### WIRING DIAGRAM (STYLE DD)

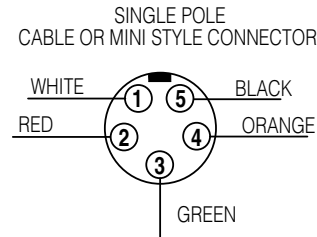


Pin 3 not connected

## WIRING DIAGRAMS (STYLES B&G)

Connectors = Numbers (mini-style)

Cables = Colors



Single-Pole Circuitry

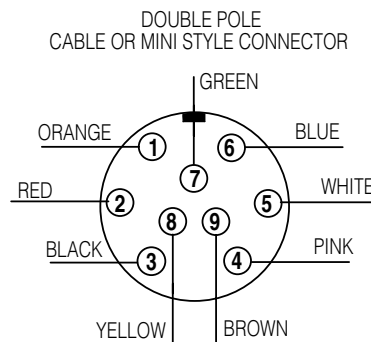


3 = Ground

### Electrical Ratings: Connector Versions

Mini	600 VAC, 7A
Micro	300 VAC, 3A

## WIRING DIAGRAMS (STYLES M&R)



Double-Pole Circuitry



7 = Ground



# MICRO SWITCH™ Heavy-Duty Limit Switches

## SIDE ROTARY • MICRO SWITCH™ HDLS SERIES ORDER GUIDE/RECOMMENDED LISTINGS



	Standard (LSA)		Low Differential (LSP)		5° Pretravel (LSU)	
Description	Standard		Low pretravel & low differential travel		Low pretravel	
	SPDT	DPDT	SPDT	DPDT	SPDT	DPDT
<b>Contact closed</b> ■ <b>Contact open</b> □						
<b>Pretravel</b>	15° max.	15° max.	9° max.	9° max.	5° max.	5° max.
<b>Different. travel</b>	5° max.	7° max.	3° max.	4° max.	3° max.	4° max.
<b>Overtravel</b>	60° min.	60° min.	66° min.	66° min.	70° min.	70° min.
<b>Oper. torque</b>	0,45 Nm [4 in-lb] max.		0,45 Nm [4 in-lb] max.		0,45 Nm [4 in-lb] max.	
<b>Action</b>	CW & CCW (Momentary)					
<b>Op. temp range</b> <sup>3</sup>	-12 °C to 121 °C [10 °F to 250 °F] (for low temp, high temp, or preleaded versions, see pages 11-12)					

Circuitry	Contacts	Body Style <sup>2</sup>	Conduit (NPT)	Options			
	Silver	Plug-in	0.5 in		<b>LSA1A</b>	<b>LSP1A</b>	<b>LSU1A</b>
	Gold <sup>4</sup>	Plug-in	0.5 in		<b>LSA1E</b>	<b>LSP1E</b>	<b>LSU1E</b>
	Silver	Plug-in	0.5 in	120 V Ind. lite <sup>1</sup>	<b>LSA5A</b>	<b>LSP5A</b>	<b>LSU5A</b>
	Silver	Plug-in	0.5 in	240 V Ind. lite <sup>1</sup>	<b>LSA8A</b>	<b>LSP8A</b>	<b>LSU8A</b>
	Silver	Plug-in	0.5 in	24 V LED 1.5 mA max. auto polarity <sup>1</sup>	<b>LSA9A</b>	<b>LSP9A</b>	<b>LSU9A</b>
	Silver	Non-plug-in	0.5 in		<b>LSA3K</b>	<b>LSP3K</b>	<b>LSU3K</b>
	Silver	Plug-in	0.75 in		<b>LSA2B</b>	<b>LSP2B</b>	<b>LSU2B</b>
	Gold <sup>4</sup>	Plug-in	0.75 in		<b>LSA2S</b>	-	-
	Silver	Plug-in	0.5 in		<b>LSA6B</b>	<b>LSP6B</b>	<b>LSU6B</b>
	Gold <sup>4</sup>	Plug-in	0.5 in		<b>LSA6S</b>	-	-
	Silver	Plug-in	0.75 in	120 V Ind. lite <sup>1</sup>	<b>LSA2R</b>	<b>LSP2R</b>	<b>LSU2R</b>
	Silver	Non-plug-in	0.75 in		<b>LSA4L</b>	<b>LSP4L</b>	<b>LSU4L</b>
	Silver	Non-plug-in	0.5 in		<b>LSA7L</b>	<b>LSP7L</b>	<b>LSU7L</b>

<sup>1</sup> Use at voltage indicated for light. Wired to NO circuit. Upper temperature limit for lighted units is 93 °C [200 °F]

<sup>2</sup> Plug-in listings include base receptacle

<sup>3</sup> Completely fluorocarbon sealed switches are preferred for use in temperatures above 93 °C [200 °F]

<sup>4</sup> Gold-plated contacts

NOTE: Same polarity each pole.

To order a fluorocarbon sealed switch, insert the letters **Y** and **C** into the catalog listing as follows. The LSA1A limit switch is changed to a LSY**AC**1A limit switch.

To order a low temperature, fluorosilicone sealed switch, insert the letters **Y** and **B** into the catalog listing as follows. The LSA1A limit switch is changed to a LSY**AB**1A limit switch.

# HDLS Series

## SIDE ROTARY • MICRO SWITCH™ HDLS SERIES ORDER GUIDE/RECOMMENDED LISTINGS



Description	Low Torque (LSR)		Low Diff., Low Torque (LSH)	
	Low operating torque		Low pretravel and low torque	
	SPDT	DPDT	SPDT	DPDT
	Snap Action 1NO/1NC 	Snap Action 2NO/2NC 	Snap Action 1NO/1NC 	Snap Action 2NO/2NC 
	Contact closed ■ Contact open □			
<b>Pretravel</b>	15° max.	15° max.	9° max.	9° max.
<b>Different. travel</b>	5° max.	7° max.	3° max.	4° max.
<b>Overtravel</b>	60° min.	60° min.	66° min.	66° min.
<b>Oper. torque</b>	0,19 Nm [1.7 in-lb] max.		0,19 Nm [1.7 in-lb] max.	
<b>Action</b>	CW & CCW (Momentary)			
<b>Op. temp range<sup>3</sup></b>	-1 °C to 121 °C [30 °F to 250°F] (for low temp, high temp, or preloaded versions, see pages 11-12)			

Circuitry	Contacts	Body Style <sup>2</sup>	Conduit (NPT)	Options		
<b>SPDT</b> 	Silver	Plug-in	0.5 in		<b>LSR1A</b>	<b>LSH1A</b>
	Gold <sup>4</sup>	Plug-in	0.5 in		<b>LSR1E</b>	<b>LSH1E</b>
	Silver	Plug-in	0.5 in	120 V Ind. lite <sup>1</sup>	<b>LSR5A</b>	<b>LSH5A</b>
	Silver	Plug-in	0.5 in	240 V Ind. lite <sup>1</sup>	<b>LSR8A</b>	<b>LSH8A</b>
	Silver	Plug-in	0.5 in	24 V LED 1.5 mA max. auto polarity <sup>1</sup>	<b>LSR9A</b>	<b>LSH9S</b>
	Silver	Non-plug-in	0.5 in		<b>LSR3K</b>	<b>LSH3K</b>
<b>DPDT</b> 	Silver	Plug-in	0.75 in		<b>LSR3B</b>	<b>LSH2B</b>
	Silver	Plug-in	0.5 in		<b>LSR6B</b>	<b>LSH6B</b>
	Silver	Plug-in	0.75 in	120 V Ind. lite <sup>1</sup>	<b>LSR2R</b>	<b>LSH2R</b>
	Silver	Non-plug-in	0.75 in		<b>LSR4L</b>	<b>LSH4L</b>
	Silver	Non-plug-in	0.5 in		<b>LSR7L</b>	<b>LSH7L</b>

<sup>1</sup> Use at voltage indicated for light. Wired to NO circuit. Upper temperature limit for lighted units is 93°C [200 °F]

<sup>2</sup> Plug-in listings include base receptacle

<sup>3</sup> Completely fluorocarbon sealed switches are preferred for use in temperatures above 93 °C [200 °F]

<sup>4</sup> Gold-plated contacts

NOTE: Same polarity each pole.

To order a fluorocarbon sealed switch, insert the letters **Y** and **C** into the catalog listing as follows. The LSA1A limit switch is changed to a LSY**AC**1A limit switch.

To order a low temperature, fluorosilicone sealed switch, insert the letters **Y** and **B** into the catalog listing as follows. The LSA1A limit switch is changed to a LSY**AB**1A limit switch.

# MICRO SWITCH™ Heavy-Duty Limit Switches

## SIDE ROTARY • MICRO SWITCH™ HDLS SERIES ORDER GUIDE/RECOMMENDED LISTINGS



	Maint. Contact (LSQ)	Maint. Contact (LSN)	Center Neutral (LSM)	Sequence Action (LSL)
<b>Description</b>	Maint. 360° Alt. Action	Maintained, 2-pos <sup>1,2</sup> . Std.	Center Neutral (Pole 1 operates CCW; Pole 2 operates CW)	Sequential (Pole 1 operates before Pole 2, either CW, CCW, or both)
	<b>SPDT</b>	<b>SPDT DPDT</b>	<b>DPDT</b>	<b>DPDT</b>
<b>Contact closed</b> ■				
<b>Contact open</b> □				
<b>Pretravel</b>	65° max.	65° max.	18° max.	Pole 1: 15° Pole 2: add'l 10°
<b>Different. travel</b>	40° max.	40° max.	10° max.	each pole: 5°
<b>Overtravel</b>	20° min.	20° min.	57° min.	48° min.
<b>Oper. torque</b>	0,45 Nm [4 in-lb]		0,45 Nm [4 in-lb]	0,45 Nm [4 in-lb]
<b>Action</b>	Maintained		CW & CCW (Momentary)	
<b>Op. temp range<sup>6</sup></b>	-1 °C to 121 °C [30 °F to 250°F] (for low temp, high temp, or preleaded versions, see page 11-12)			-12 °C to 121 °C [10 °F to 250°F] (for low temp, high temp, or preleaded versions, see page 11-12)

Circuitry	Contacts	Body Style <sup>5</sup>	Conduit (NPT)	Options				
	Silver	Plug-in	0.5 in		<b>LSQ300</b>	<b>LSN1A</b>		
	Gold <sup>3</sup>	Plug-in	0.5 in		-	<b>LSN1E</b>		
	Silver	Plug-in	0.5 in	120 V Ind. lite <sup>4</sup>	-	<b>LSN5A</b>		
	Silver	Plug-in	0.5 in	240 V Ind. lite <sup>4</sup>	-	<b>LSN8A</b>		
	Silver	Non-plug-in	0.5 in		-	<b>LSN3K</b>		
	Silver	Plug-in	0.75 in		-	<b>LSN2B</b>	<b>LSM2D</b>	<b>LSL2C</b>
	Silver	Plug-in	0.5 in		-	<b>LSN6B</b>	<b>LSM6D</b>	<b>LSL6C</b>
	Gold <sup>3</sup>	Plug-in	0.5 in		-	-	<b>LSM6U</b>	-
	Silver	Non-plug-in	0.75 in		-	<b>LSN4L</b>	<b>LSM4N</b>	<b>LSL4M</b>
	Silver	Non-plug-in	0.5 in		-	<b>LSN7L</b>	<b>LSM7N</b>	<b>LSL7M</b>

<sup>1</sup> Mechanical trip before electrical trip.

<sup>2</sup> Total travel is approximately 80° max. Maintained contact switch normally used with LSZ53 yoke actuator.

<sup>3</sup> Gold-plated contacts

<sup>4</sup> Use at voltage indicated for light. Wired to NO circuit. Upper temperature limit for lighted units is 93°C [200 °F].

<sup>5</sup> Plug-in listings include base receptacle

<sup>6</sup> Completely fluorocarbon-sealed switches are preferred for temperatures above 93 °C [200 °F].

NOTE: Same polarity each pole.

To order a fluorocarbon sealed switch, insert the letters **Y** and **C** into the catalog listing as follows. The LSA1A limit switch is changed to a LSYAC1A limit switch.

To order a low temperature, fluorosilicone sealed switch, insert the letters **Y** and **B** into the catalog listing as follows. The LSA1A limit switch is changed to a LSYAB1A limit switch.

# HDLS Series

Figure 2. MICRO SWITCH™ HDLS side rotary (single pole) dimensions

## SPDT Plug-in (mm[in])

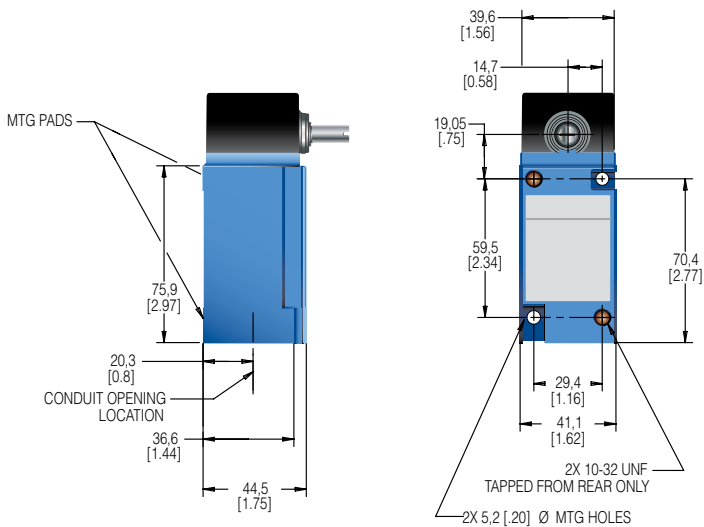


Figure 3. MICRO SWITCH™ HDLS side rotary (double pole) dimensions

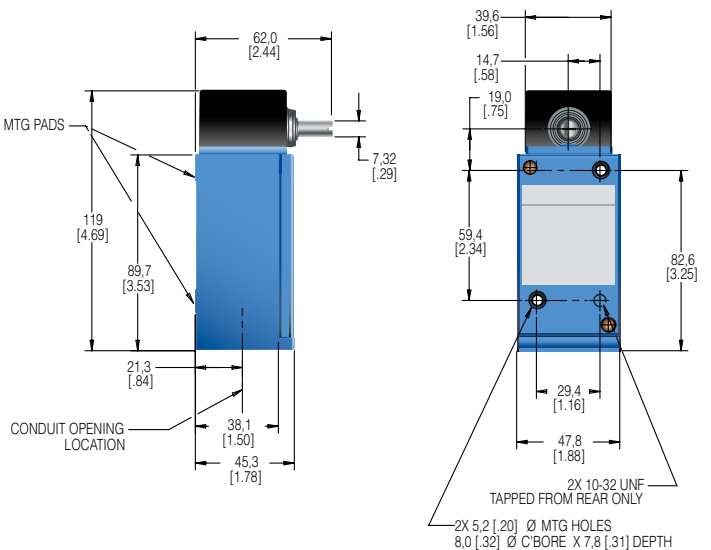
## DPDT Plug-in (mm[in])



## SPDT Non-plug-in (mm[in])



## DPDT Non-plug-in (mm[in])





# MICRO SWITCH™ Heavy-Duty Limit Switches

## TOP ROTARY • MICRO SWITCH™ HDLS SERIES ORDER GUIDE/RECOMMENDED LISTINGS



		Top Rotary (LSB)	
Description	Increased overtravel (100° min.). Uses same levers as side rotary		
	SPDT	DPDT	
	Snap Action 1NO/1NC 	Snap Action 2NO/2NC 	
	Contact closed ■ Contact open □		
Pretravel	25° max.	25° max.	
Different. travel	10° max.	12° max.	
Overtravel	110° min.	110° min.	
Oper. torque	0,28 Nm [2.5 in lb] max.		
Op. temp range <sup>3</sup>	-12 °C to 121 °C [10 °F to 250 °F] (for low temp, high temp, or preloaded versions, see pages 11-12)		

Circuitry	Contacts	Body Style <sup>2</sup>	Conduit (NPT)	Options		
	Silver	Plug-in	0.5 in		<b>LSB1A</b>	-
	Gold <sup>4</sup>	Plug-in	0.5 in		<b>LSB1E</b>	-
	Silver	Plug-in	0.5 in	120 V Ind. lite <sup>1</sup>	<b>LSB5A</b>	-
	Silver	Plug-in	0.5 in	240 V Ind. lite <sup>1</sup>	<b>LSB8A</b>	-
	Silver	Plug-in	0.5 in	24 V LED 1.5 mA max. auto polarity <sup>1</sup>	<b>LSB9A</b>	-
	Silver	Non-plug-in	0.5 in		<b>LSB3K</b>	-
	Silver	Plug-in	0.75 in		-	<b>LSB2B</b>
	Silver	Plug-in	0.5 in		-	<b>LSB6B</b>
	Silver	Plug-in	0.75 in	120 V Ind. lite <sup>1</sup>	-	<b>LSB2R</b>
	Silver	Non-plug-in	0.75 in		-	<b>LSB4L</b>
	Silver	Non-plug-in	0.5 in		-	<b>LSB7L</b>
	Silver	Non-plug-in	0.5 in		-	

<sup>1</sup> Use at voltage indicated for light. Wired to NO circuit. Upper temperature limit for lighted units is 93 °C [200 °F]

<sup>2</sup> Plug-in listings include base receptacle

<sup>3</sup> Completely fluorocarbon sealed switches are preferred for use in temperatures above 93 °C [200 °F]

<sup>4</sup> Gold-plated contacts

NOTE: Same polarity each pole.

To order a fluorocarbon sealed switch, insert the letters **Y** and **C** into the catalog listing as follows. The LSA1A limit switch is changed to a LSY**AC**1A limit switch.

To order a low temperature, fluorosilicone sealed switch, insert the letters **Y** and **B** into the catalog listing as follows. The LSA1A limit switch is changed to a LSY**AB**1A limit switch.

# HDLS Series

Figure 4. MICRO SWITCH™ HDLS top rotary (single pole) dimensions

## SPDT Plug-in (mm[in])

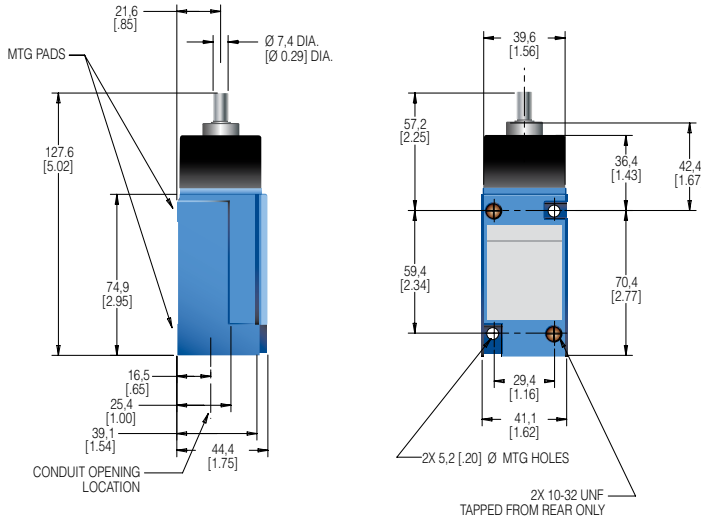
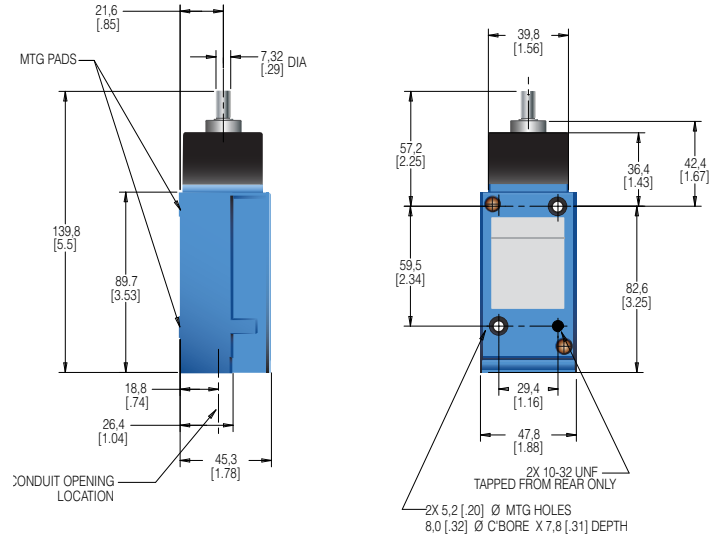
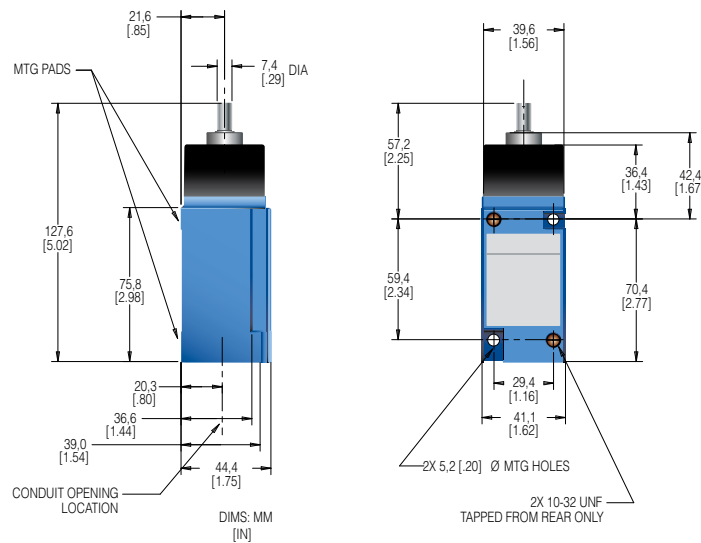


Figure 5. MICRO SWITCH™ HDLS top rotary (double pole) dimensions

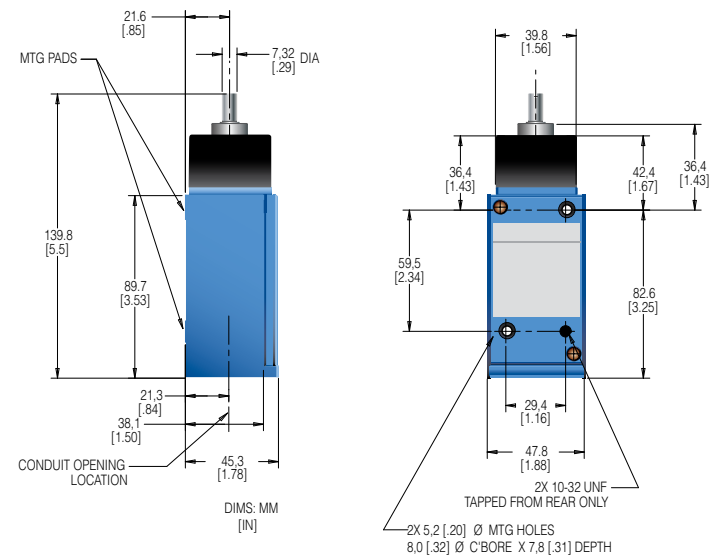
## DPDT Plug-in (mm[in])



## SPDT Non-plug-in (mm[in])



## DPDT Non-plug-in (mm[in])



# MICRO SWITCH™ Heavy-Duty Limit Switches

**Table 2. Common levers for use with MICRO SWITCH™ HDLS Rotary Switches**

Levers for use with side or top rotary actuated switches are available in a wide choice of sizes and materials. The most common listings are shown below. Rollers may be on either side of the lever to best match the external actuating mechanism.

							
<b>LSZ51A&amp;C</b> fixed rotary lever, nylon roller, front/ back	<b>LSZ51B&amp;D</b> fixed rotary lever, steel roller, front/ back	<b>LSZ59A,LSZ59B, LSZ59C,LSZ59D</b> short fixed lever, front/back			<b>LSZ69CA</b> spoke lever - 152 mm [6 in]		
							
<b>LSZ55A,LSZ55B, LSZ55C,LSZ55D</b> offset lever, front/back	<b>LSZ60</b> one-way roller lever	<b>LSZ53A, LSZ53B, LSZ53C, LSZ53D</b> yoke lever, nylon and steel rollers, front/back placement		<b>LSZ54R</b> spring wire 305 mm [12 in]			
							
<b>LSZ52A, LSZ52B, LSZ52C, LSZ52D</b> adj. lever, nylon/ steel, front/back	<b>LSZ52J</b> adjustable lever, nylon roller Ø 25,4 mm [Ø 1 in]	<b>LSZ52K</b> adjustable lever, nylon roller Ø 38,1 mm [Ø 1.5 in]	<b>LSZ54M</b> aluminum rod Ø 140 mm [Ø 5.5 in]	<b>LSZ61</b> loop 152 mm [6 in]	<b>LSZ67AA*</b> Plastic conveyor roller	<b>LSZ68</b> rod w/ spring 305 mm [12 in]	<b>LSZ54N</b> stainless steel rod 330 mm [13 in]

\* May require orientation of switch and lever to enable gravity to help restore free position of switch.

# HDLS Series

Table 3. HDLS SERIES ACTUATOR CODE TABLE (see previous page)

Catalog Listing	Material	Rod/Roller Dia. mm [in]	Rod/Roller Width mm [in]	Roller Mounting	
<b>Fixed 38,1 mm [1.5 in] radius</b>					
	–	Rollerless	n/a	n/a	
LSZ51A	Nylon	19 [0.75]	6,35 [0.25]	Front	
LSZ51B	Steel	19 [0.75]	6,35 [0.25]	Front	
LSZ51C	Nylon	19 [0.75]	6,35 [0.25]	Back	
LSZ51D	Steel	19 [0.75]	6,35 [0.25]	Back	
LSZ51F	Nylon	25,4 [1.0]	12,7 [0.50]	Front	
LSZ51G	Nylon	38,1 [1.5]	6,35 [0.25]	Front	
LSZ51J	Nylon	25,4 [1.0]	12,7 [0.50]	Back	
LSZ51L	Ball bearing	19 [0.75]	6,35 [0.25]	Back	
LSZ51M	Nylon	19 [0.75]	31,7 [1.25]	Back	
LSZ51N	Steel	19 [0.75]	31,7 [1.25]	Front	
LSZ51P	Nylon	19 [0.75]	12,7 [0.50]	Front	
<b>Adjustable 38,1 mm to 89,0 mm [1.5 in to 3.5 in] radius</b>					
	–	Rollerless	n/a	n/a	
LSZ52A	Nylon	19 [0.75]	6,35 [0.25]	Back	
LSZ52B	Steel	19 [0.75]	6,35 [0.25]	Back	
LSZ52C	Nylon	19 [0.75]	6,35 [0.25]	Front	
LSZ52D	Steel	19 [0.75]	6,35 [0.25]	Front	
LSZ52E	Nylon	19 [0.75]	33,0 [1.30]	Front	
LSZ52J	Nylon	25,4 [1.0]	12,7 [0.50]	Front	
LSZ52K	Nylon	38,1 [1.5]	6,35 [0.25]	Front	
LSZ52L	Ball bearing	19 [0.75]	6,35 [0.25]	Front	
LSZ52M	Nylon	50,8 [2.0]	6,35 [0.25]	Front	
LSZ52N	Nylon	19 [0.75]	12,7 [0.50]	Front	
<b>Yoke – 38,1 mm [1.5 in] radius</b>					
	LSZ53A	Nylon	19 [0.75]	6,35 [0.25]	Front/Back
	LSZ53B	Steel	19 [0.75]	6,35 [0.25]	Front/Back
	LSZ53D	Steel	19 [0.75]	6,35 [0.25]	Front/Front
	LSZ53E	Nylon	19 [0.75]	6,35 [0.25]	Back/Front
	LSZ53M	Nylon	19 [0.75]	31,7 [1.25]	Back/Front
	LSZ53P	Steel	19 [0.75]	6,35 [0.25]	Back/Back
	LSZ53S	Nylon	19 [0.75]	6,35 [0.25]	Back/Back
<b>Rod</b>					
	–	Hub only	n/a	n/a	
	LSZ54M	Alum, 140 mm [5.5 in]	Ø 3.2 [Ø 0.125]	n/a	n/a
	LSZ54N	Stainless, 330 mm [13 in]	Ø 3.2 [Ø 0.125]	n/a	n/a
	LSZ54R	SST spring wire, 305 mm [12 in]	Ø 1.9 [Ø 0.075]	n/a	n/a
	LSZ54V	Flex cable (tin plated steel), 122 mm [4.8 in]	Ø 4.8 [Ø 0.19]	n/a	n/a
	LSZ54P	Plastic rod, 305 mm [12 in]	Ø 6,85 [Ø 0.27]	n/a	n/a
	LSZ54W	Plastic rod, 183 mm [7.2 in]	Ø 6,85 [Ø 0.27]	n/a	n/a
	LSZ59T	330 [13] stainless steel	Ø 4,8 [Ø 0.19]	n/a	n/a
<b>Spoke</b>					
	LSZ69CA	152 mm [6.0 in] Stainless	3,2 [0.125]	n/a	n/a

Catalog Listing	Material	Rod/Roller Dia. mm [in]	Rod/Roller Width mm [in]	Roller Mounting	
<b>Fixed 38,1 mm [1.5 in] radius</b>					
	–	Rollerless	n/a	n/a	
LSZ55A	Nylon	19 [0.75]	6,35 [0.25]	Back	
LSZ55B	Steel	19 [0.75]	6,35 [0.25]	Back	
LSZ55C	Nylon	19 [0.75]	6,35 [0.25]	Front	
LSZ55D	Steel	19 [0.75]	6,35 [0.25]	Front	
LSZ55E	Nylon	19 [0.75]	12,7 [0.50]	Front	
LSZ55K	Nylon	38,1 [1.5]	6,35 [0.25]	Front	
<b>Short fixed - 33 mm [1.3 in] radius</b>					
	LSZ59A	Nylon	19 [0.75]	6,35 [0.25]	Front
	LSZ59B	Steel	19 [0.75]	6,35 [0.25]	Front
	LSZ59C	Nylon	19 [0.75]	6,35 [0.25]	Back
	LSZ59D	Steel	19 [0.75]	6,35 [0.25]	Back
<b>38,1 mm [1.5 in] radius one-way roller lever</b>					
	LSZ60A	Nylon	19 [0.75]	6,35 [0.25]	Front
	LSZ60B	Steel	19 [0.75]	6,35 [0.25]	Front
<b>Flexible loop</b>					
	LSZ61	Ø 4,8 [Ø 0.19] Nylatron	152 mm [6 in] flexible loop		
	LSZ618	Ø 4,8 [Ø 0.19] Nylatron	241 mm [9.5 in] flexible loop		
	LSZ54	Hub only	n/a	n/a	
<b>Spring rod</b>					
	LSZ68	Delrin rod, 305 [12 ]	Ø 6,35 [Ø 0.25]	n/a	n/a
	LSZ617	Delrin rod, 406 [16]	Ø 6,35 [Ø 0.25]	n/a	n/a
	LSZ686	Delrin rod, 152 [6]	Ø 6,35 [Ø 0.25]	n/a	n/a
<b>Rubber roller levers</b>					
	LSZ51Y	Rubber	50 [2.0]	12,7 [0.50]	front
	LSZ55Y	Rubber	50 [2.0]	12,7 [0.50]	front
	LSZ52Y	Rubber	50 [2.0]	12,7 [0.50]	front
<b>Plastic roller levers</b>					
	LSZ67AA* (conveyor)	Plastic	38,1 [1.5]	96,5 [3.8]	n/a

\* may require orientation of switch and lever to enable gravity to help restore free position of switch.



# MICRO SWITCH™ Heavy-Duty Limit Switches

## MICRO SWITCH™ HDLS SIDE ROTARY LEVERS' CAM TRACKING

Levers for side and top rotary switches are normally ordered as separate catalog listings. They also may be ordered by including a suffix to the switch catalog listing (see nomenclature tree in this document) and adding the lever price.

Figure 6. LSZ51 type levers cam tracking

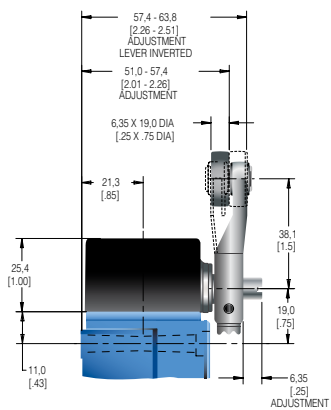


Figure 7. LSZ52 type levers cam tracking

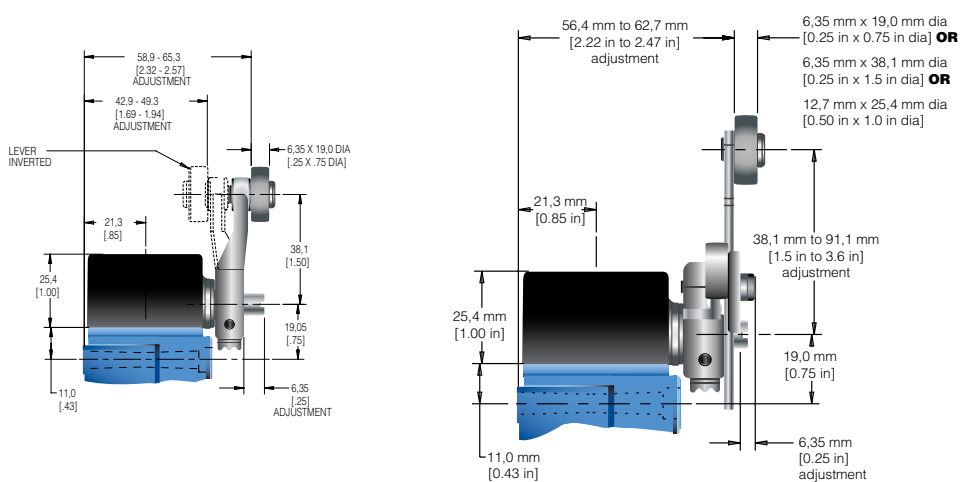


Figure 8. LSZ54 type levers cam tracking

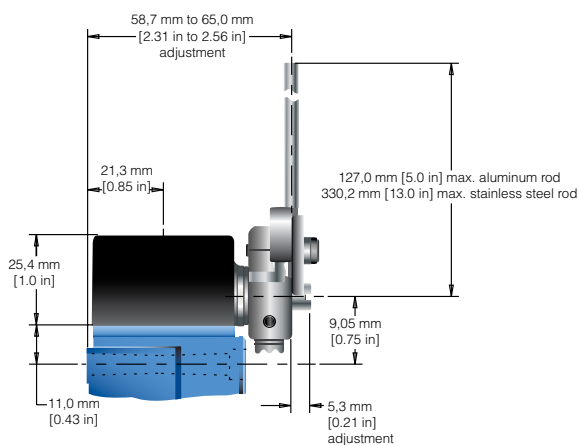


Figure 9. LSZ55 type levers cam tracking



# HDLS Series

## TOP PLUNGERS • MICRO SWITCH™ HDLS SERIES ORDER GUIDE/RECOMMENDED LISTINGS

All top plungers are momentary action.



Description	Plain (LSC)		Roller (LSD)		Adjustable (LSV)	
	SPDT	DPDT	SPDT	DPDT	SPDT	DPDT
Top plain plunger for in-line operating motion						
	<p>Contact closed ■ Contact open □</p>					
<b>Pretravel</b>	1,78 mm [0.07 in]					
<b>Different. travel</b>	0,38 mm [0.015 in]	0,51 mm [0.02 in]	0,38 mm [0.015 in]	0,51 mm [0.02 in]	0,38 mm [0.015 in]	0,51 mm [0.02 in]
<b>Overtravel</b>	4,83 mm [0.19 in]					
<b>Operating point (nom.)</b>	45,8 mm [1.805 in]		55,9 mm [2.20 in]		53 mm to 59 mm [2.08 in to 2.34 in]	
<b>Operating force</b>	17,8 N [4 lb] max.					
<b>Op. temp range<sup>3</sup></b>	-12 °C to 93 °C [10 °F to 200 °F] (for low temp, high temp, or preloaded versions, see page 11-12)					

Circuitry	Contacts	Body Style <sup>2</sup>	Conduit (NPT)	Options	LSC	LSD	LSV
	Silver	Plug-in	0.5 in		<b>LSC1A</b>	<b>LSD1A</b>	<b>LSV1A</b>
	Gold <sup>4</sup>	Plug-in	0.5 in		<b>LSC1E</b>	<b>LSD1E</b>	<b>LSV1E</b>
	Silver	Plug-in	0.5 in	120 V Ind. lite <sup>1</sup>	<b>LSC5A</b>	<b>LSD5A</b>	<b>LSV5A</b>
	Silver	Plug-in	0.5 in	240 V Ind. lite <sup>1</sup>	<b>LSC8A</b>	<b>LSD8A</b>	<b>LSV8A</b>
	Silver	Non-plug-in	0.5 in		<b>LSC3K</b>	<b>LSD3K</b>	<b>LSV3K</b>
	Silver	Plug-in	0.75 in		<b>LSC2B</b>	<b>LSD2B</b>	<b>LSV2B</b>
	Silver	Plug-in	0.5 in		<b>LSC2R</b>	<b>LSD2R</b>	<b>LSV2R</b>
	Silver	Plug-in	0.75 in	120 V Ind. lite <sup>1</sup>	<b>LSC6B</b>	<b>LSD6B</b>	<b>LSV6B</b>
	Silver	Non-plug-in	0.75 in		<b>LSC4L</b>	<b>LSD4L</b>	<b>LSV4L</b>
	Silver	Non-plug-in	0.5 in		<b>LSC7L</b>	<b>LSD7L</b>	<b>LSV7L</b>

<sup>1</sup> Use at voltage indicated for light. Wired to NO circuit. Upper temperature limit for lighted units is 93 °C [200 °F]

<sup>2</sup> Plug-in listings include base receptacle

<sup>3</sup> Completely fluorocarbon sealed switches are preferred for use in temperatures above 93 °C [200 °F]

<sup>4</sup> Gold-plated contacts

NOTE: Same polarity each pole.

To order a fluorocarbon sealed switch, insert the letters **Y** and **C** into the catalog listing as follows. The LSA1A limit switch is changed to a LSY**AC**1A limit switch.

To order a low temperature, fluorosilicone sealed switch, insert the letters **Y** and **B** into the catalog listing as follows. The LSA1A limit switch is changed to a LSY**AB**1A limit switch.

# MICRO SWITCH™ Heavy-Duty Limit Switches

Figure 10. MICRO SWITCH™ HDLS LSC Series (single pole plunger dimensions)

## SPDT Plug-in (mm[in])

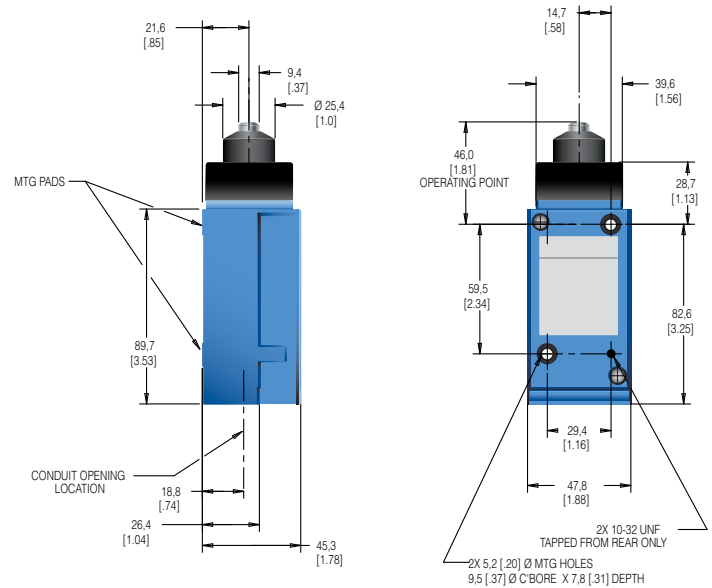


## SPDT Non-plug-in (mm[in])

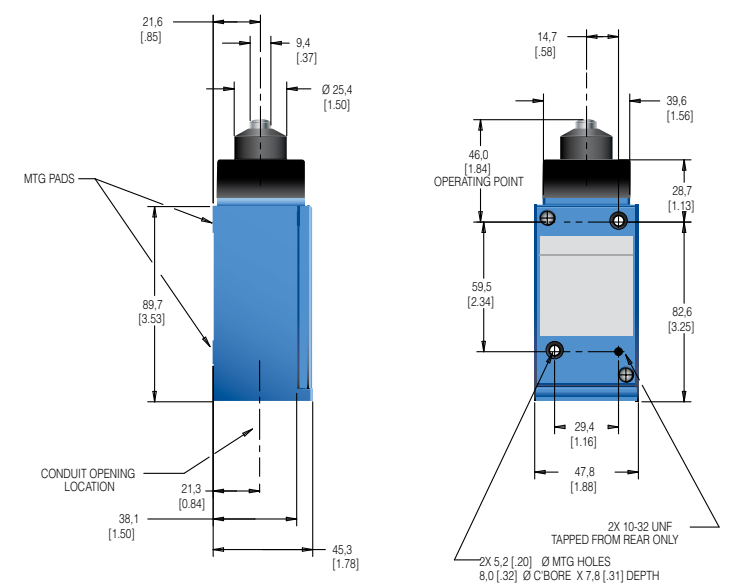


Figure 11. MICRO SWITCH™ HDLS LSC Series (double pole plunger dimensions)

## DPDT Plug-in (mm[in])



## DPDT Non-plug-in (mm[in])



# HDLS Series

Figure 12. MICRO SWITCH™ HDLS LSD Series (single pole) top roller plunger dimensions

## SPDT Plug-in (mm[in])



## SPDT Non-plug-in (mm[in])

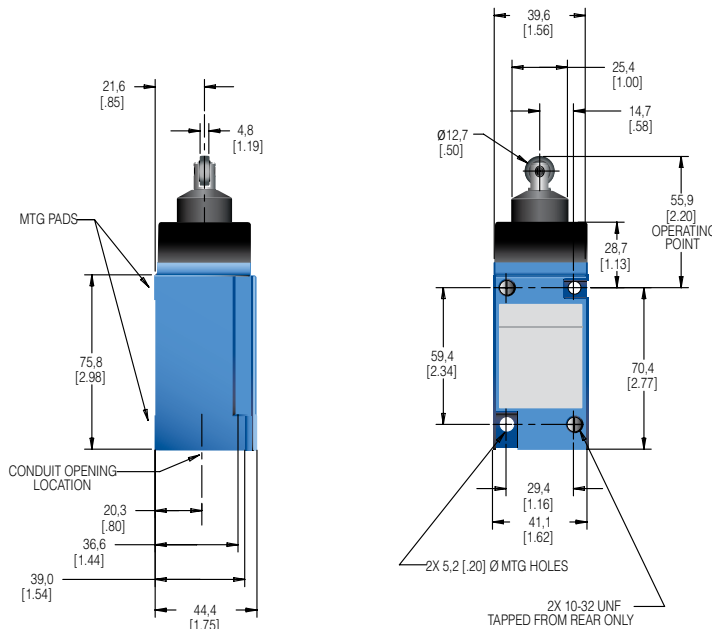
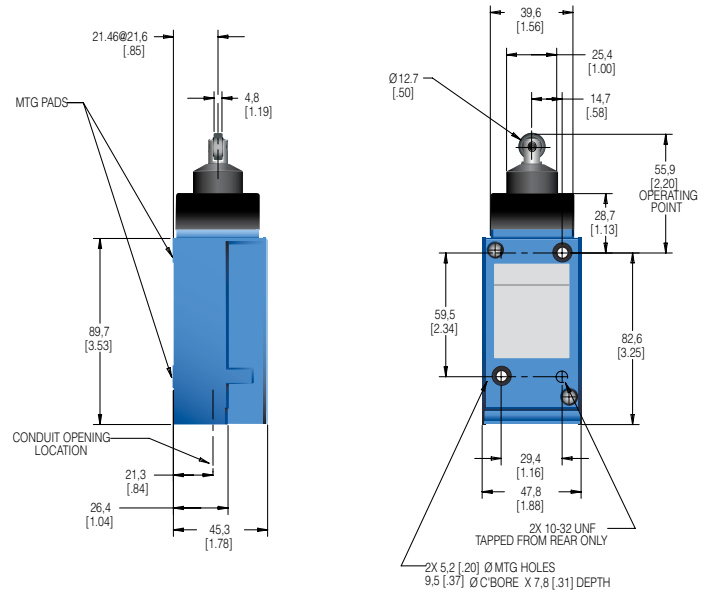
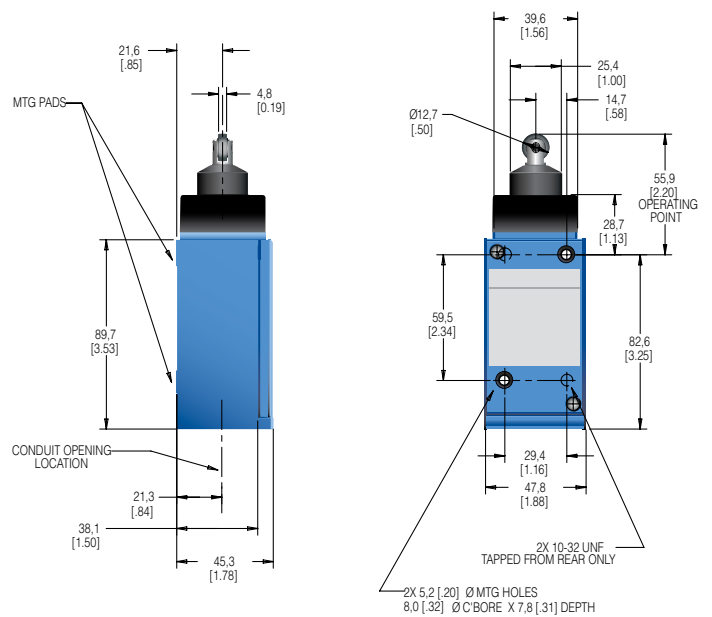


Figure 13. MICRO SWITCH™ HDLS LSD Series (double pole) top roller plunger dimensions

## DPDT Plug-in (mm[in])



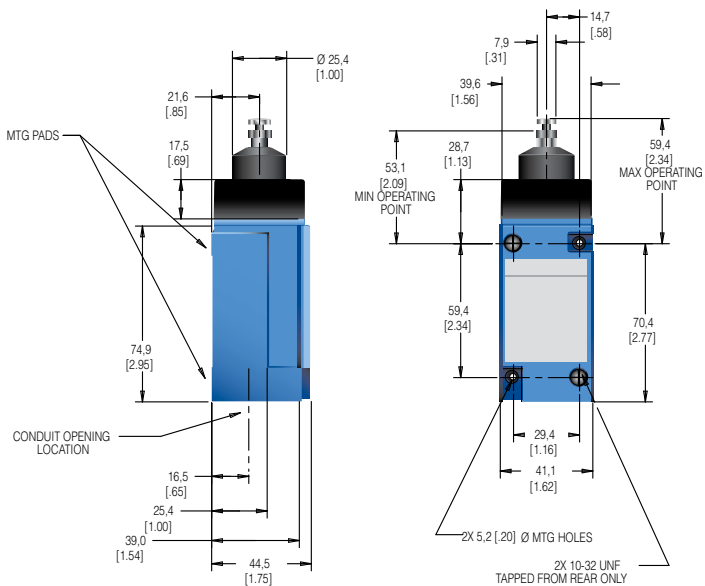
## DPDT Non-plug-in (mm[in])



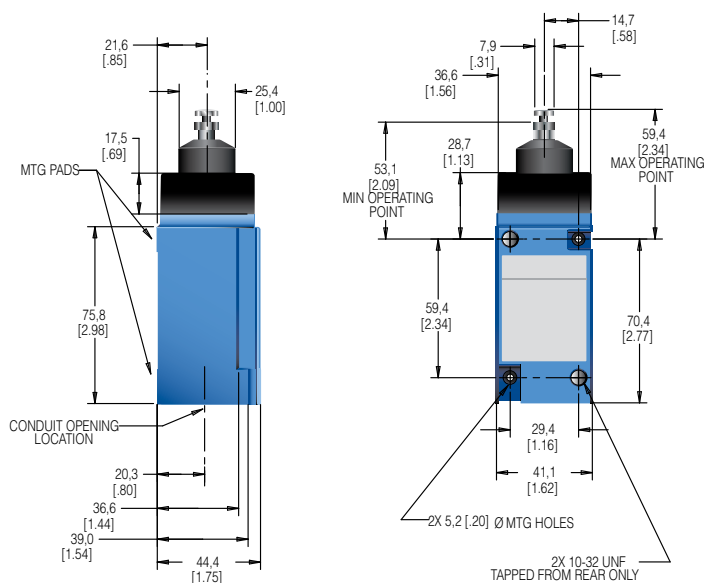
# MICRO SWITCH™ Heavy-Duty Limit Switches

Figure 14. MICRO SWITCH™ HDLS LSV Series top adjustable plunger (single pole) dimensions

## SPDT Plug-in (mm[in])



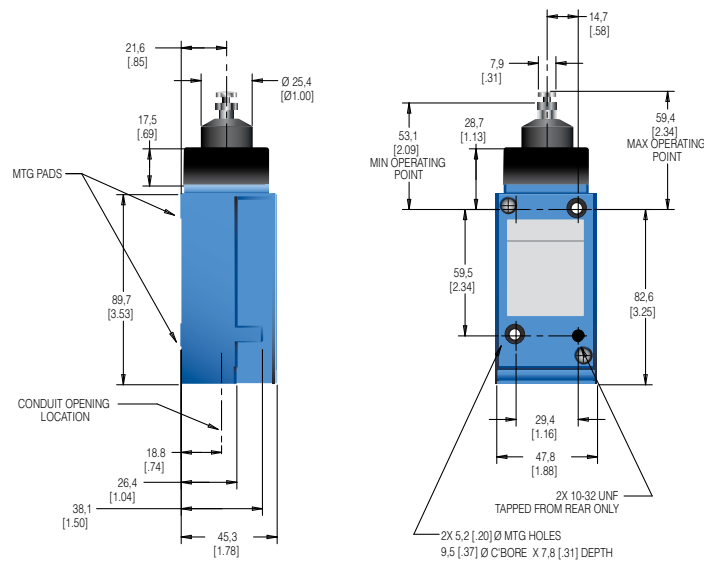
## SPDT Non-plug-in (mm[in])



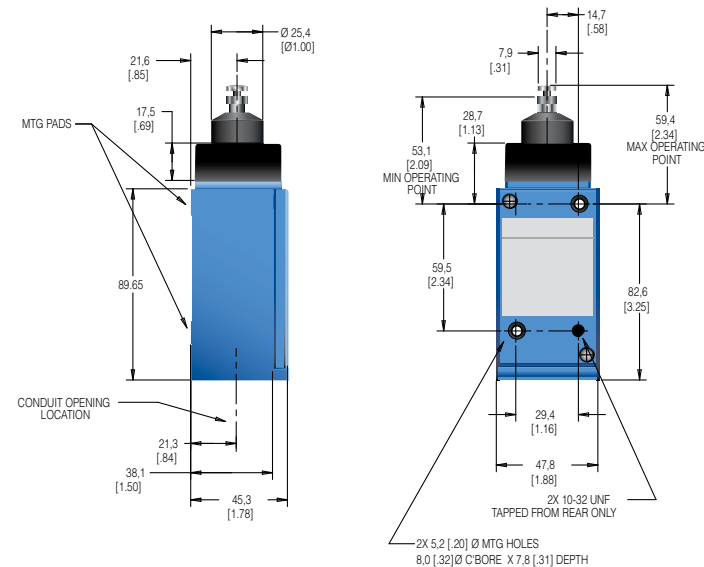
DIMS: MM  
[IN]

Figure 15. MICRO SWITCH™ HDLS LSV Series top adjustable plunger (double pole) dimensions

## DPDT Plug-in (mm[in])



## DPDT Non-plug-in (mm[in])





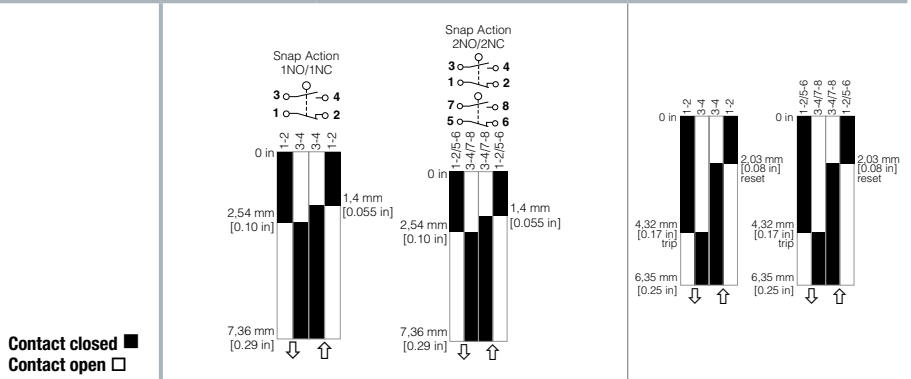
# HDLS Series

## SIDE PLUNGERS • MICRO SWITCH™ HDLS SERIES ORDER GUIDE/RECOMMENDED LISTINGS

Heads may be positioned to accept actuation from any of four directions, 90° apart.



	Plain (LSE)	Roller (LSF)	Adjustable (LSW)	Maintained (LSG)
<b>Description</b>	Side plain plunger (momentary)	Side roller plunger (momentary)	Adjustable side plain plunger (momentary)	Side plain plunger with maintained contact



Contact closed ■  
 Contact open □

<b>Pretravel</b>	2,54 mm [0.10 in]			4,32 mm [0.17 in]
<b>Different. travel</b>	Single pole: 0,64 mm [0.025 in] Double pole: 0,89 mm [0.035 in]			2,29 mm [0.09 in]
<b>Overtravel</b>	4,83 mm [0.19 in]			2,0 mm [0.08 in]
<b>Operating point (nominal)</b>	33,0 mm [1.30 in]	44,1 mm [1.74 in]	41,0 mm to 47,4 mm [1.62 in to 1.87 in]	67,6 mm [1.48 in]
<b>Operating force</b>	26,7 N [6 lb] max.			44,5 N [10 lb] max.
<b>Op. temp range<sup>3</sup></b>	-12 °C to 93 °C [10 °F to 200 °F] (for low temp, high temp, or preleaded versions, see pages 11-12)			-1 °C to 93 °C [30 °F to 200 °F] (for low temp, high temp, or preleaded versions, see page 11-12)

Circuitry		Contacts	Body Style <sup>2</sup>	Conduit (NPT)	Options				
SPDT Double Break		Silver	Plug-in	0.5 in		<b>LSE1A</b>	<b>LSF1A</b>	<b>LSW1A</b>	<b>LSG1A</b>
		Gold <sup>4</sup>	Plug-in	0.5 in		<b>LSE1E</b>	<b>LSF1E</b>	<b>LSW1E</b>	<b>LSG1E</b>
		Silver	Plug-in	0.5 in	120 V Ind. lite <sup>1</sup>	<b>LSE5A</b>	<b>LSF5A</b>	<b>LSW5A</b>	<b>LSG5A</b>
		Silver	Plug-in	0.5 in	240 V Ind. lite <sup>1</sup>	<b>LSE8A</b>	<b>LSF8A</b>	<b>LSW8A</b>	<b>LSG8A</b>
		Silver	Non-plug-in	0.5 in		<b>LSE3K</b>	<b>LSF3K</b>	<b>LSW3K</b>	<b>LSG3K</b>
DPDT Double Break		Silver	Plug-in	0.75 in		<b>LSE2B</b>	<b>LSF2B</b>	<b>LSW2B</b>	<b>LSG2B</b>
		Silver	Plug-in	0.5 in		<b>LSE2R</b>	<b>LSF2R</b>	<b>LSW2R</b>	<b>LSG2R</b>
		Silver	Plug-in	0.75 in	120 V Ind. lite <sup>1</sup>	<b>LSE6B</b>	<b>LSF6B</b>	<b>LSW6B</b>	<b>LSG6B</b>
		Gold <sup>4</sup>	Plug-in	0.5 in		<b>LSE6S</b>	-	-	-
		Silver	Non-plug-in	0.75 in		<b>LSE4L</b>	<b>LSF4L</b>	<b>LSW4L</b>	<b>LSG4L</b>
		Silver	Non-plug-in	0.5 in		<b>LSE7L</b>	<b>LSF7L</b>	<b>LSW7L</b>	<b>LSG7L</b>

<sup>1</sup> Use at voltage indicated for light. Wired to NO circuit. Upper temperature limit for lighted units is 93 °C [200 °F]

<sup>2</sup> Plug-in listings include base receptacle

<sup>3</sup> Completely fluorocarbon sealed switches are preferred for use in temperatures above 93 °C [200 °F]

<sup>4</sup> Gold-plated contacts

NOTE: Same polarity each pole.

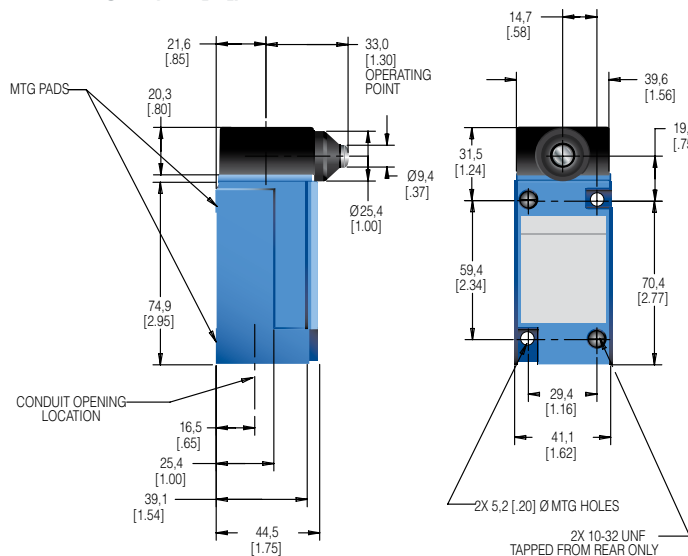
To order a fluorocarbon sealed switch, insert the letters **Y** and **C** into the catalog listing as follows. The LSA1A limit switch is changed to a LSY**AC**1A limit switch.

To order a low temperature, fluorosilicone sealed switch, insert the letters **Y** and **B** into the catalog listing as follows. The LSA1A limit switch is changed to a LSY**AB**1A limit switch.

# MICRO SWITCH™ Heavy-Duty Limit Switches

Figure 16. MICRO SWITCH™ HDLS LSE Series side plain plunger (single pole) dimensions

## SPDT Plug-in (mm[in])



## SPDT Non-plug-in (mm[in])

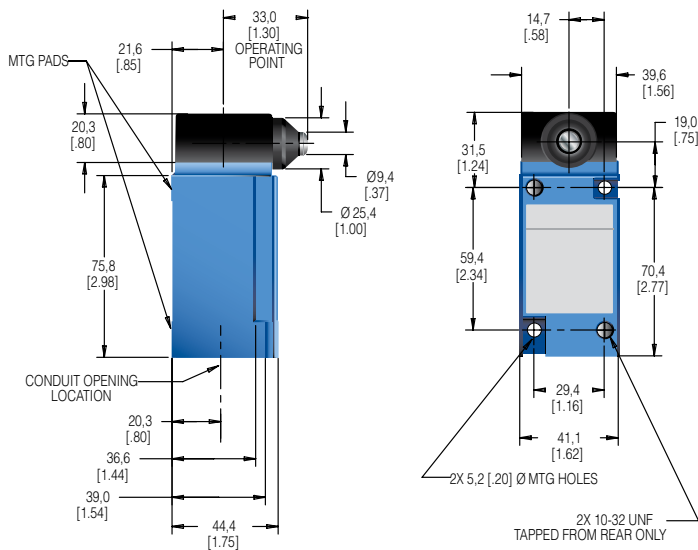
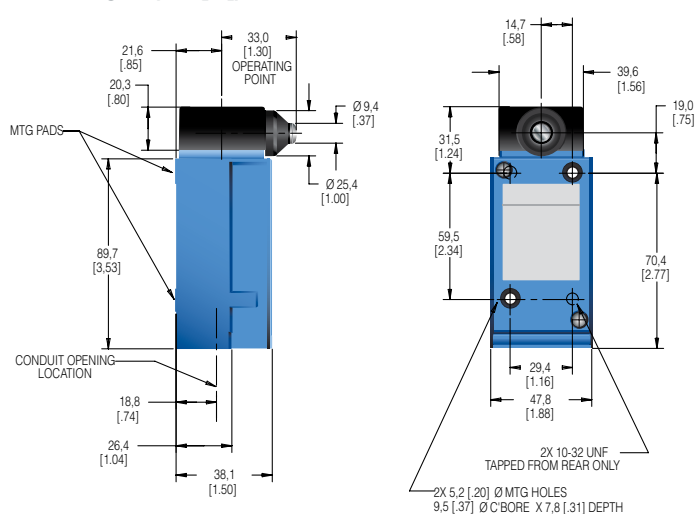
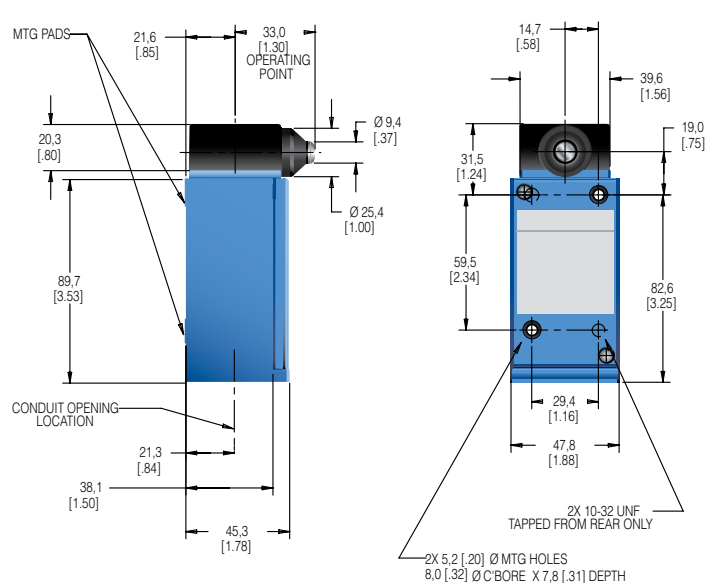


Figure 17. MICRO SWITCH™ HDLS LSE Series side plain plunger (double pole) dimensions

## DPDT Plug-in (mm[in])



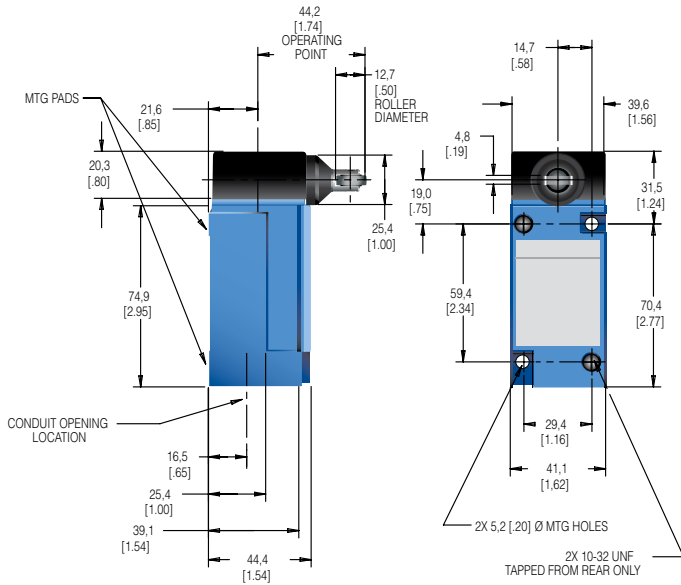
## DPDT Non-plug-in (mm[in])



# HDLS Series

Figure 18. MICRO SWITCH™ HDLS LSF Series side roller plunger (single pole) dimensions

## SPDT Plug-in (mm[in])



## SPDT Non-plug-in (mm[in])

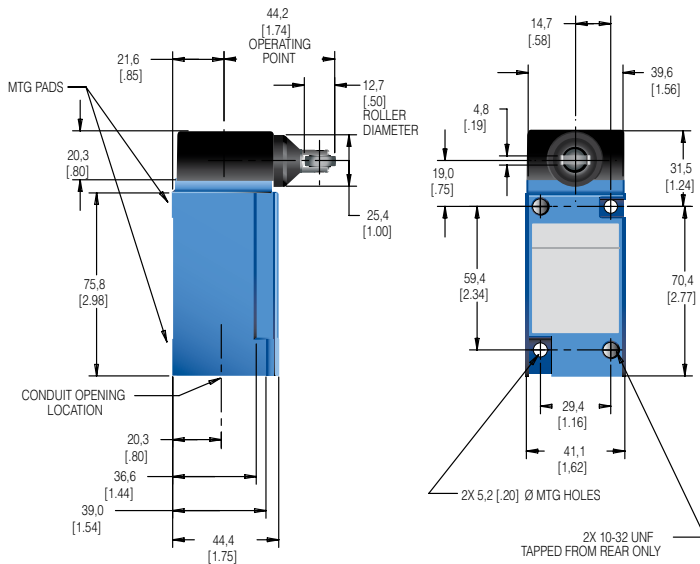
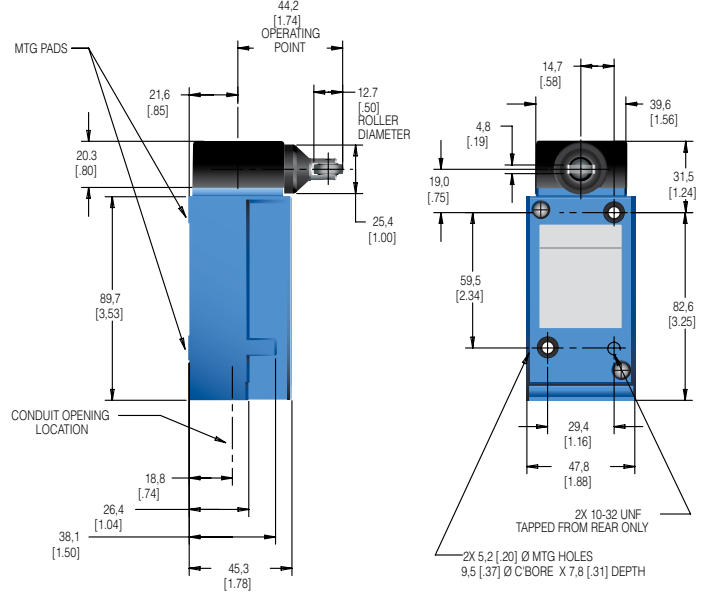
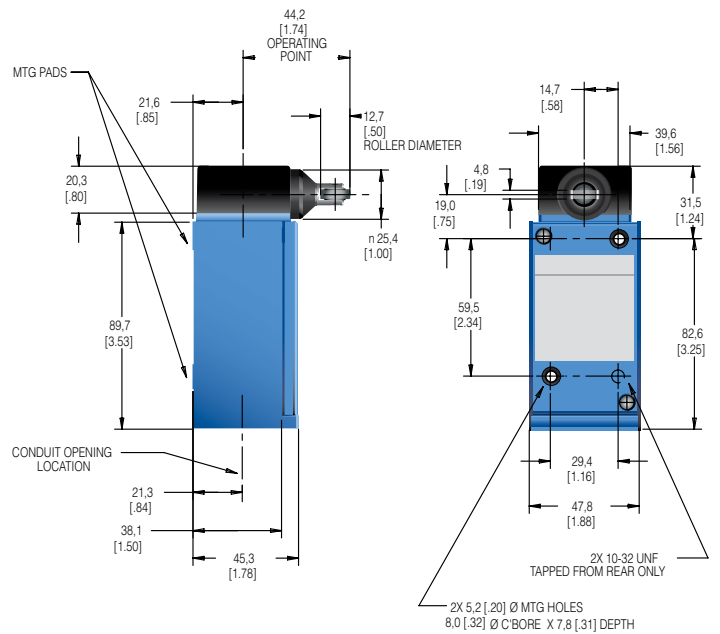


Figure 19. MICRO SWITCH™ HDLS LSF Series side roller plunger (double pole) dimensions

## DPDT Plug-in (mm[in])



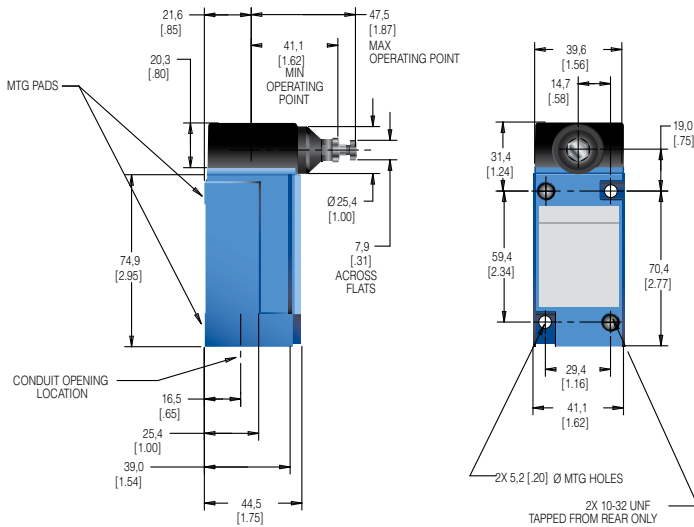
## DPDT Non-plug-in (mm[in])



# MICRO SWITCH™ Heavy-Duty Limit Switches

Figure 20. MICRO SWITCH™ HDLS LSW Series side adjustable plunger (single pole) dimensions

## SPDT Plug-in (mm[in])



## SPDT Non-plug-in (mm[in])

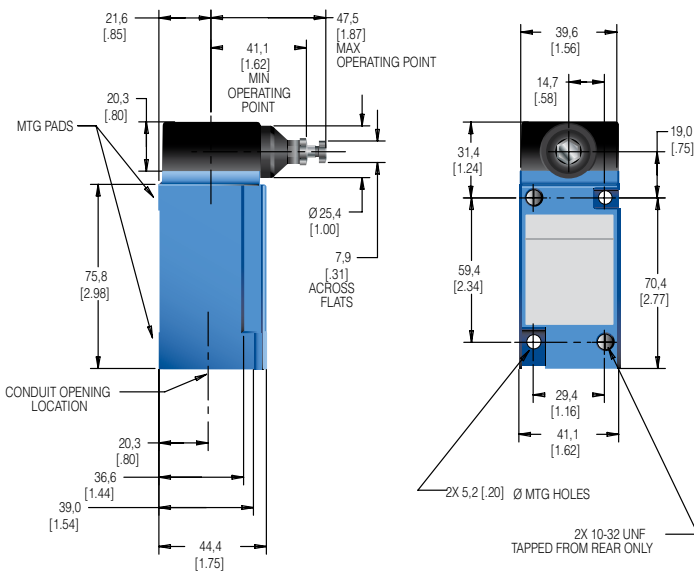
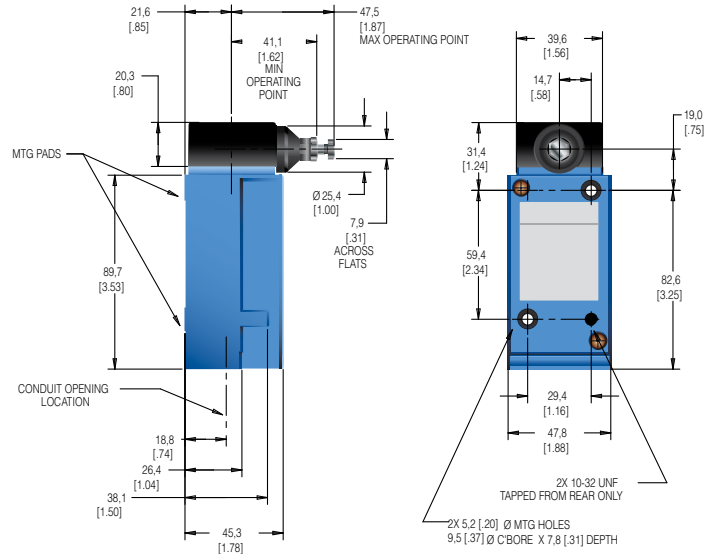
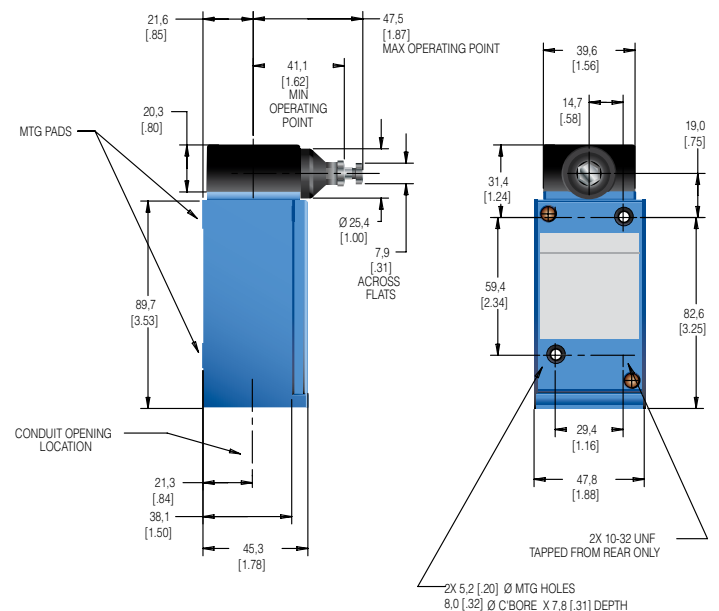


Figure 21. MICRO SWITCH™ HDLS LSW Series side adjustable plunger (double pole) dimensions

## DPDT Plug-in (mm[in])



## DPDT Non-plug-in (mm[in])



# HDLS Series

Figure 22. MICRO SWITCH™ HDLS LSG Series maintained contact side plunger (single pole) dimensions

## SPDT Plug-in (mm[in])

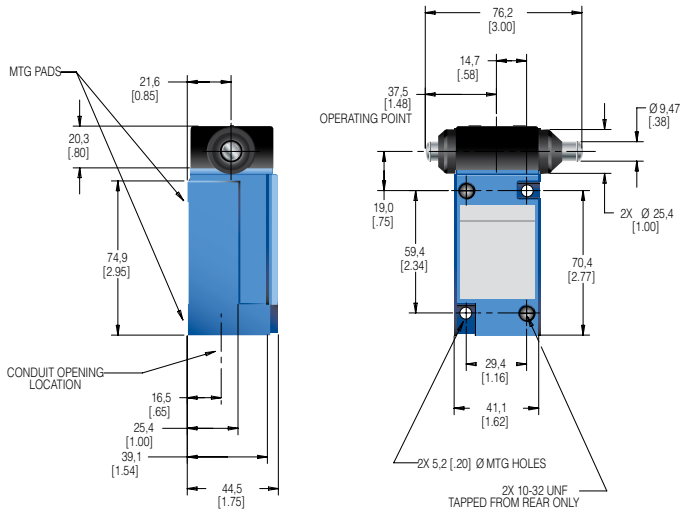
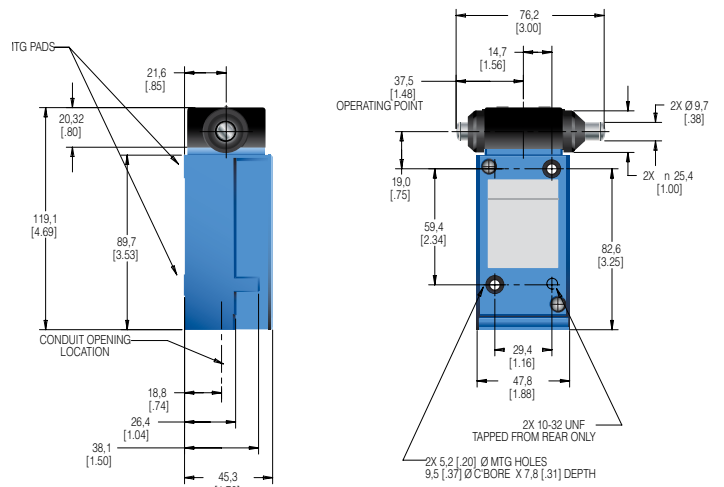
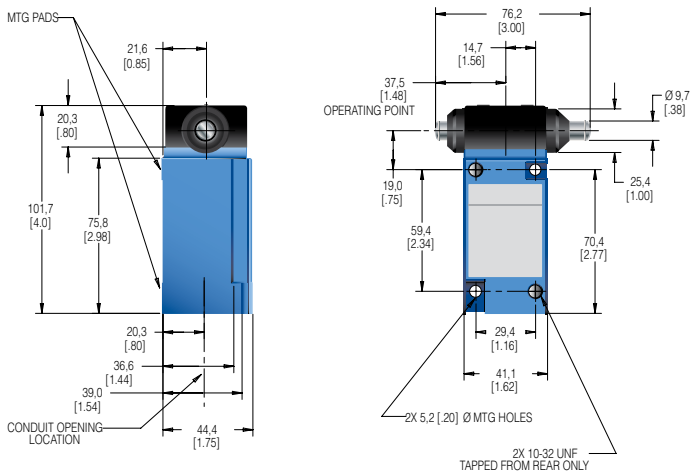


Figure 23. MICRO SWITCH™ HDLS LSG Series maintained contact side plunger (double pole) dimensions

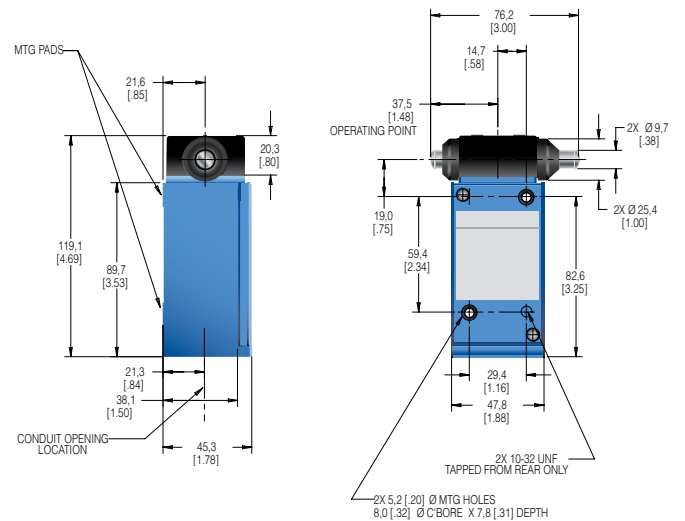
## DPDT Plug-in (mm[in])



## SPDT Non-plug-in (mm[in])


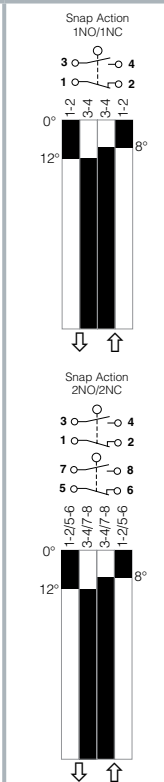
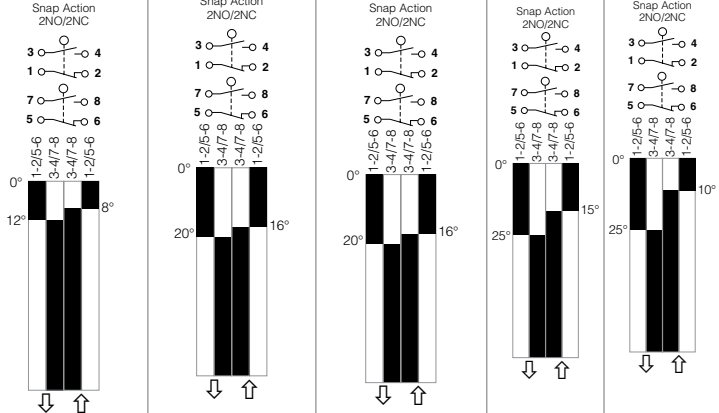
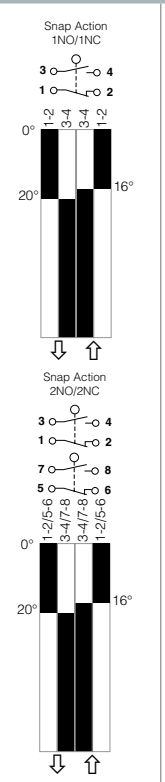
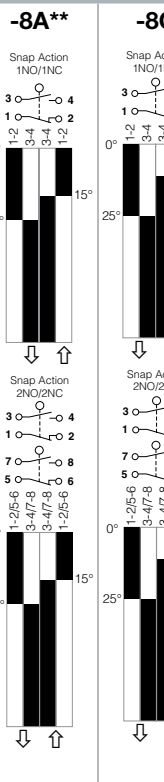



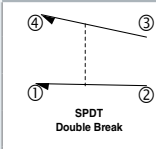
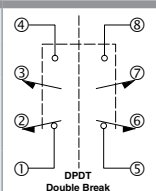
## DPDT Non-plug-in (mm[in])



# MICRO SWITCH™ Heavy-Duty Limit Switches

## WOBBLES • MICRO SWITCH™ HDLS SERIES ORDER GUIDE/RECOMMENDED LISTINGS

	LSJ Series 7A Actuator	LSJ Series 7N Actuator	LSJ Series 7M Actuator	LSK Series 8A-8C Actuator		
<b>Description</b>	Plastic rod lever (wobble stick)	Flexible cable lever	Spring wire lever - may be formed for special needs	Cat whisker actuator for low operating force applications		
 <p> <b>LSJ1A-7A</b> - Plastic rod  <b>LSJ1A-7M</b> - Spring wire  <b>LSJ1A-7N</b> - Flexible actuator  <b>LSK1A-8A</b> - Cat whisker  <b>LSK1A-8C</b> - Coil spring                 </p>						
	<b>Legend</b>	Contact closed ■ Contact open □				
	<b>Lever length from top mounting hole</b>	Actuator: 140 mm [5.5 in]	Actuator: 140 mm [5.5 in]	Actuator: 330 mm [13 in]	8A act.: 140 mm [5.5 in] SST 8C act.: 140 mm [5.5 in] steel plated	
	<b>Pretravel</b>	25,4 mm [1.0 in]	38,0 mm [1.5 in]	102 mm [4.0 in]	51,0 mm [2.0 in]	
	<b>Oper. force</b>	2,78 Nm [10 oz]	1,95 Nm [7 oz]	1,39 Nm [5 oz]	8A: 1,39 Nm [5 oz]; 8C: 1,95 Nm [7 oz]	
<b>Op. temp range<sup>3</sup></b>	-12 °C to 93 °C [10°F to 200 °F] (for low temp, high temp, or preloaded versions, see pages 11-12)					

Circuitry	Contacts	Body Style <sup>2</sup>	Conduit (NPT)	Options	LSJ1A-7A	LSJ1A-7N	LSJ1A-7M	LSK1A-8A	LSK1A-8C
 <p>SPDT Double Break</p>	Silver	Plug-in	0.5 in		LSJ1A-7A	LSJ1A-7N	LSJ1A-7M	LSK1A-8A	LSK1A-8C
	Gold <sup>4</sup>	Plug-in	0.5 in		LSJ1E-7A	-	LSJ1E-7M	LSK1E-8A	LSK1E-8C
	Silver	Plug-in	0.5 in	120 V Ind. lite <sup>1</sup>	LSJ5A-7A	LSJ5A-7N	LSJ5A-7M	LSK5A-8A	LSK5A-8C
	Silver	Plug-in	0.5 in	240 V Ind. lite <sup>1</sup>	LSJ8A-7A	LSJ8A-7N	LSJ8A-7M	LSK8A-8A	LSK8A-8C
	Silver	Non-plug-in	0.5 in		LSJ3K-7A	LSJ3K-7N	LSJ3K-7M	LSK3K-8A	LSK3K-8C
 <p>DPDT Double Break</p>	Silver	Plug-in	0.75 in		LSJ2B-7A	LSJ2B-7N	LSJ2B-7M	LSK2B-8A	LSK2B-8C
	Silver	Plug-in	0.5 in		LSJ6B-7A	LSJ6B-7N	LSJ6B-7M	LSK6B-8A	LSK6B-8C
	Silver	Plug-in	0.75 in	120 V Ind. lite <sup>1</sup>	LSJ2R-7A	LSJ2R-7N	LSJ2R-7M	LSK2R-8A	LSK2R-8C
	Silver	Non-plug-in	0.75 in		LSJ4L-7A	LSJ4L-7N	LSJ4L-7M	LSK4L-8A	LSK4L-8C
	Silver	Non-plug-in	0.5 in		LSJ7L-7A	LSJ7L-7N	LSJ7L-7M	LSK7L-8A	LSK7L-8C

<sup>1</sup> Use at voltage indicated for light. Wired to NO circuit. Upper temperature limit for lighted units is 93°C [200 °F]

<sup>2</sup> Plug-in listings include base receptacle

<sup>3</sup> Completely fluorocarbon sealed switches are preferred for use in temperatures above 93 °C [200 °F]

<sup>4</sup> Gold-plated contacts

\*\* These cat whiskers have a 140 mm [5.5 in] long actuator. To specify a 190 mm [7.5 in] length actuator, substitute **-8B** for **-8A**.

NOTE: Same polarity each pole.

To order a fluorocarbon sealed switch, insert the letters **Y** and **C** into the catalog listing as follows. The LSA1A limit switch is changed to a LSYAC1A limit switch.

To order a low temperature, fluorosilicone sealed switch, insert the letters **Y** and **B** into the catalog listing as follows. The LSA1A limit switch is changed to a LSYAB1A limit switch.



# HDLS Series

Figure 24. MICRO SWITCH™ HDLS LSJ\_\_-7A Series wobble (single pole) dimensions

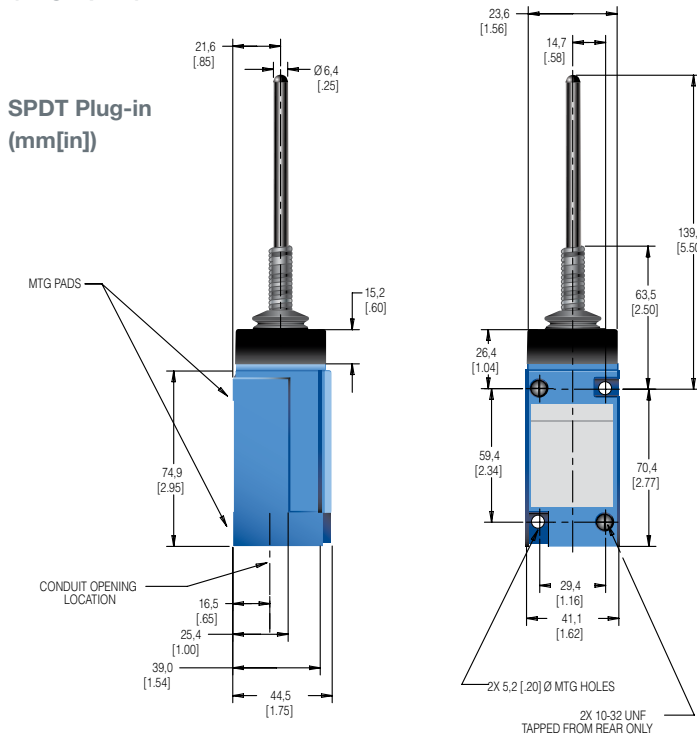
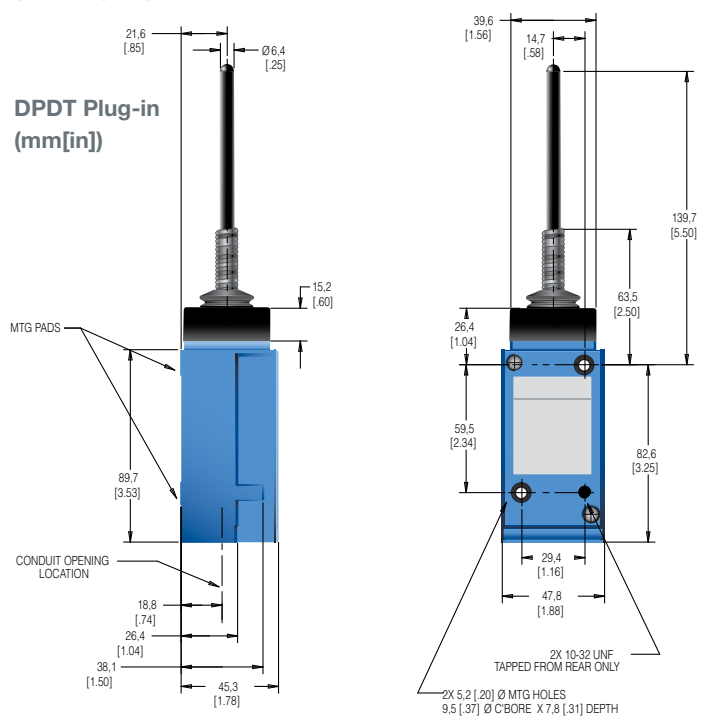


Figure 25. MICRO SWITCH™ HDLS LSJ\_\_-7A Series wobble (double pole) dimensions



# MICRO SWITCH™ Heavy-Duty Limit Switches

Figure 26. MICRO SWITCH™ HDLS LSJ\_\_-7N Series wobble (single pole) dimensions

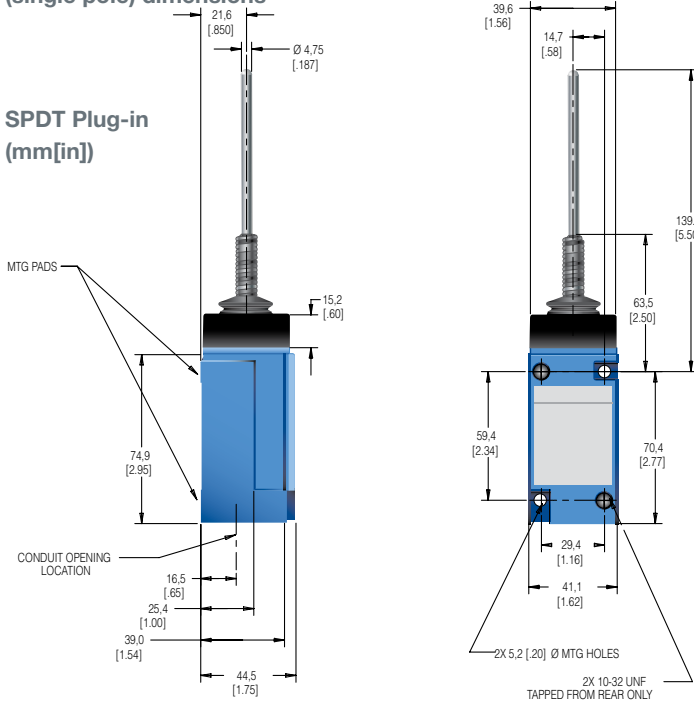
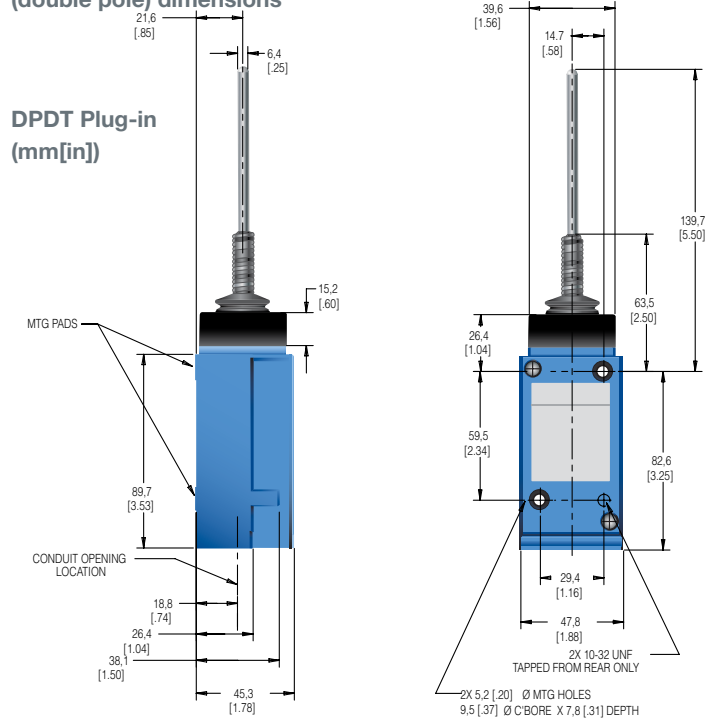
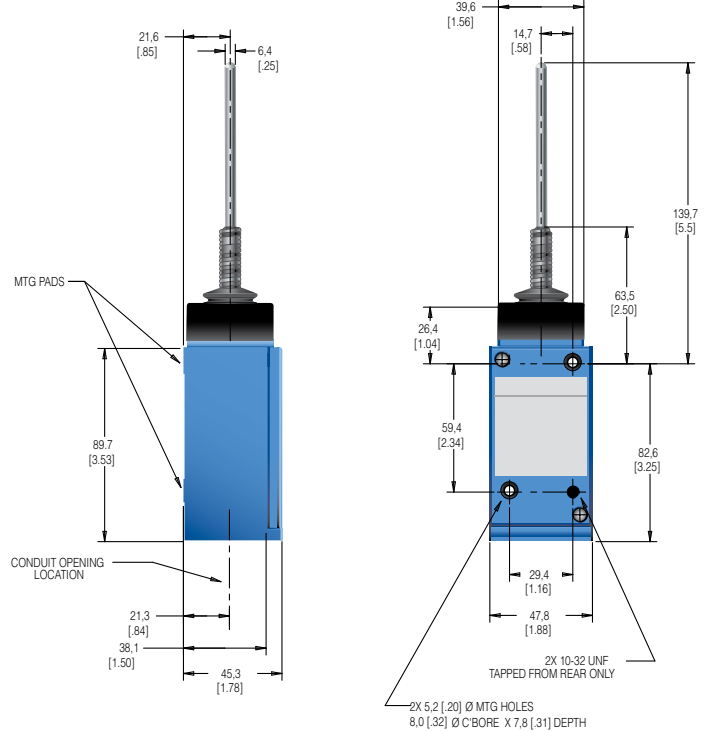
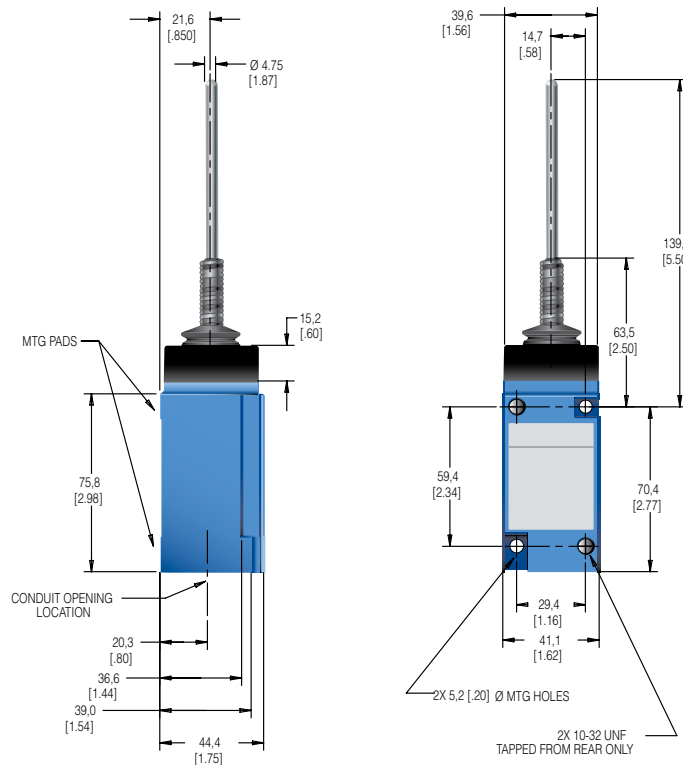


Figure 27. MICRO SWITCH™ HDLS LSJ\_\_-7N Series wobble (double pole) dimensions



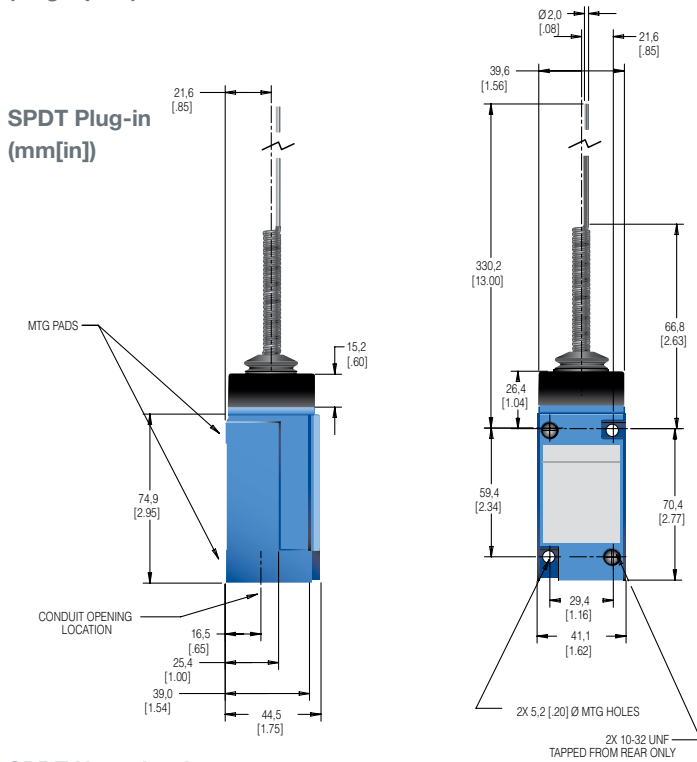
SPDT Non-plug-in (mm[in])

DPDT Non-plug-in (mm[in])

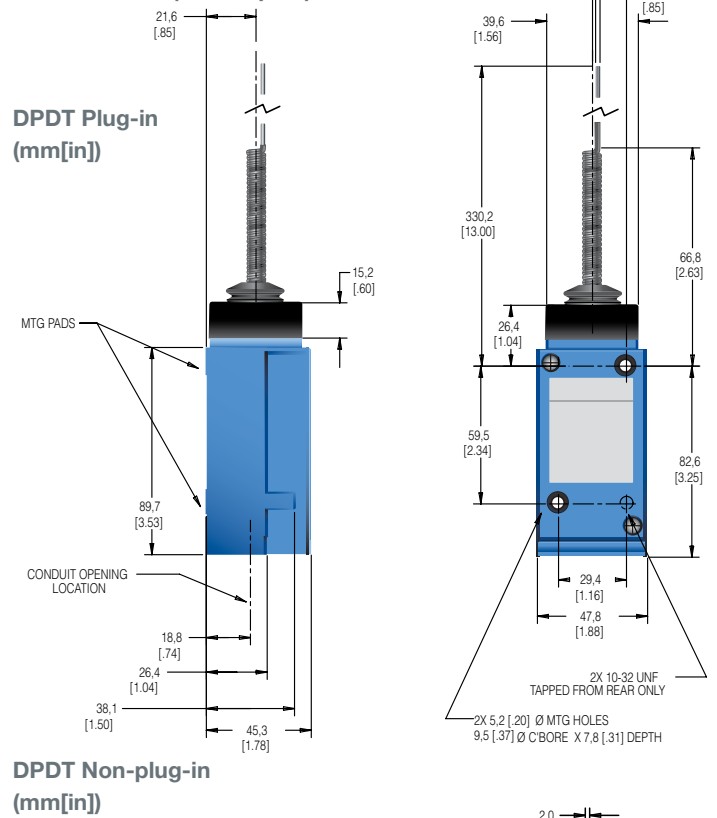


# HDLS Series

**Figure 28. MICRO SWITCH™ HDLS LSJ\_\_-7M Series wobble (single pole) dimensions**



**Figure 29. MICRO SWITCH™ HDLS LSJ\_\_-7M Series wobble (double pole) dimensions**



# MICRO SWITCH™ Heavy-Duty Limit Switches

Figure 30. MICRO SWITCH™ HDLS LSK\_\_-8A Series wobble (single pole) dimensions

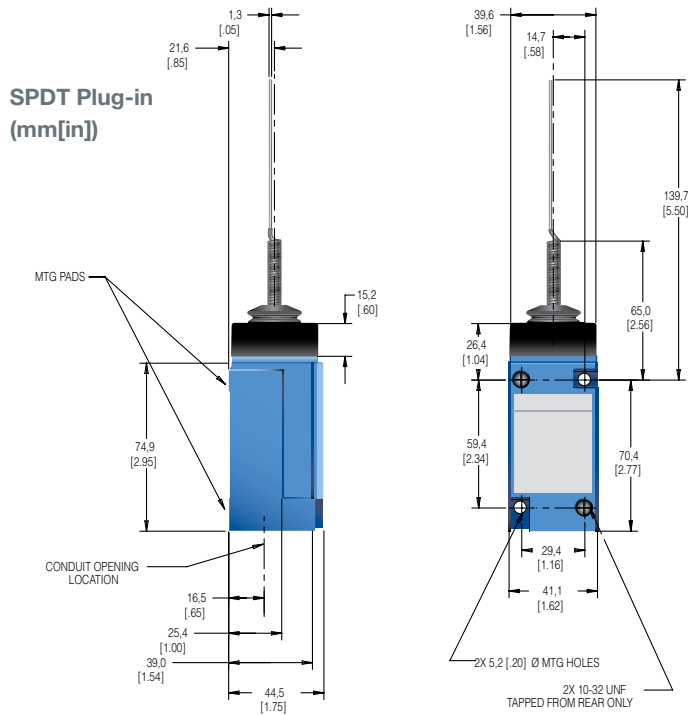
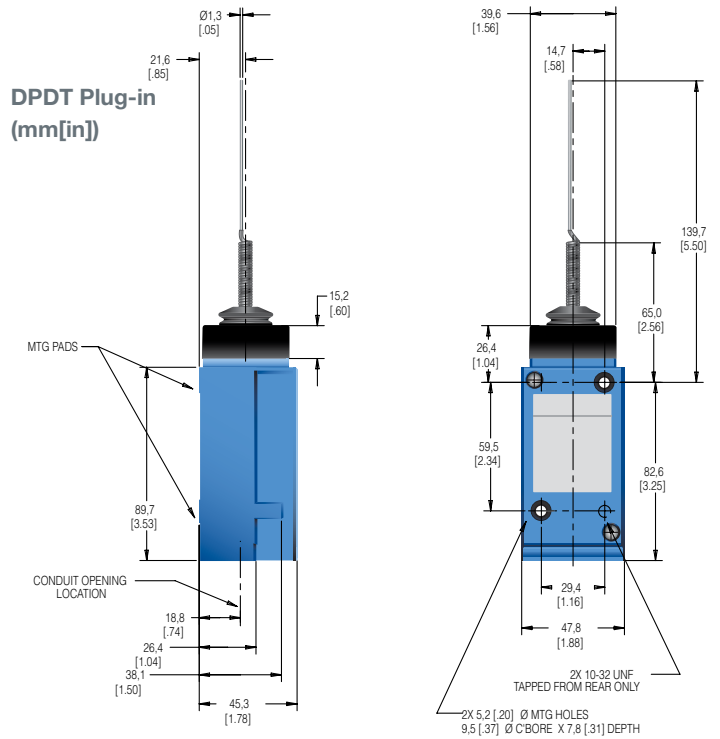
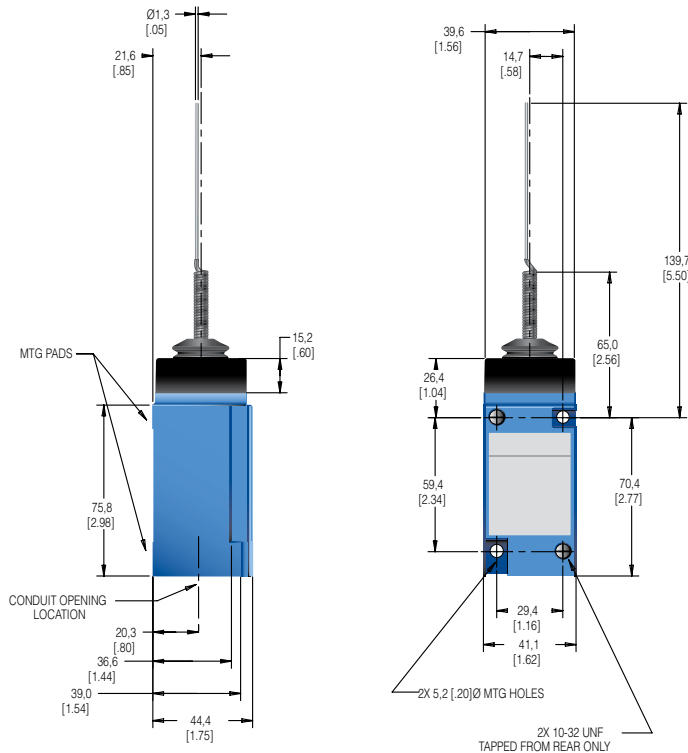


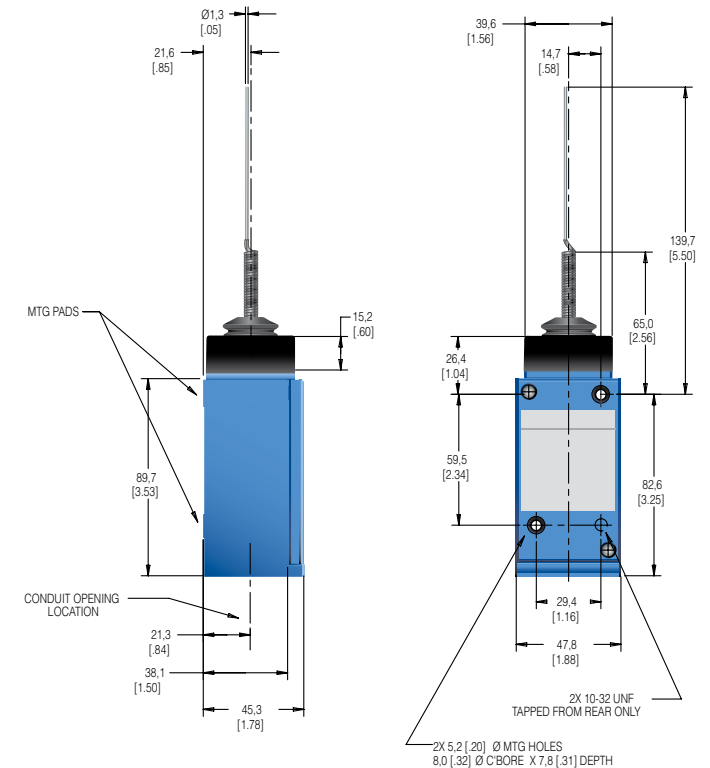
Figure 31. MICRO SWITCH™ HDLS LSK\_\_-8A Series wobble (double pole) dimensions



SPDT Non-plug-in (mm[in])

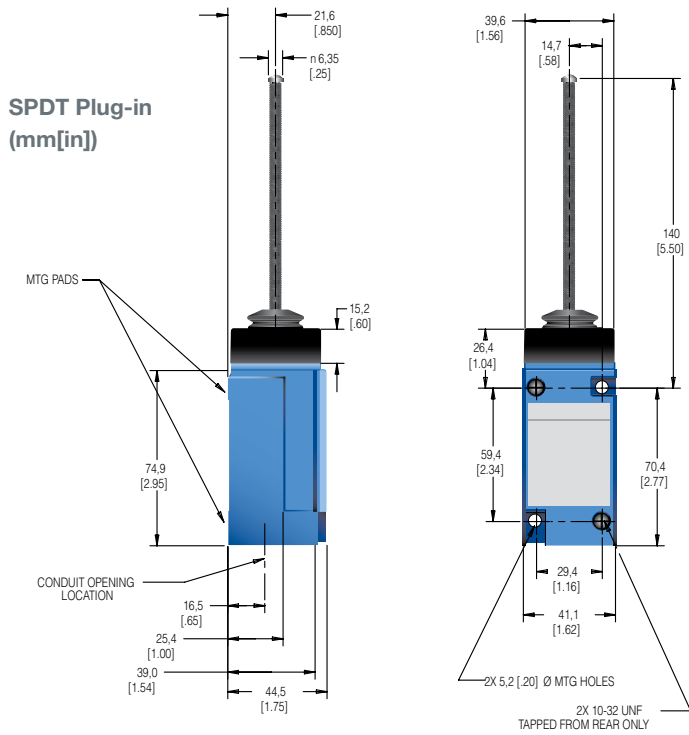


DPDT Non-plug-in (mm[in])

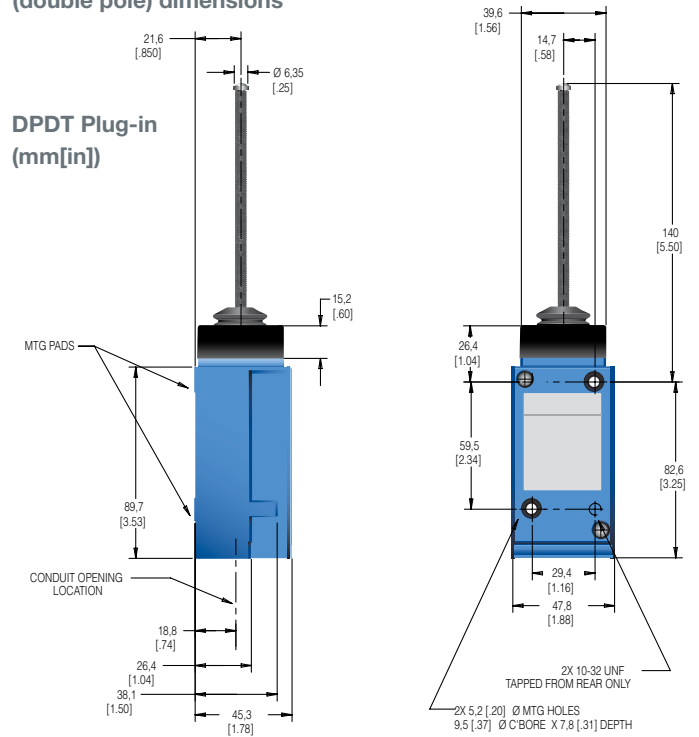


# HDLS Series

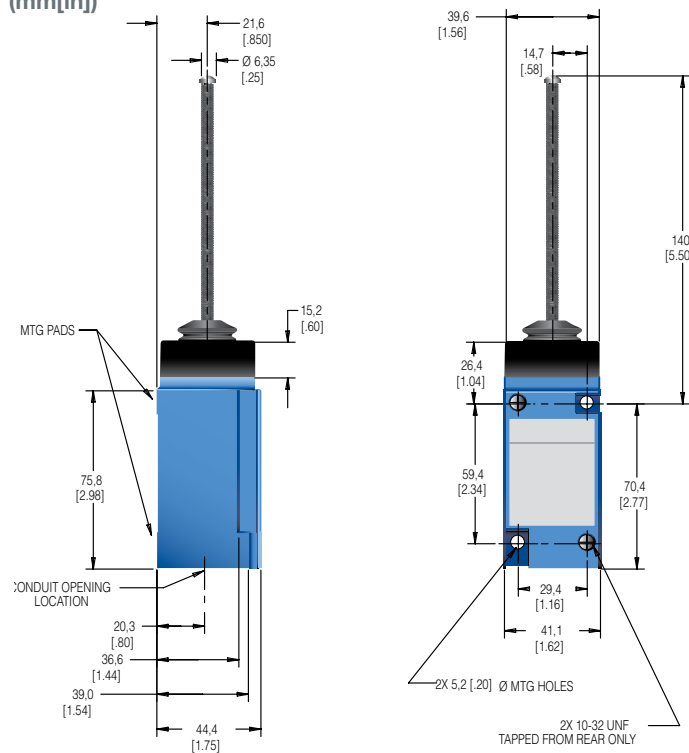
**Figure 32. MICRO SWITCH™ HDLS LSK\_\_-8C Series wobble (single pole) dimensions**



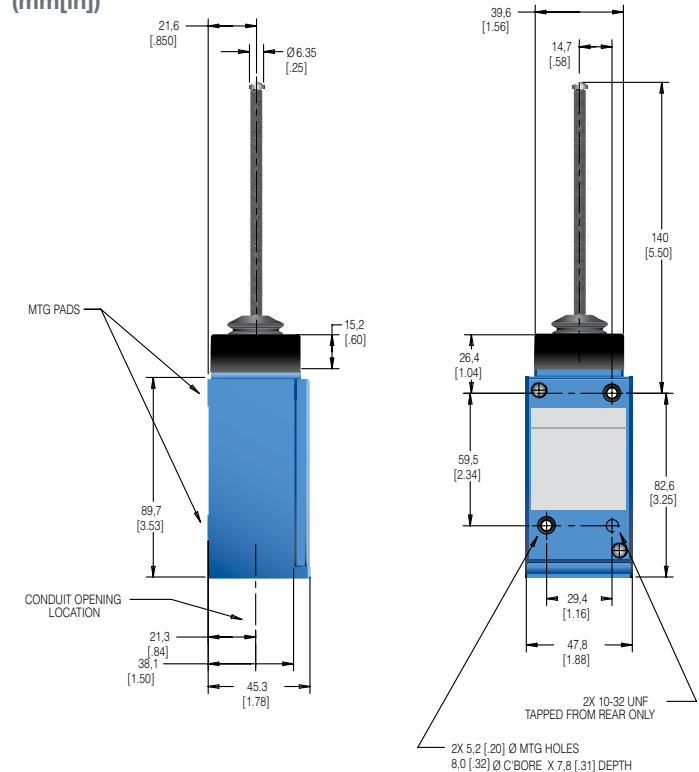
**Figure 33. MICRO SWITCH™ HDLS LSK\_\_-8C Series wobble (double pole) dimensions**



**SPDT Non-plug-in (mm[in])**



**DPDT Non-plug-in (mm[in])**



# MICRO SWITCH™ Heavy-Duty Limit Switches

## SPECIAL APPLICATIONS

### HIGH CAPACITY LIMIT SWITCH

#### Features

- High dc current ratings
- 20 A rating at 120 Vac (single pole)
- Plug-in or non-plug in
- Positive retention lever arm
- High resistance to seismic shock

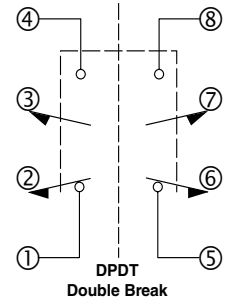
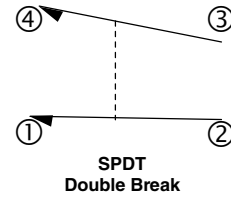


This series has a wide gap contact block that handles a higher make/break dc load. In addition, a special lever arm has a serrated shaft hole and a cap screw with locking nut for attaching the lever to the rotary shaft. This assures a firm grip on the operating shaft and positive retention of the lever adjustment.

The need for precise operation, coupled with challenging environmental conditions places rigid demands on any control. Honeywell's products are intended to satisfy these demands with its high capacity HDLS, designed to perform reliably under these conditions.

#### Listings

<b>LSQ051</b>	Double pole, non-plug-in, 0.75 in conduit	
<b>LSQ052</b>	Double pole, plug-in, 0.75 in conduit	
<b>LSQ053</b>	Single pole, non-plug-in, 0.5 in conduit	
<b>LSQ054</b>	Single pole, plug-in, 0.5 in conduit	
<b>LSZ616</b>	Replacement lever for above listings	
<b>Pretravel</b>	17° max.	
<b>Diff. travel</b>	8° max.	
<b>Overtravel</b>	58° min.	
<b>Oper. torque</b>	0,45 Nm [4 in-lb] max.	
<b>Action</b>	CW and CCW (spring return)	



Voltage	Single Pole		Double Pole	
	Resistive Load	Inductive Load	Resistive Load	Inductive Load
125 Vdc	2.0 A	1.0 A	1.0 A	0.4 A
250 Vdc	0.7 A	0.4 A	0.4 A	0.2 A
120 Vac	20 A	20 A	10 A	10 A
240 Vac	15 A	15 A	7.5 A	7.5 A
480 Vac	10 A	10 A	5 A	5 A
600 Vac	5 A	5 A	2.5 A	2.5 A

Maximum operating rate - 15 operations per minute.

NOTE: Same polarity each pole.



# HDLS Series

## SPECIAL APPLICATIONS

### GRAVITY RETURN SIDE ROTARY SWITCHES (LSS)

LSS1H gravity-return, side-rotary switches have no return spring mechanism. The weight of the actuating lever must provide the force to restore it to the free position. The 5 in-oz. max. operating torque is useful in conveyor applications since it enables operation by small or lightweight objects. Because the head is unsealed, the **LSS1H** is classified as NEMA 1. However, the switch cavity is sealed to protect the switch contacts.

	LSS1H
<b>Description</b>	Gravity-return side rotary
<b>Circuitry</b>	SPDT, double break
<b>Contacts</b>	Silver
<b>Sealing</b>	NEMA 1
<b>Electrical rating</b>	(B) NEMA B600
<b>Body style</b>	Plug-in
<b>Conduit (NPT)</b>	0.5 in
<b>Differential travel</b>	12° max.
<b>Total travel (no stop)*</b>	360°
<b>Operating torque</b>	0,035 Nm [5 in-oz] max.



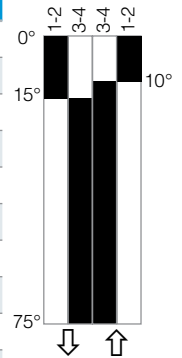
\* Switch has approximately 180° dwell of the normally closed and normally open switch contacts.

NOTE: Same polarity each pole.

### EXTRA LOW TORQUE SIDE ROTARY SWITCHES (LST)

LST1H extra-low torque, side-rotary switches have a low force return spring and a maximum operation torque of 12 in-oz. It is rated as NEMA 1 due to an unsealed head. The switch cavity is sealed to protect the switch contacts.

	LST1H
<b>Description</b>	Extra-low torque side rotary
<b>Circuitry</b>	SPDT, double break
<b>Contacts</b>	Silver
<b>Sealing</b>	NEMA 1
<b>Electrical rating</b>	(B) NEMA B600
<b>Body style</b>	Plug-in
<b>Conduit (NPT)</b>	0.5 in
<b>Pretravel</b>	15° max.
<b>Differential travel</b>	5° max.
<b>Overtravel</b>	60' min.
<b>Total travel</b>	75° nom.
<b>Operating torque</b>	0,085 Nm [12 in-oz] max.



NOTE: Same polarity each pole.

# MICRO SWITCH™ Heavy-Duty Limit Switches

This datasheet supports the following MICRO SWITCH™ HDLS Series Heavy-Duty Limit Switches.

LS2A4K	LS4K1A-8A	LSA3K-1N	LSB2R	LSG1E	LSK6B-8C	LSP1A-2A
LS2A4KC	LS4K1A-8C	LSA3K-2A	LSB3K	LSG2B	LSK7L-8A	LSP1A-2D
LS2A4KPC	LS4L6C	LSA3K-2B	LSB3K-1B	LSG3K	LSK7L-8B	LSP1A4
LS2A4KY-FP	LS4M2D	LSA3K-2C	LSB3K-1D	LSG4L	LSK7L-8C	LSP1A-4M
LS2A4L	LS4N1A	LSA3K-2D	LSB3K-2C	LSG5A	LSK8A-8A	LSP1A5-1C
LS2A4L-RS	LS4N2B	LSA3K-2J	LSB4L	LSG6B	LSK8A-8B	LSP1AB
LS2A4LX-FP	LS4P1A	LSA3K3	LSB5A	LSG7L	LSK8A-8C	LSP1E
LS2C4L	LS4W1A	LSA3K4	LSB5A-2D	LSG9A	LSK9A-8C	LSP1E-1A
LS2D3N	LS4YAC1A	LSA3K4-1A	LSB6B	LSH1A	LSL2C	LSP1F
LS2D4K	LS4YDC1E	LSA3K4-1B	LSB6B-4N	LSH1A-1B	LSL2C-2D	LSP2B
LS2D4KC	LS4YEC1A	LSA3K4-1D	LSB7L	LSH1A2	LSL2G	LSP2B-1B
LS2D4L	LS4YJC1A-7N	LSA3K-4M	LSB7L-1B	LSH1A-2B	LSL4M	LSP3K
LS2D4LM	LSA1A	LSA3K-4N	LSB9A	LSH1A-2D	LSL4M4	LSP3K-1B
LS2D4L-RS	LSA1A1	LSA3K-4R	LSC1A	LSH1AB	LSL6C	LSP3K-1D
LS2E4K	LSA1A1-1A	LSA3K-5C	LSC1E	LSH1E	LSL6C-4N	LSP3K3
LS2E4L	LSA1A1-1B	LSA3KA	LSC2B	LSH1E-1A	LSL7M	LSP4L
LS2F4K	LSA1A1-2J	LSA3KC	LSC2C	LSH2B	LSL7M-1P	LSP4L-4N
LS2F4L	LSA1A13	LSA3N	LSC3K	LSH2B-1B	LSM2D	LSP4L5
LS2F4L5	LSA1A14	LSA3N14-2J	LSC3KC	LSH2B-2D	LSM2D-1A	LSP5A
LS2H3K	LSA1A15	LSA4L	LSC4L	LSH3K	LSM2D-1B	LSP5A7
LS2H4K	LSA1A-1A	LSA4L1	LSC5A	LSH4L	LSM2D-1D	LSP6B
LS2H4L	LSA1A-1B	LSA4L-1A	LSC6B	LSH4L13	LSM2D-2D	LSP7L
LS2H4L3	LSA1A-1C	LSA4L-1B	LSC7L	LSH4L-1B	LSM2D-2J	LSP7L-2D
LS2M4N	LSA1A-1D	LSA4L-1D	LSC8A	LSH4L3	LSM2DM	LSP7L3
LS2M4N3	LSA1A-1F	LSA4L23	LSD1A	LSH5A	LSM2H	LSP7S3
LS2M4NM	LSA1A-1L	LSA4L-2A	LSD1A6	LSH5A-1L	LSM2U	LSP8A
LS2N3K	LSA1A-1M	LSA4L-2B	LSD1E	LSH5A-4N	LSM4N	LS-PA5A4
LS2YAB4K	LSA1A1S	LSA4L3-1D	LSD1F	LSH6B	LSM4N-1A	LSPA5D2
LS2YAB4L	LSA1A2	LSA4L4	LSD2B	LSH6B-1B	LSM4N-1B	LSPA5D4
LS2YAB4L5M	LSA1A2-2J	LSA4L4-1D	LSD2F	LSH7L	LSM4N-2B	LSQ037
LS2YCB4K	LSA1A-2A	LSA4S	LSD3K	LSH9A	LSM6D	LSQ038
LS2YDB4K	LSA1A-2B	LSA5A	LSD3K6	LSH9A7	LSM6D-1B	LSQ051
LS2YEB4K	LSA1A-2C	LSA5A15	LSD4L	LSJ1A	LSM6D-1D	LSQ052
LS2YMB4N	LSA1A-2D	LSA5A-1A	LSD5A	LSJ1A-1N	LSM6D-1P	LSQ053
LS2Z1A	LSA1A-2E	LSA5A-1B	LSD5A7	LSJ1A-7A	LSM6D-2A	LSQ054
LS2Z1AB	LSA1A-2J	LSA5A-1C	LSD6B	LSJ1A-7M	LSM6D-2B	LSQ081
LS2Z1D	LSA1A-2K	LSA5A-1D	LSD7L	LSJ1A-7N	LSM6D3	LSQ117-QC
LS2Z1E	LSA1A3	LSA5A25	LSD8A	LSJ1AB-7N	LSM6D4-5D	LSQ2A4L352
LS2Z1F	LSA1A3-1B	LSA5A7B	LSD9A	LSJ1AC-7M	LSM6D-5B	LSQ2H4KP227
LS2Z1H	LSA1A3-5C	LSA5AB-1A	LSE1A	LSJ1AC-7N	LSM6U	LSQ2L4M321
LS2Z1N	LSA1A4	LSA5AB-1B	LSE1A3	LSJ1ADD-7A	LSM7N	LSQ300
LS2Z51A	LSA1A-4	LSA5ADD	LSE1A4	LSJ1E-7A	LSM7N-1A	LSQ310-20
LS2Z51B	LSA1A-4M	LSA6B	LSE1A5	LSJ1E-7M	LSM7N-1B	LSQ3A3K281-VL363
LS2Z51D	LSA1A-4N	LSA6B1	LSE1ADD	LSJ2B-7A	LSM7N-1D	LSQ3N2D3357
LS2Z51R	LSA1A-4R	LSA6B-1A	LSE1E	LSJ2B-7M	LSM7N3	LSQA1A278
LS2Z52A	LSA1A5	LSA6B-1B	LSE1E4	LSJ2B-7N	LSM7N-4	LSQA1A313
LS2Z52B	LSA1A-9B	LSA6B-1D	LSE2B	LSJ3K	LSM7U	LSQA1A366
LS2Z52D	LSA1AA	LSA6B-1F	LSE3K	LSJ3K-7A	LSM7U-2D	LSQA3K129
LS2Z54N	LSA1AB	LSA6B-1L	LSE4L	LSJ3K-7M	LSN1A	LSQA3K163
LS2Z54N-C	LSA1AB-1B	LSA6B-2B	LSE5A	LSJ3K-7N	LSN1A-1B	LSQA3K363
LS2Z616	LSA1AC	LSA6B-2C	LSE6B	LSJ4L-7A	LSN1A-2C	LSQA6B134
LS30218	LSA1AC-2C	LSA6B-2D	LSE6B5	LSJ4L-7M	LSN1A-3A	LSQA6B314
LS3A1A	LSA1AC-4M	LSA6B-3D	LSE6C5	LSJ5A-7A	LSN1A-3B	LSQD3K-SCO
LS3A2B	LSA1AH12	LSA6B4-2C	LSE6S	LSJ5A-7M	LSN1A-3D	LSQE3K318
LS3A3K	LSA1E	LSA6R	LSE7L	LSJ5A-7N	LSN1A-3P	LSQH1A322
LS3A3K-7AA	LSA1E-1B	LSA6S	LSE7L3	LSJ6B	LSN1A-3S	LSQJ1A213
LS3A3K-7AA-RS	LSA1E-2A	LSA7L	LSE9A	LSJ6B-7A	LSN1E	LSQL7M122
LS3D3K	LSA1E-2D	LSA7L-1A	LSF1A	LSJ6B-7M	LSN1E-1A	LSQL7M123
LS3F1A8	LSA1F	LSA7L-1B	LSF1A3	LSJ6B-7N	LSN1F	LSQM6D315
LS3F1E	LSA2B	LSA7L-1C	LSF1A4	LSJ7L-7A	LSN1F-1B	LSQMC7N147
LS3M2D	LSA2B15-5D	LSA7L-1D	LSF1A5	LSJ7L-7M	LSN2B	LSQMC7N148
LS3YDC1A	LSA2B-1A	LSA7L-2D	LSF1A8	LSJ7L-7N	LSN3K	LSQMC7N311
LS3YDC1E	LSA2B-1B	LSA7L-2J	LSF1E	LSJ8A-7A	LSN4L	LSQR1A316
LS3YVC1A	LSA2B-1C	LSA7L3-1B	LSF1F	LSK1A	LSN4L-2D	LSQUB1A323
LS3YVC1E	LSA2B-1D	LSA7L4	LSF2B	LSK1A-8A	LSN4L-3B	LSQUC3K170
LS4A1A	LSA2B25-5D	LSA7L-4N	LSF2C	LSK1A-8B	LSN4L-3D	LSQUC5K272
LS4A1E	LSA2B-2A	LSA7L-4R	LSF3K	LSK1A-8C	LSN5A	LSQYAB1AC365
LS4A1J	LSA2B-2B	LSA7L-5C	LSF3K3	LSK1E-8A	LSN6B	LSQYAB4L347
LS4A2B	LSA2B-2C	LSA8A	LSF3K4	LSK1E-8C	LSN6B-3B	LSQYAB4LX249
LS4A3K	LSA2B-2D	LSA8A7	LSF3K5	LSK1J-8C	LSN7L	LSQYDB3K356
LS4A3K-1B	LSA2B3-5C	LSA9A	LSF3K8	LSK2B-8A	LSN8A	LSQYFB1A344
LS4A3K-2B	LSA2B4	LSA9A-1A	LSF3N	LSK2B-8C	LSN8A37	LSQYFB3K125-QC
LS4A3K-7AA	LSA2B5	LSA9A23	LSF4L	LSK3K	LSN9A	LSQYFB3K345
LS4C1A	LSA2F	LSA9A-2L	LSF5A	LSK3K-8A	LSN9EDD	LSQYFC3K223
LS4C3K	LSA2R	LSA9ADD	LSF6B	LSK3K-8B	LSP1A	LSQYJB1A346
LS4D1A	LSA2S	LSA9EDD	LSF6B3	LSK3K-8C	LSP1A-1B	LSQYMC7N361
LS4D3K	LSA3K	LSB1A	LSF7L	LSK4L-8A	LSP1A-1C	LSQYPB3KP364
LS4F1A	LSA3K1	LSB1A1	LSF7L3	LSK4L-8C	LSP1A-1D	LSQYUB1A334
LS4F2B	LSA3K1-1A	LSB1A-1B	LSF7L4	LSK5A-8A	LSP1A2	LSQYUB3K336
LS4H1A	LSA3K1-1B	LSB1A-4M	LSF7L5	LSK5A-8B	LSP1A25	LSQYUB3K339
LS4J1A-7A	LSA3K-1A	LSB1A-4N	LSF7L8	LSK5A-8C		LSQYUB3KC319
LS4J1A-7M	LSA3K-1B	LSB1AC	LSF8A	LSK6B		
LS4J1A-7N	LSA3K1C-1C	LSB1E	LSF9A	LSK6B-8A		
LS4J2B-7N	LSA3K-1D	LSB2B	LSG1A	LSK6B-8B		

# HDLS Series

LSQZ52J	LSYAB3K-2J	LSYCB9A7	LSYJB1E-7A	LSYNB3K	LSYVC3KY-FP	LSZ59
LSQZ55C259	LSYAB3K-5D	LSYCC1A	LSYJB1E-7M	LSYNB3K-3S	LSYVC7L	LSZ59A
LSR1A	LSYAB3KE-FP	LSYCC1ADD	LSYJB1J-7A	LSYNB3K5-3S	LSYWB1A	LSZ59AC
LSR1A-1A	LSYAB3KPC-FP	LSYCC1ADD-C	LSYJB2B-7M	LSYNB3KP-FP	LSYWB3K	LSZ59B
LSR1A-1B	LSYAB3KP-FP	LSYCC1AE	LSYJB3K-7A	LSYNB3KQ-3BFP	LSYWB3KQ-FP	LSZ59C
LSR1A-2K	LSYAB3KQ-FP	LSYCC3K	LSYJB3K-7M	LSYNB4L	LSYWC1A	LSZ59D
LSR1A-4N	LSYAB3N	LSYCC3KP-FP	LSYJB3K-7N	LSYNB4L-3P	LSYWC1ADD	LSZ59L
LSR1A-5C	LSYAB3N-4N	LSYCC3KQ-FP	LSYJB3KQ-7MFP	LSYNB4LX-FP	LSYWC1F	LSZ60A
LSR1ADD	LSYAB4L	LSYCC3KY-FP	LSYJB4L-7M	LSYNB5A	LSYWC3KP-FP	LSZ60B
LSR1E	LSYAB4L-1B	LSYCC4L	LSYJB4LX-7AFP	LSYNB7L	LSYWC3KY-FP	LSZ61
LSR2B	LSYAB4L24	LSYCC4LX-FP	LSYJB5A-7A	LSYNC1A	LSYWC5KQ-FP	LSZ616
LSR2B-4N	LSYAB4L24-1	LSYCC5A	LSYJB6B-7M	LSYNC1ADD	LSYWC6B	LSZ617
LSR3K	LSYAB4L-2A	LSYCC5KP-FP	LSYJC1A-7A	LSYNC1E	LSYWC7L	LSZ618
LSR3K1	LSYAB4L360	LSYCC5KY-FP	LSYJC1A-7M	LSYNC3KPC-FP	LSYWC7L	LSZ618
LSR3K-4M	LSYAB4L4	LSYCC6B	LSYJC1A-7N	LSYNC3KP-FP	LSZ51	LSZ65AA
LSR4L	LSYAB4LX-FP	LSYCC7L	LSYJC1AC-7M	LSYNC3KQ-FP	LSZ51A	LSZ65AB
LSR5A	LSYAB4S	LSYDB1A	LSYJC1ADD-7A	LSYNC3KQ-FP	LSZ51B	LSZ65AF
LSR6B	LSYAB5A	LSYDB2B	LSYJC1ADD-7N	LSYNC4LX-FP	LSZ51B-C	LSZ65BA
LSR6B-2D	LSYAB6B	LSYDB3K	LSYJC3K-7A	LSYNC5KQ-FP	LSZ51C	LSZ65CA
LSR6B-2L	LSYAB6B-1B	LSYDB4L	LSYJC3K-7N	LSYPB1A	LSZ51CA	LSZ65CB
LSR6B-4M	LSYAB6B-2D	LSYDB6B	LSYJC3K-7AFP	LSYPB1AC	LSZ51D	LSZ65CD
LSR7L	LSYAB7L	LSYDB7L	LSYJC3KP-7MFP	LSYPB1E	LSZ51D-C	LSZ65DA
LSR7L-2D	LSYAB7L-1A	LSYDC1A	LSYJC3KQ-7AFP	LSYPB2B	LSZ51F	LSZ65DB
LSR9A	LSYAB7L-2B	LSYDC1ADD	LSYJC3KQ-7MFP	LSYPB2B-4N	LSZ51G	LSZ65DD
LSS1H	LSYAC1A	LSYDC1ADD-C	LSYJC3KQ-7NFP	LSYPB3K	LSZ51J	LSZ65DD
LSS1H-4N	LSYAC1A1-1D	LSYDC1AE	LSYJC5KQ-7MFP	LSYPB3K3	LSZ51L	LSZ65EA
LSS1HDD	LSYAC1A-1B	LSYDC3K	LSYJC6B-7M	LSYPB3K4	LSZ51M	LSZ65EB
LSS1HDD-C	LSYAC1A2C	LSYDC3KPC-FP	LSYJC7LR-7MFP	LSYPB3KP-FP	LSZ51N	LSZ65ED
LST1H	LSYAC1A-2D	LSYDC3KP-FP	LSYJC7LR-7NFP	LSYPB4L	LSZ51P	LSZ65EE
LST1H-1C	LSYAC1A-4N	LSYDC3KQ-FP	LSYKB1A-8A	LSYPB4L-1B	LSZ51R	LSZ65FA
LSU1A	LSYAC1A-C	LSYDC3KY-FP	LSYKB1A-8C	LSYPB4L3	LSZ51T	LSZ65FB
LSU1A-1	LSYAC1ADD	LSYDC4LX-FP	LSYKB3K-8C	LSYPB4L-4N	LSZ51U	LSZ65FD
LSU1A-1B	LSYAC1ADD-1B	LSYDC5A	LSYKB4L-8C	LSYPB6B	LSZ51W	LSZ65FF
LSU1A-1D	LSYAC1ADD-4N	LSYDC5AC	LSYKB4LM-8C	LSYPB7L	LSZ51Y	LSZ65GA
LSU1A-2B	LSYAC1ADD-C	LSYDC5AE	LSYKB6B-8C	LSYPB7L3	LSZ52	LSZ65GB
LSU1A-2D	LSYAC1AH	LSYDC5KP-FP	LSYKB7L-8C	LSYPC1A	LSZ52A	LSZ65HA
LSU1A4	LSYAC1E	LSYDC5KQ-FP	LSYKC1A-8A	LSYPC1J	LSZ52B	LSZ65HB
LSU1A-4R	LSYAC1EC	LSYDC5KY-FP	LSYKC1A-8C	LSYPC2B	LSZ52C	LSZ65HC
LSU1E	LSYAC2B	LSYDC6B	LSYKC1AC-8A	LSYPC2B-1B	LSZ52D	LSZ65HD
LSU2B	LSYAC2R	LSYDC7L	LSYKC1AC-8C	LSYPC3K	LSZ52E	LSZ65HE
LSU3K	LSYAC2S	LSYDC9KP-FP	LSYKC1ADD-8C	LSYPC3KP-FP	LSZ52J	LSZ65JA
LSU3K1	LSYAC3K	LSYEB4L5	LSYKC1ADD-8C-C	LSYPC3KQ-FP	LSZ52K	LSZ65JB
LSU3K-1A	LSYAC3KC-FP	LSYEC1A	LSYKC1E-8C	LSYPC3KY-FP	LSZ52L	LSZ65JD
LSU3K-2J	LSYAC3KDD-FP	LSYEC1ADD	LSYKC3K-8C	LSYPC4LX-FP	LSZ52M	LSZ65JE
LSU4L	LSYAC3KP	LSYEC1ADD-C	LSYKC3K-8AFP	LSYRB1A	LSZ52N	LSZ65JF
LSU5A	LSYAC3KPB-FP	LSYEC1AE	LSYKC3KQ-8CFF	LSYRB3KP-FP	LSZ52R	LSZ65KA
LSU6B	LSYAC3KPC-FP	LSYEC3K	LSYKC4L-8C	LSYRB6B	LSZ52W	LSZ65KB
LSU7L	LSYAC3KP-FP	LSYEC3KP-FP	LSYKC5KQ-8BFP	LSYRC1A	LSZ52Y	LSZ65LA
LSU8A	LSYAC3KQ-1BFP	LSYEC3KQ-FP	LSYKC7LR-8AFP	LSYRC1A3	LSZ53	LSZ65LB
LSU9A	LSYAC3KQ-FP	LSYEC3KY-FP	LSYLB4M	LSYRC1ADD	LSZ53A	LSZ67AA
LSV1A	LSYAC3KQ-FP-C	LSYEC4LX-FP	LSYLB6C	LSYRC1ADD-C	LSZ53B	LSZ68
LSV1E	LSYAC3KY-FP	LSYEC5KP-FP	LSYLB6T	LSYRC1E3	LSZ53D	LSZ686
LSV2B	LSYAC3N	LSYEC5KY-FP	LSYLB7M	LSYRC2B	LSZ53E	LSZ69CA
LSV3K	LSYAC4L	LSYEC6B	LSYLB7MR-FP	LSYRC3KP-FP	LSZ53M	LSZ69DA
LSV4L	LSYAC4L4	LSYFB1A	LSYLB7T	LSYRC4L	LSZ53P	
LSV5A	LSYAC4LAA-FP	LSYFB3K	LSYLC2C	LSYRC4LX-FP	LSZ53S	
LSV6B	LSYAC4LX-FP	LSYFB3K3	LSYLC4M	LSYRC5KP-FP	LSZ53U	
LSV7L	LSYAC5A	LSYFB3K4	LSYLC4MX-FP	LSYRC5KQ-FP	LSZ53W	
LSW1A	LSYAC5KPC-FP	LSYFB4L	LSYLC6C	LSYRC9A	LSZ54	
LSW1A4	LSYAC5KP-FP	LSYFB4LM	LSYMB2D	LSYUB1A	LSZ54M	
LSW1A5	LSYAC5KQ-FP	LSYFB4LX-FP	LSYMB2D3	LSYUB1A13	LSZ54N	
LSW1AC	LSYAC5KY-FP	LSYFB7L	LSYMB4N	LSYUB1A13-2A	LSZ54NA	
LSW1E	LSYAC6B	LSYFC1A	LSYMB4N-1A	LSYUB1A13-2B	LSZ54N-C	
LSW2B	LSYAC6B-1A	LSYFC1ADD	LSYMB4N-2K	LSYUB1A23	LSZ54P	
LSW3K	LSYAC6B-1B	LSYFC1ADD-C	LSYMB4N3X-FP	LSYUB1A23-2D	LSZ54R	
LSW3N	LSYAC6B-2L	LSYFC1AE	LSYMB4NX-FP	LSYUB1A3	LSZ54S	
LSW4L	LSYAC6B-4N	LSYFC3K	LSYMB6D	LSYUB2B	LSZ54T	
LSW5A	LSYAC7L	LSYFC3K	LSYMB6D-2D	LSYUB3K	LSZ54V	
LSW6B	LSYAC7LR-FP	LSYFC3K48P-FP	LSYMB6D-2D	LSYUB6B	LSZ54W	
LSW7L	LSYAC9A	LSYFC3KP-FP	LSYMB6U	LSYUB6B13	LSZ55	
LSYAB1A	LSYAC9AB	LSYFC3KQ-FP	LSYMB7N	LSYUB6B3	LSZ55A	
LSYAB1A-1B	LSYBB1A	LSYFC3KY-FP	LSYMB7N-1C	LSYUB9AC	LSZ55B	
LSYAB1A-2A	LSYBB2B	LSYFC5KQ-FP	LSYMB7N-1D	LSYUC1A	LSZ55C	
LSYAB1A3	LSYBB3K	LSYFC6B	LSYMB7N3	LSYUC1A-1B	LSZ55D	
LSYAB1A-4N	LSYBB3KP-FP	LSYFC7L	LSYMB7N3-1A	LSYUC1ADD	LSZ55E	
LSYAB1AB	LSYBB4L	LSYFC7L3	LSYMB7U	LSYUC2B	LSZ55F	
LSYAB1AC	LSYBB5KP-FP	LSYFC7L4	LSYMC2D-1D	LSYUC3KP-FP	LSZ55K	
LSYAB1E	LSYBC1A	LSYGB1A	LSYMC4N	LSYUC3KQ-FP	LSZ55W	
LSYAB1E-2B	LSYBC3K	LSYGB1E	LSYMC4NX-1BFP	LSYUC3KY-FP	LSZ55Y	
LSYAB1E4-2B	LSYBC3KP-FP	LSYGC3KP-FP	LSYMC4NXB-FP	LSYUC4LX-FP	LSZ56	
LSYAB1EP-1A	LSYBC3KQ-FP	LSYHB1A	LSYMC4NX-FP	LSYUC5KQ-FP	LSZ56A	
LSYAB1F	LSYBC5A	LSYHC1A	LSYMC6D	LSYUC6B	LSZ56B	
LSYAB2B	LSYBC5KP-FP	LSYHC3K	LSYMC6D-1B	LSYUC9ADD	LSZ56C	
LSYAB2B3	LSYBC9A-1D	LSYHC3KA	LSYMC6DF-1B	LSYVB1A	LSZ56D	
LSYAB2F	LSYCB1A	LSYHC3KP-FP	LSYMC6DF-1B	LSYVB2B	LSZ56E	
LSYAB2S	LSYCB1E	LSYHC4L	LSYMC7N	LSYVB3K	LSZ56J	
LSYAB3K	LSYCB3KQ-FP	LSYHC4LX-FP	LSYMC7NDE-FP	LSYVB4L	LSZ56K	
LSYAB3K1	LSYCB4L	LSYHC7L	LSYMC7NR-FP	LSYVC1A	LSZ56L	
LSYAB3K-1B	LSYCB4SX-FP	LSYJB1A-7A	LSYNB1A	LSYVC3KP-FP	LSZ56M	
LSYAB3K2-5C	LSYCB6B	LSYJB1A-7M	LSYNB1AC	LSYVC3KQ-FP	LSZ56N	
		LSYJB1A-7N	LSYNB2B		LSZ581B	

# MICRO SWITCH™ Heavy-Duty Limit Switches

## ALSO AVAILABLE



**Fully potted MICRO SWITCH™ HDLS heavy-duty limit switches** provide an extra degree of protection in harsh environments by sealing the basic switch cavity with epoxy. These switches are the same as the non- plug-in HDLS except that the entire switch cavity is filled with epoxy in addition to the conduit entrance. The fully potted HDLS switches are pre-leaded, with either cable or connectors.

- Excellent sealing capability for harsh-duty food and beverage wash downs and severe machine tool environments
- Diaphragm sealing
- 12 inch STOOW-A cable (other lengths available) or connector version
- Cable versions: NEMA 1, 6, 6P, 12
- Connector versions: NEMA 1, 6, 6P, 12, 13
- All fluorocarbon seals (low temperature fluorosilicone seals available)
- UL, CSA, CE, CCC



**MICRO SWITCH™ HDLS switches are also available in all stainless-steel versions.** Designed for use in highly corrosive environments, such as petrochemical plants, food processing plants, shipboard, and dockside locations. The type 316 cast stainless steel body is designed to minimize crevices where food particles could become trapped in water. The actuator, operating head, and screws are also stainless steel. All seals are fluorocarbon to provide excellent chemical resistance and to withstand operating temperatures up to 121 °C [250 °F] and pressurized steam cleaning. Pre-leaded and epoxy-filled versions also available.

- Corrosion-resistant stainless steel non-plug in body, head, and rotary shaft
- Stainless steel levers
- Fluorocarbon seals (low temperature fluorosilicone seals available)
- NEMA 1, 3, 3R, 4, 4X, 6, 6P, and 13
- UL, CSA, CE, CCC

To learn more about Honeywell's HDLS products, call **+1-815-235-6847** or **1-800-537-6945**.

## ADDITIONAL INFORMATION

The following associated literature is available on the Web at [sensing.honeywell.com](http://sensing.honeywell.com):

- Product installation instructions
- Product range guide
- Product nomenclature tree
- Product application-specific information
  - Application Note: Sensors and Switches in Oil Rig Applications
  - Application Note: Sensors and Switches for Industrial Manual Process Valves
  - Application Note: Sensors and Switches Used in Valve Actuators and Valve Positioners

### **WARNING**

#### **PERSONAL INJURY**

**DO NOT USE** these products as safety or emergency stop devices or in any other application where failure of the product could result in personal injury.

**Failure to comply with these instructions could result in death or serious injury.**

### **WARNING**

#### **MISUSE OF DOCUMENTATION**

- The information presented in this product sheet is for reference only. Do not use this document as a product installation guide.
- Complete installation, operation, and maintenance information is provided in the instructions supplied with each product.

**Failure to comply with these instructions could result in death or serious injury.**

## WARRANTY/REMEDY

Honeywell warrants goods of its manufacture as being free of defective materials and faulty workmanship. Honeywell's standard product warranty applies unless agreed to otherwise by Honeywell in writing; please refer to your order acknowledgement or consult your local sales office for specific warranty details. If warranted goods are returned to Honeywell during the period of coverage, Honeywell will repair or replace, at its option, without charge those items it finds defective. **The foregoing is buyer's sole remedy and is in lieu of all other warranties, expressed or implied, including those of merchantability and fitness for a particular purpose. In no event shall Honeywell be liable for consequential, special, or indirect damages.**

While we provide application assistance personally, through our literature and the Honeywell website, it is up to the customer to determine the suitability of the product in the application.

Specifications may change without notice. The information we supply is believed to be accurate and reliable as of this printing. However, we assume no responsibility for its use.

**Find out more**

Honeywell serves its customers through a worldwide network of sales offices, representatives and distributors. For application assistance, current specifications, pricing or name of the nearest Authorized Distributor, contact your local sales office.

To learn more about Honeywell's sensing and control products, call **+1-815-235-6847** or **1-800-537-6945**, visit **sensing.honeywell.com**, or e-mail inquiries to **info.sc@honeywell.com**

Sensing and Control  
Honeywell  
1985 Douglas Drive North  
Golden Valley, MN 55422  
**honeywell.com**

The Honeywell logo is displayed in a bold, red, sans-serif font.