

Description

The AP8801 is a step-down DC/DC converter designed to drive LEDs with a constant current. The device can drive up to thirteen LEDs, depending on the forward voltage of the LEDs, in series from a voltage source of 8V to 48V. Series connection of the LEDs provides identical LED currents resulting in uniform brightness and eliminating the need for ballast resistors. The AP8801 switches at frequency up to 700kHz. This allows the use of small size external components, hence minimizing the PCB area needed.

Maximum output current of AP8801 is set via an external resistor connected between the V_{IN} and SET input pins. Dimming is achieved by applying either a DC voltage or a PWM signal at the CTRL input pin. An input voltage of 0.2V or lower at CTRL shuts down the output at SW and puts the device into a low-current standby state.

Features

- LED Driving Current up to 500mA
- Operating Input Voltage up to 48V
- High Efficiency up to 92%
- High Switching Frequency up to 700kHz
- PWM/DC Input for Dimming Control
- Built-in Output Open-Circuit Protection
- SO-8 and MSOP-8 are in "Green" Molding Compound (No Br, Sb)
- **Totally Lead-Free & Fully RoHS Compliant (Notes 1 & 2)**
- **Halogen and Antimony Free. "Green" Device (Note 3)**

Notes:

1. No purposely added lead. Fully EU Directive 2002/95/EC (RoHS), 2011/65/EU (RoHS 2) & 2015/863/EU (RoHS 3) compliant.
2. See <https://www.diodes.com/quality/lead-free/> for more information about Diodes Incorporated's definitions of Halogen- and Antimony-free, "Green" and Lead-free.
3. Halogen and Antimony free "Green" products are defined as those which contain <900ppm bromine, <900ppm chlorine (<1500ppm total Br + Cl) and <1000ppm antimony compounds.

Typical Applications Circuit

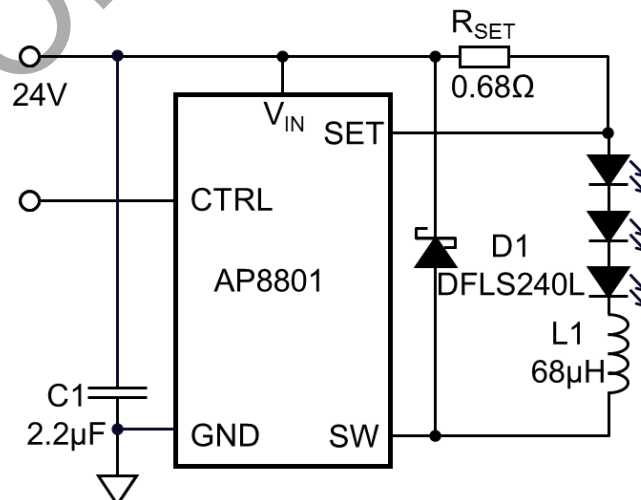

Pin Assignments

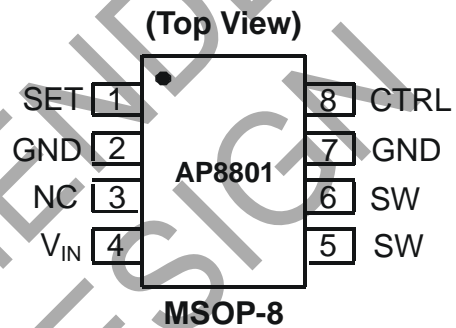
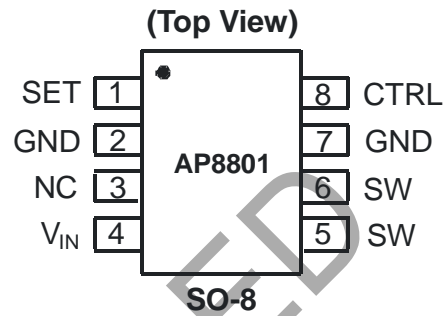

Applications

- Commercial & Industrial Lighting
- Small LCD Panel Backlight
- Appliances Interior Lighting
- Architecture Detail Lighting

Pin Descriptions

Pin Name	Functions
SW	Switch Pin. Connect inductor/freewheeling diode here, minimizing track length at this pin to reduce EMI.
GND	GND pin
SET	Set Nominal Output Current Pin. Configure the output current of the device.
CTRL	<p>Dual Function Dimming Control Pin.</p> <ul style="list-style-type: none"> Input voltage of 0.2V or lower forces the device into low current standby mode and shuts off the output. A PWM signal (driven by an open-drain/collector source) allows the output current to be adjusted over a wide range up to 100%. An analog voltage between 0.3V and 2.5V adjusts the output current between 25% and 200% of the current set by $0.2V/R_S$. <p>The input impedance is about 50kΩ, and if the pin is left open $V_{CTRL} = V_{REF}$</p>
V _{IN}	Input Supply Pin. Must be locally bypassed.
NC	No connection

Functional Block Diagram

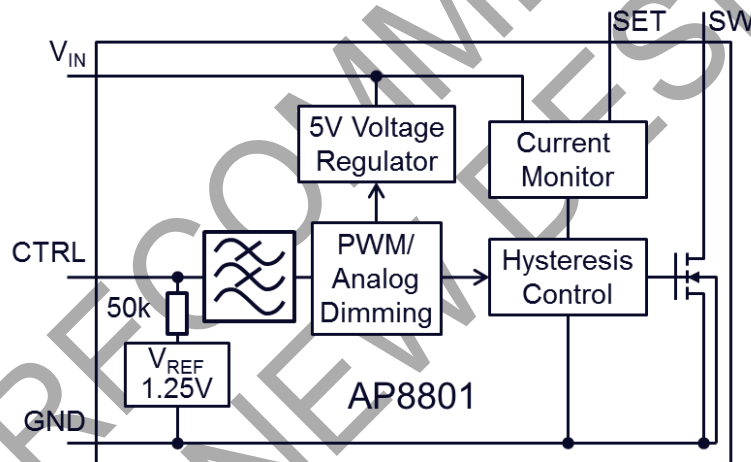

Fig. 1 Block Diagram

Absolute Maximum Ratings (@T_A = +25°C, unless otherwise specified.)

Symbol	Parameter	Rating	Unit
V _{IN}	V _{IN} pin voltage	-0.3 to +50	V
V _{SW}	SW voltage	-0.3 to +50	V
V _{CTRL}	CTRL Pin Input Voltage	-0.3 to +6	V
V _{SENSE}	SET Voltage	+0.3 to -5	V
T _J	Junction Temperature	+150	°C
T _{LEAD}	Lead Temperature Soldering	+300	°C
T _{ST}	Storage Temperature Range	-65 to +150	°C

Caution: Stresses greater than the 'Absolute Maximum Ratings' specified above, may cause permanent damage to the device. These are stress ratings only; functional operation of the device at these or any other conditions exceeding those indicated in this specification is not implied. Device reliability may be affected by exposure to absolute maximum rating conditions for extended periods of time.

Semiconductor devices are ESD sensitive and may be damaged by exposure to ESD events. Suitable ESD precautions should be taken when handling and transporting these devices.

Recommended Operating Conditions (@ $T_A = +25^\circ\text{C}$, unless otherwise specified.)

Symbol	Parameter	Min	Max	Unit
V_{IN}	Operating Input Voltage relative to GND	8.0	48.0	V
V_{CTRLDC}	Voltage range for 24% to 200% DC dimming relative to GND (Note 4)	0.3	2.5	V
V_{CTRLL}	Voltage Low for PWM dimming relative to GND	0	0.2	V
f_{OSC}	Maximum Switching Frequency (Note 5)	—	625	kHz
T_A	Ambient Temperature Range	-40	+105	$^\circ\text{C}$
Duty Cycle	Using Inductor $\geq 100\mu\text{H}$ (Note 6)	0.10	0.95	—

- Notes:
4. For 100% brightness either leave floating or connect to 1.25V relative to GND.
 5. AP8801 will operate at higher frequencies but accuracy will be affected due to propagation delays.
 6. For most applications the LED current will be within 8% over the duty cycle range specified. Duty cycle accuracy is also dependent on propagation delay. Smaller size inductors can be used but LED current accuracy may be greater than 8% at extremes of duty cycle. This is most noticeable at low duty cycles (less than 0.1) or when the input voltage is high and only one LED is being driven.

Electrical Characteristics (@ $T_A = +25^\circ\text{C}$, $V_{IN} = 12\text{V}$, unless otherwise specified.)

Symbol	Parameter	Conditions	Min	Typ	Max	Unit
I_{OUT}	Continuous Switch Current	(Note 7)	—	—	500	mA
I_Q	Quiescent Current	—	—	78	120	μA
V_{THD}	Internal Threshold Voltage	—	184	200	216	mV
$V_{SENSEHYS}$	Sense Threshold hysteresis	—	—	15	—	%
V_{REF}	Internal Reference Voltage	—	—	1.25	—	V
SET	SET Pin Input Current	$V_{SET} = V_{IN} - 0.2$	—	7	—	μA
$R_{DS(ON)}$	On Resistance of MOSFET	$I_{SW} = 0.4\text{A}$	—	0.70	1.15	Ω
$I_{SW_LEAKAGE}$	Switch Leakage Current	—	—	—	8	μA
θ_{JA}	Thermal Resistance Junction-to-Ambient	SO-8 (Note 8)	—	88	—	$^\circ\text{C/W}$
		MSOP-8 (Note 8)	—	128	—	$^\circ\text{C/W}$
θ_{JC}	Thermal Resistance Junction-to-Case	SO-8 (Note 8)	—	58	—	$^\circ\text{C/W}$
		MSOP-8 (Note 8)	—	90	—	$^\circ\text{C/W}$

- Notes:
7. Refer to figure 6 for the device derating curve.
 8. Test condition for SO-8 and MSOP-8: Device mounted on FR-4 PCB, 2"x2", 2oz copper, minimum recommended pad layout on top layer and thermal vias to bottom layer ground plane. For better thermal performance, larger copper pad for heat-sink is needed.

Typical Characteristics

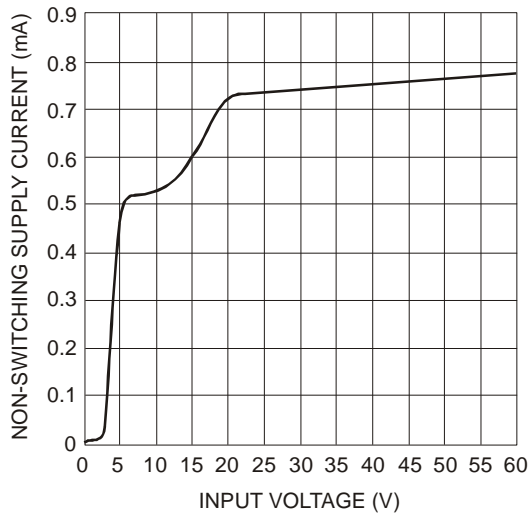

Figure 2 Supply Current (not switching) vs. Input Voltage

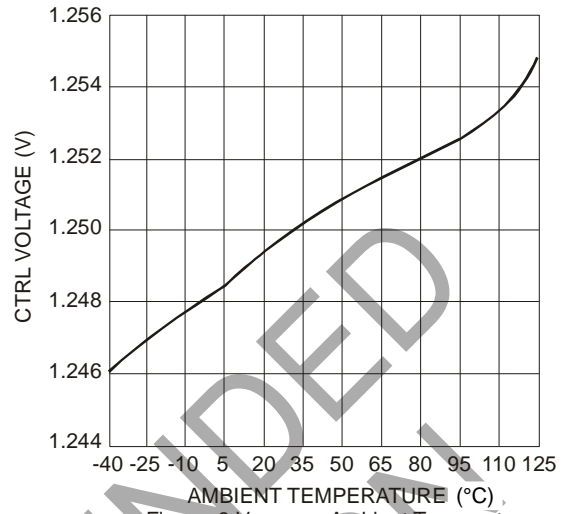

Figure 3 V_{CTRL} vs. Ambient Temperature

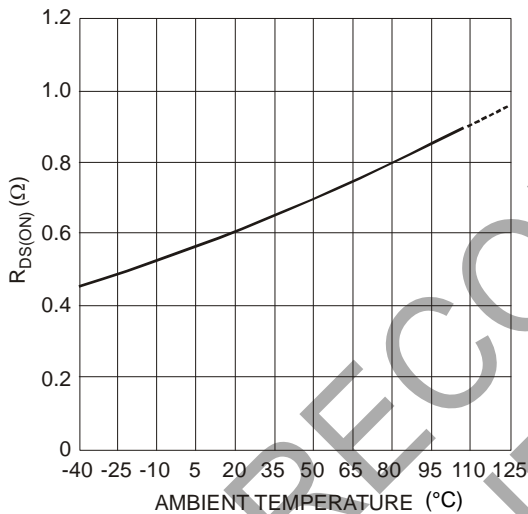

Figure 4 $R_{DS(ON)}$ vs. Ambient Temperature

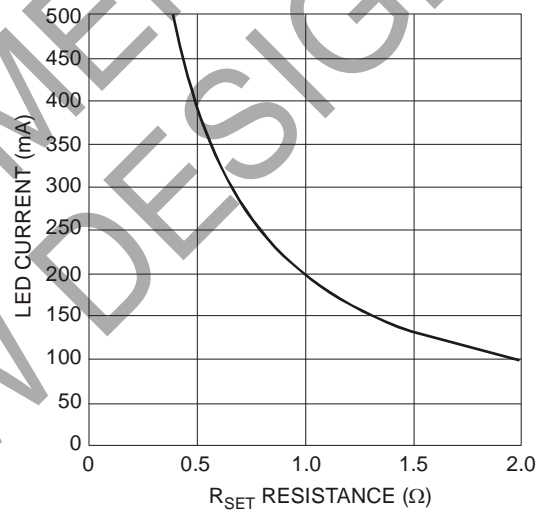

Figure 5 LED Current vs. R_{SET}

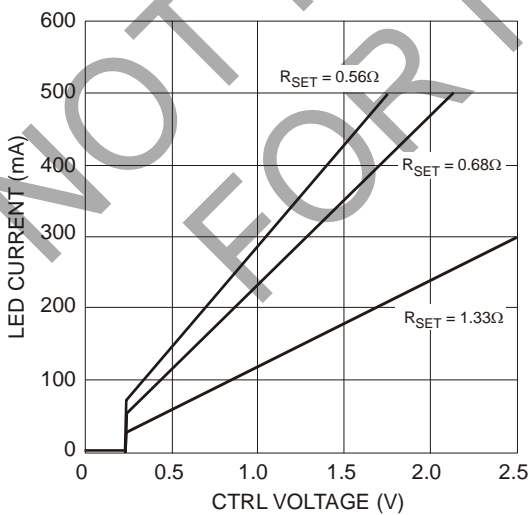

Figure 6 LED Current vs. V_{CTRL}

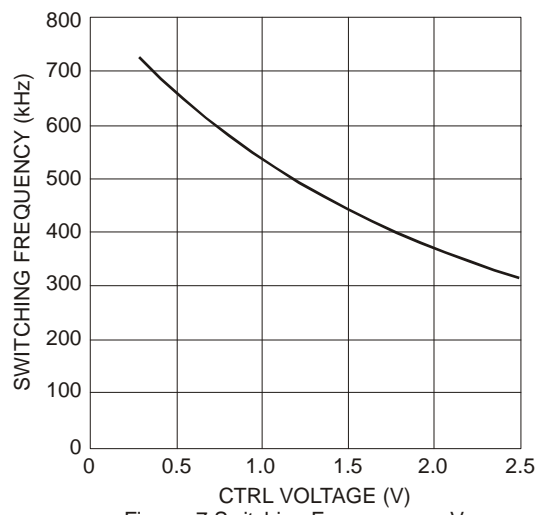

Figure 7 Switching Frequency vs. V_{CTRL}

Typical Characteristics ($T_A = +25^\circ\text{C}$, $V_{IN} = 60\text{V}$, $L = 68\mu\text{H}$ unless otherwise stated.)

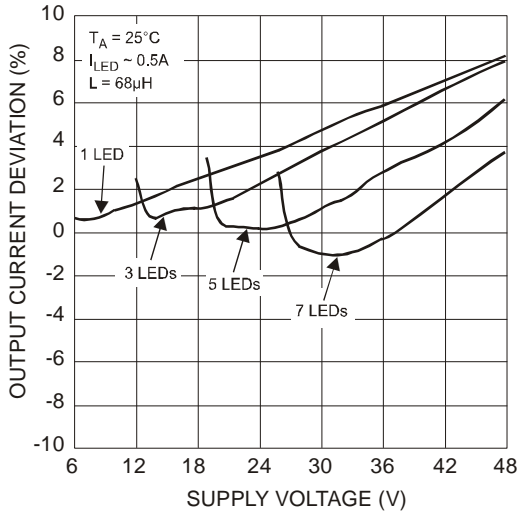

Figure. 8 LED Current vs. Input Voltage

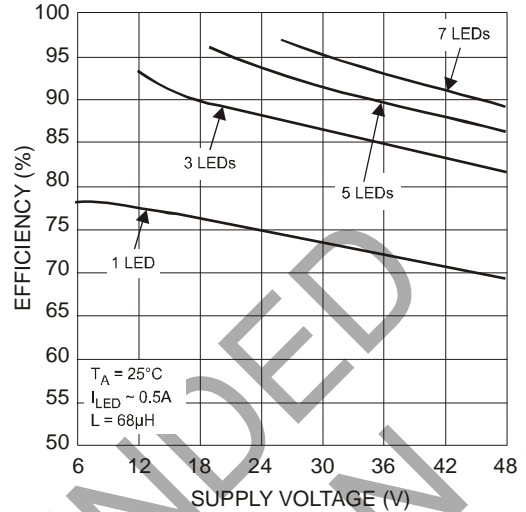

Figure. 9 Efficiency vs. Input Voltage

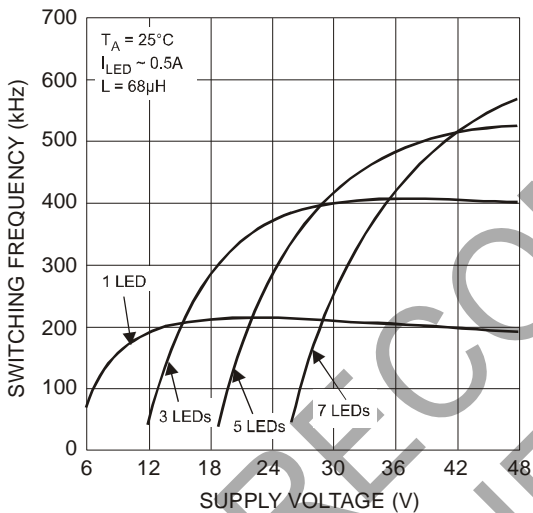

Figure. 10 Switching Frequency vs. Input Voltage

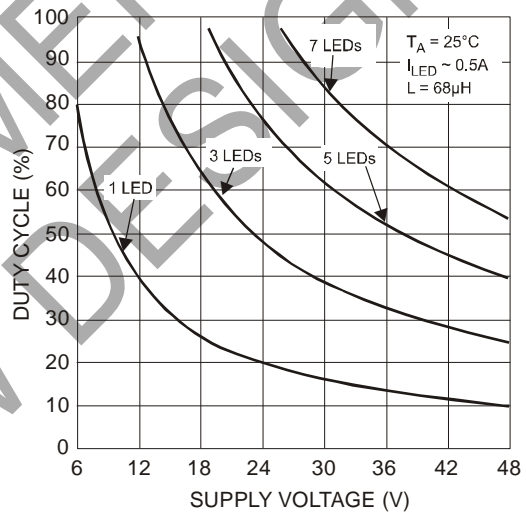

Figure. 11 Duty Cycle vs. Input Voltage

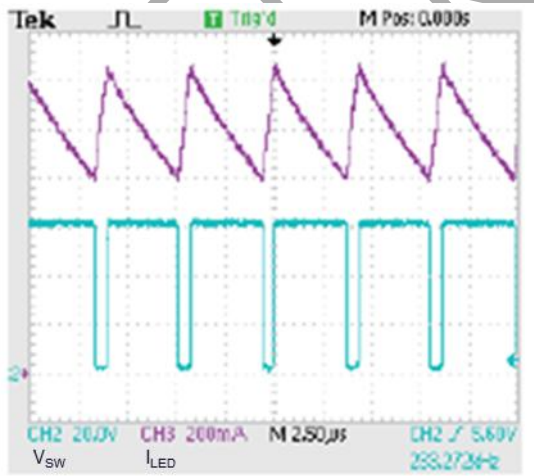

Figure. 12 Steady State Waveforms

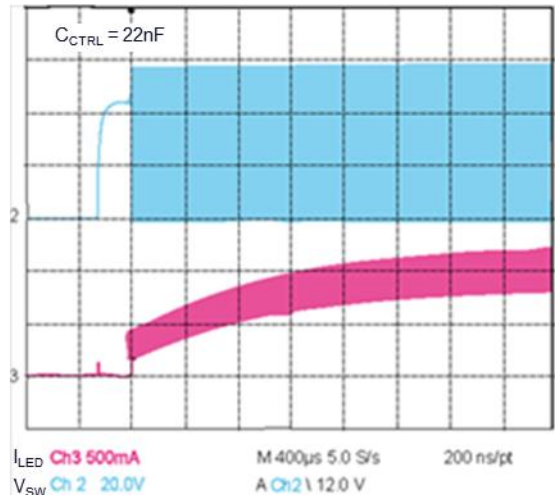

Figure.13 Start-Up Showing LED Current Soft -Start

Application Information

LED Current Control

The LED current is controlled by the resistor R_{SET} in Figure 14 connected between V_{IN} and SET. The nominal average output current in the LED(s) is defined as:

$$I_{LED} = \frac{V_{THD}}{R_{SET}}$$

where V_{THD} is the voltage between the V_{IN} and SET pins and is nominally 200mV.

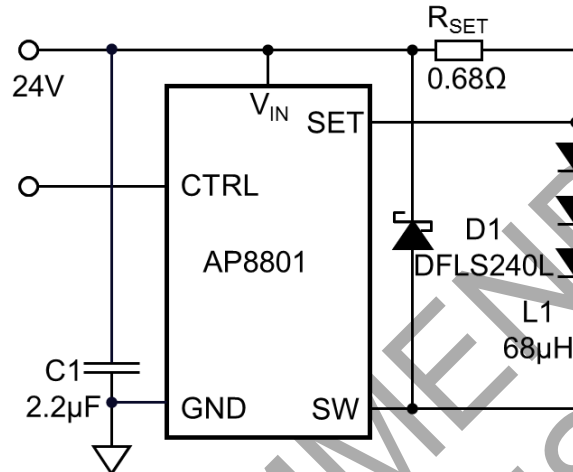

Figure. 14 Typical Application Circuit for $I_{LED} = 0.3A$

Inductor Selection

This section highlights how to select the inductor suitable for the application requirements in terms of switching frequency, LED current accuracy and temperature.

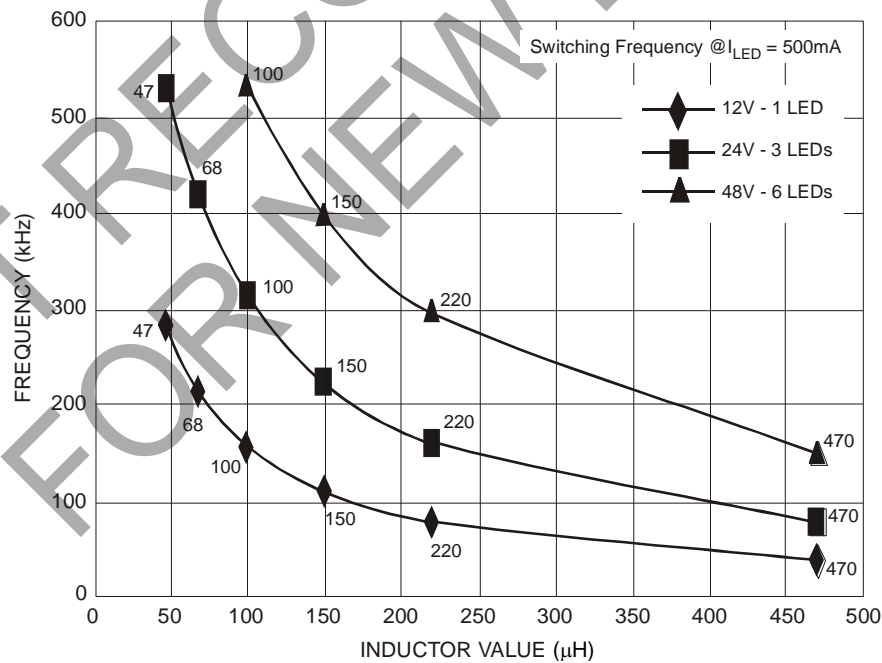

Figure. 15 Switching Frequency vs. Inductor Value

Application Information (Cont.)

The inductor influences the LED current accuracy that the system is able to provide. The following section highlights how to select the inductor in relation to the device packages and the LED current, while maintaining the chip temperature below +70°C.

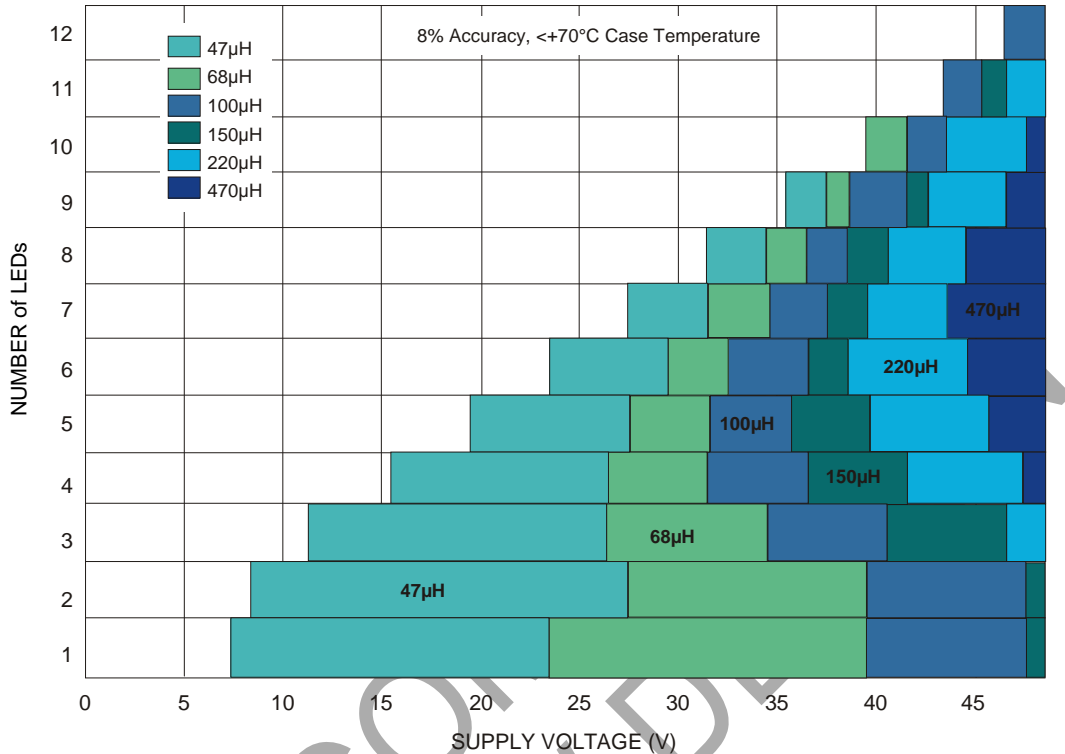

Figure. 16 Minimum Recommended Inductor with 500mA LED Current

Capacitor Selection

The small size of ceramic capacitors makes them ideal for AP8801 applications. X5R and X7R types are recommended because they retain their capacitance over wider voltage and temperature ranges than other types such as Z5U. A 2.2µF input capacitor is sufficient for most intended applications of AP8801.

A 4.7µF input capacitor is suggested for application with an input voltage equal or higher than 40V.

Diode Selection

Schottky diodes, e.g. B1100, with their low forward voltage drop and fast reverse recovery, are the ideal choice for AP8801 applications.

NOT RECOMMENDED FOR NEW DESIGN

Application Information (Cont.)

LED Current Adjustment/Dimming.

The LED current for the AP8801 can be adjusted by driving the CTRL with a digital signal (PWM dimming) or by driving the CTRL with a dc voltage between 0.3V and 2.5V (DC dimming).

If the CTRL pin is driven by an external voltage (lower than 2.5V), the average LED current is:

$$I_{LED} = \frac{V_{CTRL}}{V_{REF}} \times \frac{V_{THD}}{R_{SET}} \quad \text{where } V_{REF} \text{ is nominally } 1.25V$$

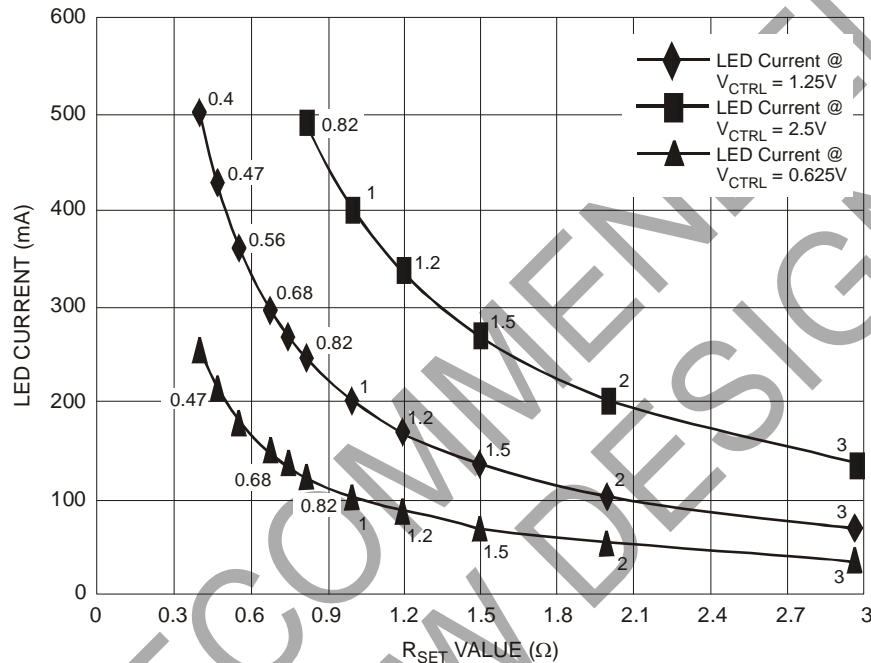

Figure 17 LED Current vs. R_{SET} and V_{CTRL}

Figure 17 shows that reducing the CTRL voltage by a factor of 2 also reduces the LED current by a factor of 2. The AP8801 has the ability vary the LED current by a factor of 2 above the default value set by RSET down to a factor of 0.24 of the nominal LED current. This provides an 8.33:1 dynamic range of the dc dimming.

A low pass filter on the CTRL pin of the AP8801 automatically provides some soft-start function of the LED current on initial start-up (this phenomenon can be seen in figure 7); the built in soft-start period can be increased by the addition of an external capacitor onto the CTRL pin.

The AP8801's dimming range can be increased above this dc dimming factor by applying a PWM signal to the CTRL pin using this method dimming dynamic ranges above 100 can be achieved.

Application Information (Cont.) (@ $T_A = +25^\circ\text{C}$, $V_{IN} = 12\text{V}$, unless otherwise specified.)

PWM Dimming of LED Current

When a low frequency PWM signal with voltages between 2.5V and a low level of zero is applied to the CTRL pin the output current will be switched on and off at the PWM frequency. The resultant LED current I_{LEDavg} will be proportional to the PWM duty cycle. See figure 18.

A Pulse Width Modulated (PWM) signal with a max resolution of 8-bit, can be applied to the CTRL pin to change the output current to a value above or below the nominal average value set by resistor R_{SET} .

To achieve this resolution the PWM frequency has to be lower than 500Hz. The ultimate resolution will be determined by the number of switching cycles required to get back to nominal LED current once the PWM voltage is high relative to PWM frequency. Lower switching frequencies and higher PWM frequencies will result in lower PWM dimming dynamic ranges.

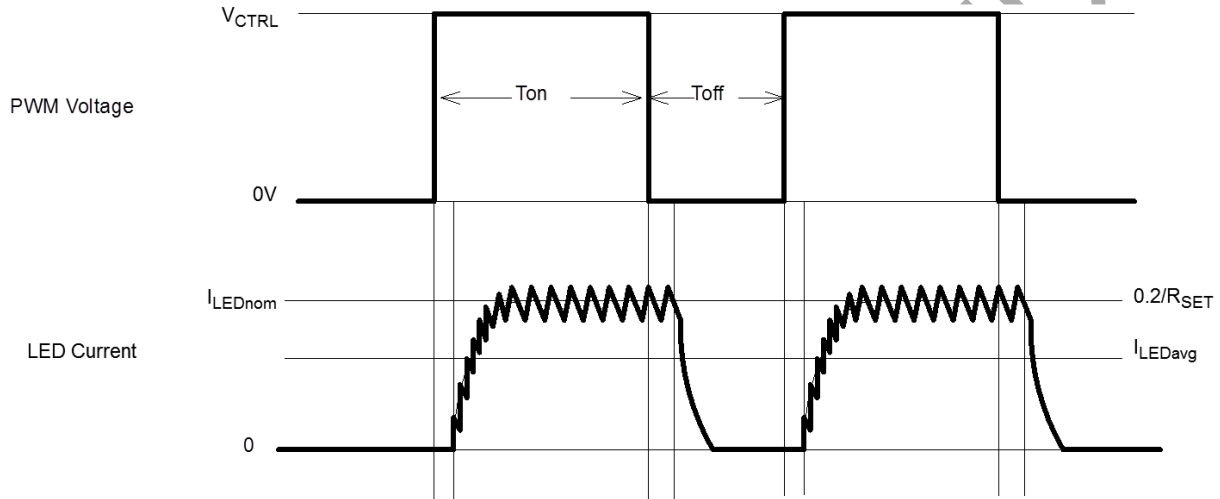

Figure 18 Low Frequency PWM Operating Waveforms

There are different ways of accomplishing PWM dimming of the AP8801 LED current:

Directly Driving CTRL Input

A Pulse Width Modulated (PWM) signal with duty cycle $DPWM$ can be applied to the CTRL pin to adjust the output current to a value above or below the nominal average value set by resistor R_{SET} . When driving the CTRL with a voltage waveform care should be taken not to exceed a drive voltage of 2.5V (where extra brightness is required) or 1.25V if a maximum of 100% brightness is required.

A way of avoiding over-driving the CTRL pin is use an open collector/drain driver to drive the CTRL pin.

Driving the CTRL Input via Open Collector Transistor

The recommended method of driving the CTRL pin and controlling the amplitude of the PWM waveform is to use a small NPN switching transistor. This uses the internal pull-up resistor between the CTRL pin and the internal voltage reference to pull-up CTRL pin when the external transistor is turned off.

Driving the CTRL Input from a Microcontroller

If the CTRL pin is driven by a MOSFET (either discrete or open-drain output of a micro-controller) then Schottky diode maybe be required due to high Gate / Drain capacitance, which could inject a negative spike into CTRL input of the AP8801 and cause erratic operation but the addition of a Schottky clamp diode (eg. Diodes Inc. SD103CWS) to ground and inclusion of a series resistor (3.3k) will prevent this.

Application Information (Cont.) (@ $T_A = +25^\circ\text{C}$, $V_{IN} = 12\text{V}$, unless otherwise specified.)

Soft-Start

An external capacitor from the CTRL pin to ground will provide a soft-start delay, by increasing the time taken for the voltage on this pin to rise to the turn-on threshold and by slowing down the rate of rise of the control voltage at the input of the comparator. Adding capacitance increases this delay by approximately $200\mu\text{s/nF}$. The graph below shows the variation of soft-start time for different values of capacitor.

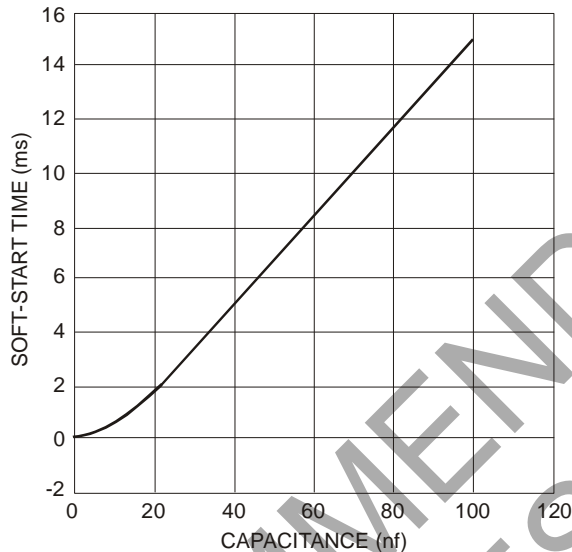

Figure. 19 Soft-Start Time vs. Capacitance from ADJ Pin to Ground

Thermal Considerations

The graph below in figure 20, gives details for power derating. This assumes the device to be on a FR-4 PCB, 2"x2", 2oz copper, minimum recommended pad layout on top layer and thermal vias to bottom layer ground plane standing in still air.

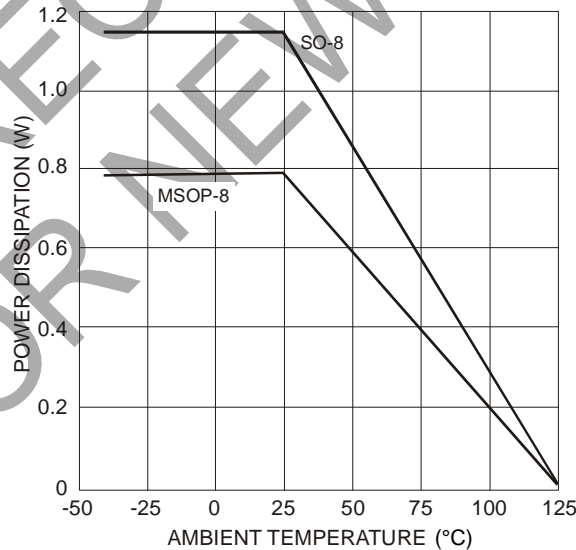

Figure. 20 Maximum Power Dissipation

Application Information (Cont.)

Package Selection

The device comes with a wide selection of packages. The suggested package is able to provide a case temperature below +70°C (with an ambient temperature of +25°C) for the combination of input voltage and load requested.

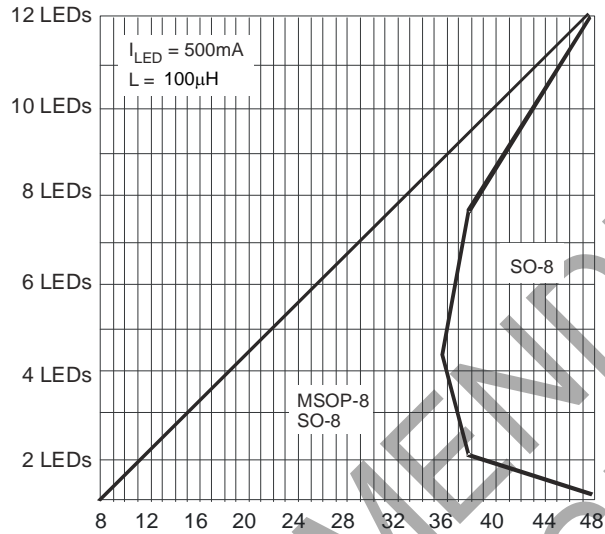

Figure 21 Package Section

Fault Condition Operation

The AP8801 has by default open LED protection. If the LEDs should become open circuit the AP8801 will stop oscillating; the SET pin will rise to V_{IN} and the SW pin will then fall to GND. No excessive voltages will be seen by the AP8801.

If the LEDs should become shorted together the AP8802H will continue to switch however the duty cycle at which it will operate will change dramatically and the switching frequency will most likely decrease. The on-time of the internal power MOSFET switch will be significantly reduced because almost all of the input voltage is now developed across the inductor. The off-time will be significantly increased because the reverse voltage across the inductor is now just the Schottky diode voltage (See Figure 20) causing a much slower decay in inductor current. During this condition the inductor current will remain within its controlled levels and so no excessive heat will be generated within the AP8801.

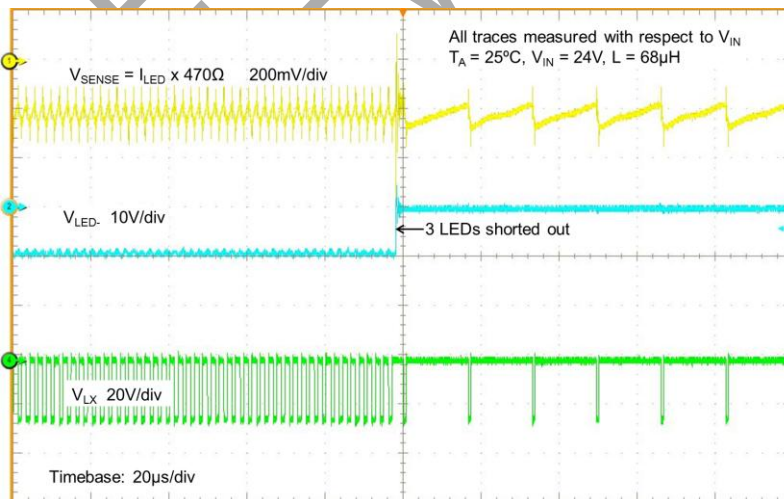
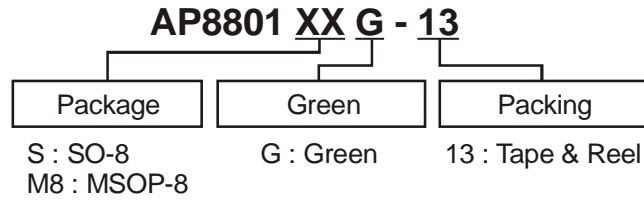

Figure 22 Switching Characteristics (normal open to short LED chain)

Ordering Information



Device	Package Code	Packaging (Note 9)	13" Tape and Reel	
			Quantity	Part Number Suffix
AP8801SG-13	S	SO-8	2500/Tape & Reel	-13
AP8801M8G-13	M8	MSOP-8	2500/Tape & Reel	-13

Note: 9. Pad layout as shown on Diodes Incorporated's suggested pad layout document, which can be found on our website at <http://www.diodes.com/package-outlines.html>.

Marking Information

(1) SO-8

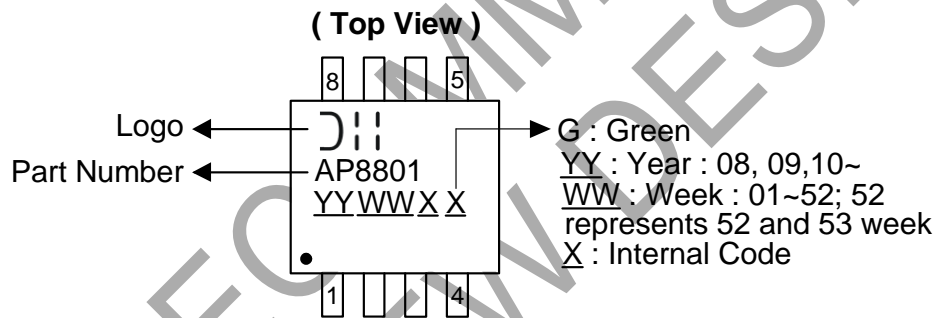

(2) MSOP-8

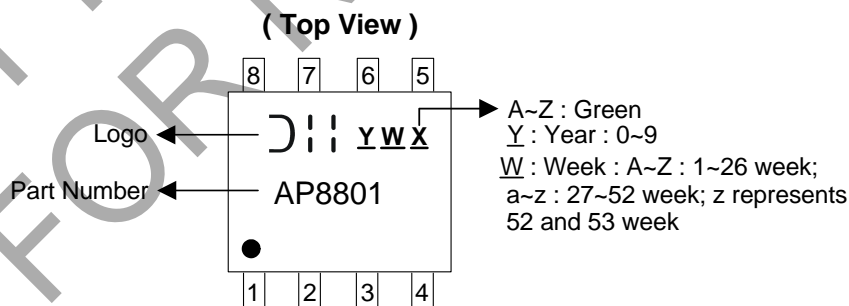

Package Outline Dimensions

Please see <http://www.diodes.com/package-outlines.html> for the latest version.

(1) SO-8

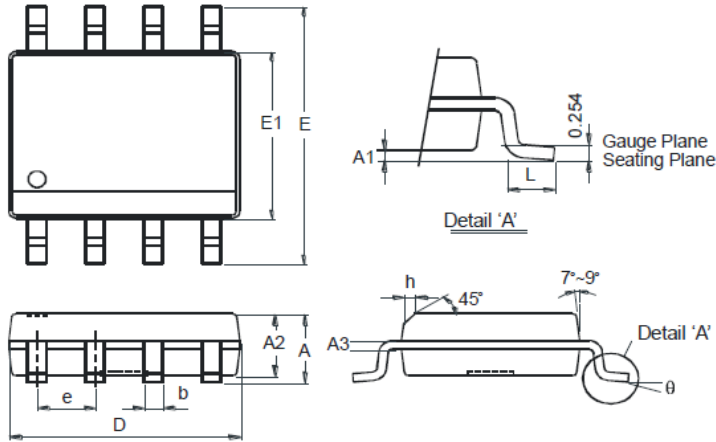

SO-8		
Dim	Min	Max
A	-	1.75
A1	0.10	0.20
A2	1.30	1.50
A3	0.15	0.25
b	0.3	0.5
D	4.85	4.95
E	5.90	6.10
E1	3.85	3.95
e	1.27 Typ	
h	-	0.35
L	0.62	0.82
θ	0°	8°
All Dimensions in mm		

(2) MSOP-8

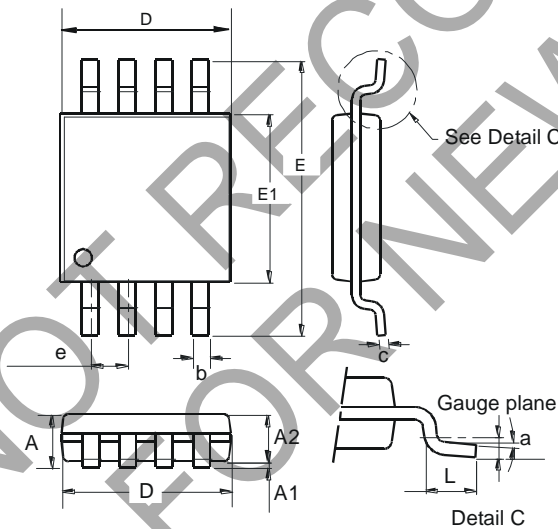

MSOP-8			
Dim	Min	Max	Typ
a	0°	6°	4°
A	—	1.10	—
A1	0.05	0.15	0.10
A2	0.75	0.95	0.86
b	0.22	0.38	0.30
c	0.08	0.23	0.15
D	2.90	3.05	3.00
e	—	—	0.65
E	4.80	5.00	4.90
E1	2.90	3.00	3.10
L	0.40	0.80	0.60
All Dimensions in mm			

IMPORTANT NOTICE

DIODES INCORPORATED MAKES NO WARRANTY OF ANY KIND, EXPRESS OR IMPLIED, WITH REGARDS TO THIS DOCUMENT, INCLUDING, BUT NOT LIMITED TO, THE IMPLIED WARRANTIES OF MERCHANTABILITY AND FITNESS FOR A PARTICULAR PURPOSE (AND THEIR EQUIVALENTS UNDER THE LAWS OF ANY JURISDICTION).

Diodes Incorporated and its subsidiaries reserve the right to make modifications, enhancements, improvements, corrections or other changes without further notice to this document and any product described herein. Diodes Incorporated does not assume any liability arising out of the application or use of this document or any product described herein; neither does Diodes Incorporated convey any license under its patent or trademark rights, nor the rights of others. Any Customer or user of this document or products described herein in such applications shall assume all risks of such use and will agree to hold Diodes Incorporated and all the companies whose products are represented on Diodes Incorporated website, harmless against all damages.

Diodes Incorporated does not warrant or accept any liability whatsoever in respect of any products purchased through unauthorized sales channel. Should Customers purchase or use Diodes Incorporated products for any unintended or unauthorized application, Customers shall indemnify and hold Diodes Incorporated and its representatives harmless against all claims, damages, expenses, and attorney fees arising out of, directly or indirectly, any claim of personal injury or death associated with such unintended or unauthorized application.

Products described herein may be covered by one or more United States, international or foreign patents pending. Product names and markings noted herein may also be covered by one or more United States, international or foreign trademarks.

This document is written in English but may be translated into multiple languages for reference. Only the English version of this document is the final and determinative format released by Diodes Incorporated.

LIFE SUPPORT

Diodes Incorporated products are specifically not authorized for use as critical components in life support devices or systems without the express written approval of the Chief Executive Officer of Diodes Incorporated. As used herein:

A. Life support devices or systems are devices or systems which:

1. are intended to implant into the body, or
2. support or sustain life and whose failure to perform when properly used in accordance with instructions for use provided in the labeling can be reasonably expected to result in significant injury to the user.

B. A critical component is any component in a life support device or system whose failure to perform can be reasonably expected to cause the failure of the life support device or to affect its safety or effectiveness.

Customers represent that they have all necessary expertise in the safety and regulatory ramifications of their life support devices or systems, and acknowledge and agree that they are solely responsible for all legal, regulatory and safety-related requirements concerning their products and any use of Diodes Incorporated products in such safety-critical, life support devices or systems, notwithstanding any devices- or systems-related information or support that may be provided by Diodes Incorporated. Further, Customers must fully indemnify Diodes Incorporated and its representatives against any damages arising out of the use of Diodes Incorporated products in such safety-critical, life support devices or systems.

Copyright © 2018, Diodes Incorporated

www.diodes.com