

mikromedia workStation^{v7}

for PIC[®], dsPIC33[®], PIC24[®] and PIC32[®]

We present you with a complete color schematics for mikromedia workStation v7 for PIC[®], dsPIC33[®], PIC24[®] and PIC32[®]. We wanted to make electronics understandable even for absolute beginners, so we made sure to make schematics clear and well organized, so you can get to know what your board is consisted of.

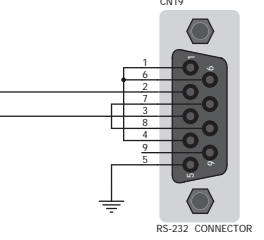

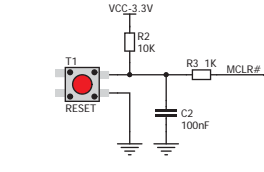
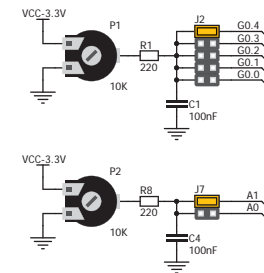
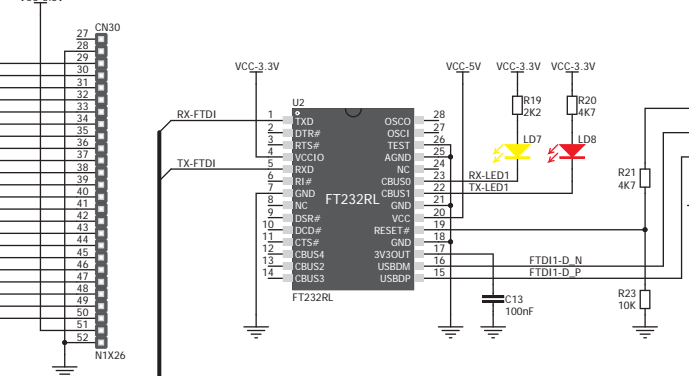
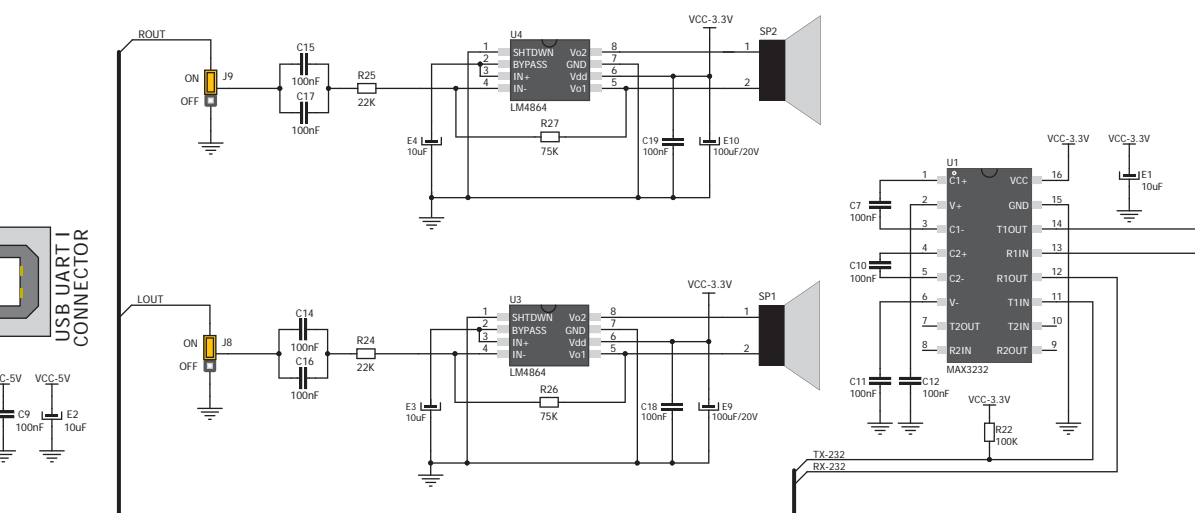
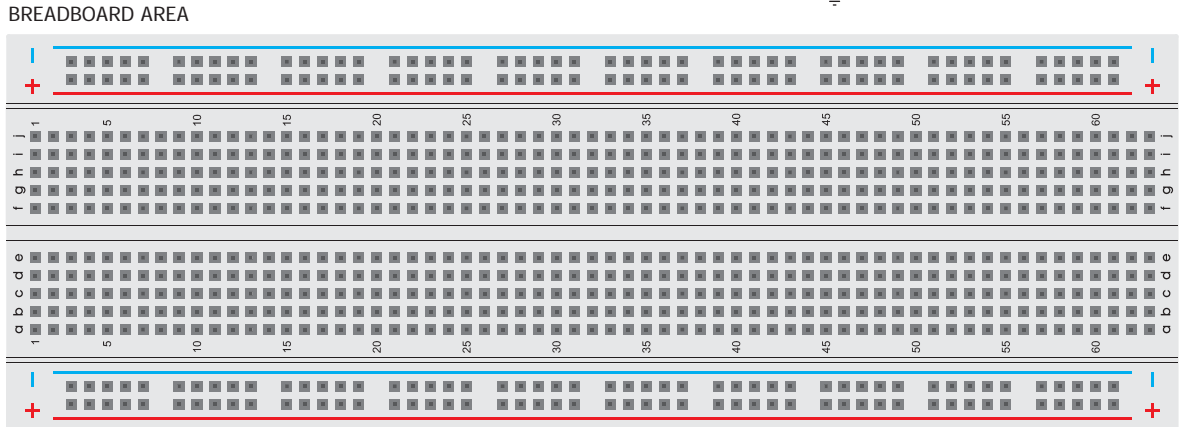
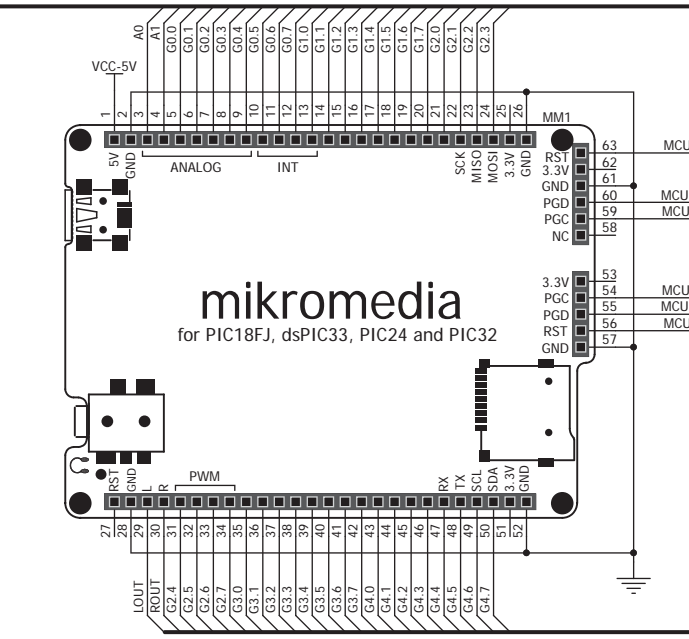
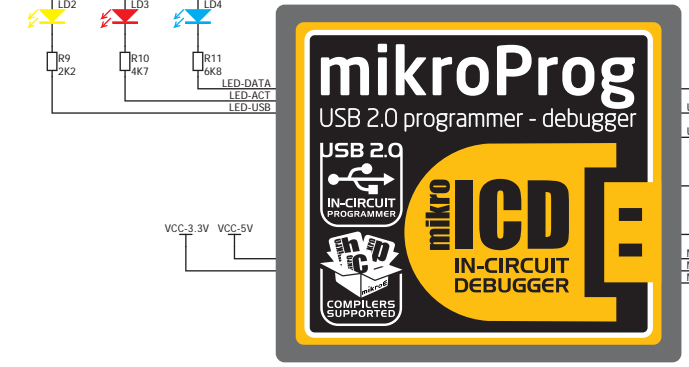
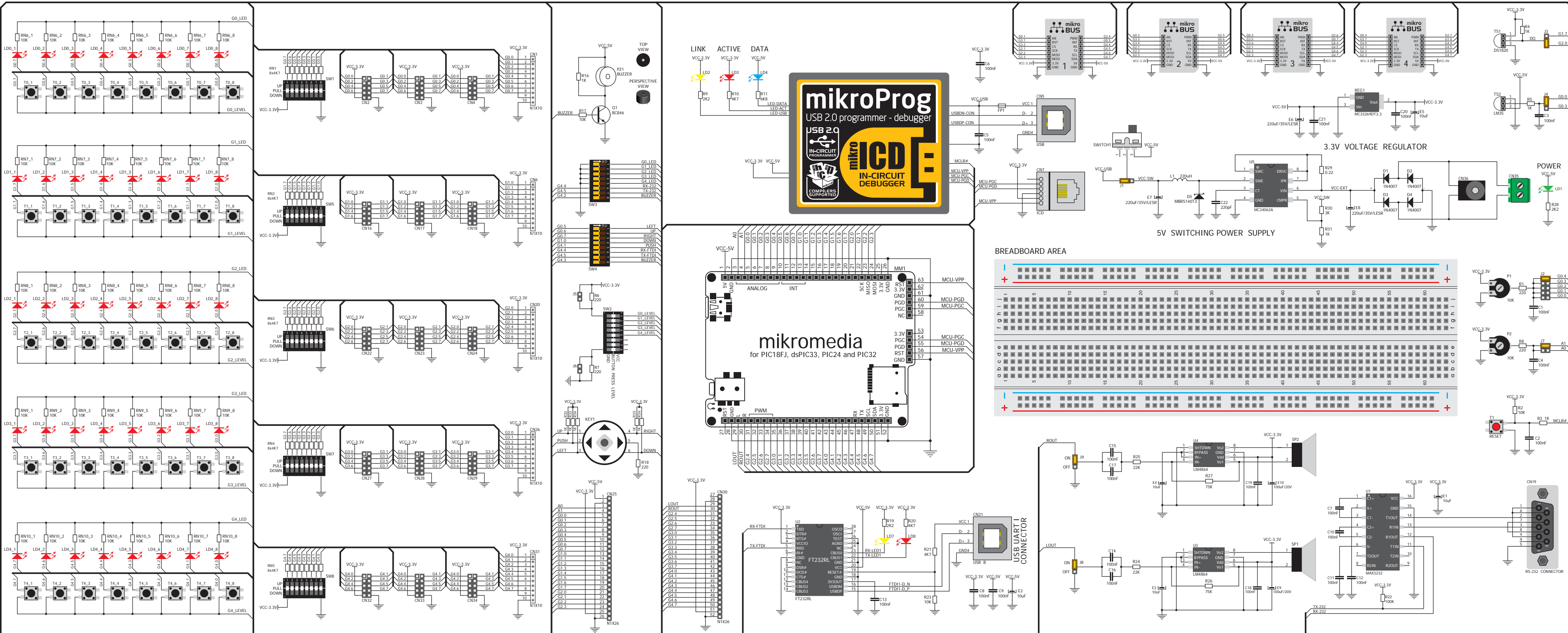
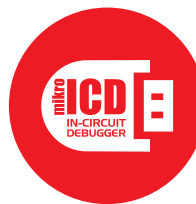

mikromedia workStation v7 for PIC®
Schematics ver. 1.00



Designed by
MikroElektronika Ltd.
www.mikroe.com
June 2012.