

Messrs.					
Product Specification	Model:	AWG-F32240KFWHSGWT-CT	Rev. No.	Issued Date.	Page.
			A	2008/11/20	1 / 1

LIQUID CRYSTAL DISPLAY MODULE
MODEL: AWG-F32240KFWHSGWT-CT
Customer's No.:



Acceptance

,

,

,

Approved and Checked by

Approved by	Checked by		Made by
			

RECORD OF REVISION

Revision Date	Page	Contents	Editor
2008/11/20	-	New Release	Edward

1 FEATURES

- (1) Display format : 320 × 240 dot-matrix, 1/240 duty.
- (2) Construction : FSTN LCD, TAB type LCD driver, White Edge LED backlight, Touch Panel , Touch Panel controller (TSC2046) and PCB.
- (3) Display type : FSTN ,Transflective , 6 o'clock view.
- (4) Controller : RA8835AP3N.
- (5) Common and Segment Driver : IST3031 and IST3032.
- (6) **New Driving Method** CMOS LCD Driver for Low Power Consumption Driving.
- (7) 5V or 3.3V single power input. Built-in specific power supplies circuit for LCD driving. **Ultra Low Power Consumption.**
- (8) Normal temperature type.
- (9) Portrait(Default) or Landscape Display Type Selectable by Jumper Setting.
- (10) 80 or 68 Family MPU Selectable by Jumper Setting
- (11) ROHS compliant.

2 MECHANICAL DATA

Parameter	Stand Value	Unit
Dot size	0.225(W) × 0.225(H)	mm
Dot pitch	0.24(W) × 0.24(H)	mm
Viewing area	81.8 (W) × 62.0 (H)	mm
Module size	92.2(W) × 73.0(H) × 6.4 max (T)	mm
Module size (w/ Touch panel)	92.2(W) × 73.0(H) × 7.8 max (T)	mm

3 ABSOLUTE MAXIMUM RATINGS

Parameter		Symbol	Min	Max	Unit
Logic Circuit Supply Voltage		VDD-VSS	-0.3	7.0	V
LCD Driving Voltage		--	-0.3	26.0	V
Input Voltage		VI	-0.3	VDD+0.3	V
Normal temp. type	Operating Temp.	TOP	0	50	°C
	Storage Temp.	TSTG	-20	70	°C

4 ELECTRO-OPTICAL CHARACTERISTICS

Parameter	Symbol	Condition	Min	Typ	Max	Unit	Note
----- Electronic Characteristics -----							
Logic Circuit Supply Voltage	VDD-VSS	--	2.6	3.3	5.5	V	
LCD Driving Voltage	--	0 °C	20.4	21.5	22.6	V	0 ~ 50 °C for Normal Temp. type
		25 °C	19.4	20.4	21.4		
		50 °C	19.2	20.2	21.2		
Input Voltage	VIH	--	0.7 VDD	--	VDD	V	
	VIL	--	VSS	--	0.2 VDD	V	
Logic Supply Current	ICC	VCC = 3.3V	--	20	--	mA	
----- Optical Characteristics -----							
Contrast	CR	FSTN type		5			Note 1
Rise Time	tr	25°C	--	190	285	ms	Note 2
Fall Time	tf	25°C	--	350	525	ms	
Viewing Angle Range	θ f	25°C & CR≥2	35	--	--	Deg.	Note 3
	θ b		25	--	--		
	θ l		40	--	--		
	θ r		30	--	--		
Frame Frequency	fF	25°C	--	70	--	Hz	
----- White LED Back-light Characteristics -----							
Parameter	Symbol	Condition	Min	Typ	Max	Unit	Note
Forward Current	IF	--	--	60	80	mA	NOTE 4
LCM Luminous intensity		VF=3.2V	--	10	--	cd/m ²	NOTE 4
Forward Voltage	VF	IF=60mA	--	3.2	3.5	V	NOTE 5
LED C.I.E	X	IF=60mA	0.26	0.30	0.34		NOTE 6
	Y	IF=60mA	0.27	0.31	0.35		

(NOTE 4): Luminous intensity is decided by forward current of White LED.

(NOTE 5): White LEDs are with voltage tolerance

(NOTE 6): White LEDs are with color tolerance

* LED Dice number = 4

Please keep the IF between 60~80mA

Luminous intensity is decided by IF

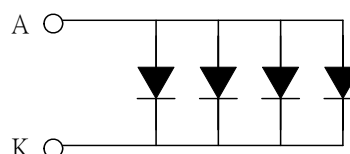

(NOTE 1) Contrast ratio :

$$CR = (\text{Brightness in OFF state}) / (\text{Brightness in ON state})$$

(NOTE 2) Response time :

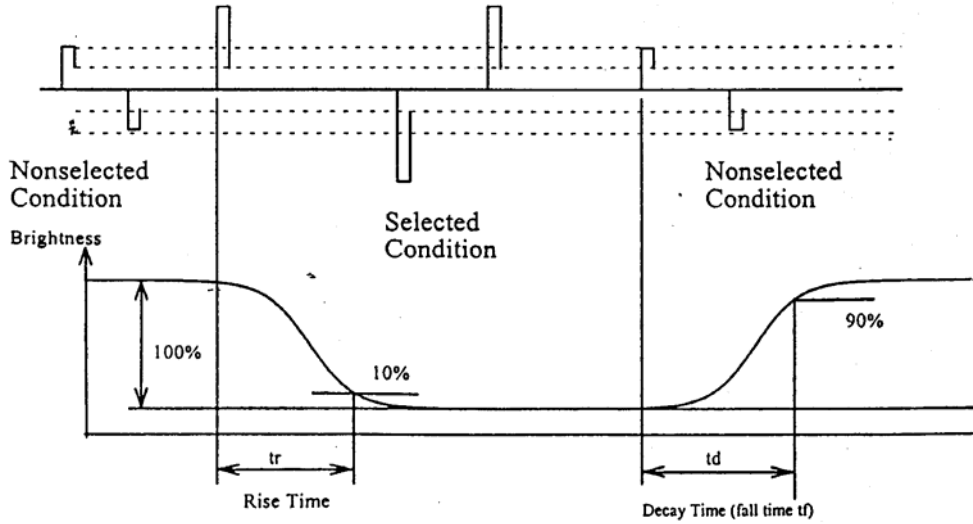

(NOTE 3) Viewing angle

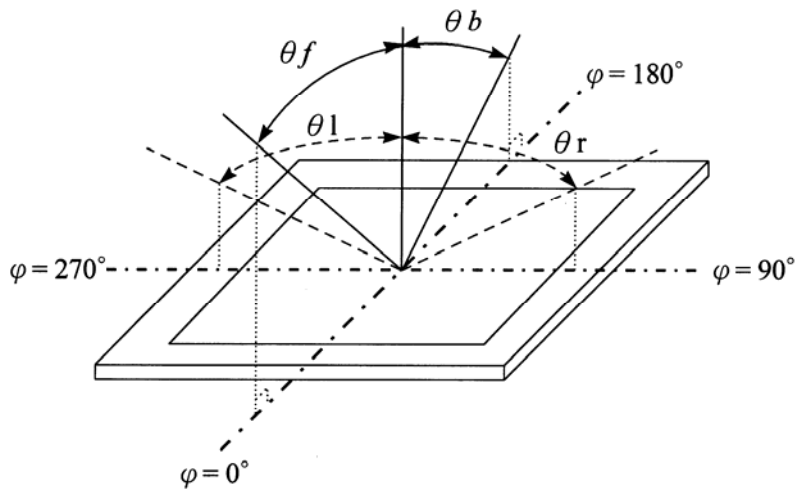

(NOTE 7) ONE LED

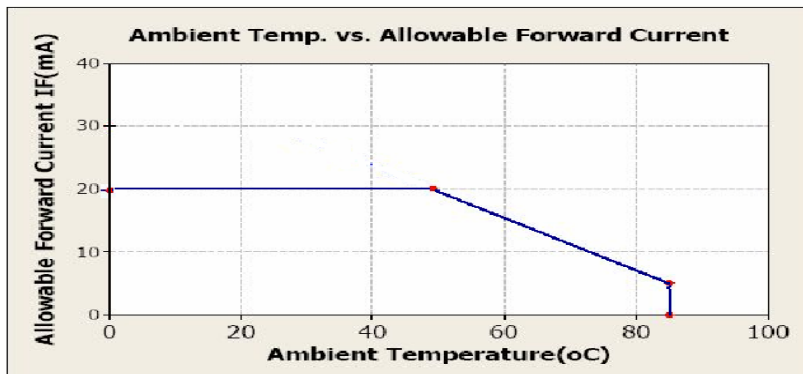

Touch Panel Electrical Specification

Parameter	Specification	Condition
ON Resistance	200 Ω ~ 640 Ω	X Axis
	350 Ω ~ 1040 Ω	Y Axis
Insulating Resistance	More than 20M Ω	DC 25 V
Chattering	Less Than 15 ms	100K Ω Pull-Up

5 BLOCK DIAGRAM

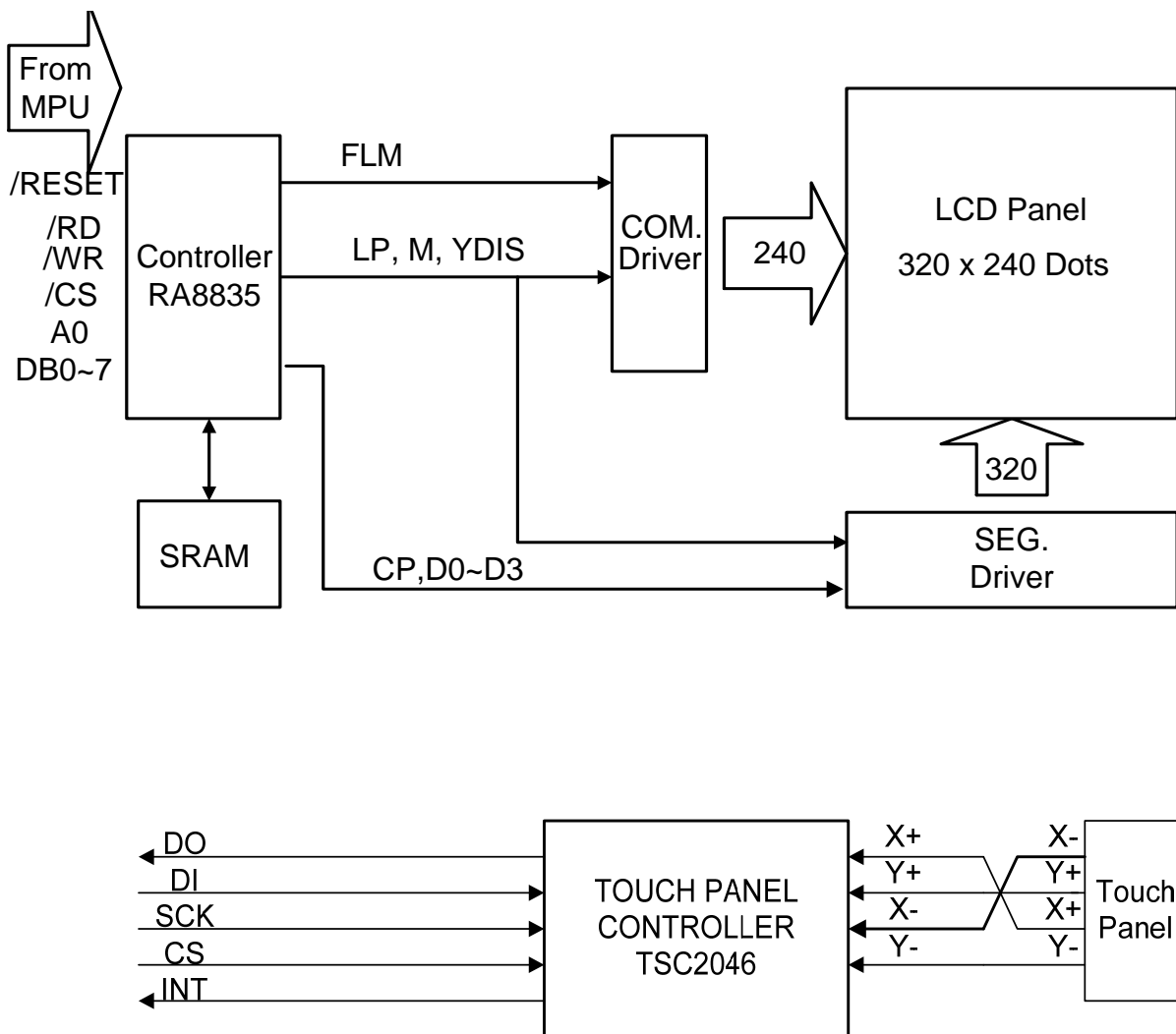

* Please use the YDIS pin and the inner command of the RA8835A to control Display On/Off.

Power Supply Example

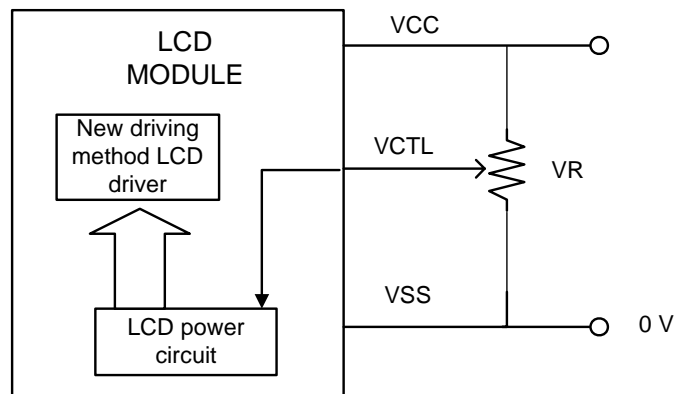

Note: VR = 20 K, VCTL is about 0.4V

6 INTERFACE DEFINITION

PIN NO.	SIGNAL	LEVEL	FUNCTION
1	/RESET	H/L	Reset Signal
2	/RD	H/L	80 Series: Read Signal 68 Series: Enable Signal(E)
3	/WR	H/L	80 Series: Write Signal 68 Series: R/W Signal
4	/CS	H/L	Chip Select Signal
5	A0	H/L	Data Type Selection
6 ~ 13	DB0~DB7	H/L	Data Input(8 bits)
14	VDD	-	Power Supply for Logic(+3.3V)
15	VSS	-	Power Supply(Ground : 0V)
16	VCTL	-	Contrast Adjustment Input
17	NC	-	No Connection
18*	SK / X1	-	Serial Clock Touch Panel Left Signal in X Axis
19*	DO / X2	-	Serial Data Output Touch Panel Right Signal in X Axis
20*	DI / Y1	-	Serial Data Input Touch Panel Upper Signal in Y Axis
21*	CS / Y2	-	T/P controller Chip Select. Active Low Touch Panel Lower Signal in X Axis
22*	INT	-	Pen Interrupt
23	A	-	LED Anode
24	K	-	LED Cathode

* 18~22 : SK, DO, DI, CS, INT for Touch Panel controller AD7843

/ X1, X2, Y1, Y2 for Touch Panel (without AD7843)

7 TIMING CHARACTERISTICS

7.1 8080 Family Interface Timing

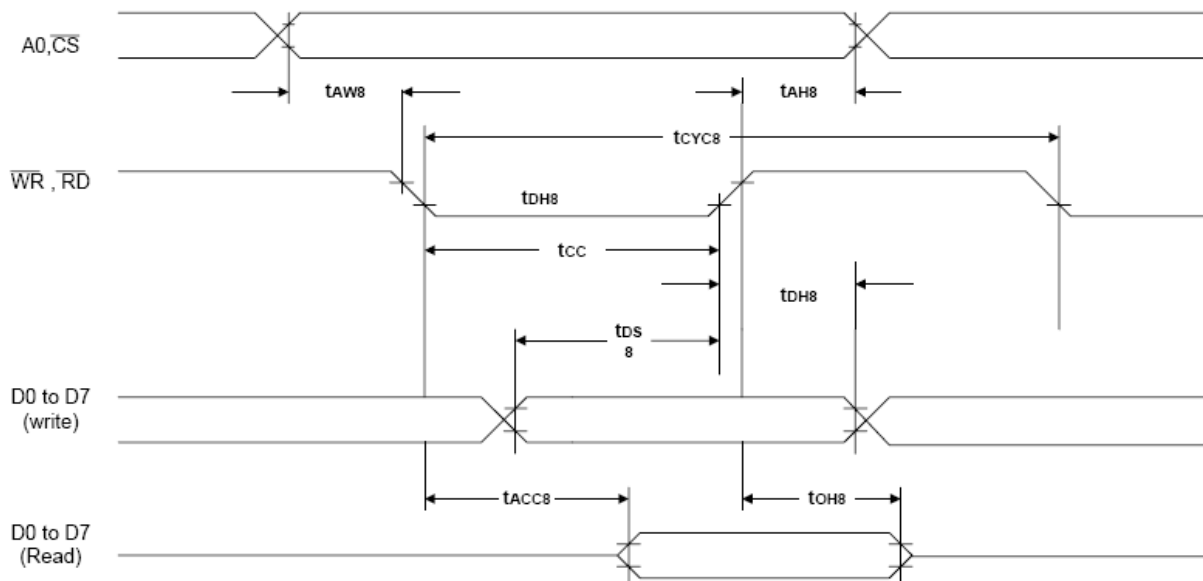

$T_a = -20$ to 75°C

Signal	Symbol	Parameter	$V_{DD} = 4.5$ to 5.5V		$V_{DD} = 2.7$ to 4.5V		Unit	Condition
			Min.	Max.	Min.	Max.		
A0, $\overline{\text{CS}}$	t_{AH8}	Address hold time	10	—	10	—	ns	CL = 100pF
	t_{AW8}	Address setup time	0	—	0	—	ns	
$\overline{\text{WR}}$, $\overline{\text{RD}}$	t_{CYC8}	System cycle time	note.	—	note.	—	ns	
	t_{CC}	Strobe pulse width	120	—	150	—	ns	
D0 to D7	t_{DS8}	Data setup time	120	—	120	—	ns	
	t_{DH8}	Data hold time	5	—	5	—	ns	
	t_{ACC8}	$\overline{\text{RD}}$ access time	—	50	—	80	ns	
	t_{OH8}	Output disable time	10	50	10	55	ns	

Note: For memory control and system control commands:

$$t_{CYC8} = 2t_C + t_{CC} + t_{CEA} + 75 > t_{ACV} + 245$$

For all other commands:

$$t_{CYC8} = 4t_C + t_{CC} + 30$$

7.2 6800 Family Interface Timing

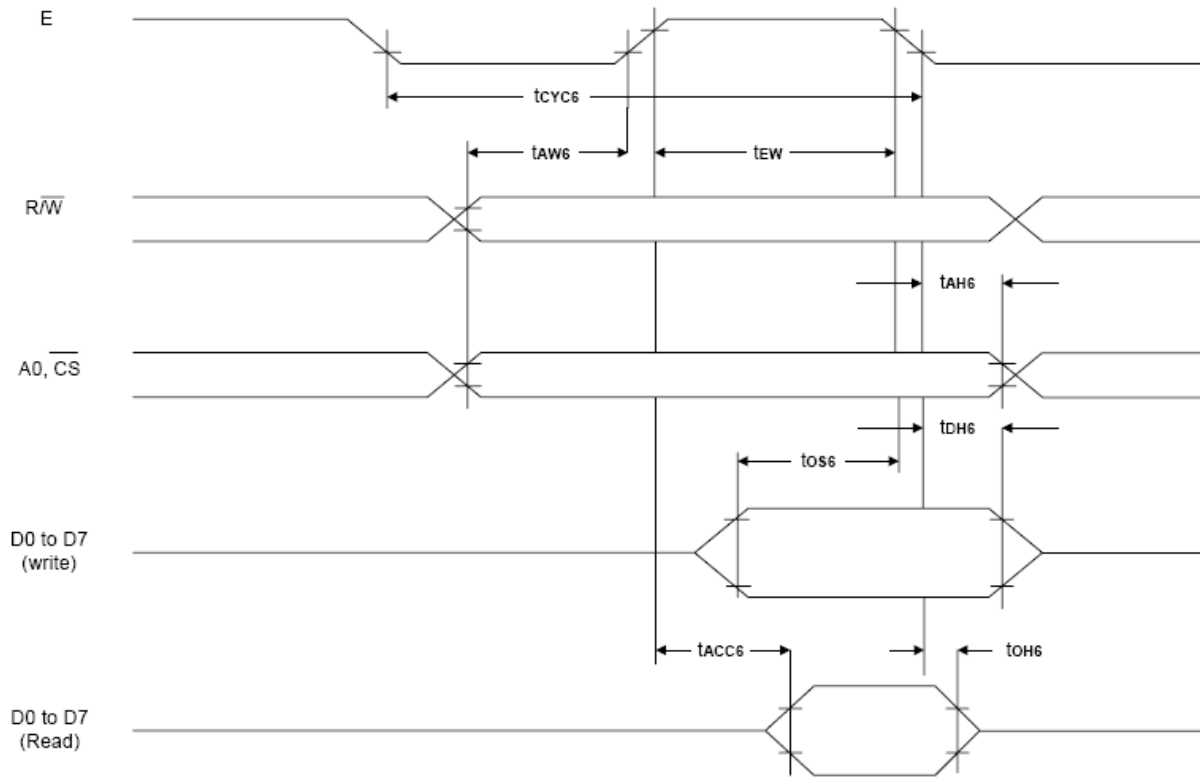

$T_a = -20$ to 75°C

Signal	Symbol	Parameter	$V_{DD} = 4.5$ to 5.5V		$V_{DD} = 2.7$ to 4.5V		Unit	Condition
			Min.	Max.	Min.	Max.		
A0, $\overline{\text{CS}}$, R/($\overline{\text{W}}$)	t_{CYC6}	System cycle time	note.	—	note.	—	ns	CL = 100 pF
	t_{AW6}	Address setup time	0	—	10	—	ns	
	t_{AH6}	Address hold time	0	—	0	—	ns	
D0 to D7	t_{DS6}	Data setup time	100	—	120	—	ns	
	t_{DH6}	Data hold time	0	—	0	—	ns	
	t_{OH6}	Output disable time	10	50	10	75	ns	
	t_{ACC6}	Access time	—	85	—	130	ns	
E	t_{EW}	Enable pulse width	120	—	150	—	ns	

Note: For memory control and system control commands:

$$t_{CYC6} = 2t_C + t_{EW} + t_{CEA} + 75 > t_{ACV} + 245$$

For all other commands:

$$t_{CYC6} = 4t_C + t_{EW} + 30$$

8 INSTRUCTION SET

Class	Command	Code											Hex	Command Description	Command read parameters	
		/RD	/WR	A0	D7	D6	D5	D4	D3	D2	D1	D0			Number of bytes	Section
System Control	SYSTEM SET	1	0	1	0	1	0	0	0	0	0	0	40	Initialized Device and display	8	8.2.1
	SLEEP IN	1	0	1	0	1	0	1	0	0	1	1	53	Enter Standby mode	0	8.2.2
Display Control	DISP ON/OFF	1	0	1	0	1	0	1	1	0	0	D	58, 59	Enable and disable display and display flashing	1	8.3.1
	SCROLL	1	0	1	0	1	0	0	0	1	0	0	44	set Display start address and display regions	10	8.3.2
	CSRFORM	1	0	1	0	1	0	1	1	1	0	1	5D	Set cursor byte	2	8.3.3
	CGRAM ADDR.	1	0	1	0	1	0	1	1	1	0	0	5C	Set start address of character generator RAM	2	8.3.6
	CSRDIR	1	0	1	0	1	0	0	1	1	CD 1	CD 0	4C to 4F	Set direction of cursor movement	0	8.3.4
	HDOT SCR	1	0	1	0	1	0	1	1		1	0	5A	set horizontal scroll position	1	8.3.7
	OVLAY	1	0	1	0	1	0	1	1	0	1	1	5B	set display overlay format	1	8.3.5
Drawing Control	CSRW	1	0	1	0	1	0	0	0	1	1	0	46	set cursor address	2	8.4.1
	CSRR	1	0	1	0	1	0	0	0	1	1	1	47	read cursor address	2	8.4.2
Memory Control	MWRITE	1	0	1	0	1	0	0	0	0	1	0	42	write to display memory	-	8.5.1
	MREAD	1	0	1	0	1	0	0	0	0	1	1	43	read from display memory	-	8.5.2

Note:

- In general, the internal registers of the RA8835A are modified as each command parameter is input. However, the microprocessor does not have to set all the parameters of a command and may send a new command before all parameters have been input. The internal registers for the parameters that have been input will have been changed but the remaining parameter registers are unchanged.
 - bytes parameters(where two bytes are treated as 1 data item) are handled as following:
 - CSRW, CSRR: Each byte is processed individually. The microprocessor may read or write just the low byte of the cursor address.
 - SYSTEM SET, SCROLL, CGRAM ADR. : Both parameter bytes are processed together. If the command is changed after half of the parameter has been input, the single byte is ignored.
 - APL and APH are 2-byte parameters, but are treated as two 1-byte parameters.
 - Please refer to RA8835A LCD Controller Data Book for detail.

9 INNER DATA FORMAT

		COM1								COM240									
#1	D3	D3	D3																D3
#2	D2	D2	D2																D2
	D1	D1	D1																D1
	D0	D0	D0																D0
	D3																		D3
	D2	D2																	D2
	D1	D1																	D1
#320	D0	D0																	D0

Portrait Display Type (Top View)

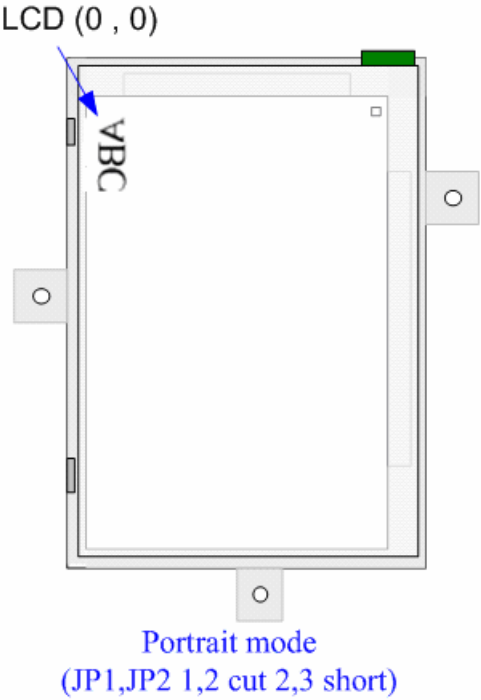

	SEG1										SEG320				
#1	D3	D2	D1	D0	D3	D2			-			D3	D2	D1	D0
#2	D3	D2	D1	D0	D3	D2						D3	D2	D1	D0
#240	D3	D2	D1	D0	D3	D2						D3	D2	D1	D0

Landscape Display Type(Top View)

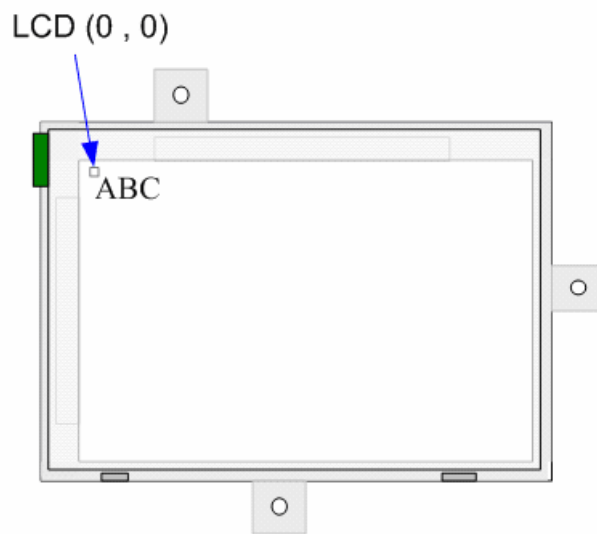

Land Scape mode
(JP1,JP2 1,2 cut 2,3 short)

* Regardless Portrait or Landscape type, both are 1/240 duty. The only difference is the opposite scan direction on Common driver. The character mode of RA8835A could only be used on Landscape type. The character will be Mirrored on Portrait type.

10 JUMPER SETTING

Item	Option	Jumper Setting	Remark
Display Type	Portrait (default)	Pin 1,2 short on JP1&JP2	
	Landscape	Pin 2,3 short on JP1&JP2	
MPU	80 family (default)	Pin 1,2 short on JP4	
	68 family	Pin 2,3 short on JP4	

11 QUALITY AND RELIABILITY

11.1 TEST CONDITIONS

Tests should be conducted under the following conditions :

Ambient temperature : $25 \pm 5^{\circ}\text{C}$

Humidity : $60 \pm 25\% \text{ RH}$.

11.2 SAMPLING PLAN

Sampling method shall be in accordance with MIL-STD-105E , level II, normal single sampling plan .

11.3 ACCEPTABLE QUALITY LEVEL

A major defect is defined as one that could cause failure to or materially reduce the usability of the unit for its intended purpose. A minor defect is one that does not materially reduce the usability of the unit for its intended purpose or is an infringement from established standards and has no significant bearing on its effective use or operation.

11.4 APPEARANCE

An appearance test should be conducted by human sight at approximately 30 cm distance from the LCD module under fluorescent light. The inspection area of LCD panel shall be within the range of following limits.

11.5 INSPECTION QUALITY CRITERIA

Item	Description of defects			Class of Defects	Acceptable level (%)	
Function	Short circuit or Pattern cut			Major	0.65	
Dimension	Deviation from drawings			Major	1.5	
Black spots	Ave . dia . D	area A	area B	Minor	2.5	
	$D \leq 0.2$	Disregard				
	$0.2 < D \leq 0.3$	3	4			
	$0.3 < D \leq 0.4$	2	3			
	$0.4 < D$	0	1			
Black lines	Width W, Length L		A	B	Minor	2.5
	$W \leq 0.03$		disregard			
	$0.03 < W \leq 0.05$		3	4		
	$0.05 < W \leq 0.07, L \leq 3.0$		1	1		
	See line criteria					
Bubbles in polarizer	Average diameter D $0.2 < D < 0.5$ mm for N = 4, D > 0.5 for N = 1			Minor	2.5	
Color uniformity	Rainbow color or newton ring.			Minor	2.5	
Glass Scratches	Obvious visible damage.			Minor	2.5	
Contrast ratio	See note 1			Minor	2.5	
Response time	See note 2			Minor	2.5	
Viewing angle	See note 3			Minor	2.5	

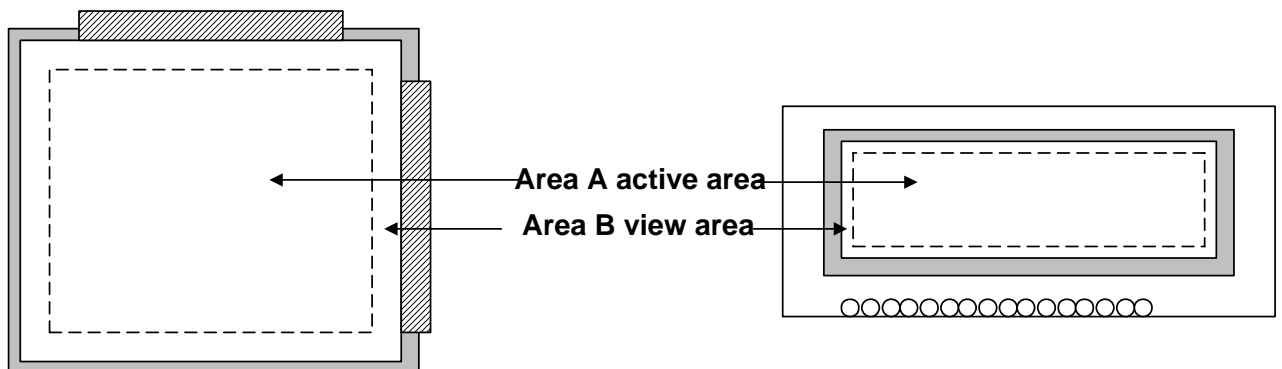

11.6 RELIABILITY

Test Item	Test Conditions		Note
	Normal Temp. type	Extended Temp. type	
High Temperature Operation	50±3°C , t=96 hrs	70±3°C , t=96 hrs	
Low Temperature Operation	0±3°C , t=96 hrs	-20±3°C , t=96 hrs	
High Temperature Storage	70±3°C , t=96 hrs	80±3°C , t=96 hrs	1,2
Low Temperature Storage	-20±3°C , t=96 hrs	-30±3°C , t=96 hrs	1,2
Thermal Shock Test	-20°C ~ 25°C ~ 70°C 30 m in. 5 min. 30 min. (1 cycle) Total 5 cycle	-30°C ~ 25°C ~ 80°C 30 min. 5 min. 30 min. (1 cycle) Total 5 cycle	1,2
Humidity Test	40 °C, Humidity 90%, 96 hrs		1,2
Vibration Test (Packing)	Sweep frequency : 10 ~ 55 ~ 10 Hz/1min Amplitude : 0.75mm Test direction : X.Y.Z/3 axis Duration : 30min/each axis		2

Note 1 : Condensation of water is not permitted on the module.

Note 2 : The module should be inspected after 1 hour storage in normal conditions
(15-35°C , 45-65%RH).

Definitions of life end point :

- Current drain should be smaller than the specific value.
- Function of the module should be maintained.
- Appearance and display quality should not have degraded noticeably.
- Contrast ratio should be greater than 50% of the initial value.

12 HANDLING PRECAUTIONS

- (1) A LCD module is a fragile item and should not be subjected to strong mechanical shocks.
- (2) Avoid applying pressure to the module surface. This will distort the glass and cause a change in color.
- (3) Under no circumstances should the position of the bezel tabs or their shape be modified.
- (4) Do not modify the display PCB in either shape or positioning of components.
- (5) Do not modify or move location of the zebra or heat seal connectors.
- (6) The device should only be soldered to during interfacing. Modification to other areas of the board should not be carried out.
- (7) In the event of LCD breakage and resultant leakage of fluid do not inhale, ingest or make contact with the skin. If contact is made rinse immediately.
- (8) When cleaning the module use a soft damp cloth with a mild solvent, such as Isopropyl or Ethyl alcohol. The use of water, ketone or aromatic is not permitted.
- (9) Prior to initial power up input signals should not be applied.
- (10) Protect the module against static electricity and observe appropriate anti-static precautions.

REV	DESCRIPTION	DRAWER	CHECKER	DATE

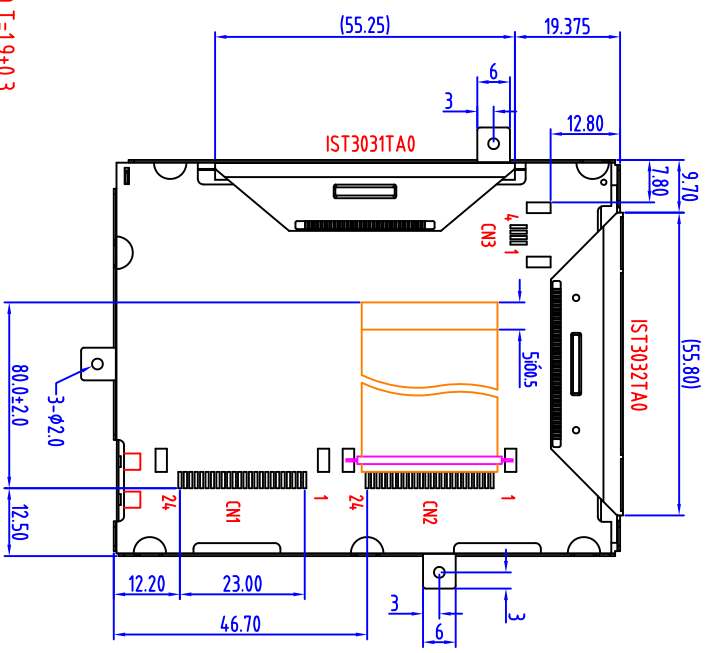
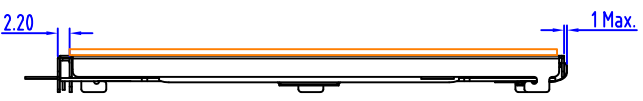
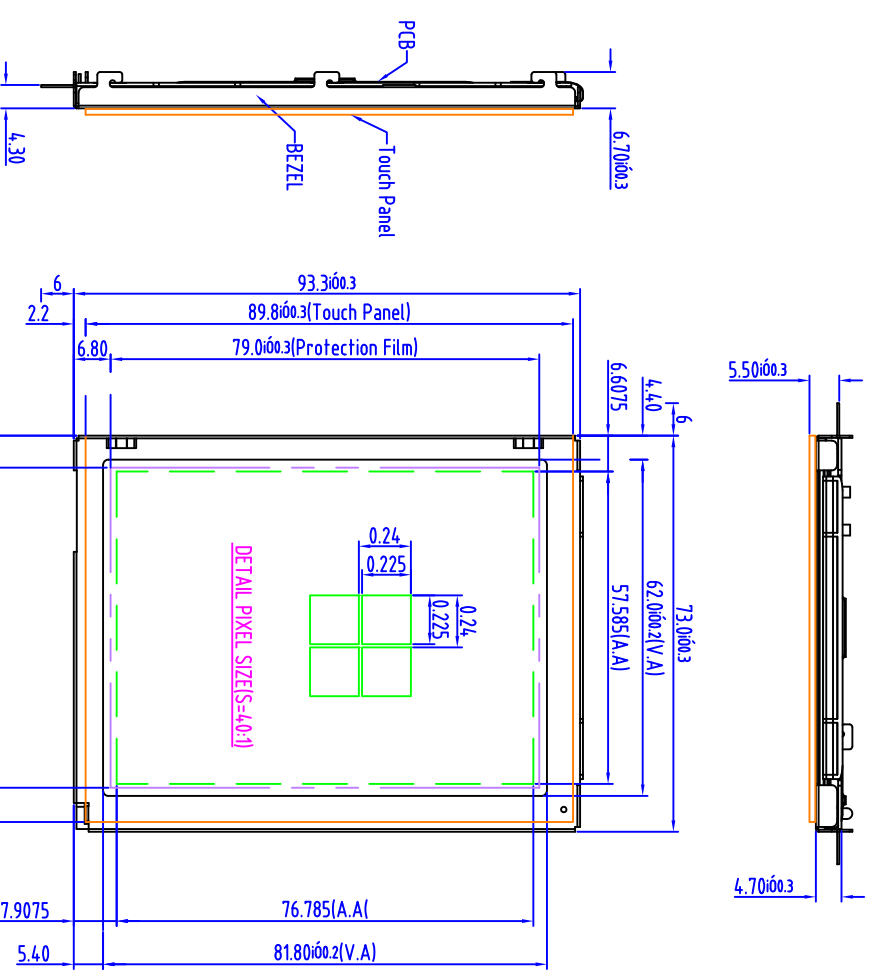

Note:
 LCD T=1.9±0.3
 Bezel T=0.4
 LED T=1.5Max.
 PCB T=0.6

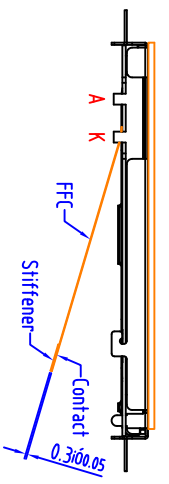

CN1 PIN ASSIGNMENT			
1	/RESET	13	DB7
2	/RD	14	VDD
3	/MR	15	VSS
4	/CS	16	VCTL
5	A0	17	NC
6	DB0	18	SK/X1
7	DB1	19	D0/X2
8	DB2	20	D1/Y1
9	DB3	21	CS/Y2
10	DB4	22	INT
11	DB5	23	LEDA
12	DB6	24	LEDK

TOLERANCE GRADE(%)	A	B
~6	0.05	0.1
6~18	0.08	0.18
18~50	0.1	0.25
50~180	0.2	0.4
180~	0.3	0.5

Recommend	Company	Parts No.
CN1	Molex.	52207-2490
	AMP.	2487951-4

Note:
 1. Unless indicated, Tolerance Grade "B" is adopted.

TITLE	LCD MODULE	UNIT:	mm	Product :	32240KB
DATE	2008.11.17	SCALE:	1/1	DRW NO.:	32240KB-01
		SHEET:	1/1	REV:	A
UNLESS OTHERWISE SPECIFIED TOLERANCE IS AS INDICATED IN THE DIMENSIONS. BEZEL'S ANGLES IS ±0.5°					