

Demo Manual DC366A

LTC3200 Constant Frequency Charge Pump

QUICK START GUIDE

DC366A is set up to easily evaluate the LTC3200 low noise charge pump. Refer to Figure 1 for equipment setup and follow the procedure outlined below.

- Before turning on the power supply connect a 3.3V, 500mA bench supply to the VIN and GND (E1 and E2) terminals as shown in Figure 1.
- Ensure that jumpers JP2 and JP3 are installed on the board. Set jumper JP1 in the "ON" position.
- Turn on the input supply and observe that the white LEDs light up. The VFB voltage should measure approximately 1.25V.
- When measuring the input/output voltage ripple care must be taken to avoid a long ground return for the oscilloscope probe. After removing the grabber and outer plastic sleeve from the scope probe, measure the input ripple by touching the probe between VIN and GND (E1 to E2). Measure the output ripple by touching the probe between VOUT and GND (E4 to E5) as shown in Figure 2.

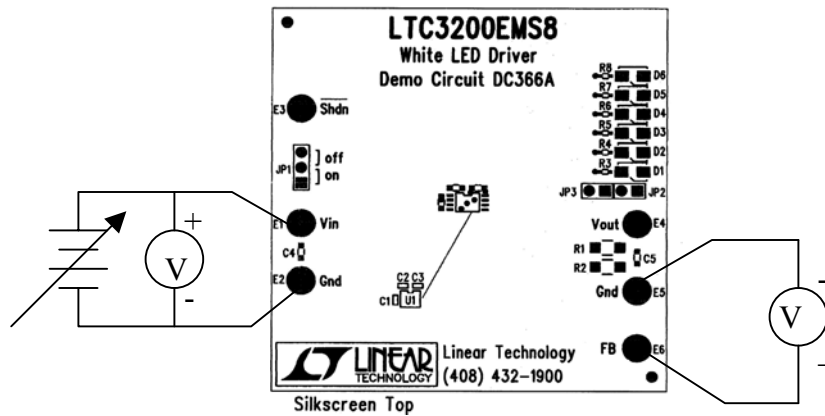

Figure 1 DC366A Test and Measurement Setup

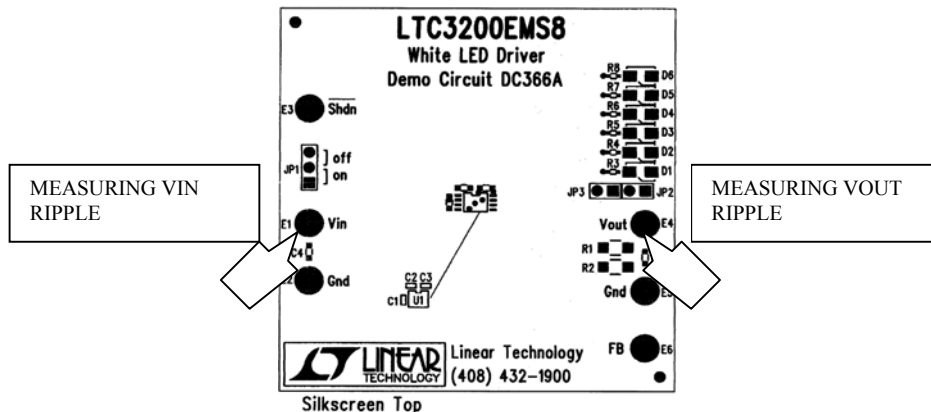

Figure 2 Proper Noise Measurement Technique